

The Development of Digital Technologies for  
Use in Jewellery with Medical Applications

LEON B. M. WILLIAMS

A thesis submitted in partial fulfilment of the  
requirements of the Royal College of Art for the  
degree of Doctor of Philosophy

**VOLUME I OF III**

April 2009

The Royal College of Art

## COPYRIGHT STATEMENT

“This text represents the submission for the degree of Doctor of Philosophy at the Royal College of Art. This copy has been supplied for the purpose of research for private study, on the understanding that it is copyright material, and that no quotation from the thesis may be published without proper acknowledgement”.

## ABSTRACT

If medical products were to possess the qualities of 'desirability' that are commonly associated with jewellery, positive user interaction would be enhanced. The wearer would be able to use medical products with pleasure and confidence, without fear or social stigma, and in doing so retain an element of personal control which might otherwise be lost to them.

This research addresses intersections between the two disciplines of craft and science of medicine. It focuses on developing new digital jewellery capable of monitoring the medical parameters of a patient as well as re-developing specific products such as the Asthma Inhaler, the Diabetic Insulin-Pen, and the Human Immunodeficiency Virus Medication Carrier. The aim in each case was to produce a more effective and user-friendly set of items. This research also facilitates the categorisation of jewellery artefacts which have a medical purpose, evaluating the benefits of devising new designs to ameliorate known problems, such as, iatrophobia (a phobia of seeking medical advice from a doctor or medical expert), or sociophobia (fear of being negatively judged in social situations).

CONTENTS  
**JEWELLERY AND MEDICINE**

<p><b>VOLUME I</b></p> <p>Copyright Statement, Abstract, <i>Contents</i>, List of Tables, List of Illustrations, Acknowledgments, Authors Declaration, Definitions, Acronyms and Terms, Jewellery and Craft</p> <p style="text-align: right;"><b>2</b></p> <p><b>INTRODUCTION</b> Motivation, Methodology, Focus Groups</p> <p style="text-align: right;"><b>25</b></p> <p><b>THE HISTORY OF MEDICAL JEWELLERY</b> Healing Jewellery, The Digital Age, A Look to the Future, Consultation with the TABPI</p> <p style="text-align: right;"><b>37</b></p> <p><b>BABY-BLUE GSR MODULE</b> The Future of Jewellery and Medicine, Touch Sensitive Jewellery, BABY-BLUE Technology, The BABY-BLUE GSR Circuit, Programming the BABY-BLUE GSR Module, Integrating BLUE Tooth Technology, BABY-BLUE Test Trials, Conductive Circuit Imagery, Re-designing the BABY-BLUE Circuit Board</p> <p style="text-align: right;"><b>62</b></p> <p><b>TOUCH SENSITIVE JEWELLERY</b> Fabricating Touch Slider Pads for Jewellery Applications, Curved Conductive Surface, Enclosed Jewellery, More Complex Medication Carriers, Demands to Improve the Self-Care Device, Conductive Gemstones, Portable BABY-BLUE Charger, Brief Introduction to the Three Case Studies</p> <p style="text-align: right;"><b>112</b></p>	<p><b>VOLUME II</b></p> <p><b>PROJECT ASTHMA</b> History of Asthma, Metered Dose Inhalers, Developing a new Asthma Inhaler Mechanism, Summary</p> <p style="text-align: right;"><b>148</b></p> <p><b>PROJECT DIABETES</b> The Beginnings of Diabetes Awareness, Patient Self-Care, Understanding Diabetes, Developing a New Home Glucose Measurement System (HGMS), A New Insulin Delivery System (IDS), A New Measurement Gauge, A New Safety Cap Design, The Development of the Disposable Needle Safety Guard, Preventing Needle Shift, Developing a Personalised Management Tool for the BABY-BLUE Software, Summary, Future Development</p> <p style="text-align: right;"><b>186</b></p> <p><b>PROJECT HUMAN IMMUNODEFICIENCY VIRUS</b> Understanding the Various HIV Treatments, Developing a Pill Carrier, Developing a New Flexible Watch, Summary</p> <p style="text-align: right;"><b>242</b></p> <p><b>CONCLUSION</b> Evaluation Phases, Research Methodology Review, Final Project Review, Consultations, Critical Reflection, Collaborative Research Thinking.</p> <p style="text-align: right;"><b>262</b></p> <p><b>VOLUME III</b> Appendices A-F, Bibliography</p> <p style="text-align: right;"><b>277</b></p>
--	---



## LIST OF TABLES

**Table 1:**  
Definitions, Acronyms and Terms p.22

### CHAPTER 2

BABY-BLUE GSR MODULE

**Table 2:**  
Additional Communication  
Features of the BABY-BLUE  
GSR module p. 96  
© Leon B M Williams  
Centre for Jewellery Research,  
Royal College of Art, London

### CHAPTER 3

TOUCH SENSITIVE  
JEWELLERY

**Table 3:**  
Technical Specifications for  
Conductive Imagery Limitations  
on Curved Surfaces p. 121  
© Leon B M Williams  
Centre for Jewellery Research,  
Royal College of Art, London

### CHAPTER 4

PROJECT ASTHMA

**Table 4:**  
Compatible Medicines for use with the New  
Slim-Line Inhaler p. 180  
© Leon B M Williams  
Centre for Jewellery Research,  
Royal College of Art, London

### CHAPTER 5

PROJECT DIABETES

**Table 5:**  
Conversion Chart – MMOL-L to MGDL  
p. 211  
© Leon BM Williams  
Centre for Jewellery Research,  
Royal College of Art, London

**Table 6:**  
Tolerances and Technical Specifications for  
the New Glucose Meter p. 212  
© Leon BM Williams  
Centre for Jewellery Research,  
Royal College of Art, London

**Table 7:**  
Compatible Insulin Types for use with the new  
IDS p. 234  
© Leon BM Williams  
Centre for Jewellery Research,  
Royal College of Art, London

**Table 8:**  
Compatible Needle Gauges used as part of the  
new IDS p. 235  
© Leon BM Williams  
Centre for Jewellery Research,  
Royal College of Art, London

## LIST OF ILLUSTRATIONS

### Fig. 1

**Photograph of Leon B M Williams**  
**Centre for Jewellery Research**  
England, 2008  
[Centre for Jewellery Research,](#)  
[Royal College of Art, London](#)

### Fig. 2

**Possible Addition to the Dictionary & Thesaurus**  
**Definition: Medical Jewellery**  
2008  
© Photoshop Image – By Leon Williams  
[Centre for Jewellery Research,](#)  
[Royal College of Art, London](#)

## INTRODUCTION

### Fig. 3

**Film Badge**  
**Radiology Module**  
2001  
England  
**Image Sourced from:**  
[www.osha.gov/.../radiology/images/bodybadge.jpg](http://www.osha.gov/.../radiology/images/bodybadge.jpg) [Accessed Oct 2007]

### Fig. 4

**Ring Badge**  
**Radiology Module**  
2001  
England  
**Image Sourced from:**  
[www.osha.gov/.../radiology/images/bodybadge.jpg](http://www.osha.gov/.../radiology/images/bodybadge.jpg) [Accessed Oct 2007]

### Fig. 5

**Climate-Cufflinks**  
England, 2004  
©Leon B M Williams  
Sterling silver and electronic circuit board  
H: 35 x W: 20 x D: 10mm  
[Private Collection](#)

### Fig. 6

**Pill-Carrier**  
England, 2004  
©Leon B M Williams  
Silver case, with glass component side anti-clockwise revealing a cavity in which pills are concealed  
H: 40 x W: 20 x D: 25mm  
[Royal College of Art, London](#)

### Fig. 7

**Talk - On The Subject of 'Historical Medical Jewellery'**  
2007,  
Speaker: Leon B M Williams.  
Findings sourced from separate galleries, museums, image libraries and private collections.  
Helen Hamlyn Research Centre, London  
[Royal College of Art, London](#)

### Fig. 8

**Focus Group Results - Showing the Position of Artefacts on a Jewellery and Medicine Scale.**  
**Talk On The Subject of 'Historical Medical Jewellery'.**  
2007,  
Speaker: Leon B M Williams.  
Findings sourced from separate galleries, museums, image libraries and private collections.  
Helen Hamlyn Research Centre, London  
[Royal College of Art, London](#)

## CHAPTER 1

### HISTORY OF MEDICAL JEWELLERY

### Fig. 9

Top Left:  
**Portrait of Infante Felipe Prospero by Diedo Velazquez**  
Spain, 1659  
Oil on canvas  
Kunsthistorisches Museum, Vienna  
Hansmann, L. & Kriss-Rettenbeck, L.1966,  
[Amulett und Talisman](#); Munchen: Verlag Georg D.W Callwey; p. 183, ill, 585  
Image commented by Leon Williams

Top Right:

**Doctor's Hearing Cane**

American, About 1900-1950

Ornate handle, accompanied by a syringe and glass bottle containing various implements

L: 920mm

[Online Auction](#)

Bottom Left:

**Prognosticator Instrument**

Possibly French, About 1538

Instrument used by medical practitioners of the mid 16th century to diagnose a patient complaint

Gilt ferrous metal

W: 50mm

Science Museum, London

[The Science Museum - Picture Library:](#)

London

Inv. no. 10315752

Bottom Mid Left:

**Doctor's Hearing Cane**

American, About 1900-1950

Brass hearing aid mounts to a partridge wood shaft.

920mm length.

[Online Auction](#)

Bottom Mid Right:

**Victorian Swan Shaped Ear-Trumpet**

England, Dated 1865

Ear Piece

Silver with engraving

by F C Rein and Son, English

[Science Museum/Science Museum](#)

[Picture Library, London](#) - Image no.

10284114

Bottom Right:

**Hypodermic Syringe**

England, Late 19th Century

Silver gilt with floral engraving

The Science Museum, Picture Library, London

Inv. no. 10284540

**Fig. 10**

**A Metal Orthopaedic Corset**

England, After 1837

Brass

Wellcome Trust Collection, London, (SM,A158256)

Arnold, K. & Olsen, D. eds. 2003,

[Medicine Man, The Forgotten Museum](#)

[of Henry Wellcome, London: The](#)

British Museum Press, p. 62

**Fig. 11**

**Collection of Fifty False Eyes**

Liverpool, England, 1936

Possibly made by E. Muller

Wellcome Trust Collection, London

Arnold, K. & Olsen, D. eds. 2003, [Medicine](#)

[Man, The Forgotten Museum of Henry](#)

[Wellcome, London: The British Museum](#)

Press, p. 65

**Fig. 12**

**Coloured Lithograph**

France, 1825

F-S Delpesch after L. Boilly, France.

The illustration depicts an elderly couple in the act of fitting their false teeth, artificial glass eye and wig.

Wellcome Trust Collection, London

Arnold, K. & Olsen, D. eds. 2003, [Medicine](#)

[Man, The Forgotten Museum of Henry](#)

[Wellcome, London: The British Museum](#)

Press, p. 64

**Fig. 13**

**Artificial Left Arm and Hand**

England, Dated around 1850-1910

Made from wood and leather and supported in position with leather sling-like straps and sprung thumb

Wellcome Trust Collection, London

[Wellcome Library, London](#), Inv no,

L0037136 Museum No. A653499

**Fig. 14**

**Body and Legs Brace**

American, *Early 19<sup>th</sup> Century*

Photograph

Stanley B. Burns

MD & The Burns Archive N.Y. / [Science](#)

[Photo Library, New York](#)

**Fig. 15**

**Doctor's Medical Cane**

American, About 1900-1950

Wooden Screw top with brass ridge,

revealing inner compartment where one syringe and several pill can be placed, all contained within a partridge wood shaft.

L: 920mm

[Online Auction](#)

**Fig. 16**

**Doctor's Medical Cane**

American, About 1900-1950  
Silver screw top- revealing a thermometer and protective brass case, all contained within a partridge wood shaft.

Possibly a replica  
L. 920mm

[Online Auction](#)

**Fig. 17**

**Family Photograph (with extract)**

England, 1880  
John Murray with Eleven Members of his Family, by unknown photographer. [National Portrait Gallery, London](#) Archive Collection – (NPGx126860)

**Fig. 18**

**Two Victorian Ear Trumpets**

England, 19<sup>th</sup> Century  
One made from tin designed to retract making it possible to fit into small bags, purses and pouches.  
One made in black silk for mourning by Atkinson, Union Court, Holborn Wellcome Trust Collection, London [Wellcome Library, London](#), Inv no, L0035642 Museum nos. A602553 & A129677

**Fig. 19**

**Victorian Swan Shaped Ear-Trumpet**

England, Dated 1865  
Ear Piece  
Silver with engraving by F C Rein and Son, English [Science Museum/Science Museum Picture Library, London](#) - Image no. 10284114

**Fig. 20**

**Revolving Hats Living Made Easy**

Published by T. McLean, London, England, 1830  
Men wearing top hats with attached aids  
Lithograph  
[Science Museum / Science Museum Picture Library, London](#), Image no. 10296563, Inv. no 1986-0264

**Fig. 21**

**Advertisement to promote the 'JC Boyd's Miniature Galvanic Battery Pendant'**

American, 1879  
Thomas, C. & Pena, D. L. Designing the electric body: Sexuality, Masculinity and the Electronic Belt in America 1880-1920', in: [Journal of Design History Society, England](#) (2001) Vol. 14, No .4, pp. 275-289

**Fig. 22**

**Advertisement for 'The Heidelberg Electric Belt'**

American, 1902  
Sears, by makers Roebuck & Co.  
Thomas, C. & Pena, D. L. Designing the electric body: Sexuality, Masculinity and the Electronic Belt in America 1880-1920', in: [Journal of Design History Society, England](#) (2001) Vol. 14, No .4, pp. 275-289

**Fig. 23**

**RevitaMed Infrared Therapy for Circulation Disorders**

American, 1990  
Made by LymphaCare, New Jersey, America New Jersey based LymphaCare, already a national provider of home lymphedema products  
is now offering as part of its product line for circulation disorders.  
[From www.emediawire.com](#)  
[Accessed 20 September 2007]

**Figs. 24, 25 and 26**

**Objects by Nicole Gratiot Stöber**

England, 1994  
Various working silver, ceramics, and plastics with inbuilt electronics  
Gilhooley, D. & Costin, S.1997, [Contemporary British Jewellery Unclasped](#), Alexiandra Bradley & Gavin Femades (eds.), London: Black Dog Publishing, p. 76- 77

**Fig. 27**

**Sony n1 touch\_menu 350**

England, 2006  
[www.sony.co.uk](#) [Accessed March 2007]

**Fig. 28**

**Skin-tile Jewellery Prototype**

German, 2007  
Stella Project - Developed by 11 electronic giants including PHILLIPS. The jewellery is programmed to reflect the wearer's mood  
[www.shinyshiny.tv/2007/10/skintile\\_skin\\_j.html](#) [Accessed November 2007]



**Fig. 29**

**Bone Wedding Ring**

January 23rd, 2007

London, England

Bio-jewellery was a collaboration between Tobie Kerridge, Nikki Stott and Ian Thompson, and was funded by the EPSRC

From online source:

<http://www.coolbusinessideas.com>

[Accessed January 2007]

**Fig. 30**

**Interchangeable Medic Alert Ring**

2007

Australia

Designed by Leah Heiss

Project supported by The Australian Network

for Art and Technology and

Nanotechnology Victoria

From online source:

<http://www.tuvic.com/diabetes-and-arsenic-jewelry-by-leah-heiss>

[Accessed April 2009]

**Fig. 31**

**Diamond Braille Dotted Ring**

2007

London, England

Designed by Stephen Einhorn

From online source:

<http://www.letstalkjewellery.co.uk/2007/06/26/diamond-braille-dotted-ring/>

[Accessed November 2007]

**Fig. 32**

**Gold and Diamond Digital Hearing Aid**

2008

Denmark

Widex

cast in solid 24-carat gold and encrusted with 220 diamonds, retail value £25,000.

From online source:

[http://sc.widex.com/?sc\\_lang=en](http://sc.widex.com/?sc_lang=en)

[Accessed March 2008]

**Fig. 33**

**Pomander in the Shape of a Skull**

German, 18<sup>th</sup> Century

Partially gilded silver

Croft Lyons Bequest

[Victoria and Albert Museum](#), London,

Case 11, Inv no. M.804:1, 2-1926

**Fig. 34**

**New Pomander in the shape of a Skull**

2009

England

Clear Plastic with Steel Pin,

© Designed and Made by Leon B M Williams

Centre for Jewellery Research,

[Royal College of Art, London](#)

**CHAPTER 2**

**BABY-BLUE GSR MODULE**

**Fig. 35**

**Schematic Diagram of the First Generation Body Acquisition Bio-Sensor**

2005

Schematic Diagram

© Leon B M Williams

Centre for Jewellery Research,

[Royal College of Art, London](#)

**Fig. 36**

**First Generation BABY-BLUE GSR Module**

2005

Photograph of prototype

© Leon B M Williams

Shadow Robotics, London

[Royal College of Art, London](#)

**Fig. 37**

**Second Generation BABY-BLUE Board Design Layout**

2005

Circuit board pattern, built in PCB (gedA)

© Leon B M Williams

Shadow Robotics, London

[Royal College of Art, London](#)

**Fig. 38**

**Handcrafting the BABY- BLUE GSR Module**

2006

Photograph of circuit board build

© Leon B M Williams

Shadow Robotics, London

[Royal College of Art, London](#)

**Fig. 39**

**Third Generation BABY-BLUE GSR Module Design**

2006

Photograph

© Leon B M Williams

Shadow Robotics, London

[Royal College of Art, London](#)

**Fig. 40**  
**Third Generation BABY-BLUE GSR**  
**Module with Lithium-ion 3.3v and**  
**Touch Sensitive Pad**

2006

Circuit board pattern, built in Illustrator

© Leon B M Williams

Centre for Jewellery Research,

Royal College of Art, London

**Fig. 41**  
**Assembling the Module (under**  
**magnification)**

2006

Micro Photograph

© Leon B M Williams

Shadow Robotics, London

Royal College of Art, London

**Fig. 42**  
**Eight Basic Light Emitting Diode**  
**Response Rhythms for the BABY-**  
**BLUE GSR Module**

2006

Graph – Illustrator and Excel

© Leon B M Williams

Centre for Jewellery Research,

Royal College of Art, London

**Fig. 43**  
**Touch Sensitive Pad**

2006

(a. through f.) Show the stages of  
making the transparent – touch pad  
Photographs of making of silver plated  
flexible substrates

© Leon B M Williams

Shadow Robotics, London

Royal College of Art, London

**Fig. 44**  
**PCB Programming Pipeline**

2006

Showing the laptop in circuit debugger and  
BABY-BLUE GSR Module

Photographs

© Leon B M Williams

Royal College of Art, London

**Fig. 45**  
**Interactive Personalised Metabolic**  
**Management Tool to Support BABY-**  
**BLUE GSR Module**

2007

Developed in Visual Studio and Expression  
Blend

© Leon B M Williams

Centre for Jewellery Research,

Royal College of Art, London

**Fig. 46**  
**Schematic Diagram to show Connection**  
**Between the 18F2480 Programmable**  
**Interrupt Controller (PIC) and the RN-41**  
**class BLUE-Tooth Module**

2007

Schema Diagram – Developed in Software

G-schema

© Leon B M Williams

Shadow Robotics, London

Royal College of Art, London

**Fig. 47**  
**Populated Sensor with RN4-BLUE-Tooth**  
**Module and 3.3v Lithium-ion Battery**

2007

Photograph

© Leon B M Williams

Royal College of Art, London

**Fig. 48**  
**Sequence of Photographs Detailing the**  
**Activation of the BABY-BLUE (GSR)**  
**Module**

2007

Set of 3 Photographs

© Leon B M Williams

Centre for Jewellery Research,

Royal College of Art, London

**Fig. 49**  
**Trial Testing the Galvanic Skin Response**  
**Module over a 24 hour period**

2007

AutoCAD, Illustrator and Photoshop

© Leon B M Williams

Centre for Jewellery Research,

Royal College of Art, London

**Fig. 50**  
**Trial Testing the Galvanic Skin Response**  
**Module over a 24 hour period**

2007

Photoshop

© Leon B M Williams

Centre for Jewellery Research,

Royal College of Art, London

**Fig. 51**  
**BABY-BLUE GSR Module**

2007

Photograph

© Leon B M Williams

Centre for Jewellery Research,

Royal College of Art, London

**Fig. 52**  
**Four BABY-BLUE GSR Printed Wiring**  
**Board Variations**

2007

Circuit board pattern, built in PCB (gedA) and  
Illustrator

© Leon B M Williams

Centre for Jewellery Research,

Royal College of Art, London

**Fig. 53**  
**Front and Back View of Four Etched**  
**BABY-BLUE GSR Circuit Variations**  
2007  
Photograph  
© Leon B M Williams  
Centre for Jewellery Research,  
[Royal College of Art, London](#)

**Fig. 54**  
**Front and Back View of Circular BABY-**  
**BLUE GSR Module Assembly**  
2007  
Photograph  
© Leon B M Williams  
Centre for Jewellery Research,  
[Royal College of Art, London](#)

**Fig. 55**  
**Flexible Conductive Substrates used to**  
**Connect the Flat-Rigid BABY-BLUE**  
**GSR Module to a Non-Uniform Touch**  
**Sensitive Surface**  
2007  
Illustrator and Photoshop  
© Leon B M Williams  
Centre for Jewellery Research,  
[Royal College of Art, London](#)

**Fig. 56:**  
**Scarab Pendant Design with Integrated**  
**BABY-BLUE (GSR) Module**  
2007 - 2008  
Illustrator Engineering Design  
© Leon B M Williams  
Centre for Jewellery Research,  
[Royal College of Art, London](#)

### **CHAPTER 3**

#### **TOUCH SENSITIVE JEWELLERY**

**Fig. 57**  
**(a. through i.) Four Different Possibilities**  
**for the BABY-BLUE Galvanic Skin**  
**Response Module - circuit etching and**  
**machining is used to achieve a compact**  
**printed circuit and touch sensitive pad**  
2008  
Set of Photographs  
© Leon B M Williams  
Centre for Jewellery Research,  
[Royal College of Art, London](#)

**Fig. 58**  
**(a. through c.) Show the Three Main**  
**stages to Make and Populate a Circuit**  
**Board for use with Conductive Imagery**  
**and a 128 x 128mm Colour Screen**  
2008  
Set of Photographs  
© Leon B M Williams  
Shadow Robotics, London  
[Royal College of Art, London](#)

**Fig. 59**  
**First Generation Touch-Slider with 128x128**  
**full Colour Display (based on the BABY-**  
**BLUE module)**  
2008  
Copper circuit on polymer substrate  
Photograph  
© Leon B M Williams  
Centre for Jewellery Research,  
[Royal College of Art, London](#)

**Fig. 60**  
**Dimensional Drawing of a Newly Developed**  
**Curved Surface Substrate**  
2008  
Rhino 3D drawing  
© Leon B M Williams  
Centre for Jewellery Research,  
[Royal College of Art, London](#)

**Fig. 61**  
**First Generation Substrates with Engraved**  
**Patterns**  
2008  
Envisiontec rapid prototyped finger shaped  
pad.  
E-Shell 100 resin  
Photograph  
© Leon B M Williams  
Centre for Jewellery Research,  
[Royal College of Art, London](#)

**Fig. 62**  
**Second Generation Substrates with**  
**Engraved Patterns and Through Holes**  
2008  
Envisiontec rapid prototyped finger shaped  
example of square pattern used to separate the  
conductive areas of the rapid prototyped finger  
shaped pad.  
E-Shell 100 resin  
Photograph  
© Leon B M Williams  
Centre for Jewellery Research,  
[Royal College of Art, London](#)

**Fig. 63**  
**Results Demonstrating the Optimum**  
**Spacing of Electrically Conductive Platelets**  
**Mounted Through and on Curved Surfaces**  
2008  
Virtual CAD simulations and Illustrator  
© Leon B M Williams  
Centre for Jewellery Research,  
[Royal College of Art, London](#)

**Fig. 64**  
**Conductive Imagery for use within**  
**Jewellery Applications**  
2008  
Virtual simulation set  
© Leon B M Williams  
Centre for Jewellery Research,  
[Royal College of Art, London](#)

**Fig. 65**  
**Bangle Simulation – Detailing the Interlocking Substrate Layers**  
2008

The exploded view shows all the parts that make up the bangle before rapid prototyping

Virtual design – Rhino 3D

© Leon B M Williams  
Centre for Jewellery Research,  
[Royal College of Art, London](http://www.royalcollegeofart.ac.uk)

**Fig. 66**  
**First Generation Bangle**  
2008

Black resin prototype and electronic parts– Before Plaiting

Photograph

© Leon B M Williams  
Centre for Jewellery Research,  
[Royal College of Art, London](http://www.royalcollegeofart.ac.uk)

**Fig. 67**  
**First Generation BABY-BLUE Pedometer Bangle Design. BABY-BLUE PB for short (*design simulation*) after Plaiting and Finishing Process**  
2008

Black resin bangle with gold circuit imagery inlay and electronic parts. The gold detailing makes up part of a working touch sensitive circuit

Virtual design

© Leon B M Williams  
Centre for Jewellery Research,  
[Royal College of Art, London](http://www.royalcollegeofart.ac.uk)

**Fig. 68**  
**Second Generation Bangles (design simulation) after Plaiting and Finishing Process**  
2008

Black resin bangle with gold circuit imagery inlay and electronic parts. The various gold detailing makes up part of a working touch sensitive circuit

Virtual design

© Leon B M Williams  
Centre for Jewellery Research,  
[Royal College of Art, London](http://www.royalcollegeofart.ac.uk)

**Fig. 69**  
**First Generation Pill-Pomander Design**  
2008

Virtual Design in Rhino3D, developed to hold and carry tablet medication within each compartment

© Leon B M Williams  
Centre for Jewellery Research,  
[Royal College of Art, London](http://www.royalcollegeofart.ac.uk)

**Fig. 70**  
**First Generation Pill-Pomander Design**  
2008

Rapid Prototype – Resin

The three photographs show the removal of the pomander directly after rapid prototyping. Once removed from the machine bed, the pomander is cleaned and then left to harden under ultra-violet light for approximately 30-45 minutes

© Leon B M Williams  
Centre for Jewellery Research,  
[Royal College of Art, London](http://www.royalcollegeofart.ac.uk)

**Fig. 71**  
**Images a through i show the Assembly of the Second Generation Pill-Pomander Design**  
2008

Resin pomander with steel pin joints on a long silver chain.

The pomander is demonstrated here by a researcher. The pomander is designed to hold 5 tablets of various sizes and could be used as a discreet way of concealing a patient's medication.

Photograph Sequence

© Leon B M Williams  
Centre for Jewellery Research,  
[Royal College of Art, London](http://www.royalcollegeofart.ac.uk)

**Fig. 72**  
**Third Generation Interchangeable Pill-Pomander**  
2008

Gold pomander with Black Resin Panels Design Simulation

The pill-pomander is developed carry different pill types. The wearer is given the ability to change and fit different covers, making the pill-pomander practical for long-term use.

© Leon B M Williams

Centre for Jewellery Research,  
[Royal College of Art, London](http://www.royalcollegeofart.ac.uk)

**Fig. 73**  
**Conductive Gemstones (brilliant cut) for Use in Jewellery Applications**  
2008

Illustrator

© Leon B M Williams  
Centre for Jewellery Research,  
[Royal College of Art, London](http://www.royalcollegeofart.ac.uk)

**Fig. 74**  
**Wax Gemstones (ready for casting into silver)**  
2008

The wax gemstones make up part of the conductive circuit that will be later used in digital jewellery

Photograph

© Leon B M Williams  
Centre for Jewellery Research,  
[Royal College of Art, London](http://www.royalcollegeofart.ac.uk)

**Fig. 75**  
**Conductive Gemstones (after casting and polishing)**

2008

The silver gemstones make up part of the conductive circuit that will be later used in digital jewellery

Illustrator

© Leon B M Williams

Centre for Jewellery Research,  
Royal College of Art, London

**Fig. 76**  
**Charge-Card Invention for use with BABY-BLUE Modules**

2007

Illustrator and Photoshop

© Leon B M Williams

Centre for Jewellery Research,  
Royal College of Art, London

**Fig. 77**  
**Photographic Sequence Detailing the Assembly of the BABY-BLUE Charge-Card Invention**

2007

Set of photographs

© Leon B M Williams

Centre for Jewellery Research,  
Royal College of Art, London

**Fig. 78**  
**Second Generation Universal Card-Charger Design**

2007

Illustrator design showing the arrangement of neodymium magnets on the charger surface. When the modules are placed in contact with the charger surface, parts of the electrical circuit become attracted to select parts on the charger

© Leon B M Williams

Centre for Jewellery Research,  
Royal College of Art, London

**Fig. 79**  
**(a. through to j.) Showing Ten Hexagonal Imagery Patterns used to Etch the Surface of the BABY-BLUE Charge-Card**

2007

Photograph

© Leon B M Williams

Centre for Jewellery Research,  
Royal College of Art, London

**Fig. 80**  
**CAD Exploded Diagram and 3Dimensional Simulation of the BABY-BLUE Card-Charger with Conductive Hexagonal Wire Pattern**

2007

CAD design in Rhino, Maya and Maxwell Render

© Leon B M Williams

Centre for Jewellery Research,  
Royal College of Art, London

## CHAPTER 4

### PROJECT ASTHMA

**Fig. 81**  
**Ebers Papyrus**

Ancient Egypt, About 1550 BC (16<sup>th</sup> dynasty)

One of the oldest preserved medical documents prescribing a mixture of herbs smoked over hot bricks so that the sufferer could inhale the fumes.

University College, London

Photograph from

[http://content.answers.com/main/content/wp/en-commons/c/c5/Papyrus\\_Ebers.png](http://content.answers.com/main/content/wp/en-commons/c/c5/Papyrus_Ebers.png)

[Accessed June 2008]

**Fig. 82**  
**The Mudge Inhaler**

England, 1778

Pewter mu-shaped inhaler

Wellcome Collection, London

Museum no. 765/66

Photograph from

<http://images.wellcome.ac.uk/-/L0010280>

[Accessed September 2007]

**Fig. 83**  
**Doctor Nelsons Improved Inhaler**

England, After 1865

Marbled with cork stopper – Still retains its glass spout

Made by: S Mawson and Thompson,

Aldergate St., London - Stock No. 14876

John Fox Antiques, Medical, Pharmacy and Scientific

**Fig. 84**  
**Victorian Inhaler named the 'Letheon' used for Ether Anaesthesia**

England, 1847 - 1848

Brass, glass and fabric

by Weiss T Morton's of London

The Science Museum Picture Library, London

Inv. no. A625399

Photograph from

<http://www.sciencemuseum.org.uk/objects/anaesthesiology-A625399> [Accessed September

2007]

**Fig. 85**  
**Sir Hiram Maxim's Pipe of Peace and Maxim Inhaler**  
1910  
Glass pipe corked at both ends and various cleaning implements  
The Science Museum, London – Making the Modern World Gallery –  
Inv. no. A629585  
Photograph from  
[http://www.sciencemuseum.org.uk/objects/anaesthesiology - A629585](http://www.sciencemuseum.org.uk/objects/anaesthesiology-A629585) [Accessed September 2007]

**Fig. 86**  
**Collection of Preventer Metered Dose Inhalers Designed to Support Aerosol Medication**  
2006-2008  
[Private Collection](#)

**Fig. 87**  
**Collection of Reliever Metered Dose Inhalers Designed to Support Aerosol Medication**  
2006-2008  
[Private Collection](#)

**Fig. 88**  
**Mother and Child Learning how to use an Asthma Inhaler Device with Spacer and Face Mask.**  
2006  
Colour Photograph from  
[www.allergvasthma.wordpress.com](http://www.allergvasthma.wordpress.com)  
[Accessed June 2007]

**Fig. 89**  
**Man using Breathing Apparatus**  
2006  
Black and White Photograph from  
[www.breathela.org/portal/asthma](http://www.breathela.org/portal/asthma)  
[Accessed June 2007]

**Fig. 90**  
**Elderly Lady using the Asthmatic device**  
1999  
Colour Photograph from  
BBC News. (1999) *Health - Asthma devices 'dissuade use'* [online], BBC News online, available from:  
<http://news.bbc.co.uk/1/hi/health/288611.stm> [Accessed 14 February 2005]

**Fig. 91**  
**A Teenage Asthma Patient using a Metered Dose Inhaler and Spacer Attachment**  
2008  
Photographic Sequence  
© Leon B M Williams  
Centre for Jewellery Research,  
[Royal College of Art, London](#)

**Fig. 92**  
**DIY Spacers for Asthma Attacks**  
2007  
Origami-Spacer being used by an asthmatic child demonstrating its use in a clinical setting  
Colour Photograph from  
<http://medgadget.com/archives/2007/08/respir-a-diy-spacers-for-asthma-attacks.html>  
[Accessed June 2007]

**Fig. 93**  
**Oral Thrush due to Corticosteroid Drugs for Asthma**  
2006  
Colour Photograph  
Science Photo Library, Harrow, London  
Inv. no. M130/332  
<http://www.sciencephoto.com/search/...>  
[Accessed December 2006]

**Fig. 94**  
**Oral Thrush due to the use of Becotide Inhaler**  
2006  
Colour Photograph  
Science Photo Library, Harrow, London  
Inv. no. M130/270  
<http://www.sciencephoto.com/search/...>  
[Accessed December 2006]

**Fig. 95**  
**(a. though d.) Trial Testing Various Nozzle Shapes to Control the Flow of Airborne and Globular Aerosol Medicines**  
2007  
Photograph, Illustrator and Photoshop  
© Leon B M Williams  
Centre for Jewellery Research,  
[Royal College of Art, London](#)

**Fig. 96**  
**First Generation Slim-Line Inhaler Mechanism**  
2007  
Rapid resin prototype model, Rhino, Illustrator and Maya  
© Leon B M Williams  
Centre for Jewellery Research,  
[Royal College of Art, London](#)

**Fig. 97**  
**First Generation Slim-Line Inhaler, being Trial Tested by a Volunteer**  
2007  
The following snapshots show how the volunteer assembled and used the mechanism with success in no more than 15 seconds without any assistance of prior knowledge of using the device  
Set of Colour Photographs of Resin rapid prototyped model  
© Leon B M Williams  
Centre for Jewellery Research,  
[Royal College of Art, London](#)

**Fig. 98**  
**Intersection Preview of Second Generation Slim-line Inhaler Mechanism**

2008  
Developed to hold, carry and administer aerosol medications  
Virtual Design Rhino 3D  
© Leon B M Williams  
Centre for Jewellery Research,  
[Royal College of Art, London](#)

**Fig. 99**  
**Standard Array of Interchangeable Covers for use by Children and Young Adults**

2008  
3D Designs - Maxwell Render  
© Leon B M Williams  
Centre for Jewellery Research,  
[Royal College of Art, London](#)

**Fig. 100**  
**Set of Images Showing the New Slim-line Inhaler Model**

2008  
Silver canister with clear resin case  
Colour Photograph  
© Leon B M Williams  
Centre for Jewellery Research,  
[Royal College of Art, London](#)

**Fig. 101**  
**Design Sketch of Thumb Grip and Chain Attachment**

2009  
Ink on paper  
© Leon B M Williams  
Centre for Jewellery Research,  
[Royal College of Art, London](#)

**Fig. 102**  
**3-Dimensional Drawings of the Slim-line Inhaler with Rubber Thumb Grip Design and Chain Loop**

2009  
Rhino and Solid works  
© Leon B M Williams  
Centre for Jewellery Research,  
[Royal College of Art, London](#)

**Fig. 103**  
**Gold Slim-line Inhaler with Silver Grip and Engraved Canister**

2009  
© Leon B M Williams  
Centre for Jewellery Research,  
[Royal College of Art, London](#)

**Fig. 104**  
**New Label Designs, for use with the Slim-line Inhaler - Sabutamol & Beclazone Medicines**

2009  
Illustrator  
© Leon B M Williams  
Centre for Jewellery Research,  
[Royal College of Art, London](#)

**Fig. 105**  
**Design Proposal for New Slim-line Inhaler**

2009  
3D Designs Maxwell Render  
Black plastic with gold detailing and integrated rotating mouth guard / safety cap  
© Leon B M Williams  
Centre for Jewellery Research,  
[Royal College of Art, London](#)

## CHAPTER 5

### PROJECT DIABETES

**Fig. 106**  
**Hypodermic Syringe**  
England, Late 19th Century  
Silver gilt with floral engraving  
The Science Museum, Picture Library, London  
Inv. no. 10284540  
Photograph from  
<http://www.sciencemuseum.org.uk/objects/>  
[Accessed September 2007]

**Fig. 107**  
**24 Procedural Steps to Prepare, Make Ready and Use a Home Glucose Monitoring System**

2008  
Set of Colour Photographs  
© Leon B M Williams  
Centre for Jewellery Research,  
[Royal College of Art, London](#)

**Fig. 108**  
**(a. through c.) Three of the Most Popular Spring Loaded Lancet Mechanisms that are used by Diabetic Patients**

2006  
Set of Colour Photographs  
© Leon B M Williams  
Centre for Jewellery Research,  
[Royal College of Art, London](#)

**Fig. 109**  
**3-Dimensional Model – New Lancet Mechanism for Extracting a Droplet of Whole Blood for Testing**

2007  
L:40mm  
CAD Design  
© Leon B M Williams  
Centre for Jewellery Research,  
[Royal College of Art, London](#)

**Fig. 110**  
**Perspective View of 3-Dimensional Model – New Lancet Mechanism for Extracting a Droplet of Whole Blood for Testing**

2007  
L:40mm  
CAD Design  
© Leon B M Williams  
Centre for Jewellery Research,  
[Royal College of Art, London](#)

**Fig. 111**  
**Extracting a Sample of Whole-Blood using the Newly Developed Lancet Mechanism**

2008  
Illustrator Drawing  
© Leon B M Williams  
Centre for Jewellery Research,  
[Royal College of Art, London](#)

**Fig. 112 (top), 113 (bottom left) & 114 (bottom right)**  
**Trail Testing the New Lancet Mechanism**

2008  
Resin (type R11) and steel  
Testing the newly developed lancets on two individuals with different skin thickness  
Colour Photographs  
© Leon B M Williams  
Centre for Jewellery Research,  
[Royal College of Art, London](#)

**Fig. 115**  
**Mechanical Parts of the Accu-Check Glucose Meter and Lancet**

A popular Glucose Meter and Lancet Mechanism  
2007  
Photographs  
© Leon B M Williams  
Centre for Jewellery Research,  
[Royal College of Art, London](#)

**Fig. 116**  
**A New Circular Whole-Blood Test Strip for use with the Newly Developed Lancet Mechanism and Glucose Meter**

2008  
Illustrator Drawing and Photography  
© Leon B M Williams  
Centre for Jewellery Research,  
[Royal College of Art, London](#)

**Fig. 117**  
**First Generation Digital Glucose Meter using Two Analysis Methods – Exploded View**

2009  
Note: The lancet developed here uses a micro-syringe to draw a sample of whole blood into a controlled and sterile space of reaction chamber made ready for analysis using amperometric technology. To immobilise the enzymes self-assembled monolayer's are used so the sensitivity and reproducibility of the electrochemical response will improve  
Illustrator Drawing and 3D CAD  
© Leon B M Williams  
Centre for Jewellery Research,  
[Royal College of Art, London](#)

**Fig. 118**  
**45 Procedural Steps to Prepare, Make Ready and Administer Insulin, using a Traditional Insulin Delivery Pen**

2008  
Set of Colour Photographs  
© Leon B M Williams  
Centre for Jewellery Research,  
[Royal College of Art, London](#)

**Fig. 119**  
**Three Insulin Delivery Devices**

2007  
AutoPen (top), NovaPen (middle), Manual Syringe (bottom)  
Colour Photographs  
© Leon B M Williams  
Centre for Jewellery Research,  
[Royal College of Art, London](#)

**Fig. 120**  
**A Collection of Design Sketches, that Challenge the Pragmatic Mechanical Problems to Hold, Carry and Stabilise the Flow of Insulin as it is Administered by the Patient**

2008  
Ink on paper  
© Leon B M Williams  
Centre for Jewellery Research,  
[Royal College of Art, London](#)

**Fig. 121**  
**Final Design Sketch of the Newly Developed Insulin Delivery Pen**

2008  
Ink on paper  
© Leon B M Williams  
Centre for Jewellery Research,  
[Royal College of Art, London](#)



**Fig. 122**  
**Insulin Delivery Pen**  
2008  
3-Dimensional rapid prototyped model showing the inner workings of the newly developed insulin delivery pen  
Z-CORE Technology  
© Leon B M Williams  
Centre for Jewellery Research,  
[Royal College of Art, London](#)

**Fig. 123**  
**Rapid Prototyped Measurement Gauge, for use as part of the New Insulin Delivery System - IDS**  
2008  
Rapid Prototyped Resin and Envision Technology  
© Leon B M Williams  
Centre for Jewellery Research,  
[Royal College of Art, London](#)

**Fig. 124**  
**New Compact Bung and Integrated Plunger Design**  
2008  
Rapid Prototyped (Envision-technology)  
© Leon B M Williams  
Centre for Jewellery Research,  
[Royal College of Art, London](#)

**Fig. 125**  
**35 Participants discussing the Various Types of Needle Phobia**  
2007  
Colour Photograph  
© Leon B M Williams  
Centre for Jewellery Research,  
[Royal College of Art, London](#)

**Fig. 126**  
**Using a Typical Insulin Device**  
Participant in this sequence is highlighting the practical difficulties of using a typical IDS and needle  
2008  
Colour Photograph  
© Leon B M Williams  
Centre for Jewellery Research,  
[Royal College of Art, London](#)

**Fig. 127**  
**Design Simulation, Detailing the New Disposal Needle Safety Guard Invention. Developed here to Reduce the Risk of Needle Stick Injuries**  
2008  
Maxwell Render  
© Leon B M Williams  
Centre for Jewellery Research,  
[Royal College of Art, London](#)

**Fig. 128**  
**Mechanical Simulation Showing the Newly Developed Safety-Cap Design in its Active and Non-Active State.**  
2008  
(Left Image) shows the cap locked  
(Right Image) shows the needle in a plunged position  
Maxwell Render  
© Leon B M Williams  
Centre for Jewellery Research,  
[Royal College of Art, London](#)

**Fig. 129**  
**© The Sequence Shows a Participant Administering Insulin using the NovaPen**  
2007-2008  
The image shows the difficulty of handling the device, whilst trying to avoid sensitive parts of the body. The three images show how the patient balances the pen whilst positioning the needle.  
Colour Photographs  
Leon B M Williams  
Centre for Jewellery Research,  
[Royal College of Art, London](#)

**Fig. 130**  
**First Generation Needle Tilt Sensor**  
2008  
Rapid prototyped pen with quantum tunnelling composite pressure sensor developed to monitor needle-movements when administering insulin subcutaneously  
Electronics, resin assembled prototyped circuit board  
© Leon B M Williams  
Shadow Robotics, London  
[Royal College of Art, London](#)

**Fig. 131**  
**Trial Testing the Tilt Sensor**  
Second generation needle tilt sensor  
2008  
With a tiger orange organic light emitting diode screen  
© Leon B M Williams  
Shadow Robotics, London  
[Royal College of Art, London](#)

**Fig. 132**  
**© Recommended Locations on the Body for the Administration of Insulin using the Newly Developed IDS**  
2009  
Illustrator  
Leon B M Williams  
Centre for Jewellery Research,  
[Royal College of Art, London](#)

## CHAPTER 6

### PROJECT HIV

#### Fig. 133

##### White Pill Box with Medication

2008

7 Compartments with air-tight seals

Photograph from

[http://blogs.dogster.com/vet\\_blog\\_information\\_advice/files/2008/10/800px-pill\\_box\\_with\\_pills.JPG](http://blogs.dogster.com/vet_blog_information_advice/files/2008/10/800px-pill_box_with_pills.JPG) [Accessed September 2008]

#### Fig. 134

##### Anti-viral Medication

2008

Photograph from

[http://blogs.poz.com/mark/upload/Dinner\\_Pills.jpg](http://blogs.poz.com/mark/upload/Dinner_Pills.jpg)  
[Accessed September 2008]

#### Fig. 135

##### Top, Front, Right and Perspective view of the First Generation BABY-BLUE Cube Design

2008

3-Dimensional Design built in the software packages Solid works and Rhino 3D

© Leon B M Williams

Centre for Jewellery Research,  
[Royal College of Art, London](http://www.royalcollegeofart.ac.uk)

#### Fig. 136

##### Set of Rapid Prototyped BABY-BLUE Cubes

2008

Resin (Envision Technology)

H: 30 x W: 30 x D: 10mm

© Leon B M Williams

Centre for Jewellery Research,  
[Royal College of Art, London](http://www.royalcollegeofart.ac.uk)

#### Fig. 137

##### BABY-BLUE Cubes with Integrated Disk Magnets

##### Demonstrated Fixed to Refrigerator Door

2008

Colour Photograph

© Leon B M Williams

Centre for Jewellery Research,  
[Royal College of Art, London](http://www.royalcollegeofart.ac.uk)

#### Fig. 138

##### Final BABY-BLUE Cube Concept Design with Integrated Magnets

2008

Clear plastic, silver panels

© Leon B M Williams

Centre for Jewellery Research,  
[Royal College of Art, London](http://www.royalcollegeofart.ac.uk)

#### Fig. 139

##### 32 inch Silver Chain with Detachable Magnetic Pill Boxes

2008

© Leon B M Williams

Centre for Jewellery Research,  
[Royal College of Art, London](http://www.royalcollegeofart.ac.uk)

#### Fig. 140

##### Combination Antiretroviral Medicine Routine for Patients living with HIV; based on Helen M Miramontes Clock Face System

2008

Illustrator

Example from Participant

© Leon B M Williams

Centre for Jewellery Research,  
[Royal College of Art, London](http://www.royalcollegeofart.ac.uk)

#### Fig. 141

##### Schematic diagram of BABY-BLUE Watch

2008

Schema

© Leon B M Williams

Centre for Jewellery Research,  
[Royal College of Art, London](http://www.royalcollegeofart.ac.uk)

#### Fig. 142

##### BABY-BLUE Watch Layout Patterns – Multi Layered Design for Flexible Substrate

2008

PCB and Illustrator

© Leon B M Williams

Centre for Jewellery Research,  
[Royal College of Art, London](http://www.royalcollegeofart.ac.uk)

#### Fig. 143

##### Photographic Sequence Showing the Print and Etch Process for Fabricating a Flexible BABY-BLUE Watch Circuit Board

2008

Set of Photographs

© Leon B M Williams

Centre for Jewellery Research,  
[Royal College of Art, London](http://www.royalcollegeofart.ac.uk)

#### Fig. 144

##### Testing the New Circuit Pattern Configuration, using a Process Known as 'A-Bed-of-Nails'

2008

Photograph

© Leon B M Williams

Centre for Jewellery Research,  
[Royal College of Art, London](http://www.royalcollegeofart.ac.uk)

#### Fig. 145

##### Soldiering the Components Together to Form the Basis of the BABY-BLUE Watch

2008

Photograph

© Leon B M Williams

Centre for Jewellery Research,  
[Royal College of Art, London](http://www.royalcollegeofart.ac.uk)

**Fig. 146**  
**Trial Testing the BABY-BLUE Watch**  
2008  
Photograph  
© Leon B M Williams  
Centre for Jewellery Research,  
Royal College of Art, London

## **CONCLUSION**

**Fig. 147**  
**Focus Group**  
**Discussing the value and purpose of**  
**medical jewellery**  
2008  
Photograph  
© Leon B M Williams  
Centre for Jewellery Research,  
Royal College of Art, London

**Fig. 148**  
**Dealing with Social Phobias**  
1997  
Black and White Photography  
© Leon B M Williams  
University of Coventry, England

**Fig. 149**  
**Power Point Snap Shot**  
Detailing letters and patient questionnaire  
results  
2005-2007  
Talk Conducted at the Royal College of Art,  
London  
© Leon B M Williams  
Centre for Jewellery Research,  
Royal College of Art, London

## ACKNOWLEDGEMENTS

I am very much indebted to all those who participated in this project and for their contribution of time and expertise on the study of jewellery and medicine. It was indeed an honour to work with such a wonderful selection of researchers from many different academic and commercial fields. Special thanks go to the following who generously contributed their time: Professor David Watkins (Supervisor), Dr Beatriz Chadour-Sampson (Supervisor), Professor Hans. Stofer (Head of Department, GSMJ), Dr Neil Tsang (Imperial College), Niamh Murphy (Medic Assist), Dr Ian Lamb (Leith Mount Surgery, Edinburgh), Dr David Humphrey (Centre for Jewellery Research, RCA, London), Hugo Elias (Shadow Robotics, London), Karen Orwin (University of Central London), Rama Gheerawo (Helen Hamlyn Foundation, RCA), Professor Jim Williamson (Imperial College), Dr Tony Holland (University of Cambridge), Dr Phil Berry (Boots Healthcare), Colum Menzies Lowe (NHS).

*Special thanks go to the Arts and Humanities Research Council for awarding me the financial means for this research.*

Copyright 2008 by Leon Brett Mathew Williams, Royal College of Art, London: All designs and accompanying documentation retain a non-exclusive and non-transferable license to exercise all rights provided by copyright. Final reports are distributed by the Research Office, Royal College of Art, Kensington Gore, London. Department of Goldsmithing, Silversmithing Metalwork & Jewellery.

## AUTHOR'S DECLARATION

1. During the period of registered study in which this thesis was prepared the author has not been registered for any other academic award or qualification.

2. The material included in this thesis has not been submitted wholly or in part for any academic award or qualification other than that for which it is now submitted.

Leon B M Williams  
April 2009

For purposes of clarity, and to avoid repetition, Table 1 defines definitions, acronyms and terminologies used throughout this thesis.

**TABLE 1: DEFINITIONS, ACRONYMS AND TERMS**

<i>General</i>	BABY-BLUE	Body Acquisition Bio-sensory Jewellery with integrated BLUE-Tooth capabilities
	BUPA	British United Providence Association
	CAD	Computer Aided Design
	DDA	Disability Discrimination Act 2005
	DLF	Disabled Learning Foundation
	DRC	Disability Rights Commission
	GSR	Galvanic Skin Response
	GUI	General User Interface
	MHRA	Medicines and Healthcare Products Regulatory Agency
	MJ	Medically Jewellery
	NHS	National Health Service
	NICE	National Institute for Clinical Excellence
	OLED	Organic Light Emitting Diode
	PCB	Printed Circuit Board
	PIC	Programme Interrupt Controller
	PUI	Patient User Interface
	PWB	Printed Wiring Boards
	PWP	Printed Wiring Patterns
	Rx	Abbreviation for prescription medication
	TABPI	Trade Association for the British Pharmaceutical Industry
<i>Project Asthma</i>	BA-MDI	Breath Actuator – Metered Dose Inhaler
	COPD	Chronic Obstructive Pulmonary Disease
	DPI	Dry Powder Inhaler
	MDI	Metered-Dose Inhaler (small device for administering asthma medication)
<i>Project Diabetes</i>	Beta cells	Cells in the pancreas which should produce insulin
	BG	Blood Glucose
	BMI	Body Mass Index
	Correction Bollus	If blood glucose level is high, insulin can bring it down to a normal level
	DM	Diabetes Mellitus
	HGMS	Home Glucose Measurement System
	IDS	Insulin Delivery System
	mmol/L	Millimoles per litre. A common unit for measuring blood glucose levels
	T1	Type 1 diabetes. Insulin dependent diabetes mellitus
	T2	Type 2 diabetes. Non insulin dependent diabetes mellitus
<i>Project HIV</i>	AIDS	Acquired Immune Deficiency Syndrome
	HIV	Human Immune Deficiency Virus

## JEWELLERY AND CRAFT

*- Identifying the Importance of Craft when Developing Medical Jewellery -*

I believe that all jewellery shares one characteristic – It is designed to be carried close to the body and valued as an object of curiosity when removed. Jewellery for me, at its most basic level, evokes personal meaning by strengthening the bond between the wearer and their memories. Jewellery can be made of expensive or cheap materials and hold great sentimental value depending upon the significance given to it by its current owner. It is not just an accessory or component; it is an object that is not truly complete without its reciprocal partnership of the body.

An item of Medical Jewellery for me is very particular kind of object with a dual purpose. It should be safe to wear and comfortable to hold. There are two craft approaches that come into play when developing medical jewellery. The first is the practical craft of making to a high quality. The second and more importantly is crafting to the needs of the patient. On a practical level, it is the designers' responsibility to resolve the technical difficulties of wearing and carrying different medicine types on or close to the body. It is my belief that until pharmaceutical companies consider these two approaches at all stages in research development, from concept to creation, the potential of medical jewellery can not be fully realised. The challenge however is how jewellery can be used in a creative way to develop a more personalised

medication delivery system that could help to humanise medical devices made for mass production. The following definition summarises in my own words some of the key characterising features of three common Medical Jewellery types.

<< Content Page

**Fig. 1**

Photograph of Leon B M Williams  
Centre for Jewellery Research  
2008  
England

Centre for Jewellery Research,  
Royal College of Art, London

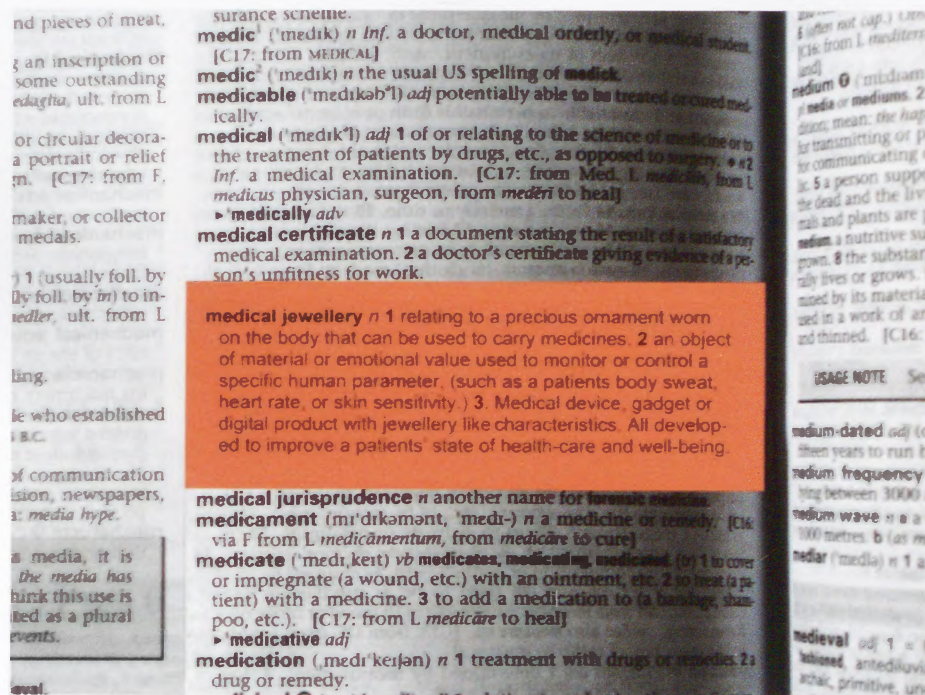

**Fig. 2**

Possible Addition to the Dictionary &  
Thesaurus  
Definition: *Medical Jewellery*  
2008

Centre for Jewellery Research,  
Royal College of Art, London



# INTRODUCTION

<b>MOTIVATION</b> <i>Past and Present Research</i>	26
<b>METHODOLOGY</b> <i>Research Approach</i>	29
<b>FOCUS GROUPS</b> <i>Volunteers Critical Contribution</i>	35

## MOTIVATION

- Past and Present Research -

For several years I have been working to develop ‘medical jewellery’ for numerous individuals who suffer from one or more medical conditions. My motivation in researching and designing medical jewellery has come from the ever growing need to ‘humanise’ and ‘improve’ a number of existing invasive medical products. The aim of this research was to tackle sensitive issues relating to patients’ experience of these products and to develop new digital jewellery possibilities that could be deployed in monitoring the progress of a patient’s short-term condition or long-term disability in new ways.

As a maker, I am inspired by portable gadgetries designed for a medicinal purpose and worn as jewellery. This interest with self-care body adornments stems from my first encounter with what I recognised as one type of medical jewellery. The ring and film badge shown in the following figs are similar to those given to me at Guy’s Hospital, London, in 2001-2002. They were designed to be worn by staff as a preventative measure detecting radiation overexposure when working with different patients undergoing radiology treatment.



**Fig. 3**  
Film Badge  
Radiology Module  
2001  
England

Image Sourced from:  
[www.osha.gov/.../radiology/images/bodybadge.jpg](http://www.osha.gov/.../radiology/images/bodybadge.jpg) [Accessed Oct 2007]



**Fig. 4**  
Ring Badge  
Radiology Module  
2001  
England

Image Sourced from:  
[www.osha.gov/.../radiology/images/bodybadge.jpg](http://www.osha.gov/.../radiology/images/bodybadge.jpg) [Accessed Oct 2007]

My earlier work developing alternative medical devices having jewellery characteristics has proved highly beneficial to participants. In fact, this inclusive design approach has inspired me to continue progressing medical jewellery, as it helps alleviate many phobias and fears and at the same time improves the way in which people carry and administer their medicine. Figs. 5 and 6 illustrate earlier pieces made between 2002 and 2004 which initiated this project. Note: the climate cufflinks were designed to record personal data about the body and the pill-container was designed to hold and carry tablet medications in times of need.



**Fig. 5**

Climate-Cufflinks

2004

England

© Leon B M Williams

Sterling silver and electronic circuit board

H:35 x W:20 x D:10mm

Private Collection



**Fig. 6**

Pill-Carrier

2004

England

©Leon B M Williams

Silver case, with glass component side anti-clockwise  
revealing a cavity in which pills are concealed

H:40 x W:20 x D:25mm

Royal College of Art, London

## METHODOLOGY

- Research Approach -

This research does not follow a conventional scientific methodology; it is more of an insight into the key decisions which have shaped my process of thought as a craftsman/researcher. To begin, this research focuses on historical jewellery artefacts which have been used to cure, remedy or protect the body against illness, disease and in some cases death. It will, in brief, contextualise a selection of artefacts with amuletic, prophylactic or medicinal properties. Chapter 1 titled '*Healing Jewellery*' draws together a few key artefacts that gave me an insight into the mindset of people at different times in history, the fears they faced and how jewellery functioned as a survival aid. Note: this chapter is supported by a more in-depth analysis consisting a larger selection of artefacts from pre-historic times to the modern day (see Appendix A entitled '*Magic Marvel, and Medicine*'). All resource material shown in this thesis has been carefully selected to reveal the impact that different jewellery types have had on society, showing how shifts in politics, economics and religion have at various times impacted on the development or curtailment of jewellery used for medicinal purposes. This section ends with a critical discussion on current jewellery, examining how I have taken historical jewellery approaches and philosophies and re-interpreted them in the light of current thinking<sup>1</sup> today, evolving a new and advanced classification of medical jewellery. It will also bring to focus the

---

<sup>1</sup> Anderson, A (2003) *Could jewellery make you ill?* Daily Mail, 29 April [online]:<http://www.dailymail.co.uk/health/article-178737/Could-jewellery-make-ill.html> [Accessed June 2006]

importance of contemporary medical jewellery projects championed by specialists from the fields of both craft and science.

The discussion will then lead into the next chapter with a more focused overview of future medical jewellery technologies. Here, in Chapter 2, a new body acquisition bio-sensory jewellery type is developed. It details the most important stages in prototype development, from conception to creation, including the programming of the algorithms needed to control the wireless components. Each product design 'generation' has been documented to show the critical assessment and volunteer trial testing phases to expose any design or fabrication faults. The purpose of this chapter is to show how new digital technologies can, with guidance, be integrated in wearable products on a jewellery scale. At this point in the research, I have developed a system whereby jewellery is capable of monitoring the medical parameters of a patient, such as sweat, body heat, and skin sensitivity, which will provide the patient's personal data relating to their medical condition. The products developed are easy to use, comfortable for the wearer and contain devices which encourage user-interaction including an element of pleasure in the wearing of jewellery.

Chapter 3 focuses on the development and integration of a new 'touch-sensitive technology'. A step-by-step approach is taken to clearly demonstrate the thought processes involved in making a fully working touch-sensitive digital jewellery product that could be used, in part, to

control and protect the sensitive components. This chapter further brings to light the pragmatic challenges of fabricating rigid, flexible and free-form touch-sensitive circuits used as an interactive sensor on and through the surface of jewellery. It is supported by a discussion on the demands to improve self-care devices, critically reviewing whether touch technologies are appropriate for use by pharmaceutical design developers.

Digital technology is all-important in the preparatory technological developments used to support three medical products central to this project: the asthma inhaler, the diabetic pen, and the HIV medication carrier. The choice of the asthma inhaler and the diabetic pen is based on the fact that existing products have hardly changed in recent times, and the HIV medication carrier is non-existent. The challenge lies in how to improve existing medical products by embedding new technologies into jewellery designs whilst retaining the aesthetics and pleasures of wearing jewellery.

To summarise, the main reasons for developing these three products were:

- To develop or invent three medical products that demand different design approaches.
- To make three case studies that best demonstrate how new medical jewellery technologies could be used to control aerosol, liquid and tablet medicines.
- To demonstrate how skills from the disciplines of jewellery and medicine can be legitimately brought together in the development of future medical devices.
- To develop a new and superior technologies or medical jewellery products.
- To develop three medical products that ameliorate social anxieties and fears.

Each chapter in this section focuses on developing a new and improved set of products. For continuity reasons, all three case studies follow the same structural criteria, beginning with a brief history of the condition and the devices / inventions used by patients to remedy, suppress, or heal its symptoms. This is followed by a product development phase, identifying the key medical problematics that arise in using current medical products. Initial concept designs follow. Here patients' feedback and reviews take priority in the prototyping stages, finishing with a summary, evaluating the final medical jewellery designs. Note: Project Diabetes proved to be more complex and has therefore taken longer to develop technologies that could be used to realise a fully working delivery system.



Finally, Chapter 7 questions the case for developing medical jewellery for better patient care and ends with a critical discussion on whether medical products used today have a negative effect on the daily activities of consumers, and what personal psychological values could be gained by wearing more desirable precious jewellery objects. This chapter also includes an assessment of how the wearing of medical jewellery can be made more appealing while retaining its function. It also reflects critically on the advancements and drawbacks of medical products and comes to the conclusion that they do indeed make a contribution to the wearer's quality of life.

As a researcher, it is my responsibility to develop products which give patients more control over their medical condition, to help them lose their anxieties and fears and interact with their medical device on a more personal level. Trial-testing and product simulations cover a variety of disciplines including the medical sciences, design engineering, jewellery design, electronics and addressing issues of intellectual property.

Due to issues of sensitivity and the need for anonymity it was necessary for me as a researcher to identify the most common concerns made in patient consultations, focus groups or one-on-one interviews. In the light of these difficulties the method used to obtain confidential information was to collect and analyse data through website virtual interactions and to

try shadowing professionals from pharmaceutical and jewellery design companies.

The following consultations techniques included:

- talks with patient volunteer groups
- experiments with volunteer groups
- patient questionnaires on issues of medical jewellery
- one-on-one patient interviews
- patient and practitioner shadowing
- email and phone conferences with industrial manufactures
- open forum talks with specialists
- product trial testing
- peer reviews

Appendix F titled '*The Voice of Reason*' provides more patient interviews, questionnaires, letters, and transcription. Note: Some sections of each document will have been omitted to ensure anonymity when requested by the patient or practitioner. All studies were conducted within the Centre for Jewellery Research, Royal College of Art, London and Shadow Robotics Engineering, London. The results of this research are potentially important for makers, designers, and engineers alike. The research is focused on producing reference material on the principles of medical jewellery, which in the future will hopefully be taken into consideration by specialist practitioners and recognised by major organisations including the Medicines and Healthcare Products Regulatory Agency M.H.R.A.

## FOCUS GROUPS

- *Volunteers Critical Contribution* -

Patient consultations and focus groups were conducted early in the research, this being an effective way to involve volunteers whilst drawing upon their experiences. By openly sharing different ethical views and practical concerns about the direction, development and placement of medical jewellery, the participants felt involved in the development process which, in part, gave them a strong position to contribute to the development of a new exciting product. Equally, such consultations have enabled me to evaluate, test and analyse working prototypes with confidence. The volunteers helped me contextualise medical jewellery types and devices that I gathered from the literature.



**Fig. 7**

Talk On the Subject of  
'Historical Medical Jewellery'.  
2007,  
Speaker: Leon B M Williams.

Findings sourced from separate  
galleries, museums, image  
libraries and private collections.

Helen Hamlyn Research Centre  
London  
Royal College of Art, London

Over the period of the research, I have given several talks on the subject of medical jewellery history. I also conducted a small social experiment that was designed to actively encourage participants to place one hundred artefacts on a scale according to their jewellery or medicine features. Figs .7 and .8 show the final results.



**Fig. 8**

Focus Group Results Showing the Position of Artefacts on a Jewellery and Medicine Scale. Talk on the subject of '*Historical Medical Jewellery*'. 2007, Speaker: Leon B M Williams. Findings sourced from separate galleries, museums, image libraries and private collections.

Helen Hamlyn Research Centre, London  
Royal College of Art, London

The results revealed that most of the artefacts retained both 'jewellery' and 'medicine' characteristics. All the volunteers had, unknowingly, helped in the selection process whilst confirming that there are many more discussions to be had on the subject of medical jewellery.

# CHAPTER 1

## HISTORY OF MEDICAL JEWELLERY

**HEALING JEWELLERY**  
*n Evolution of 'Healing Jewellery' Design and 19th Century Gadgetry*

38

**THE DIGITAL AGE**  
*Contemporary Medical Jewellery Projects*

50

**A LOOK TO THE FUTURE**  
*The Path to Digital Jewellery*

58

**CONSULTATION WITH THE TABPI**  
*Trade Association for the British Pharmaceutical Industry*

60

## HEALING JEWELLERY

- An Evolution of 'Healing Jewellery Design and 19th Century Gadgets -

In its long history, jewellery was not only adornment. Since the dawn of time men, women and children have worn jewellery to serve as a sign of status. It also played an important role in everyday life and people's survival against the forces of nature. From its early beginnings jewellery was closely linked to superstitious beliefs, and even today after centuries of scientific innovations and new technologies the belief that jewellery can safe-guard man against illnesses, disease, or even death, still continues.



**Fig. 9**

**Top Left:** Portrait of Infante Felipe Prospero, by Diego Velazquez, 1659, oil on canvas

**Top Right:** Doctor's Hearing Cane. About 1900- 1950. American L: 920mm. Ornate handle, accompanied by a syringe and glass bottle containing various implements. Private Collection

**Bottom Left:** Prognosticator Instrument. About 1538. Possibly French. Gilt ferrous metal. W: 50mm. Instrument used by medical practitioners of the mid 16th century to diagnose a patient complaint illness. Science Museum Picture Library, London

**Bottom Mid Left:** Doctor's Hearing Cane. About 1950. American L: 920mm. Brass, hearing aide mounts to a partridge wood shaft. Private Collection

**Bottom Mid Right:** Victorian Swan Shaped Ear-Trumpet, Ear Piece. Dated 1865, England. Silver with engraving, by F C Rein and Son. Science Museum Picture Library, London. Picture Library – Image no. 10284114

**Bottom Right:** Hypodermic Syringe. England. Late 19th Century. Silver gilt with floral engraving. The Science Museum, Picture Library, London. Inv. no. 10284540

Around the mid 19<sup>th</sup> century, scientific research had become more sophisticated in its methodological approach to health and medicine. Such ramifications encouraged the Western world to find explanations for the phenomena associated with older belief systems. The focus was on solving problems that society faced, with the intention of acquiring new knowledge that could provide answers and in turn result in science and medicine finding effective means to reverse the effects of illness or disease.

Although the development of body aids originated with the Romans, the craft of creating artificial prosthetics of brass, plaster and ceramic was not refined until the late 17<sup>th</sup> and early 18<sup>th</sup> century, when prosthetics were made in vast quantities to correct deformities in survivors of the numerous wars of the age. Assistive devices developed during the Victorian period are countless. Many assistive devices were improved: glass eyes, dentures, prosthetic limbs and artificial noses are a select few, and often show important inroads in design. The increasing need for such items and a thirst for change during the Victorian period accelerated medical development and knowledge considerably. Medical developments with broadly interpreted '*wearable*' or '*jewellery-like*' connotations of this period are evidenced in the metal orthopaedic corset, Fig. 10 of the Victorian era, designed to strengthen and correct withered or twisted spines. The force of the corset against the body provided support and gave the wearer confidence. Although the corset gave the wearer a voluptuous figure it would have been extremely heavy and uncomfortable to wear, and may have caused long-term damage rather than resolving the problem, but it provided instant results for those who wore it.



**Fig. 10**  
Metal Orthopaedic Corset  
After 1837  
England  
Brass

Wellcome Trust Collection,  
London (SM,A158256)



**Fig. 11**  
Collection of Fifty False Eyes  
1936  
Liverpool, England  
Possibly made by E. Muller

Wellcome Trust Collection, London



**Fig. 12**  
Coloured Lithograph  
The illustration depicts an elderly couple  
in the act of fitting their false teeth,  
artificial glass eye and wig.  
1825  
by F-S Delpech after L. Boilly, France.

Wellcome Trust Collection,  
London

Such technological advances relied upon technology and skills of the maker to enhance the wearer's life. Take for example the glass collection of eyes shown in Fig. 11. They demonstrate the '*improved craftsmanship*' and '*inclusive design approach*' of the Victorians to develop complex, realistic and comfortable prosthetics. More inherently functional items were being



produced during this period. Improvements in the design and build of prosthetics was an essential and practical assistance to many people and in many cases craftsmen used their best skills to create objects that would help to improve people's daily life<sup>2</sup>. A case in point which illustrates this are the prosthetic arms made by J. Gillingham Chard, Somerset (1839 – 1924), who was renowned for his shoemaking skills and who devoted his later working career to making prosthetic limbs<sup>3</sup>, eventually establishing a thriving business. The artificial left arm and hand (Fig. 13), showed the development of 19<sup>th</sup> century European made prosthetic arms, constructed with moving joints, elbows, fingers and even a sprung thumb for gripping.



**Fig. 13**  
Artificial Left Arm and Hand  
Dated around 1850-1910  
England  
Made from wood and leather and supported in position with leather sling-like straps and sprung thumb  
Wellcome Trust Collection, London



**Fig. 14**  
Body and Legs Brace  
Early 19<sup>th</sup> Century  
American  
Stanley B. Burns, MD & The Burns Archive N. Y.  
Science Photo Library, New York

<sup>2</sup> Telegraph (2006) *Chard was there first* [online], available from: <http://www.telegraph.co.uk/opinion/main.jhtml?xml=/opinion/2006/10/07/dl0703.xml> [Accessed June 2007]

<sup>3</sup>Arnold, K. & Olsen, D. eds. (2003) *Medicine Man, The Forgotten Museum of Henry Wellcome*, London: The British Museum Press, p. 340

In the 19<sup>th</sup> century many Victorian gentlemen owned walking canes and took pride in adorning themselves with an object which was slim, elegant, usually expensive and made from 'Malacca cane' often incorporating silver knob tops as they were rigid and sturdy, ideal for bearing weight and encouraging good posture, but also had the potential to be used as a weapon<sup>4</sup> to fend off thieves. Whilst in America during this period, a similar typical cane was valued as more of an orthopaedic aide. Doctors and surgeons used such desirable devices to conceal an array of medical implements and medicines<sup>5</sup>. 'The Doctors Cane 1890 - 1900' was one such example that was valued as a tool of necessity. It was designed to allow the top to be unscrewed to reveal a void in the centre of the shaft where a syringe, pills, needles, plungers and even a rolled up notepad and pen could be hidden away, or brass hearing trumpets could be mounted, thus allowing the doctor to incorporate the necessary implements required and highlight the different uses and at the same time combines jewellery design principles with medical usage. A decorative device with a utilitarian function concealed within the walking stick allowed the owner to personalise each cane.



**Fig. 15**

Doctor's Medical Cane  
About 1900-1950  
American  
L: 920mm  
Wooden Screw top with brass  
ridge, revealing inner  
compartment where one  
syringe and several pills can be  
placed, all contained within a  
partridge wood shaft.  
Private Collection

<sup>4</sup> Curtis, D. (1986) *The Walking Stick Has Place in History, Historic Treasure of the Week - May 4, 198, Vigo County Historical Society* [online] <http://web.indstate.edu/community/vchs/ht/ht050486.htm> [Accessed February 2008]

<sup>5</sup> McKittrick, R. (2007) *Gadget Canes at Top of Their Game at Tradewinds* [online] [http://www.liveauctiontalk.com/free\\_article\\_detail.php?article\\_id=699](http://www.liveauctiontalk.com/free_article_detail.php?article_id=699) [Accessed February 2008]



**Fig. 16**  
 Doctor's Medical Cane  
 About 1900-1950  
 American  
 L: 920mm  
 Silver screw top- revealing a  
 thermometer and protective  
 brass case, all contained within  
 a partridge wood shaft.  
 Possibly a replica.  
 Private Collection

Hearing-aids of the 19th century such as the 'Victorian hearing trumpet' would have also been perceived as a marvellous ornamental-device. They were commonly made from ferrous metals, tin or brass for maximum sound quality<sup>6</sup>, some of which were designed to retract like a periscope, making it possible to fit into small purses, pouches or pockets. They were used by all members of society and produced out of different materials in all shapes and sizes, to provide for personal preference. Such hearing tools were used in everyday life and not perceived as humiliating objects, and were regarded as more of an attractive and useful accessory (Figs. 15 and 16).



**Fig. 17 (with extract)**  
 Family Photograph (with detail) . 1880, England, John Murray  
 with eleven members of his family, by unknown photographer.  
 National Portrait Gallery, London. Archive Collection  
 (NPGx126860)

<sup>6</sup> Arnold, K. & Olsen, D. eds. (2003) *Medicine Man, The Forgotten Museum of Henry Wellcome*, London: The British Museum Press, pp 337 - 338



**Fig. 18**

Two Victorian Ear Trumpets  
19<sup>th</sup> Century  
England

One made from tin designed to retract making it possible to fit into small bags, purses and pouches. One made in black silk for mourning by Atkinson, Union Court, Holborn.

Wellcome Trust Collection, London



**Fig. 19**

Victorian Swan Shaped Ear-Trumpet  
Ear Piece  
Dated 1865  
England  
Silver with engraving  
by F C Rein and Son

Science Museum Picture Library, London  
Picture Library – Image no. 10284114

The cane and hearing aide trumpets show the development of fashionable objects, designed for a medical purpose but with the comfort and requirements of the specific user in mind. The non-collapsible trumpet is swathed in a fine black silk and laced for mourning, perhaps exclusively made for a wealthy widow. Both trumpets are functional in their purpose, yet deal with two distinctly different design-mechanistic approaches to show the item can be both carried and displayed. Other compact devices like the swan-shaped silver hearing aide trumpet were appreciated for their innovation, being both fashionably flamboyant yet pragmatic in design. The coloured engraving 'Living Made Easy: Revolving Hat', published by Thomas McLean, publisher of satirical prints which mocked fashions of the day, shows men wearing weird and wonderful hats designed to provide the wearer with eye-glass, cigar, scent-box, spectacles, hearing-trumpet etc without the need to carry them in a bag.

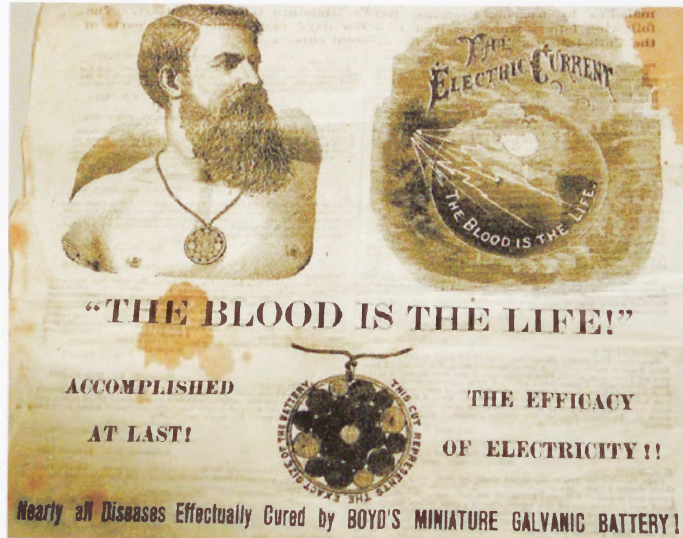

**Fig. 20**  
Revolving Hats Living Made Easy  
1830  
England  
Lithograph  
Published by T McLean, London

Science Museum Picture Library, London  
Picture Library – Image no. 10296563

In the mid to late 19<sup>th</sup> century many self-care devices were designed but only a few were taken seriously. One such item was the electric galvanic battery which was incorporated into the design of pendants and other items worn on the body, with the belief that they were beneficial to the wearer. It was not however until later in the Victorian period, that such devices became more sophisticated in their design and aesthetic form, such as the pendant promoted and made by J.C. Boyd's Miniature Galvanic Battery in 1879. This pendant with 18 small coin-like disks is made from various metals of which six were arranged in a circular pattern forming the central row. This row was then surrounded by the remaining twelve metal disks braced tightly together. Each disk was magnetically charged causing them to repel and attract their neighbouring disks. Boyd claimed within flyer advertisements that the humidity of the body and skin would cause the pendant to stimulate the body curing nearly all allergies, illnesses and

potential diseases<sup>7</sup>. This process allegedly produced ‘galvanic action’ that would balance out the body’s natural electrical energy.



**Fig. 21**  
Advertisement to promote the 'J.C. Boyd's Miniature Galvanic Battery Pendant'.  
1879  
American

The Journal of  
Design History  
Society, England

However these were shortly superseded by more advanced models such as the 'The Heidelberg Electric Belt' '*... the most wonderful relief and cure of all chronic and nervous diseases, all diseases, disorders and weaknesses peculiar to men, no matter from what cause or of how long standing!*' and *cure individuals with nervous dispositions*<sup>8</sup>. The invention of the Electric Belt was mainly due to commercial pressures to discover alternative medicines. The Electric Belt is one such device that would have utilised magnetized metals to create fields of electrical energy, supposedly to draw out pain. This form of 'electrical field therapy' had most likely originated from the therapy of metals and gemstones. For example, emeralds can allegedly stabilize one's 'aura', cleansing the body, whilst ferrous materials such as copper is said to aide in the recovery of stiff joints preventing one

<sup>7</sup>Thomas, D. L. Pena, C. (2001) Designing the electric body: Sexuality, Masculinity and the Electronic Belt in America 1880-1920', *Journal of Design History Society, England* Vol. 14, no .4, pp. 275-289

<sup>8</sup> Ibid, pp. 275-289

from suffering from arthritis in later life. There were those who disagreed with the plausibility of magnetic therapy, stating ‘...that it is no more than a scam<sup>9</sup>’.



**Fig. 22**  
Advertisement for ‘The Heidelberg Electric Belt’,  
1902  
American  
Sears, by makers Roebuck & Co.

The Journal of Design History Society,  
England

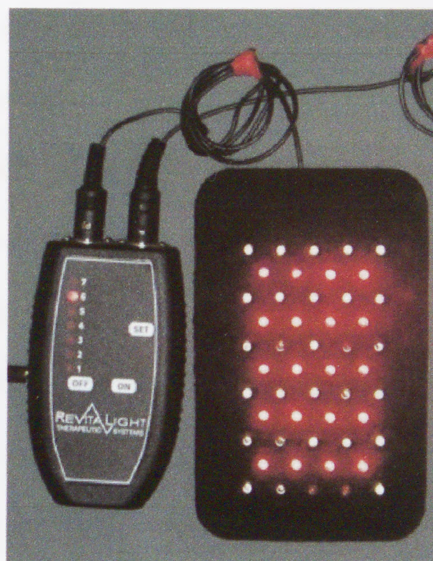

**Fig. 23**  
RevitaMed Infrared Therapy for  
Circulation Disorders  
1990  
Made by LymphaCare, New Jersey,  
America.

From online source: [www.emediawire.com](http://www.emediawire.com)  
[Accessed 20 September 2007]

Similar products are still being produced and manufactured within the 21<sup>st</sup> century: RevitaMed Infrared therapy (June 2006) was designed to be the most effective and inexpensive anodyne (pain relieving) infrared device to treat neuropathy and chronic pain. New Jersey based LymphaCare, already a national provider of home lymphedema products, is now offering RevitaMed Infrared Therapy as part of its product line for circulation disorders.

<sup>9</sup> Livingston, J. (1998) ‘Magnetic Therapy: Plausible Attraction?’ *Skeptical Inquirer*, Jul – Aug, pp. 25–30

To understand the development of jewellery, medicine and medical aides during this period, it is important to focus on specific material developments and attitudes. Many myths, legends and folklore remedies had been built up concerning metals and their medicinal properties, but whilst most are unsubstantiated some have an element of truth. Gold is a hygienic metal which helps ward off infection. Silver<sup>10</sup>, believed by many to improve psychic awareness, is used today by the medical profession, particularly in plasters and dressings, and has also been successfully applied within antibacterial solutions<sup>11</sup>, although it was abandoned as too costly for development in the early 1900's. Looking back on the artefacts of earlier centuries discussed in this chapter, it appears science and jewellery collaborated successfully then, unlike today. For example the goldsmith who made a pomander, amulet or magical jewel with medical properties would have worked together with an apothecary or a doctor. Today medicine is far removed from any objects of art and craft, and the jeweller of today does not include any scientific or medical element in design. Based on this historical study my project attempts to bring science and the craft back into productive co-operation.

To further understand the development of jewellery, medicine and medical aides during this period, it is important to focus on specific material developments and attitudes. Many myths, legends and folklore remedies had been built up concerning metals and their medicinal properties, but

---

<sup>10</sup> Silver Lon (2005) *Silver Wound Care and Burn Care Products* <http://www.silverlon.com/>  
[Accessed 27 May 2005]

<sup>11</sup> Becker, R. MD. (2005) *The Return of Silver in Medicine: Colloidal Silver Alternative to Antibiotics* [online], Health News line, available from: <http://www.quantumbalancing.com/>  
[Accessed 27 May 2005]



whilst most are unsubstantiated some have an element of truth. Gold is a hygienic metal which helps ward off infection. Silver<sup>12</sup>, believed by many to improve psychic awareness, is used today by the medical profession, particularly in plasters and dressings, and has also been successfully applied within antibacterial solutions<sup>13</sup>, although it was abandoned as too costly for development in the early 1900's. For example the goldsmith who made a pomander, amulet or magical jewel with medical properties would have worked together with an apothecary or a doctor. Today medicine is far removed from any objects of art and craft, and the jeweller of today does not include any scientific or medical element in design. Based on this historical study my project attempts to bring science and the craft back into harmony.

---

<sup>12</sup> Silver Lon (2005) *Silver Wound Care and Burn Care Products* <http://www.silverlon.com/>  
[Accessed 27 May 2005]

<sup>13</sup> Becker, R. MD. (2005) *The Return of Silver in Medicine: Colloidal Silver Alternative to Antibiotics* [online], Health News line, available from: <http://www.quantumbalancing.com/>  
[Accessed 27 May 2005]

## THE DIGITAL AGE

- Contemporary Medical Jewellery Projects -

Today, in the Western world, technology is used in digital devices including many medical appliances. It has influenced and changed the way we live and interact. It is also responsible for the success of many modern day innovations from light-weight personal computers for use at home to industrial life-support-machines used in hospitals. Portable medical devices such as pacemakers, glucose-meters and digital pulse sensitive watches, give us the ability to enhance, push and improve the body's physical capabilities in pursuit of sustaining a healthy quality of life whilst on the move.

*So, why is it important for jewellery makers to understand and use digital technologies?* Technology is largely perceived by craft makers as complex and unreliable. Jewellery makers of the past have applied technology sparingly, limited by the complexities of fabricating devices which can ultimately prove ineffective and unreliable, if used incorrectly. In truth, the more complex the technology becomes, the more likely it is to fail. However some makers such as Nicole Gratiot Stöber (1994), Shaun Leane (1996), Christoph Zellweger (1998), and Iran Sherman (2000) have integrated technology into their work, challenging the limitation of digital jewellery as a craft. This present research project is designed to further push the technical boundaries of a jewellery maker by developing complex interactive, touch-sensitive jewellery technologies.

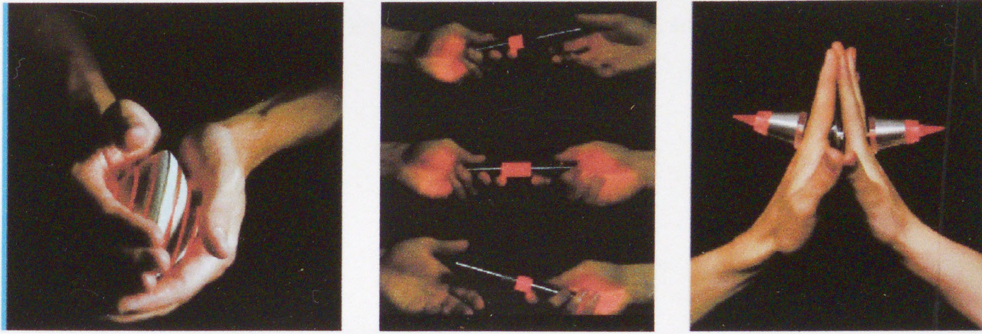

**Figs. 24, 25 and 26**

Objects by Nicole Gratiot Stöber

1994

England

Various working silver, ceramics, and plastics with inbuilt electronics

Private Collection

Most touch-sensitive devices today (like that shown in fig 27) use circuit-on-glass technology to convince receptors in the skin that the body is fluently interacting with a digital device. The main drawback of circuit-on-glass technology is tactility. The smooth glass is difficult to sense, and the act of touching a flat rectangular frame makes it intrinsically two-dimensional, which limits user interaction. Even electronic giants such as Apple, Phillips and Sony who currently dominate the digital device industry are restricted by this limitation, and as a result have not been able to convincingly develop digital jewellery. Furthermore, ergonomics tells us that circuit-on-glass technology can be used by most people, but the tactile technology excludes many with physical disabilities such as sight impairment and those with dyspraxia (limited hand and eye coordination). The small screen demands nimble finger work to accurately control the interactive elements as the user can easily push too many sensors at one time. People with large hands or those who suffer from arthritis in the hands or fingers will find the action painful and frustrating. They would not have the ability to navigate even the simplest of menu functions making it hard to

manage in daily situations, thus rendering the device useless in the event of an emergency.



**Fig. 27**

Sony N1 touch menu 350  
2006  
England

From online source:  
[www.sony.co.uk](http://www.sony.co.uk)  
[Accessed March 2007]

Most attempts to develop digital jewellery are not for medicinal gain but for commercial profit. For instance, in 2007, eleven electronic companies including Phillips Electronics<sup>14</sup> took part in a project known as STELLA<sup>15</sup> to develop stretchable mood-sensory technology designed to be worn against the skin like jewellery.

---

<sup>14</sup> Netherlands BV, Freudenberg Forschungsdienste KG, Interuniversitair Micro-Electroinca Centrum VZW, Technische Universitat Berlin, Commissariat a L'Energie Atomique, QPI Quality Products Int BV, BE Semi Conductor Industries NV, Verhaert New Products & Services, Laboratoires Urgo, Fundico bvba, Phillips Innovative Technology Solutions. From <http://www.stella-project.de/> [Accessed November 2007]

<sup>15</sup> STELLA abbreviation of STreachable ELelectronics for Large area Applications [online] <http://www.stella-project.de/> [Accessed November 2007]

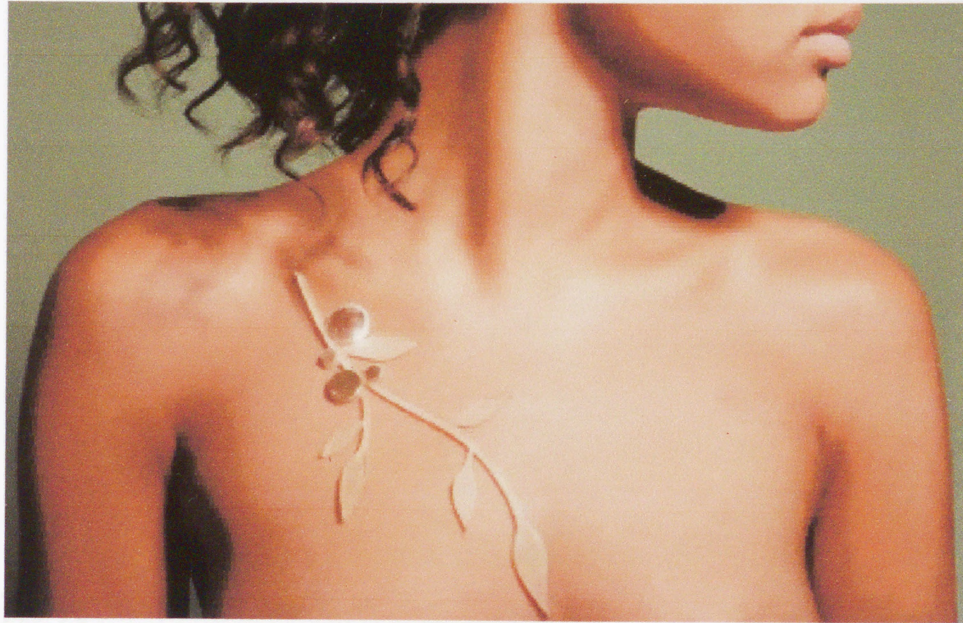

**Fig. 28**

Skin-Tile Jewellery Prototype

2007

German

STELLA Project - Developed by 11 electronic giants including PHILIPS. The jewellery is programmed to reflect the wearer's mood

From online source: [www.shinyshiny.tv/2007/10/skintile\\_skin\\_j.html](http://www.shinyshiny.tv/2007/10/skintile_skin_j.html)  
[Accessed November 2007]

The technology employs the use of opaque flexible substrates similar to those found in many medical products, which are designed to respond to the wearer's mood by changing colour when exposed to fluctuating skin temperatures. Such projects show how companies are prepared to collaborate in order to explore new possibilities, including jewellery applications. Only a few years earlier in 2005 a group of Royal College of Art graduates and bio-engineers from Guys Hospital, London teamed up to take part in an experiment that took bio-engineering processes to a new level. It focused on lab-growing human bone material to form rings intended for use as wedding jewellery.



**Fig. 29**

Bone Wedding Ring

January 23rd, 2007

London, England

Bio-jewellery was a collaboration between Tobie Kerridge,  
Nikki Stott and Ian Thompson, and was funded by the EPSRC

From online source: <http://www.coolbusinessideas.com>

[Accessed January 2007]

I believe that today's consumer is not quite ready to embrace or implement such technology. Ethically, the unfamiliarity of collecting, harvesting, and growing bio-matter to form a new type of modern jewellery might be a step too far for the general public to embrace as a symbol of marriage today. However impractical to mass produce, due to the slow growing process, the idea is provocative and demonstrates creative thinking. It is also unique in its collaborative approach, where the jeweller, product designer and bio-engineer strive equally in pursuit of realising a final outcome, whilst pushing the boundaries of contemporary jewellery.

There are other interesting conceptual designers like Leah Heiss<sup>16</sup> who in 2007 began to use jewellery as a means of improving the look and feel of identification products, like the medic-alert ring shown in fig. 30.



**Fig. 30**

Interchangeable Medic Alert Ring  
2007

Australia

Designed by Leah Heiss

Project supported by The Australian Network  
for Art and Technology and Nanotechnology Victoria

From online source: <http://www.tuvie.com/diabetes-and-arsenic-jewelry-by-leah-heiss>  
[Accessed April 2009]

The interchangeable Medic-Alert ring demonstrates how jewellery could be used to discretely hide a patient's medical details. On a critical level, the designers' decision to omit the medical 'caduceus symbol'<sup>17</sup> as a main feature of the jewellery could, in part, compromise its purpose as medic-alert identification jewellery. In an interview I conducted in 2005 with Niamh Murphy Head of Communication and Education at the Medic Alert

---

<sup>16</sup> Leah, in 2008 has gained support by The Australian Network for Art and Technology and Nanotechnology Victoria to collaborate in the development of a pain free insulin delivery system using their micro-needle technologies.

<sup>17</sup> The Caduceus is the name given the universal medical symbol depicting a staff entwined with two serpents. All Medic-Alert identification jewellery are engraved with this symbol, some on a vivid red backgrounds.

Foundation she stated: "...the emblem should be engraved on a metal based disk, making it legible and hard wearing. They would always have the international Medic-Alert symbol on the front of the disk and the words 'MEDIC ALERT'." I believe that many conceptual designers are lured into the trap of valuing aesthetics above function, removing important information, and in doing so produce a product that could give misguided confidence to the wearer. However, there are some designers that have integrated jewellery characteristics with a more balanced approach. Take for instance, the customisable Diamond Braille dotted ring made by the designer Stephen Einhorn or the diamond encrusted digital hearing aid by the company Widex.



**Fig. 31**  
Diamond Braille Dotted Ring  
2007  
London, England  
Designed by Stephen Einhorn

From online source:  
<http://www.letstalkjewellery.co.uk/2007/06/26/diamond-braille-dotted-ring/> [Accessed November 2007]



**Fig. 32**  
Gold and Diamond Digital Hearing Aid  
2008  
Denmark  
Widex  
cast in solid 24-carat gold and encrusted  
with 220 diamonds, retail value £25,000.

From online source:  
[http://sc.widex.com/?sc\\_lang=en](http://sc.widex.com/?sc_lang=en) [Accessed March 2008]

Both the diamond ring and the gold hearing aid demonstrate how pharmaceutical companies and independent designers are using jewellery to improve or enhance already existing technologies. I believe that true



creative thinking balances aesthetics with function. Medical products made today can be pushed further by applying skills and philosophies of craft along with those of medicine and engineering in pursuit of developing a more realistic and user friendly medical jewellery product. Here, as part of this research I attempt to develop new jewellery technologies that show an in-depth understanding of the patients' condition, whilst demonstrating a sympathetic approach to their needs. All along, my objective has been to develop medical jewellery that does not compromise function and performance. The developments made have been achieved using technologies of today and are not conceptually based fantasies of the future.

## A LOOK TO THE FUTURE

*-The Path to Digital Jewellery -*

As we move into a new digital age, men, women and children look to the future for technology to serve, protect and safeguard the body in times of need. Although, it is generally through science that society seeks medical advances, artefacts and jewels of the past have played their part in serving to ameliorate and cure many human conditions. Evidence shows that from medieval times jewellery has been used for many different reasons: to decorate the body, to express one's political or social position, and also though less known, as a carrier of medication (see Appendix A for more details).

This chapter (accompanied by Appendix F) has show that civilisations have used healing jewellery to prevent illness and even death by carrying vital medicines. This arguably gave many people the courage to face adversity in desperate times. Controversially, the evidence shown in this chapter proves that jewellery today has, in recent years, lost many of its medical associations. If society refuses to consider such philosophies of jewellery as having serious potential influence in medicine, then our reliance on science to solve all problems may continue and create a hyper-sensitive society.

It is therefore important to ensure that the historical artefacts are not overlooked or rejected. In fact, the new pomander in skull form, shown on the following fig, demonstrates how old medical jewellery artefacts could be brought up-to-date to carry new manufactured medicines.



Sometimes, where science can fail, the diversity of alternative medical objects can succeed, as clearly demonstrated by the success of the amulet with its non-aggressive application or placebo effect, perhaps being perceived to be more sympathetic to the needs of the consumer, although somewhat constrained by cultural boundaries.

## CONSULTATION WITH TABPI

- Trade Association for the British Pharmaceutical Industry -

In a phone consultation with Dr Richard Tyler, Medical Director for the Trade Association for the British Pharmaceutical Industry (6<sup>th</sup> August 2006), he commented on the importance of providing services to the pharmaceutical Industry and the National Health Service. I asked Dr Tyler if his patients' experienced difficulties in misusing their medicines as a result of poor packaging. He stated that this was: "*...one area we would like to improve.*" The conversation then diverted to the topic of funding. I questioned Dr Tyler about the 3.5 billion pound yearly allocation for developing new medicines, asking how much was allocated to packaging? He explained: "*The money is put into research and development of the medicine, not packaging...There is a negotiated pricing structure for all prescription medicines in the UK called the Pharmaceutical Price Regulatory Scheme and it is negotiated on a 5 yearly basis... the ...individual cost of a medication is determined by the company, but they have to work within a profit range that are governed by negotiations.*". This negotiation process inevitably causes difficulties when developing devices to carry them. If the medicine costs more in one area of the UK than in another then the device must inevitably reflect these differing costs.

The challenge for me was not just in developing medical jewellery but in producing a device which also reflects the fluctuating market over time. The jewellery must be able to accommodate new medications as they evolve but also be sympathetic to changes in the sale of medication. The jewellery product should be appropriately priced and manufactured to a high quality to comply with the National Institute of Clinical Excellence regulations and Pharmaceutical Price Regulatory Scheme.

This research is intended to address some of these economic issues by demonstrating an alternative machining and handcrafting process that could be used to build more complex Printed-Circuit-Structures (PCSs) and electrically conductive patterns for use in medical jewellery. If these manufacturing processes were to be applied by Phillips or Sony they may alleviate a number of physical constraints and allow for an infinite array of new ideas or future possibilities for the jewellery industry.

# CHAPTER 2

## BABY-BLUE GSR MODULE

<b>THE FUTURE OF JEWELLERY AND MEDICINE</b> <i>Personal Jewellery to Ease Social Tensions of Disability</i>	63
<b>TOUCH SENSITIVE JEWELLERY</b> <i>Development of Touch Sensitive Digital Jewellery for use in Medical Applications.</i>	65
<b>BABY-BLUE TECHNOLOGY</b> <i>Development and Testing of Body Acquisition Bio-Sensory Jewellery with Integrated BLUE-Tooth Technology</i>	66
<b>THE BABY-BLUE GSR CIRCUIT</b> <i>Development of the BABY-BLUE Galvanic Skin Response Module</i>	68
<b>PROGRAMMING THE BABY-BLUE GSR MODULE</b> <i>Programming Bio-Sensory Jewellery</i>	79
<b>INTEGRATING BLUE-TOOTH TECHNOLOGY</b> <i>Considerations on Integrating BLUE-Tooth Technology</i>	93
<b>BABY-BLUE TEST TRIALS</b> <i>Problem Solving</i>	97
<b>CONDUCTIVE CIRCUIT IMAGERY</b> <i>The Development of Rigid and Flexible Circuits for use in Jewellery Applications</i>	103
<b>RE-DESIGNING THE BABY-BLUE CIRCUIT BOARD</b> <i>Developing Flat and Flexible Circuit Boards for Use as Part of the BABY-BLUE GSR Module</i>	104

## THE FUTURE OF JEWELLERY AND MEDICINE

- Personal Jewellery to Ease Social Tensions of Disability-

Society as a whole is often unaware of the medical conditions that many people are dealing with on a daily basis, despite the fact that everyone at some point will be faced with a disability of some kind or another. I believe that by concealing human defects like disabilities, we are establishing a society<sup>18</sup> which is self-conscious or embarrassed about differences that in part make us uniquely individual<sup>19</sup>. At worst, these issues can potentially manifest themselves within an individual as self-loathing or forms of depression<sup>20</sup>. Furthermore, this is not helped in many cases by the patient having to rely on such impersonal devices as medically assistive aides<sup>21</sup>. My aim is to provide the consumer with fully functional yet desirable devices and offer credible alternatives that challenge existing self-care products<sup>22</sup>. This chapter shows the key procedural requirements for the design and construction of jewellery for medicinal use. All developments (including the universal card-charger) are explained here, focusing specifically on the technical difficulties and creative aspects of inventing digital jewellery technologies. This section offers fellow researchers the opportunity to review or replicate the inventions I have developed.

---

18 Fisher, S. & Cleverland, S. E. (1958) *Body Image and Personality*, New York: Dover Publications

19 Mulley, G. P. DM FRCP (1989) *Artificial Limbs, Everyday aids and appliances*, London: British Medical Journal, pp. 1 - 22

20 Metro. (2004) *The Guide to Healthy Living in Your Area: NHS Approved! - Supplement*, Metro, 09 September, pp. 1-8.

21 Southgates T. N. & Cochrane G. M. (1987) *Equipment for disabilities*, London: Oxfordshire Health Authority, Cotswold Press

<sup>22</sup> Slater, D. (1997) *The Culture of Commodities, Consumer Culture & Modernity*, Cambridge: Policy Press

## RESEARCH DISCLAIMER

Developing the embedded technologies, structured arrays and algorithmic formulae that will get good results out of design prototypes requires considerable knowledge in engineering, electronics and computer languages. Most of the coding has been omitted from this report for legal reasons. The following images, text, diagrams and coding shown as part of this research is the rightful property of Leon B M Williams, Centre for Jewellery Research, Department of Goldsmithing, Silversmithing, Metalwork and Jewellery unless stated otherwise.



## TOUCH SENSITIVE JEWELLERY

*-Development of Touch Sensitive Digital Jewellery for Use in Medical Applications -*

Touch is arguably the most valuable human sense<sup>23</sup>. It is understood to be the first sense we experience in the womb and the last one we experience before death. Science tells us that there are more than 5 million sensory cell receptors located beneath the surface of our skin of which 100 line each fingertip, making them highly sensitive to pressure, heat, pain, and humidity<sup>24</sup>. It is no surprise that our hands alone can distinguish very small variations in surface textures and material qualities. For instance, the feeling of pure silk between the fingers differs enormously from the sensation of the warmth of precious gold when held in the palm. *So, how does this apply to new technology?* As technology makes possible ever smaller devices and demand for digital-devices increases, there are important opportunities to refine touch sensitive technology suitable for use in jewellery. The benefits are endless. If a technique could be developed and used it could change the way jewellery is recognised and made by the craftsmen of today for the manufacture of the future: a jeweller could apply such knowledge to the development of interactive digital jewellery or alternatively to develop new touch sensory jewellery capable of monitoring various body parameters - as this research sets out to demonstrate.

---

<sup>23</sup> Objective sense of which expert believe there are between 14 and 20 currently debated

<sup>24</sup> The dermis is a layer of skin beneath located below epidermis that consists of connective tissue partly made up of about 100 nerve ending that provide the sense of touch, pressure and heat. More information can be found at <http://library.thinkquest.org>

## BABY-BLUE TECHNOLOGY

*-Development and Testing Body Acquisition Bio-sensory Jewellery  
with Integrated BLUE-Tooth Technology-*

In pursuit of better patient care, physicians today need to monitor more than one medical parameter of a patient. This is particularly important for those who need to adhere to tight drug regimes whilst at home or work. Patients with diabetes, asthma or HIV would benefit enormously from a single device or a set of devices that are easy to wear and reliable in collecting data about their body, condition or medication. Such devices would give patients the responsibility to wear such jewellery to better manage their condition at work or at home. Furthermore, a patient's physician would benefit from the recording of accumulative data, sharing confidence that a more thorough analysis of the patient's condition and lifestyle are considered.

This chapter outlines necessary development procedures for the fabrication of a single non-invasive galvanic skin response (GSR) module. The module invented here is one of a series developed for the detection of different body parameters, such as pulse oximetry<sup>25</sup>, skin humidity, skin conductivity, and pressure sensitivity.

---

<sup>25</sup> Oximetry is the process used for measuring the amount of oxygen in the blood

There are many direct benefits of implementing Body Acquisition Bio-sensory Technology. *Why bring 'jewellery' into the equation?* The interaction of medicine and jewellery combines the practical implications of both disciplines, creating a product which offers the user better control over function, application and aesthetics. There are a number of methodical approaches involved in the building of such devices. This research focuses only on the most important aspects of the device build, paying particular attention to problem-solving various technical difficulties and the realisation refinement of key interactive qualities that would make such jewellery convincing as a medicinal aide and not simply as a commodity worn primarily for pleasure.

## THE BABY-BLUE GSR CIRCUIT

*-Development of the BABY-BLUE Galvanic Skin Response Module-*

The BABY-BLUE circuit project involves the development of three different types of modules to be worn on the body: those that sense the body or environment; those that sense the active state of the jewellery, and finally those that receive and use data. When used together a fully operational system is made, where the patient is able to relay information from and to different BABY-BLUE technologies.

For the purpose of designing digital jewellery, the most logical approach was to separate the different sensor technologies into individual modules, making them interchangeable. By this means the end user would be given control over which body parameter was being monitored, and when. In this case, by monitoring the galvanic skin response on a daily basis, a patient is empowered by the ability to monitor the humidity of the skin over the course of a day, week or month with the intent to use it as a learning aide, to modify specific aspects of their daily life or medication, to improve their quality of life overall. Each module is programmed to read a set number of patient parameters, remotely managing and monitoring the body in real-time. The modules are designed to interact with one another through wireless communication protocols.

The patient would also have the ability whilst on prescribed medicines, to see in real time on a graphical display or laptop their personal results and so detect bodily stresses as they occur.

The first requirement of the BABY-BLUE project was to assemble a working prototype circuit. The 8-bit 18F2480 programmable interrupt controller (PIC) was selected for its compact package size and on-board peripherals, such as 16 kilobytes of programmable flash memory for data storage. The following schematic diagram shows the first generation Body Acquisition Bio-sensor designed with an external clock oscillator. The schematic diagram shown in Fig.35 was made using software known as 'Schema'. An online gEDA open source programme designed for use with the Linux operating system:

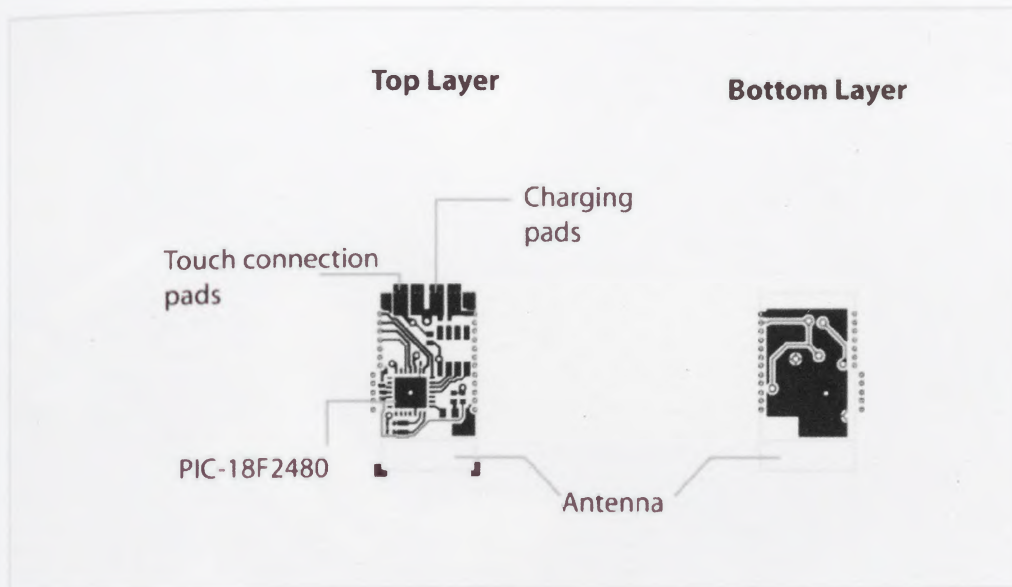



**Fig. 36**  
First Generation BABY-BLUE GSR module,  
2005  
© Leon B M Williams

Shadow Robotics, London  
Royal College of Art, London

Improvements were later made in the second generation circuit as shown in Fig. 37. These included performance of the module overall and reduction in package size and footprint. A fully calibrated digital SH15 humidity and temperature sensor from Sensirion© was used to deliver more accurate readings. Space on the circuit board could be kept to a minimum. One consideration was to redesign the footprint of the printed wiring board to prevent any components from infringing, blocking or masking the antenna when the separate modules were placed back to back.



**Fig. 37**  
 Second Generation BABY-BLUE Board Design Layout,  
 2005  
 © Leon B M Williams

Shadow Robotics, London  
 Royal College of Art, London

The rectangular circuit design shown in Fig. 38 mirrored the T9JRN41-1 BLUE-Tooth module to ensure a tight fit when they were soldered together at a later stage. The BABY-BLUE GSR was developed to reduce the possibility of signal interference caused by components on the circuit being mounted too close to the antenna. This problem was resolved by repositioning the vital components at different ends of the module to improve the overall performance.

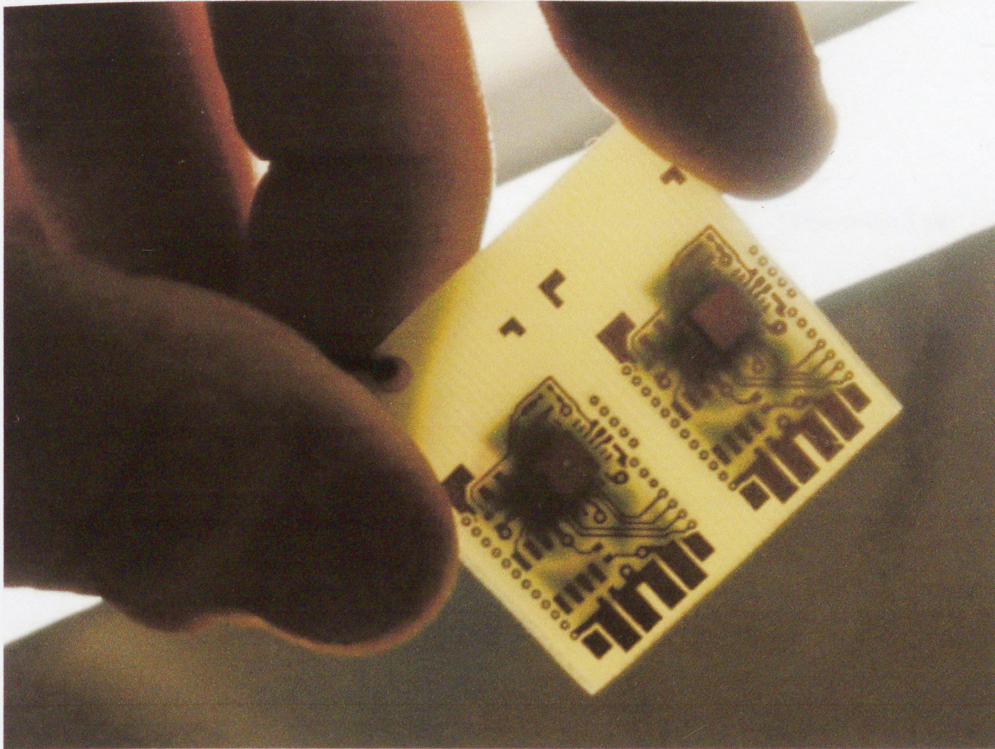



**Fig. 38**  
Hand Crafting the BABY-BLUE GSR Module,  
2006  
© Leon B M Williams

Shadow Robotics, London  
Royal College of Art, London

After assembling the components, a series of lab tests revealed that major improvements were achieved in sensor performance, as the mounted components did not physically interfere with or restrict one another – a circumstance which in previous versions prevented the device from functioning. The circuit proved successful as a galvanic skin response module. Wireless communication, however, was not implemented.

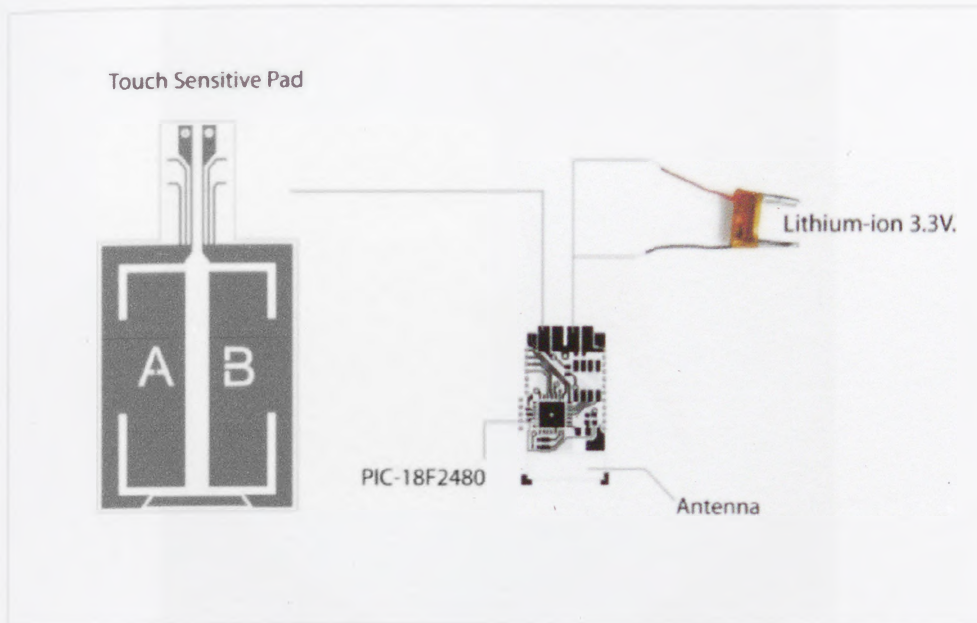

**Fig. 39**

Third Generation BABY-BLUE GSR  
Module Design,  
2006  
© Leon B M Williams

Shadow Robotic, London  
Royal College of Art, London

The third generation BABY-BLUE circuit was built with the aim to conserve power. One option was to programme a module to turn on and off at different times of the day, causing the sensor to activate and store parameter readings within the PICs onboard flash memory ready for transmission. When the patient touches particular parts of the circuit, data will be streamed to any nearby BLUE-tooth device or personal computer. The drawback of this option was that the user would be restricted to tapping the device only when they required an up-to-date reading, at set times.



**Fig. 40**

Third Generation BABY-BLUE GSR Module  
with Lithium-ion 3.3v and Touch Sensitive Pad  
2006

© Leon B M Williams

Centre for Jewellery Research,  
Royal College of Art, London

A more successful option was to programme the circuit to maintain a consistent low voltage (sleep mode) until a specific area on the board was touched, or an unusual reading was recorded. The main drawback was that the circuit would continuously draw power, with the consequence that if the lithium battery were to drop too low, the circuit would cease to function without the wearer being aware of the state.

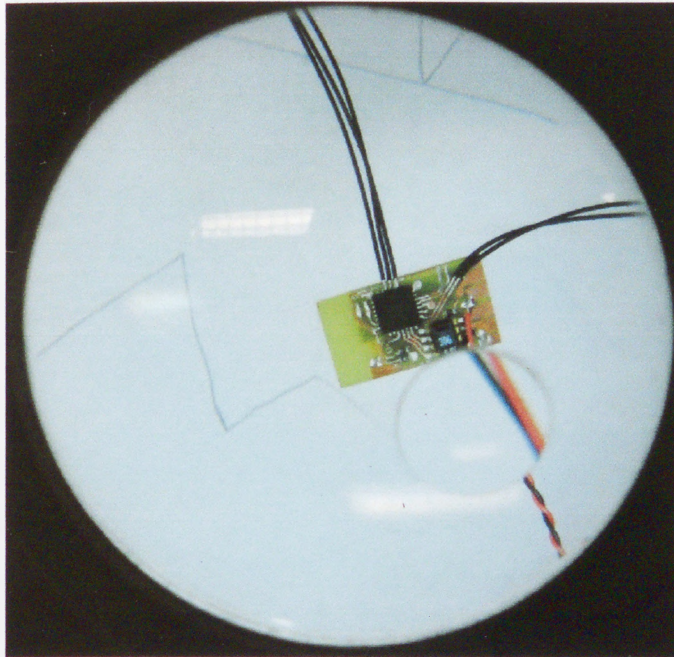
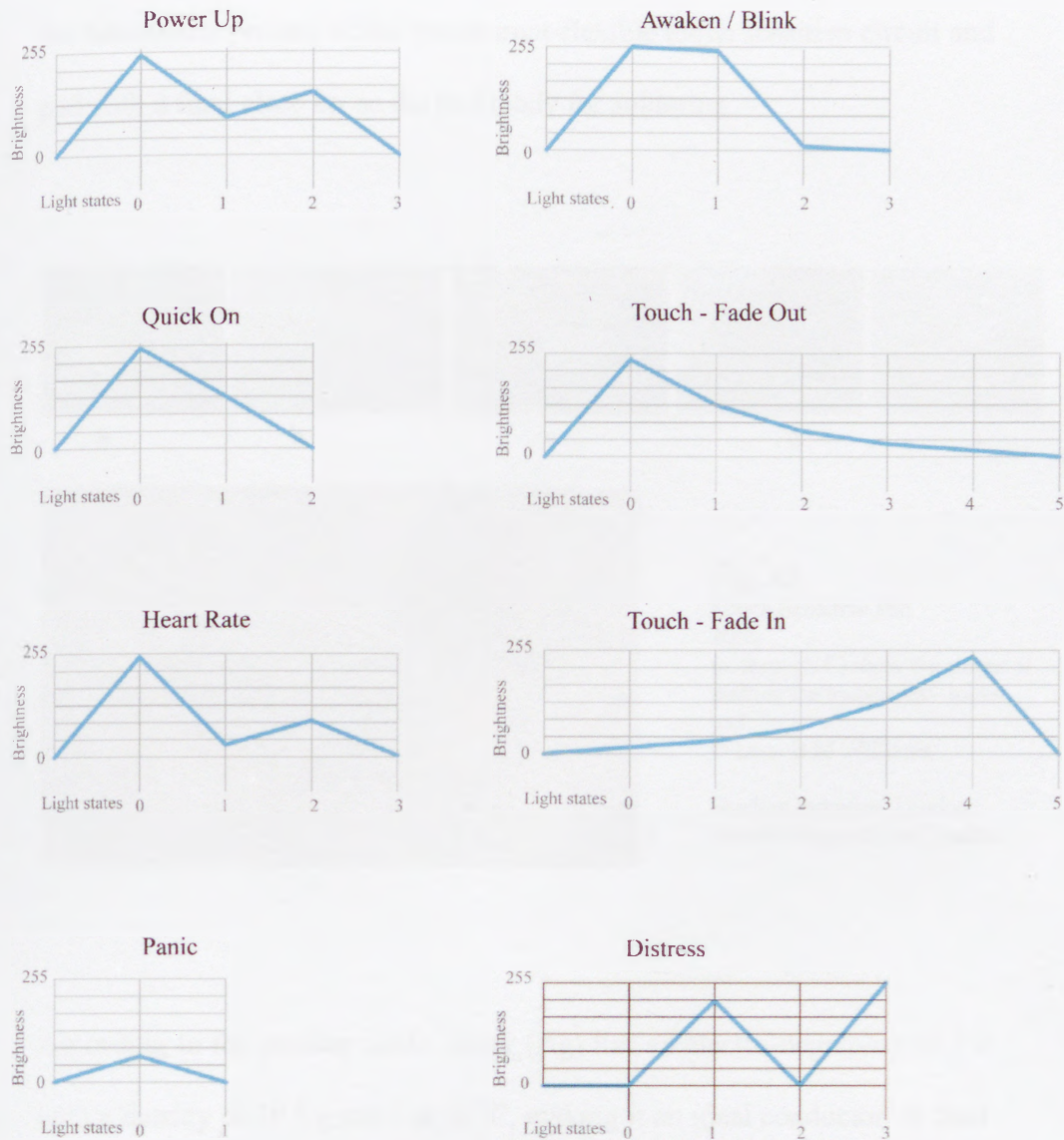

**Fig. 41**  
Assembling the Module (under magnification)  
2006  
© Leon B M Williams

Shadow Robotics, London  
Royal College of Art, London

In this case, one solution was to implement a programme sequence of light pulses indicating to the wearer that the circuit required charging or mechanical assistance – forming the basis for a bi-directional dependency between the wearer and the module. When worn, it could notify the wearer of any unusual activity through short pulses from the light-emitting diode. For instance the act of picking up the circuit for the very first time in the day would deliver a set rhythmical display of pulsing light, indicating that the device has been touched and is in good working order. This brief blinking phase would indicate when the sensor is ON and active.

## EIGHT BASIC LIGHT EMITTING DIODE RESPONSE RHYTHMS FOR THE BABY-BLUE GSR MODULE



The brightness of a single light emitting diode is represented by a figure between 0 and 255 (255 being the brightest). The time in which the light is made brighter or dimmer is shown by the beep blue line over a set number of states. The more states present is indicative of the number of changes in light sequence. By controlling both the brightness and sequence different rhythms of light can be performed.

**Fig. 42**

Eight Basic Light Emitting Diode Response Rhythms for the BABY-BLUE GSR Module

2006

© Leon B M Williams

Centre for Jewellery Research,  
Royal College of Art, London

A touch sensitive pad measuring 13 x 26 x 0.4 mm was developed as shown in Fig. 43, to temporarily represent a jewellery form which was to be developed at a later stage in the project. Images a. through to e. describe the fabrication process of the transparent-flexible touch sensitive circuit and pad with a final close up on the pad ready for soldering.

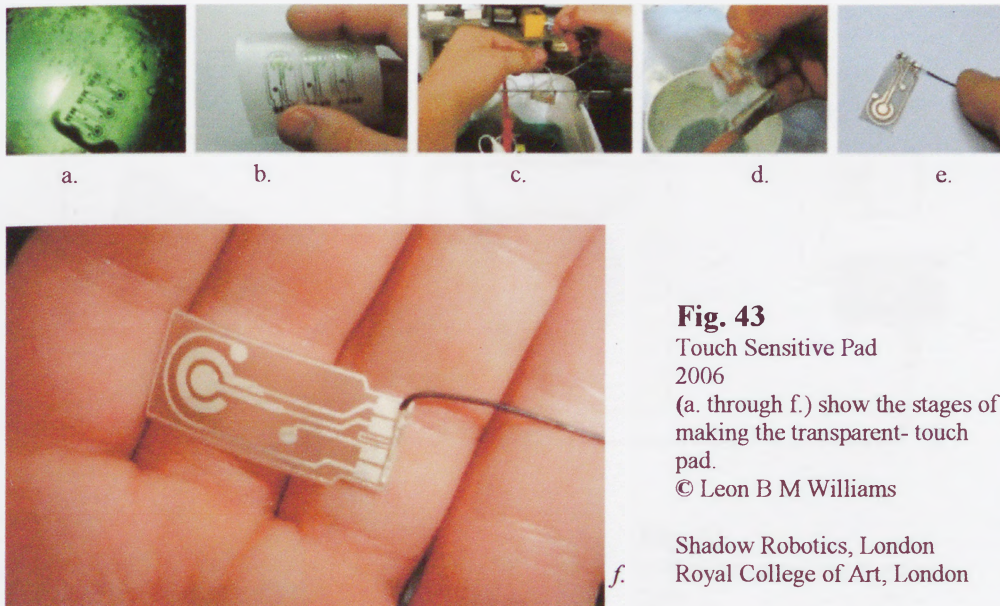

**Fig. 43**

Touch Sensitive Pad  
2006

(a. through f.) show the stages of making the transparent- touch pad.

© Leon B M Williams

Shadow Robotics, London  
Royal College of Art, London

According to the *pauling scale*, silver (Ag) has an electro-negativity of 1.9 with a density of 10.5 g.cm<sup>-3</sup> at 20°C, making it an ideal conductor. A final silver electroplating process was performed on the touch pad to prevent oxidation forming on the wire pattern and to improve its conductive properties. This allowed for selective parts of the pad to form more substantial conductors on the exposed surface. When combined, the BABY-BLUE module and touch pad activates the sensor, triggering wireless communication protocols through the act of touching.

## PROGRAMMING THE BABY-BLUE GSR MODULE

*-Programming Bio-Sensory Jewellery-*

The following code blocks were designed for the 18F2480 programmable interrupt controller (PIC). To clarify, the C code was written in MPLAB and later converted to Visual Studio to show the workflow and syntax.

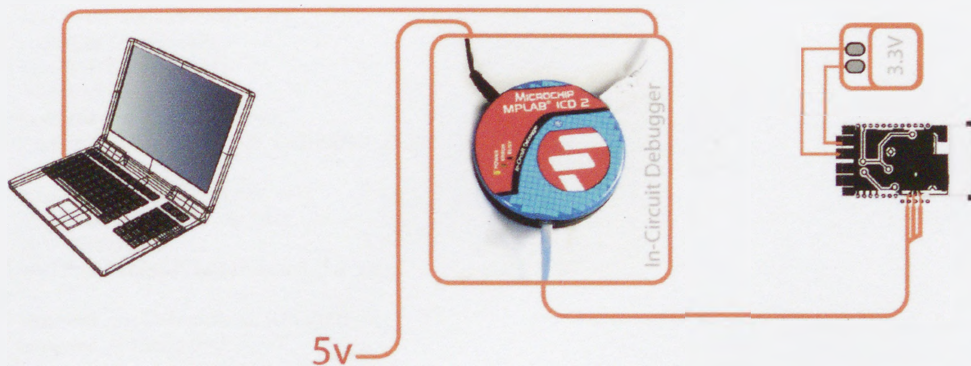

**Fig. 44**

© PCB Programming Pipeline  
2006

Showing the laptop, in circuit  
debugger and BABY-BLUE GSR  
Module

© Leon B M Williams

Royal College of Art, London

The following header files were included in the project, although the `<p18f2480.h>` was needed:

```
/* Compile options: -ml (Large code model) */
```

```
#include <p18f2480.h>  
//#include "basics.h"  
//#include "Mcp320x.h"  
//#include "Spi.h"  
//#include "stepper.h"  
//#include "Ad8556.h"
```

Pragma code blocks were later added for a clear workflow.

```
#pragma code

void SetupPorts(void);
void Setup_UART(void);
void SendCharUART(char c);
void SetupTimer1(void);
void WaitTimer1(void);
void SetupPWM(void);
void LED_PWM(unsigned char brightness);

void SetupHumidity(void);
void ReadHumidity(void);
void ReadTemperature(void);
void SetupLEDPatterns(void);
void HumidityRead12BitValue(void);

void Setup_TouchSensor(void);
void Read_TouchSensor(void);
void WaitTouch(void);
void WaitTouch2(void);
void WaitTouch3(void);
unsigned char touchSensor=0;
#define TOUCH_SENSOR_THRESHOLD 32

void PrintHex(unsigned char val);
void Print(const rom char *str);
void PrintTime(void);
void PrintDecimalChar(unsigned char val);

unsigned char HResultL=0, HResultH=0;
unsigned int HResult=0;

typedef struct t_LEDPattern
{
    unsigned char levels[6];
    signed char rates[6];
    unsigned char numStates;
}LEDPattern;
```

The next stage was to define a set of commands for the light-emitted diode.

Here I demonstrate one method of defining a simple set of light response rhythms to indicate the different states.

```
#define LEDS_ON 0
#define LEDS_ON2 1
#define LEDS_OFF 2
#define LEDS_HEART_BEAT 3
#define LEDS_PANIC 4
#define LEDS_BLINK 5
#define LEDS_FADE_OUT 6
#define LEDS_FADE_IN 7
#define LEDS_DISTRESS 8
```



More complex human touch response patterns were then defined. They allowed for the module to identify the difference between a smack, press or a subtle stroke. Later these more complex touch responses were used to develop basic behaviours, allowing the module to identify when the wearer is in a state of panic.

```
#define NUM_LED_PATTERNS 9
LEDPattern ledPatterns[NUM_LED_PATTERNS];
unsigned char currentLEDPattern=LEDS_ON2;
unsigned char currentLEDState=0;

#define SMACK_MIN 10
#define SMACK_MAX 50

#define PRESS_MIN 10
#define PRESS_MAX 75

#define STROKE_MIN 40
#define STROKE_MAX 90
```

Declarations, parameters, statements and definitions were then added.

```
typedef struct t_TouchPattern
{
    unsigned char max[6];
    unsigned char min[6];
    unsigned char numPulses;
    unsigned char progress;
}TouchPattern;

#define NUM_TOUCH_PATTERNS 3
TouchPattern TouchPatterns[NUM_TOUCH_PATTERNS];

void TouchPatternIdentified(unsigned char pattern);
void UpdateTouchPatterns(unsigned char pulseLength);
void SetupTouchPatterns(void);

unsigned char centiSeconds=0, seconds=0, minutes=0, hours=0, touchTimer=0;
unsigned char timeChar;
unsigned char timeString[10] = "01:02:03";

void CheckUART(void);
void CheckTimer1(void);
void SetTimeFromTimeString(void);
void UpdateTime(void);
```

The next stage was to design the *Main* executable programme functions.

```
void main (void)
{
    int i,j, k;
    unsigned char brightness=0, d=0, state=0, exiting=0;
```

```

SetTimeFromTimeString();

SetupPorts();
Setup_UART();
SetupPWM();
SetupHumidity();
SetupLEDPatterns();
SetupTouchPatterns();

OSCCON = 0b01110010;

Setup_TouchSensor();
Read_TouchSensor();
SetupTimer1();
Read_TouchSensor();

LED_PWM(255);
Read_TouchSensor();

PrintTime();

while(1)
{
WaitTouch();
exiting=0;
currentLEDPattern=LEDS_ON2;
currentLEDState=0;

SendCharUART("\n");
PrintTime();
SendCharUART("\n");
ReadHumidity();
Print("Humid = ");
PrintHex(HResultH);
PrintHex(HResultL);
SendCharUART("\n");
ReadTemperature();
Print("Temp = ");
PrintHex(HResultH);
PrintHex(HResultL);
SendCharUART("\n");

while (!exiting)
{
for (i=0; i<155; i++)
for (j=0; j<25; j++)
k++;

brightness += ledPatterns[currentLEDPattern].rates[currentLEDState];
if (brightness == ledPatterns[currentLEDPattern].levels[currentLEDState])
{
currentLEDState++;
if (currentLEDState >= ledPatterns[currentLEDPattern].numStates)
{
currentLEDState=0;
exiting=1;
}
}

LED_PWM(255-brightness);

};
};
}

void SetupPorts(void)
{
char i;

```

```

ADCON1 = 0b00001111;
ADCON0 = 0b00100100;    // AD con disabled for now ...

TRISA = 0b11111111;
TRISB = 0b11111111;
TRISC = 0b11110000;

CCP1CON = 0x00;
}

void Setup_UART(void)
{
    TRISC |= 0b10000000;
    TRISC &= 0b10111111;

    SPBRGH = 0;
    //SPBRG = 64;           // 9600 baud, when Fosc = 8MHz
    SPBRG = 16;           // 115200 baud, when Fosc = 8MHz

    TXSTA = 0b10100110;
    RCSTA = 0b10010000;
    BAUDCON = 0b01001000;
}

void Setup_TouchSensor(void)
{
    ADCON2 = 0b00100101;
    ADCON1 = 0b00001101;
    ADCON0 = 0b00000101;
}

void Read_TouchSensor(void)
{
    ADCON0 = 0b00000111;
    while (ADCON0 & 0x02)
    {};
    touchSensor = ADRESH;
}

void WaitTouch(void)
{
    touchSensor=0;
    while (touchSensor < TOUCH_SENSOR_THRESHOLD)
    {
        CheckUART();
        CheckTimer1();
        Read_TouchSensor();
        // if (seconds&1)
        //     LED_PWM(255);
        // else
        //     LED_PWM(0);
    };
}

void WaitTouch2(void)
{
    touchSensor = 0;

    LED_PWM(255);

    while (touchSensor < TOUCH_SENSOR_THRESHOLD+10)
    {
        CheckUART();
        CheckTimer1();
        Read_TouchSensor();
    };

    touchTimer = 0;

    while (touchSensor >= TOUCH_SENSOR_THRESHOLD-10)
    {
        LED_PWM(255-touchTimer);

        CheckUART();
}

```

```

        CheckTimer1();
        Read_TouchSensor();

        if (touchTimer<255)
            touchTimer++;
    };

    UpdateTouchPatterns(touchTimer);
    LED_PWM(255);
}

void WaitTouch3(void)
{
    LED_PWM(255);

    while (touchSensor < TOUCH_SENSOR_THRESHOLD+35)
    {
        CheckUART();
        CheckTimer1();
        Read_TouchSensor();
    };

    touchTimer=0;
    while (touchSensor >= TOUCH_SENSOR_THRESHOLD-10)
    {
        CheckTimer1();
        LED_PWM(255-touchTimer);
        Read_TouchSensor();
    };

    UpdateTouchPatterns(touchTimer);

    LED_PWM(255);
}

void SetupTimer1(void)
{
    //T1CON = 0b00001111;
    T1CON = 0b00111001;
    TMR1H = 0x80;
    TMR1L = 0x00;
    PIE1 = 0b00000000;
}

void WaitTimer1(void)
{
    while (!(PIR1 & 1))
    {}
    PIR1 &= 0b11111110;

    TMR1H |= 0x20;

    while (!(PIR1 & 1))
    {}
    PIR1 &= 0b11111110;

    //TMR1H |= 0x80;
}

void CheckTimer1(void)
{
    if (PIR1 & 1)
    {
        TMR1L |= 0xC0;
        TMR1H |= 0xF6;
        PIR1 &= 0b11111110;
        UpdateTime();
    }
}

void SendCharUART(char c)
{
    while (!(TXSTA & 0x02)) {}; // wait for previous character to finish sending
    TXREG = c; // now send this character
}

```

```

void nop(void)
{
    static unsigned char nopChar;
    nopChar++;
}

#define HUMIDITY_PAUSE                {nop();nop();nop();/*nop();nop();nop();*/}

#define HUMIDITY_POWER_ON              {PORTB |= 0b00001000; HUMIDITY_PAUSE}
#define HUMIDITY_POWER_OFF            {PORTB &= 0b11110111; HUMIDITY_PAUSE}

#define HUMIDITY_DATA_HIGH             {TRISB |= 0b00100000; HUMIDITY_PAUSE}
#define HUMIDITY_DATA_LOW             {TRISB &= 0b11011111; PORTB &= 0b11011111;
HUMIDITY_PAUSE}

#define HUMIDITY_CLOCK_LOW            {PORTB &= 0b11101111; HUMIDITY_PAUSE}
#define HUMIDITY_CLOCK_HIGH          {PORTB |= 0b00010000; HUMIDITY_PAUSE}

#define HUMIDITY_ACK                  {HUMIDITY_DATA_LOW
HUMIDITY_CLOCK_HIGH HUMIDITY_CLOCK_LOW HUMIDITY_DATA_HIGH}
#define HUMIDITY_WAIT_ACK             {TRISB |= 0b00100000; PORTB &= 0b11101111; }

void SetupHumidity(void)
{
    INTCON2 &= 0b01111111;           // PORTB Pullups on
    TRISB &= 0b11100111;           // Power and clock to low impedance
    HUMIDITY_DATA_HIGH
    HUMIDITY_POWER_ON
}

void ResetHumidity(void)
{
    static unsigned char i;

    for (i=0; i<10; i++)
    {
        HUMIDITY_CLOCK_HIGH
        HUMIDITY_CLOCK_LOW
    }

    nop();nop();nop();
    nop();nop();nop();
    nop();nop();nop();
    nop();nop();nop();
    nop();nop();nop();
}

void HumidityRead12BitValue(void)
{
    static unsigned char i;
    static unsigned int b;

    HResult = 0;
    HResultH = 0;
    HResultL = 0;

    HUMIDITY_CLOCK_HIGH            HUMIDITY_CLOCK_LOW
    HUMIDITY_CLOCK_HIGH            HUMIDITY_CLOCK_LOW
    HUMIDITY_CLOCK_HIGH            HUMIDITY_CLOCK_LOW
    HUMIDITY_CLOCK_HIGH            HUMIDITY_CLOCK_LOW

    b=0x0400;
    for (i=0; i<4; i++)
    {
        HUMIDITY_CLOCK_HIGH
        if (PORTB & 0b00100000) HResult |= b;
        HUMIDITY_CLOCK_LOW
        b>>=1;
    }

    HUMIDITY_ACK

    b=0x0080;
    for (i=0; i<8; i++)

```

```

    {
        HUMIDITY_CLOCK_HIGH
        if (PORTB & 0b00100000)    HResult |= b;
        HUMIDITY_CLOCK_LOW
        b>>=1;
    }

    //HResult >>= 3;
    //HResultL = HResult & 0xFF;
    HResultL = HResult & 0xFF;
    HResultH = HResult >> 8;

    HUMIDITY_DATA_HIGH
    HUMIDITY_CLOCK_HIGH
    HUMIDITY_CLOCK_LOW
}

void HumidityCommand(unsigned char command)
{
    HUMIDITY_DATA_LOW

    HUMIDITY_CLOCK_HIGH    HUMIDITY_CLOCK_LOW
    HUMIDITY_CLOCK_HIGH    HUMIDITY_CLOCK_LOW
    HUMIDITY_CLOCK_HIGH    HUMIDITY_CLOCK_LOW

    if (command & 16)    HUMIDITY_DATA_HIGH else HUMIDITY_DATA_LOW
    HUMIDITY_CLOCK_HIGH    HUMIDITY_CLOCK_LOW
    if (command & 8)    HUMIDITY_DATA_HIGH else HUMIDITY_DATA_LOW
    HUMIDITY_CLOCK_HIGH    HUMIDITY_CLOCK_LOW
    if (command & 4)    HUMIDITY_DATA_HIGH else HUMIDITY_DATA_LOW
    HUMIDITY_CLOCK_HIGH    HUMIDITY_CLOCK_LOW
    if (command & 2)    HUMIDITY_DATA_HIGH else HUMIDITY_DATA_LOW
    HUMIDITY_CLOCK_HIGH    HUMIDITY_CLOCK_LOW
    if (command & 1)    HUMIDITY_DATA_HIGH else HUMIDITY_DATA_LOW
    HUMIDITY_CLOCK_HIGH

    HUMIDITY_WAIT_ACK
    HUMIDITY_PAUSE
    HUMIDITY_CLOCK_HIGH
    HUMIDITY_CLOCK_LOW

    while (PORTB & 0b00100000)    // Wait for the sensor to finish sampling
    {
    }
}

void HumidityStart(void)
{
    HUMIDITY_DATA_HIGH
    HUMIDITY_CLOCK_LOW

    HUMIDITY_CLOCK_HIGH
    HUMIDITY_DATA_LOW
    HUMIDITY_CLOCK_LOW
    HUMIDITY_CLOCK_HIGH
    HUMIDITY_DATA_HIGH
    HUMIDITY_CLOCK_LOW
}

void HumidityEnd(void)
{
}

void ReadHumidity(void)
{
    HumidityStart();
    HumidityCommand(0x05);
    HumidityRead12Bit Value();
}

void ReadTemperature(void)
{
    HumidityStart();

```

```

HumidityCommand(0x03);
HumidityRead12BitValue();
}

void SetupPWM(void)
{
    CCP1CON = 0b00001100;
    PR2 = 63;
    T2CON = 0b00000101;
}

void LED_PWM(unsigned char brightness)
{
    CCPR1L = (brightness>>2) & 0b00111111;
    if (brightness & 1)    CCP1CON |= 0b00010000;    else CCP1CON &= 0b11101111;
    if (brightness & 2)    CCP1CON |= 0b00100000;    else CCP1CON &= 0b11011111;
}

/*
LEDS_ON                0
LEDS_OFF               1
LEDS_HEART_BEAT       2
LEDS_PANIC             3
*/

void SetupLEDPatterns(void)
{
    ledPatterns[LEDS_ON].numStates = 4;
    ledPatterns[LEDS_ON].levels[0] = 248;
    ledPatterns[LEDS_ON].levels[1] = 93;
    ledPatterns[LEDS_ON].levels[2] = 155;
    ledPatterns[LEDS_ON].levels[3] = 0;
    ledPatterns[LEDS_ON].rates[0] = 31;
    ledPatterns[LEDS_ON].rates[1] = -31;
    ledPatterns[LEDS_ON].rates[2] = 31;
    ledPatterns[LEDS_ON].rates[3] = -31;

    ledPatterns[LEDS_ON2].numStates = 3;
    ledPatterns[LEDS_ON2].levels[0] = 248;
    ledPatterns[LEDS_ON2].levels[1] = 128;
    ledPatterns[LEDS_ON2].levels[2] = 0;
    ledPatterns[LEDS_ON2].rates[0] = 8;
    ledPatterns[LEDS_ON2].rates[1] = -8;
    ledPatterns[LEDS_ON2].rates[2] = -4;

    ledPatterns[LEDS_OFF].numStates = 6;
    ledPatterns[LEDS_OFF].levels[0] = 247;
    ledPatterns[LEDS_OFF].levels[1] = 30;
    ledPatterns[LEDS_OFF].levels[2] = 90;
    ledPatterns[LEDS_OFF].levels[3] = 4;
    ledPatterns[LEDS_OFF].rates[0] = 8;
    ledPatterns[LEDS_OFF].rates[1] = -4;
    ledPatterns[LEDS_OFF].rates[2] = 8;
    ledPatterns[LEDS_OFF].rates[3] = -1;

    ledPatterns[LEDS_HEART_BEAT].numStates = 6;
    ledPatterns[LEDS_HEART_BEAT].levels[0] = 247;
    ledPatterns[LEDS_HEART_BEAT].levels[1] = 30;
    ledPatterns[LEDS_HEART_BEAT].levels[2] = 90;
    ledPatterns[LEDS_HEART_BEAT].levels[3] = 4;
    ledPatterns[LEDS_HEART_BEAT].rates[0] = 8;
    ledPatterns[LEDS_HEART_BEAT].rates[1] = -4;
    ledPatterns[LEDS_HEART_BEAT].rates[2] = 8;
    ledPatterns[LEDS_HEART_BEAT].rates[3] = -1;

    ledPatterns[LEDS_PANIC].numStates = 2;
    ledPatterns[LEDS_PANIC].levels[0] = 64;
    ledPatterns[LEDS_PANIC].levels[1] = 0;
    ledPatterns[LEDS_PANIC].rates[0] = 1;
    ledPatterns[LEDS_PANIC].rates[1] = -1;

    ledPatterns[LEDS_BLINK].numStates = 4;
    ledPatterns[LEDS_BLINK].levels[0] = 255;
    ledPatterns[LEDS_BLINK].levels[1] = 245;
    ledPatterns[LEDS_BLINK].levels[2] = 10;
}

```

```

ledPatterns[LEDS_BLINK].levels[3] = 0;
ledPatterns[LEDS_BLINK].rates[0] = 255;
ledPatterns[LEDS_BLINK].rates[1] = -1;
ledPatterns[LEDS_BLINK].rates[2] = -235;
ledPatterns[LEDS_BLINK].rates[3] = -1;

ledPatterns[LEDS_FADE_OUT].numStates = 6;
ledPatterns[LEDS_FADE_OUT].levels[0] = 240;
ledPatterns[LEDS_FADE_OUT].levels[1] = 128;
ledPatterns[LEDS_FADE_OUT].levels[2] = 64;
ledPatterns[LEDS_FADE_OUT].levels[3] = 32;
ledPatterns[LEDS_FADE_OUT].levels[4] = 16;
ledPatterns[LEDS_FADE_OUT].levels[5] = 0;
ledPatterns[LEDS_FADE_OUT].rates[0] = 16;
ledPatterns[LEDS_FADE_OUT].rates[1] = -16;
ledPatterns[LEDS_FADE_OUT].rates[2] = -8;
ledPatterns[LEDS_FADE_OUT].rates[3] = -4;
ledPatterns[LEDS_FADE_OUT].rates[4] = -2;
ledPatterns[LEDS_FADE_OUT].rates[5] = -1;

ledPatterns[LEDS_FADE_IN].numStates = 6;
ledPatterns[LEDS_FADE_IN].levels[0] = 16;
ledPatterns[LEDS_FADE_IN].levels[1] = 32;
ledPatterns[LEDS_FADE_IN].levels[2] = 64;
ledPatterns[LEDS_FADE_IN].levels[3] = 128;
ledPatterns[LEDS_FADE_IN].levels[4] = 224;
ledPatterns[LEDS_FADE_IN].levels[5] = 0;
ledPatterns[LEDS_FADE_IN].rates[0] = 2;
ledPatterns[LEDS_FADE_IN].rates[1] = 4;
ledPatterns[LEDS_FADE_IN].rates[2] = 8;
ledPatterns[LEDS_FADE_IN].rates[3] = 16;
ledPatterns[LEDS_FADE_IN].rates[4] = 32;
ledPatterns[LEDS_FADE_IN].rates[5] = -32;

ledPatterns[LEDS_DISTRESS].numStates = 4;
ledPatterns[LEDS_DISTRESS].levels[0] = 210;
ledPatterns[LEDS_DISTRESS].levels[1] = 0;
ledPatterns[LEDS_DISTRESS].levels[2] = 255;
ledPatterns[LEDS_DISTRESS].levels[3] = 0;

ledPatterns[LEDS_DISTRESS].rates[0] = 42;
ledPatterns[LEDS_DISTRESS].rates[1] = -42;
ledPatterns[LEDS_DISTRESS].rates[2] = 85;
ledPatterns[LEDS_DISTRESS].rates[3] = -85;
}

/*
//Sends nate to the Transmit Register
void putc(unsigned char nate)
{
    while(!(PIR1&0x10));
    TXREG = nate;
}
*/

char bin2hex[17] = "0123456789ABCDEF";

void PrintHex(unsigned char val)
{
    SendCharUART(bin2hex[val>>4]);
    SendCharUART(bin2hex[val&0x07]);
}

void PrintDecimalChar(unsigned char val)
{
    static unsigned char c, v;

    v = val;
    /*
    c='0';
    while (v>=100)
    {
        c++;
        v-=100;
    }
    */
}

```



```

SendCharUART(c);
*/
c='0';
while (v>=10)
{
    c++;
    v-=10;
}
SendCharUART(c);

c='0';
while (v)
{
    c++;
    v--;
}
SendCharUART(c);
}

void PrintTime(void)
{
    PrintDecimalChar(hours);
    SendCharUART(':');
    PrintDecimalChar(minutes);
    SendCharUART(':');
    PrintDecimalChar(seconds);
}

void Print(const rom char *str)
{
    static char i=0;
    char c;

    i=0;

    do
    {
        if (!(c = str[i++]))
            break;

        SendCharUART(c);
    }while(1);
}

void UpdateTime(void)
{
    if (touchTimer<255)
        touchTimer++;

    centiSeconds++;
    if (centiSeconds == 100)
    {
        centiSeconds=0;
        seconds++;
        if (seconds == 60)
        {
            seconds=0;
            minutes++;
            if (minutes == 60)
            {
                minutes=0;
                hours++;
                if (hours == 24)
                {
                    hours=0;
                }
            }
        }
    }
}

void CheckUART(void)

```

```

{
    static unsigned char c;

    if (PIR1 & 0x20)
    {
        c = RCREG;
        PIR1 &= 0b11011111;

        switch (c)
        {
            case 'T':
                timeChar=0;
                break;

            case 10:
            case 13:
                if (timeChar == 8)
                    SetTimeFromTimeString();

                timeChar=0;
                break;

            default:
                if (timeChar < 8)
                {
                    timeString[timeChar] = c;
                    timeChar++;
                }
                break;
        }
    }
}

void SetTimeFromTimeString(void)
{
    hours = (timeString[0]-'0')*10 + (timeString[1]-'0');
    minutes = (timeString[3]-'0')*10 + (timeString[4]-'0');
    seconds = (timeString[6]-'0')*10 + (timeString[7]-'0');
}

void UpdateTouchPatterns(unsigned char pulseLength)
{
    static unsigned char i, progress;

    for (i=0; i<NUM_TOUCH_PATTERNS; i++)
    {
        progress = TouchPatterns[i].progress;
        if ((TouchPatterns[i].max[progress] >= pulseLength) &&
            (TouchPatterns[i].min[progress] <= pulseLength) )
        {
            progress++;
            TouchPatterns[i].progress = progress;
            if (progress == TouchPatterns[i].numPulses)
            {
                TouchPatternIdentified(i);
            }
        }
        else
            TouchPatterns[i].progress = 0;
    }
}

void TouchPatternIdentified(unsigned char pattern)
{
    static unsigned char q;
    q++;
    q++;
    q++;
}

void SetupTouchPatterns(void)
{

```

```

TouchPatterns[0].min[0] = PRESS_MIN;
TouchPatterns[0].max[0] = PRESS_MAX;
TouchPatterns[0].numPulses = 1;
TouchPatterns[0].progress = 0;

TouchPatterns[0].min[0] = STROKE_MIN;
TouchPatterns[0].max[0] = STROKE_MAX;
TouchPatterns[0].min[1] = STROKE_MIN;
TouchPatterns[0].max[1] = STROKE_MAX;
TouchPatterns[0].min[2] = STROKE_MIN;
TouchPatterns[0].max[2] = STROKE_MAX;
TouchPatterns[1].numPulses = 3;
TouchPatterns[1].progress = 0;

TouchPatterns[2].min[0] = SMACK_MIN;
TouchPatterns[2].max[0] = SMACK_MAX;
TouchPatterns[2].min[1] = SMACK_MIN;
TouchPatterns[2].max[1] = SMACK_MAX;
TouchPatterns[2].min[2] = SMACK_MIN;
TouchPatterns[2].max[2] = SMACK_MAX;
TouchPatterns[2].min[3] = SMACK_MIN;
TouchPatterns[2].max[3] = SMACK_MAX;
TouchPatterns[2].min[4] = SMACK_MIN;
TouchPatterns[2].max[4] = SMACK_MAX;
TouchPatterns[2].numPulses = 5;
TouchPatterns[2].progress = 0;
}

```

The next step was to develop software to support the GSR module.

There were three main drivers for developing this software:

1. To maintain control over all BABY-BLUE technologies.
2. To keep the patient pro-active in monitoring their personal statistics. Patient participation allows medical parameters to be recorded for future use by their professional medical adviser.
3. To maintain absolute transparency of personal data that is being recorded by the BABY-BLUE technologies, and their active state.

Supporting software was later developed to allow the patient to seamlessly view and manage vital data about themselves and their medication. All patient parameter data would be transferred from the active BABY-BLUE jewellery and stored as clinical data, ready for the patient to view their personal progress. Fig. 45 details the graphical user interface for personalising BABY-BLUE jewellery.

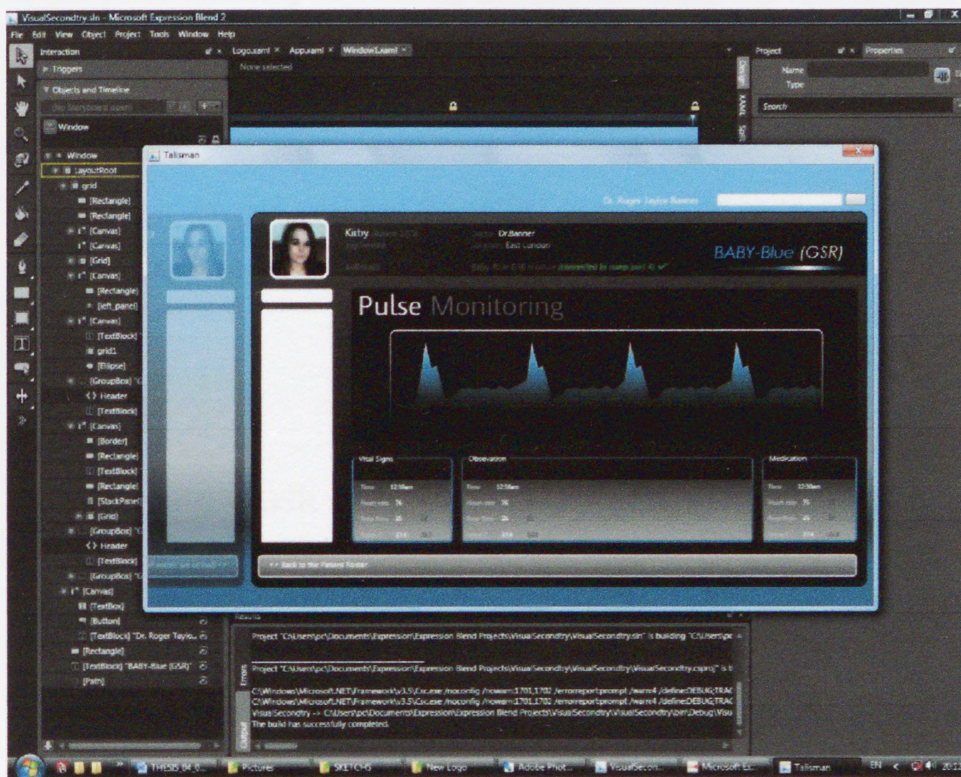

**Fig. 45**  
Interactive Personalised Metabolic Management  
Tool to Support BABY-BLUE GSR Module  
2007  
Developed by Leon B M Williams in Visual  
Studio and Expression Blend

Shadow Robotics, London  
Royal College of Art, London

## INTEGRATING BLUETOOTH TECHNOLOGY

*- Considerations on Integrating BLUE-Tooth Technology -*

The circuits developed here allow the patient to seamlessly connect and communicate with the BABY-BLUE GSR module using a personal computer or laptop. All circuits rely on BLUE-Tooth serial protocols to interface wirelessly with any other portable device that has integrated BLUE-Tooth receiving capabilities. BLUE-Tooth radio was chosen as the most suitable close proximity communication technology as it maintains an extremely robust wireless connection that can be configured remotely - meaning that the end user has the ability to choose when to activate the BABY-BLUE GSR module.

The BABY-BLUE GSR module interacts with other BLUE-Tooth devices on the command of the wearer. The module is designed to remain 'inactive' before two conditions were met in consecutive order. The first condition is brought about when the user interacts with the jewellery, causing either of the two on-board sensors to pull the microcontroller out of a 'reset mode'. This instantly informs the microcontroller to transmit a 'connection signal' to any nearby wireless devices that has BABY-BLUE bi-directional communication capabilities. The second condition is dependent on this connection: if a signal is received successfully by another device, it will promptly produce a return signal to the module informing the microcontroller to begin relaying data at 2400-115200 bits per second. However, in the event that the BABY-BLUE GSR module is unable to



Notice in this schematic diagram that all voltage terminals are supported by a 3.3v lithium-ion battery as standard. A blue light-emitting diode has also been integrated for indicative purposes, to ensure the circuit receives adequate power, and that programme procedures are being executed, as intended. To maintain a tight circuit and to avoid it being too large for use within jewellery the sensor, controller, BLUE-Tooth module and lithium-ion battery were stacked upon each other.

The purpose of adding an additional return signal is to ensure that the jewellery will only be sending data when a bi-directional device is switched on. Furthermore, the modules will be able to store data for up to three separate devices simultaneously. This is achieved by sending with every transmission a code reference with every reading. This means that the same device can even be used for various medical conditions, if several people require the use of the same module. This intentional feature brings into focus the usefulness of jewellery - where the module is made active through its tactile application.

Because one half of the system, (jewellery and modules) operate passively, drawing on the lithium-ion battery sporadically for long periods of time, the need for bulky components is reduced and the lifespan of the battery is prolonged, this avoiding the need for frequent recharging. The close-range wireless system offers a simple, touch sensitive solution, which allows the user to access information immediately in a logical and intuitive way. All

the modules operate in a 2.4~2.524 GHz frequency range, making it possible to communicate indoors and outdoors in the open air at up to 350ft.

**TABLE 2: ADDITIONAL COMMUNICATION FEATURES OF THE BABY-BLUE GSR MODULE**

BabyBLUE Radio  
Built-in antenna  
Robust link both in integrity and transmission distance  
Power consumption : 25mA – 50mA  
Frequency: 2.4~2.524 GHz  
Operating Voltage: 3.3V-3.7V  
Serial communications: 2400-115200bps  
Operating Temperature: -40 ~ +70C  
On-board SHT15 digital humidity and temperature sensor  
On-board 2 Axis - ADXL203 +/-1.5g (movement sensor)

A number of tests determined the configuration and the connection of appropriate input and output terminals on both boards. These issues were later corrected so that the device could transmit data without interference. When combined, the module measured approximately L15xW30xH4.8mm, which pushed its physical limitations in terms of its use as an item of jewellery.



## BABY-BLUE TEST TRIALS

- Problem Solving -

A 24-hour volunteer test phase was conducted on the BABY-BLUE GSR (as shown in Figs. 49-50). The aim was to see how the module reacted under pressures of daily use, including at night when the participant was sleeping. The participant was instructed to touch the sensitive parts of the module every hour, on the hour, throughout the day, and every 3 hours at night, in different rooms of the house. The objective was to see how the module could respond and transmit data in real-time to a nearby laptop or store parameter data until the laptop was in range.

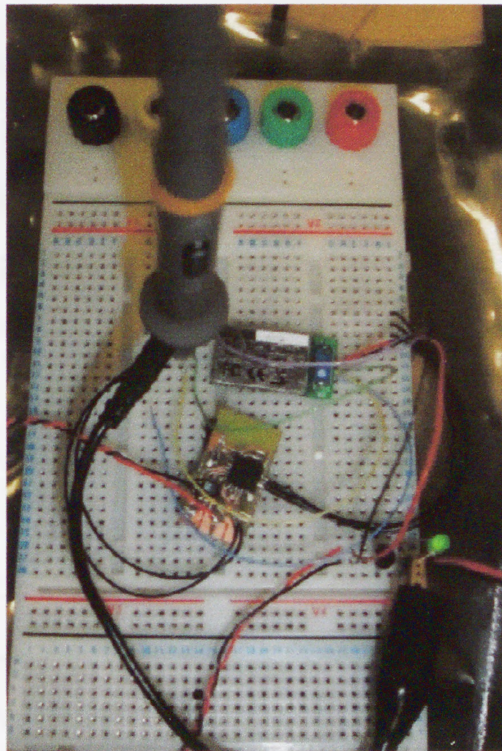

**Fig. 47**

Populated Sensor with RN4-BLUE-Tooth Module and 3.3v Lithium-ion Battery  
2007  
© Leon B M Williams

Royal College of Art, London

Fig. 48 demonstrates the action of activating the module. The participant was encouraged to wear the piece as if it was any item of jewellery –

meaning that in the event that the module would break or cease to function, the procedure of touching the module as instructed should still be followed.

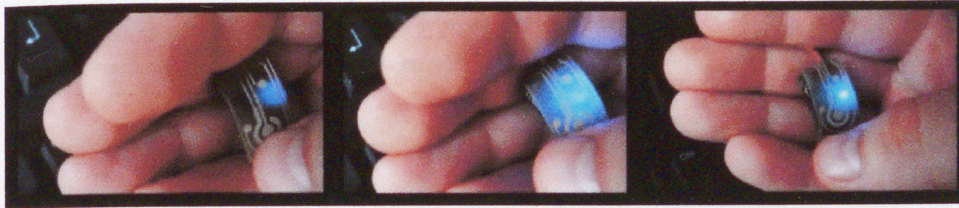

**Fig. 48**

Sequence of Photographs Detailing the  
Activation of the BABY-BLUE GSR  
Module

2007

© Leon B M Williams

Centre for Jewellery Research,  
Royal College of Art, London

The module was successful in monitoring skin humidity and sweat content over the 24-hour period. However some anomalies did occur in the results: between the hours of 3:00am and 6:00am the module did not respond. After close inspection of the module at the end of the experiment the touch pad showed signs of fatigue possibly caused by consistent movement at the connecting end of the flexible touch pad. This physical damage could have been caused whilst the participant was asleep. The transition of data did however reinstate after 6:00am. The problem was narrowed down to two possibilities: the handling of the fatigued pad, combined with a blocked signal, as the participant moved into different rooms; the exposed conductive elements of the module could have been splashed with water around 3:00 am causing the module to maintain an active state until it dried. The floor diagram in Fig. 49 details the movement of the participant as she activated the BABY-BLUE GSR module in different rooms of the house to check how it responds to obstacles such as walls and doors.

## TRIAL TESTING THE GALVANIC SKIN RESPONSE MODULE OVER A 24-HOUR PERIOD

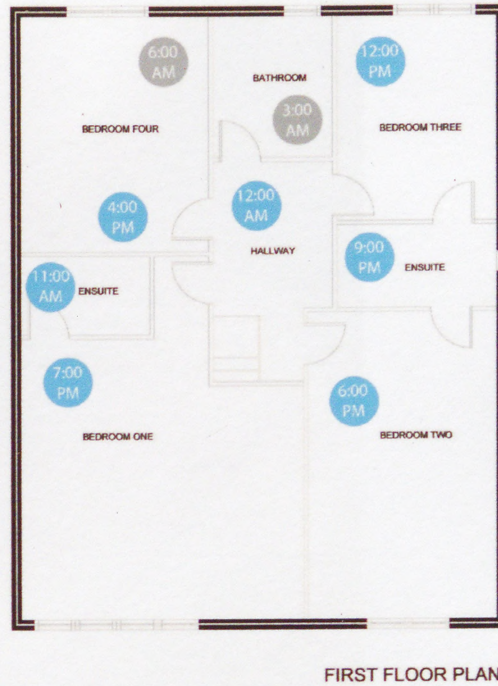
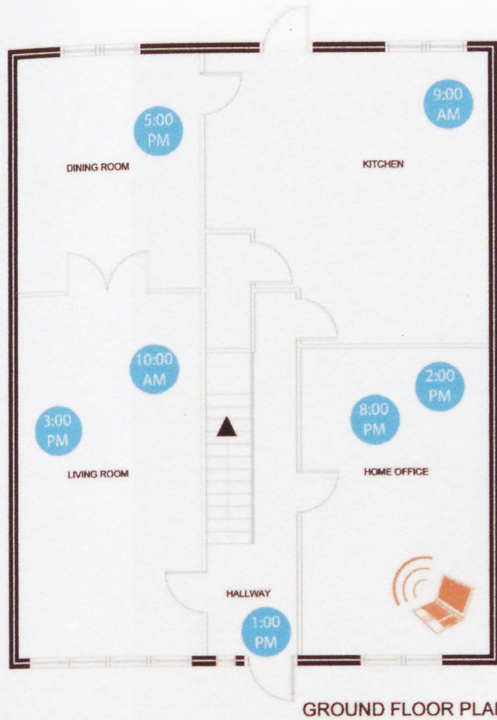

The floor plans show the movements of the participant over a 24-hour period. The participant was encouraged to actively interact with the BABY-BLUE Galvanic Skin Response module in different rooms of her house. The 'blue spots' closely approximate the participant position when the module was activated, as the 'greyed out spots' are indicative of the two unsuccessful transmissions from the module to the laptop.



Successful Activation



No Response or Reading



Laptop Position

<< **Fig. 49** (Previous Page)

Trial Testing the Galvanic Skin Response Module over a  
24-hour period,

2007

© Leon B M Williams

Centre for Jewellery Research,  
Royal College of Art, London



**Fig. 50**

Trial Testing the Galvanic Skin Response Module over a  
24-hour period,

2007

© Leon B M Williams

Centre for Jewellery Research,  
Royal College of Art, London

On a technical note, the module at its core used a combination of flat or flexible Printed-Circuit-Boards<sup>26</sup> to hold, support and interconnect various electrical components together, as without it, the module could not function. This research demonstrates the combined use of stacking, multi-layering and folding boards together to mimic basic structural forms. The drawback with this process is that it invariably means an increase of interlocking components, which in turn brings the overall package size of the BABY-BLUE module beyond a size that would be suitable for very small jewellery types, like rings, but otherwise appropriate for use in many other jewellery applications.

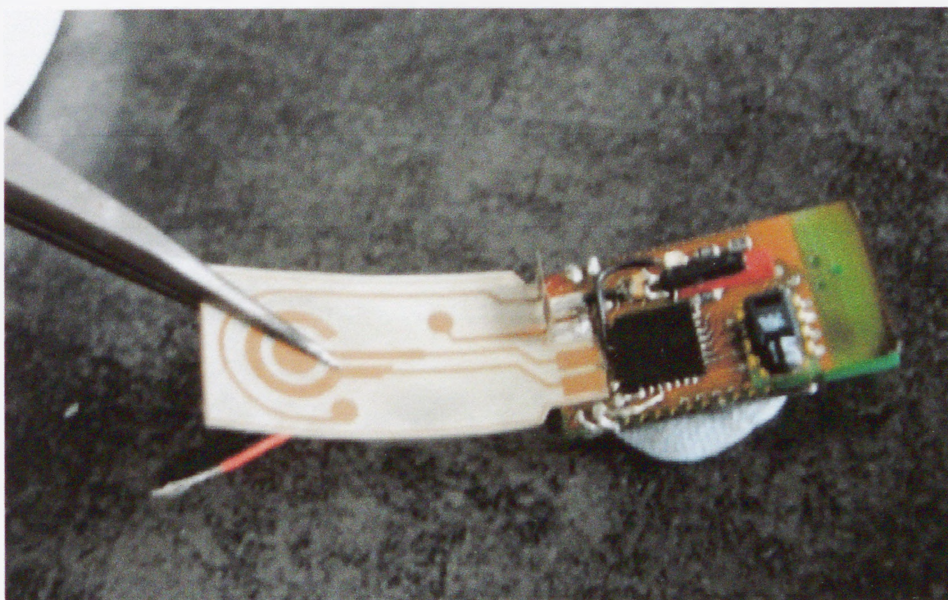

**Fig. 51**  
BABY-BLUE GSR Module,  
2007  
© Leon B M Williams

Centre for Jewellery Research,  
Royal College of Art, London

<sup>26</sup> The basic printed-wiring-boards are strengthened by a substrate material such as heat resistant glass-reinforced epoxy-resin. A conductive copper foil is typically adhered onto this surface so that selective parts of the copper can then be removed, etched or CNC milled. If successful, the remaining material will form a wire-like image suitable for soldering electrical components. This formation of wire patterns and soldered components allows for an electrical conductive circuit to flow from one component to another. When the board is populated with components a fully integrated Printed-Circuit-Board (PCB) is made.

On reflection, the BABY-BLUE GSR module proved effective in silently transferring parameter data between the hours of 2:00pm to 3:00am and 6:00am onwards. The exposed components and touch pad showed signs of damage after the 24-hour experiment.

## CONDUCTIVE CIRCUIT IMAGERY

*-The Development of Rigid and Flexible Circuits for use in Jewellery Applications-*

This section details various technical processes used to further refine BABY-BLUE jewellery. Here I demonstrate various credible and elegant alternatives for the fabrication of practical and decorative circuit imagery on complex surfaces. Aesthetics begin to play more of a part here, as the designer/maker is given the freedom to apply circuit imagery in many creative ways. All test samples were made and trialled to show the evolutionary developments of conductive imagery, whilst reviewing how different wire patterns could be used to offer different touch sensitive responsiveness. There are many benefits in using conductive imagery within jewellery application. If applied correctly, the new techniques and fabrication processes detailed in this part of the research, could be applied by the designer/maker to further develop an infinite array of touch sensitive innovations for medical or commercial use.

## RE-DESIGNING THE BABY-BLUE CIRCUIT BOARD

*-Developing Flat and Flexible Circuit Boards for use as Part of the BABY-BLUE GSR Module-*

Most circuit manufacturers today use software to design printed-wiring-patterns (PWPs) to fabricate printed-wiring-boards (PWBs). Normally, wire patterns are transferred onto a board through a process of etching or milling to reveal a network of interconnecting grid-like-patterns. These can be connected together using components, such as programme interrupt controllers (PICs), capacitors, or electrical sensors. This traditional way of making circuits can be highly effective, yet at the same time aesthetically limiting, making the components unsuitable for small scale devices such as the BABY-BLUE module developed in the previous chapter, and unusable for creating conductive imagery as part of a surface.

Most digital technologies hold and carry circuits that have been fabricated using the conventional printed wiring patterns process. To overcome this problem I have developed a new printed wiring pattern process that removes many design and aesthetic restrictions. All test samples have been designed to conform to a scale suitable for jewellery, beginning with the development of a conductive image on flat and flexible circuit boards, and then moving on to more complex curved and twisting surfaces. Fig. 52 shows four different BABY-BLUE GSR wire pattern alternatives, developed to show how complex circuit imagery can be elegantly redesigned to create different printed wiring board configurations:



## FOUR BABY-BLUE GSR PRINTED-WIRING-BEARD VARIATIONS

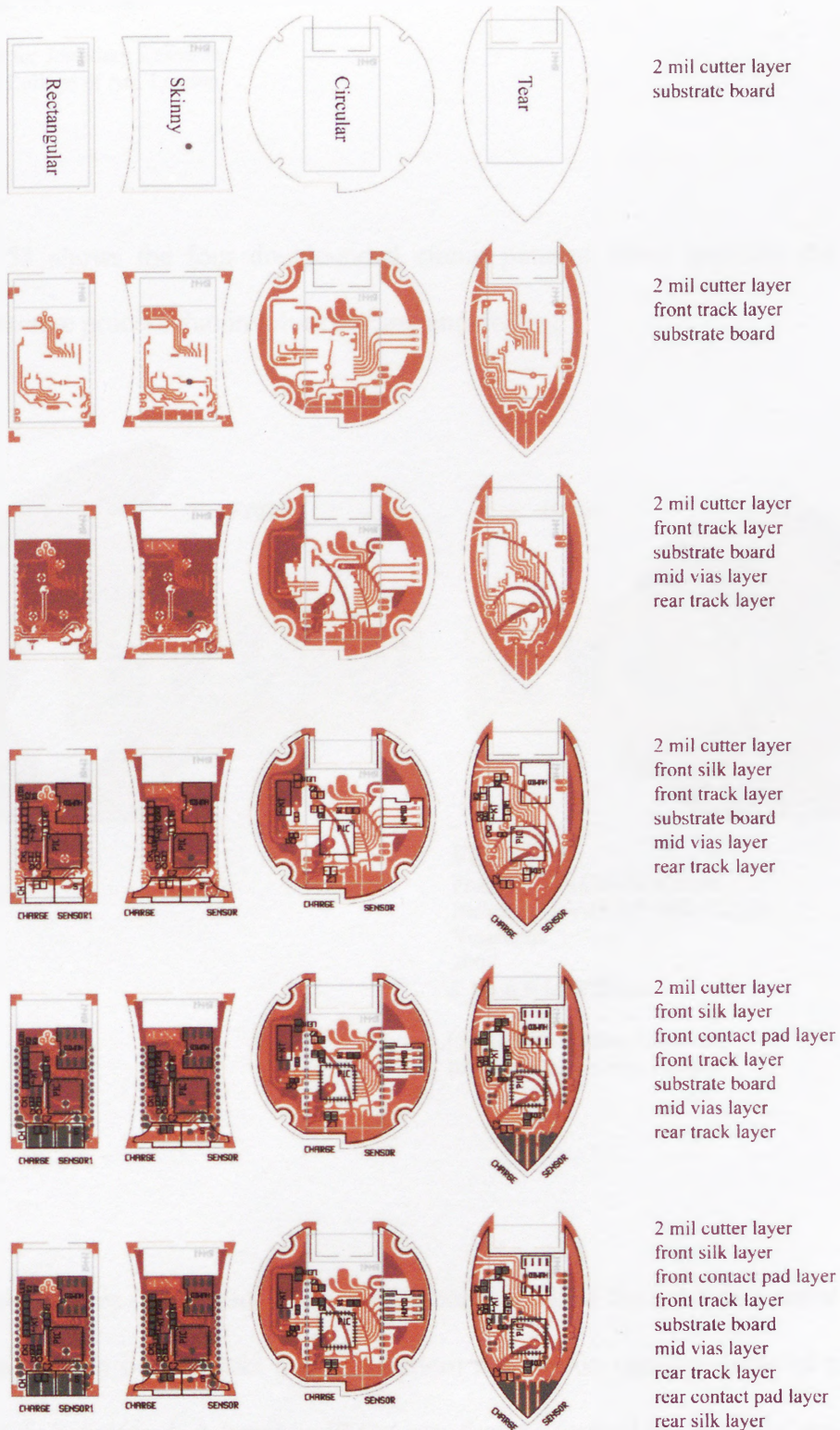

The four variations were developed using three vector based software packages; PCB by gEDA; Rhino3 by Robert Mc Neal; and Adobe Illustrator CS3. When combined these packages can free the developer of many design and printing restraints – meaning that a precise and fluid image pattern can be developed to accommodate many circuit board configurations for use in jewellery applications

<< **Fig. 52 (Previous Page)**

Four BABY-BLUE GSR Printed Wiring Board  
Variations,  
2007  
© Leon B M Williams

Centre for Jewellery Research,  
Royal College of Art, London

Fig. 53 shows the four double-sided circuit patterns when applying the subtractive process that involves etching and drilling.

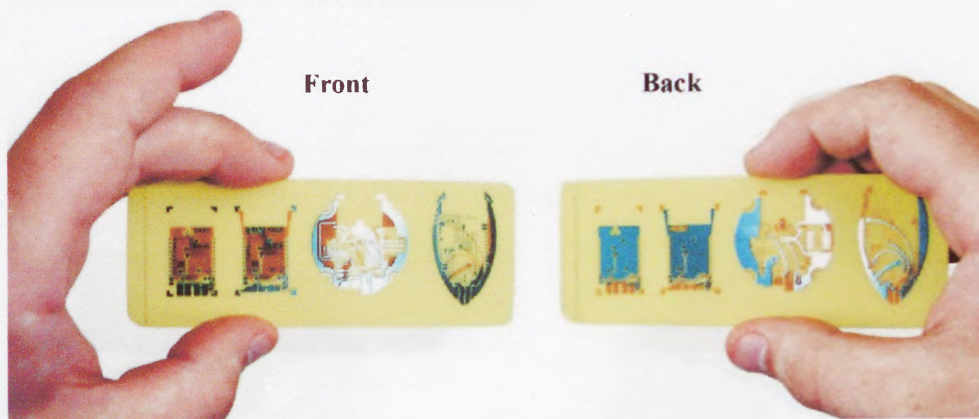

**Fig. 53**

Front and Back View of Four  
Etched BABY-BLUE GSR Circuit  
Variations,  
2007  
© Leon B M Williams

Centre for Jewellery Research,  
Royal College of Art, London

Through-holes (vias) were made in each board to allow for a 0.2 mm round copper pin to interconnect a circuit pattern running on opposite sides of a flat substrate board. A panel audit test was then performed to check for any loose connections. All loose ends and solder pads were given an additional gold or nickel flash plating of approximately 3-5 microns to increase its

electrical conductivity and to reduce electrical resistance caused by wire breaks. Thin boards of a thickness less than 0.4 mm are likely to flex or apply strain on the wire patterns. If the board bends too much, it could cause the wire patterns to break under pressure, reducing the performance of the sensors, or even preventing the module from working altogether. All four rigid circuits were tested for resistance and performance. They all gave results levels less than 2 ohms<sup>27</sup> - meaning that there were no signs of fatigued wires. The following image shows the circular version mounted with the three main electrical components:

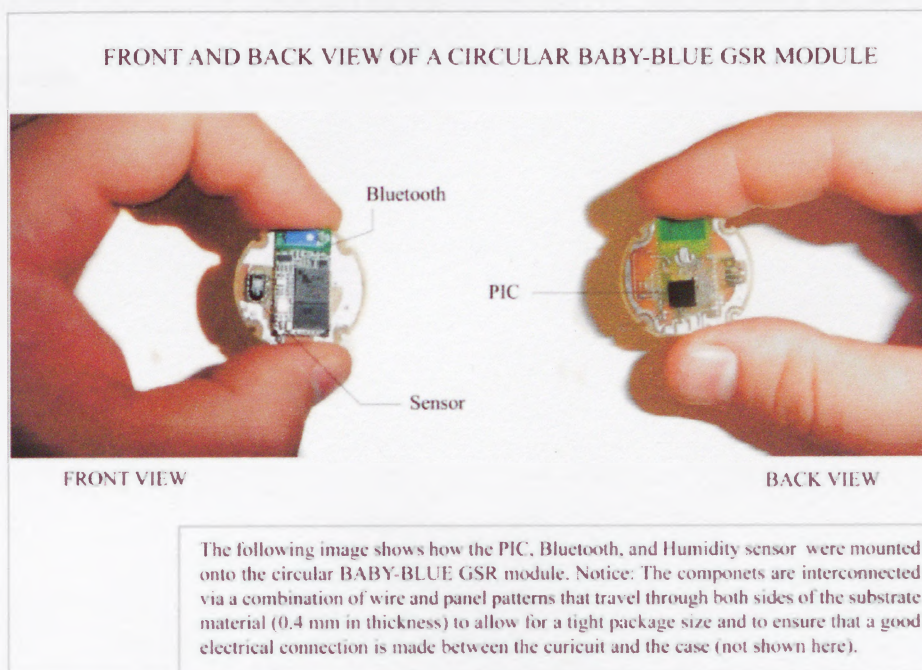

**Fig. 54**

Front and Back View of Circular BABY-BLUE GSR Module Assembly  
2007

© Leon B M Williams

Centre for Jewellery Research,  
Royal College of Art, London

<sup>27</sup> Ohm's Law:  $I = V/R$  - current (I) is equal to the difference in voltage (V) divided by resistance (R).

By redirecting the wiring around or underneath large cumbersome components like the PIC, humidity sensor, or BLUE-Tooth module size of the board-footprint size could be greatly reduced. Multi-layer boards can be made more easily by stacking double-layered boards together ensuring a highly accurate wiring match with excellent compatibility for assembly when soldering 'rigid' to 'flexible' substrates. The touch sensor prototype will need to be fixed within difficult spaces or be fabricated in three-dimensions. Due to the limitation of size and shape, some jewellery forms may need to be broken up into two or more parts. In such cases a flexible circuit connector could be used. Fig. 55 demonstrates the new fabrication process (specifically designed for the craftsman) to create flexible connector circuits:

FLEXIBLE CONDUCTIVE SUBSTRATES USED TO CONNECT THE FLAT-RIGID BABY-BLUE GSR MODULE TO A NON-UNIFORM TOUCH SENSITIVE SURFACE.

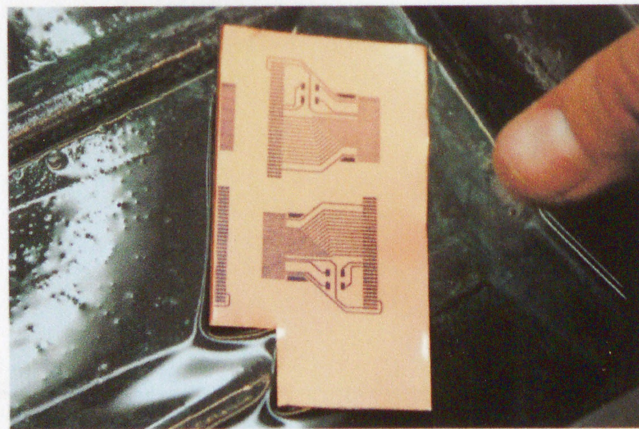
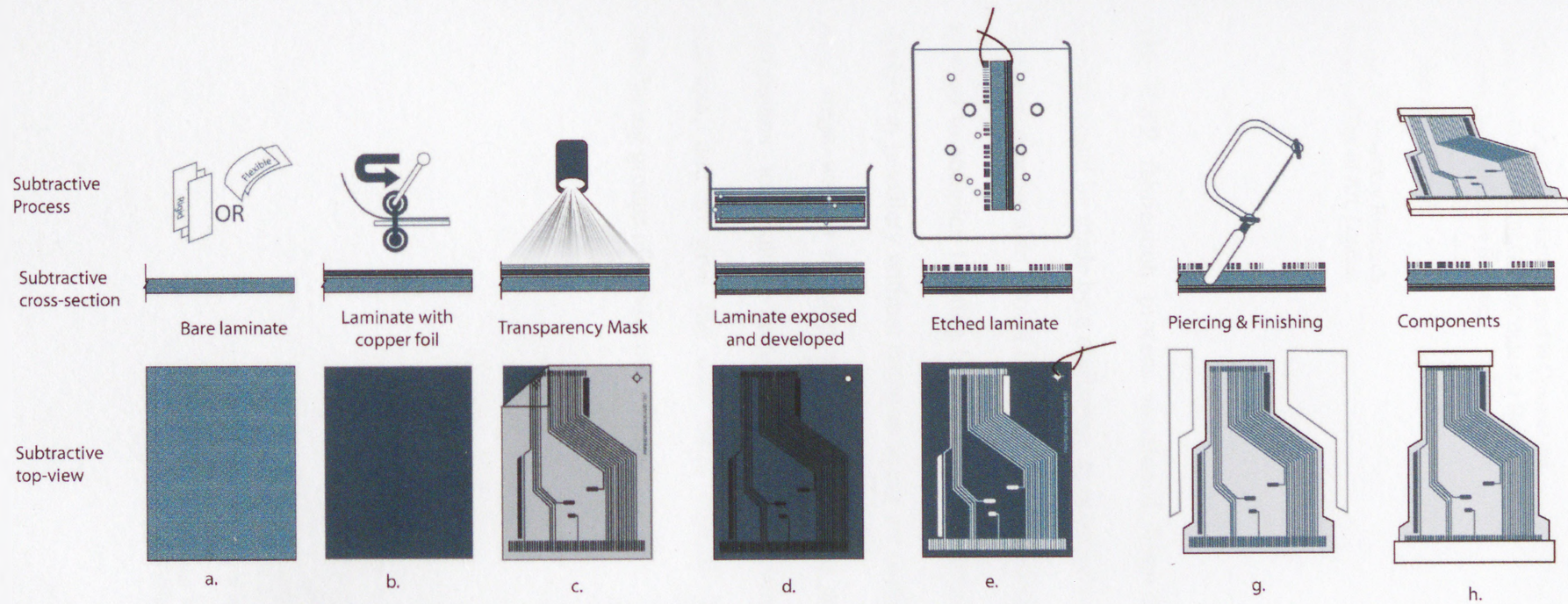

Laminate cross-section

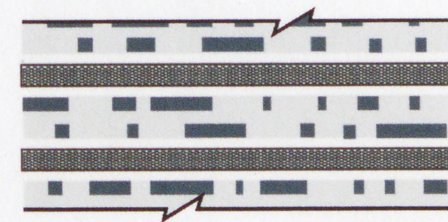

Inner layer core  
Bondable adhesive  
Inner layer core

The simplified subtractive process for fabricating the inner layers of the Rigid Multi-layer. (a through i) and a cross-section of the of three inner-layer cores with a multi-layer structure. (i).

<<**Fig. 55** (Previous Page)

Flexible Conductive Substrates used to Connect the  
Flat-Rigid BABY-BLUE GSR Module to a Non-  
Uniform Touch Sensitive Surface,  
2007  
© Leon B M Williams

Centre for Jewellery Research,  
Royal College of Art, London

The PWP fabrication process developed here demonstrates how new circuits could be made by a craftsman, as opposed to a circuit manufacturer. The new process also allows for wire patterns and conductive imagery to be applied to complex twisting boards and touch sensitive pads that could be applied in jewellery without compromising the aesthetics or the design. The next stage was to develop a method of using several patterns or wire formations to acquire better touch responsiveness over non-uniform surfaces, and to give the user more control. This was achieved by interlacing groups of conductive patterns.

**Fig. 56** (Next Page) >>

Scarab Pendant Design with Integrated  
BABY-BLUE GSR Module  
2007-2008  
© Leon B M Williams

Centre for Jewellery Research,  
Royal College of Art, London

# SCARAB PENDANT DESIGN WITH INTERGRATED BABY-BLUE (GSR) MODULE

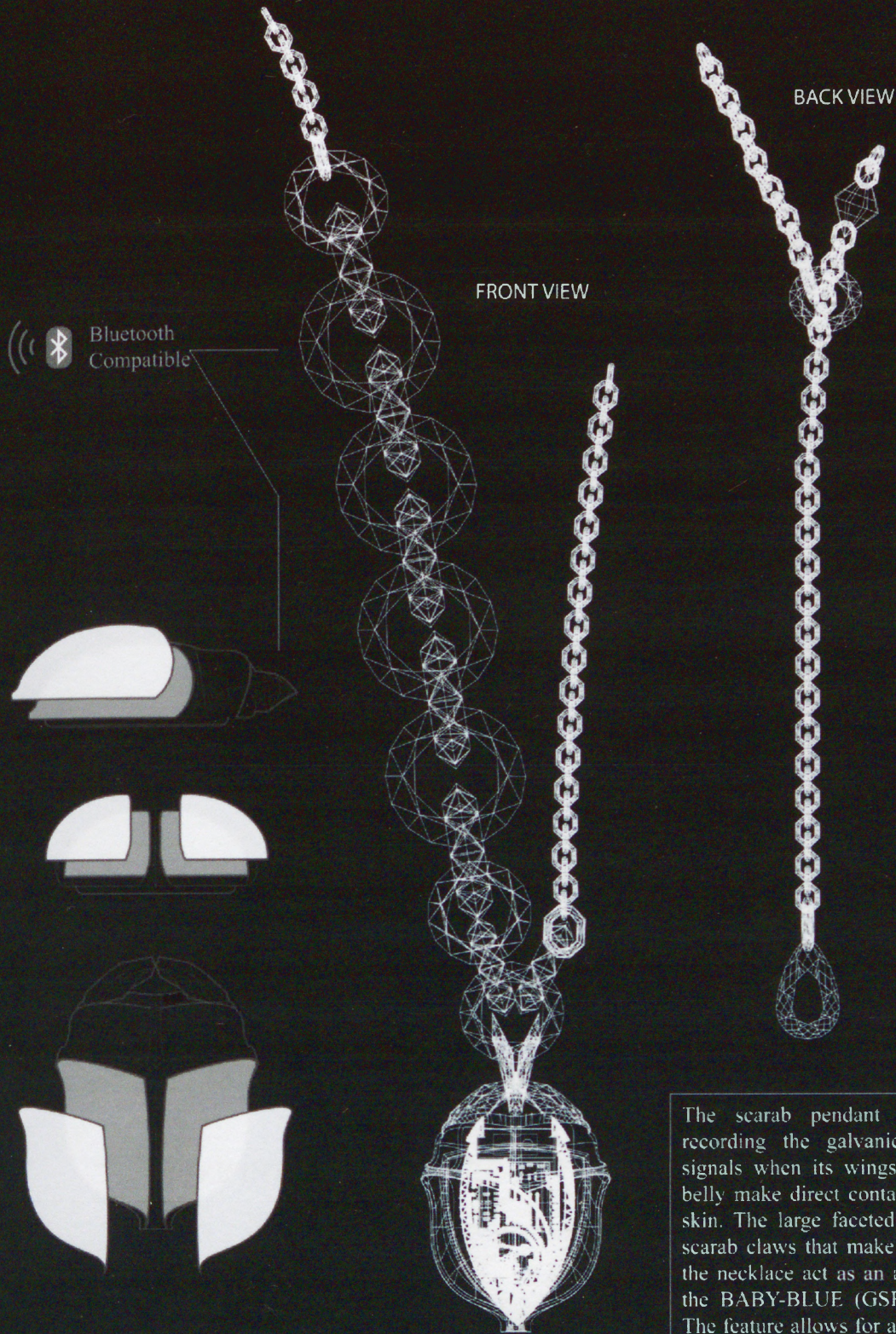

SCARAB PROFILES SCALE 1:1

The scarab pendant works by recording the galvanic response signals when its wings or underbelly make direct contact with the skin. The large faceted loops and scarab claws that make up part of the necklace act as an antenna for the BABY-BLUE (GSR) module. The feature allows for an electrical signal to be sent or received on command using a nearby laptop.

# CHAPTER 3

## TOUCH SENSITIVE JEWELLERY

<b>FABRICATING TOUCH-SLIDER PADS FOR JEWELLERY APPLICATIONS</b> <i>Developing Rigid, Flexible and Curved Touch Slider Technology</i>	113
<b>CURVED CONDUCTIVE SURFACE</b> <i>Refining the Circuit Imagery on Curved Surfaces</i>	117
<b>ENCLOSED JEWELLERY</b> <i>Development of Circuit Imagery on Enclosed Objects</i>	124
<b>MORE COMPLEX MEDICATION CARRIERS</b> <i>Developing Complex Jewellery Forms for Carrying Different Types of Medications</i>	128
<b>DEMANDS TO IMPROVE THE SELF-CARE DEVICE</b> <i>The Effective use of BABY-BLUE Jewellery</i>	135
<b>CONDUCTIVE GEMSTONES</b> <i>Developing a Universal Charging Mechanism</i>	136
<b>PORTABLE BABY-BLUE CHARGER</b> <i>Developing a Portable Charging Device</i>	141
<b>BRIEF INTRODUCTION TO THE THREE CASE STUDIES</b> <i>The Patient and Physician</i>	147



## FABRICATING TOUCH-SLIDER PADS FOR JEWELLERY APPLICATIONS

*-Developing Rigid, Flexible and Curved Touch Slider Technology-*

Here a combination of circuit etching, milling and hand finishing was applied to fabricate multiple conductive patterns on a flat substrate board. When the conductive patterns are separated into parts, a basic 'grid-like' structure is made. These in turn form an interlocking pattern that can be used as part of a touch sensitive slider. As the patient interacts with the silver or gold patterns on the board, the device becomes active. When the finger, wrist, or palm passes from one set of conductive patterns to another, the touch slider sends data signals to a nearby PIC identifying when and where the surface is touched. This technology, if applied to future medical jewellery (or any other medical device) could greatly improve the way in which medical devices are being ergonomically handled. Patients would be given the ability to see if they are carrying, holding, or using their medical product correctly, even when administering or transporting their medications.

To refine a suitable design pattern that would best demonstrate the capabilities of this newly developed touch-slider technology, conductive wire patterns were first developed using flat-rigid substrate boards. The key fabrication stages included a combination of 'additive' and 'subtractive' processes. The additive process involved the selective application of silver or gold to all the conductive components. This allowed for better electrical

conductivity whilst effectively holding the delicate wires in the surface of the jewellery. The subtractive process of "print-and-etch" permitted the selective removal of conductive copper, silver or gold layers to release fragile wires. Fig. 57 shows the subtractive process being applied to make a touch slider.



**Fig. 57**

(a. through i.) Four Different Possibilities for the BABY-BLUE Galvanic Skin Response Module. Circuit etching and machining is used to achieve a compact printed circuit and touch sensitive pad  
2008

© Leon B M Williams

Centre for Jewellery Research,  
Royal College of Art, London

A further flash plating of 2-3 microns of nickel-gold or tin-alloy was applied to the circuit pattern (with +/-0.025 tolerance) to provide extra strength. The next stage was to develop a test-board that could

accommodate a small screen so that it would be possible to reveal how the device responds to touch. The images in Fig. 58 show in detail the development of a printed circuit board, specifically designed to test different pattern configurations. Each pattern was tested using a 128 by 128 full colour organic light emitting diode screen (OLED).

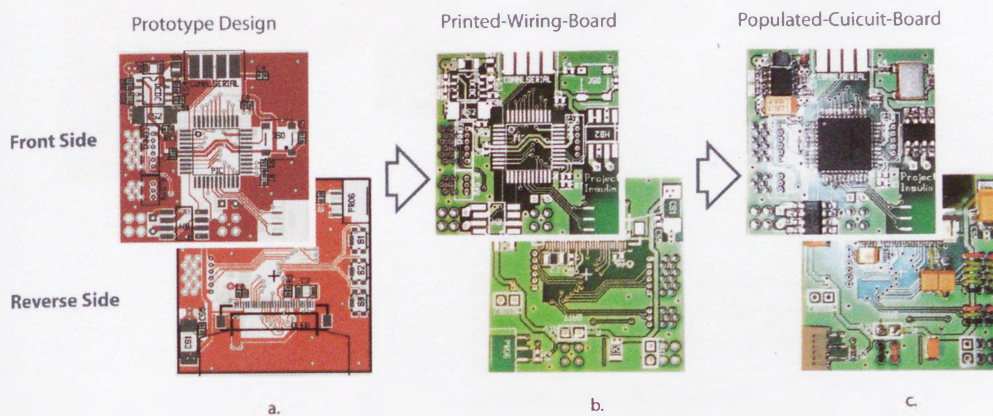

**Fig. 58**

(a. through c.) Show the Three Main Stages to Make and Populate a Circuit Board for use with Conductive Imagery and a 128 x 128mm Colour Screen  
2008

© Leon B M Williams

Shadow Robotics, London  
Royal College of Art, London

Since the circuit boards will be encased within jewellery forms, careful consideration of the design of the case and shells were needed to ensure that obvious seam lines throughout the jewellery are reduced or removed altogether. This will enable the outer case to remain clean and ensure that the two shells that have been fitted together to produce the overall case do not separate, when pressure is applied on the unit, such as by the memory card when fully inserted.

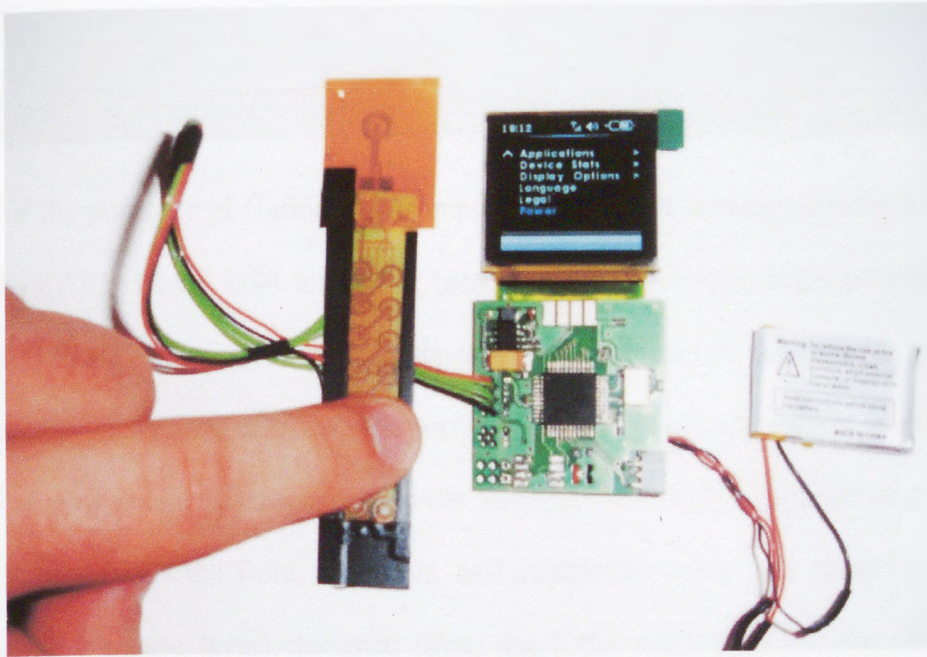

**Fig. 59**

First Generation Touch-Slider with 128 x 128 full  
Colour Display (based on the BABY-BLUE module)  
Copper circuit on polymer substrate  
2007

Analogue to digital converter  
© Leon B M Williams

Centre for Jewellery Research,  
Royal College of Art, London

The metallic pattern proved successful in trial testing. As the finger made contact with the copper pattern, a digital signal was passed to the device and used to identify its position. The technology is applied here as part of an interactive touch slider, but can be adapted in various future touch response jewellery applications

## CURVED CONDUCTIVE SURFACE

*-Refining the Circuit Imagery on Curved Surfaces-*

For the purposes of clarity, it was important to further develop and improve the BABY-BLUE GSR touch pad, (described and developed in the previous chapter). The objective was to re-develop the flexible touch pad to include a more hardwearing and durable surface, shell, or case alternative, whilst retaining excellent sensory sensitivity and touch-interactive responsiveness. Fig. 60 shows the front, rear, side, and perspective view of a curved pad (substrate base layer) designed using the CAD software Rhino3D. This simple form was selected to demonstrate how different conductive wire imagery can be applied to a curved surface in jewellery.

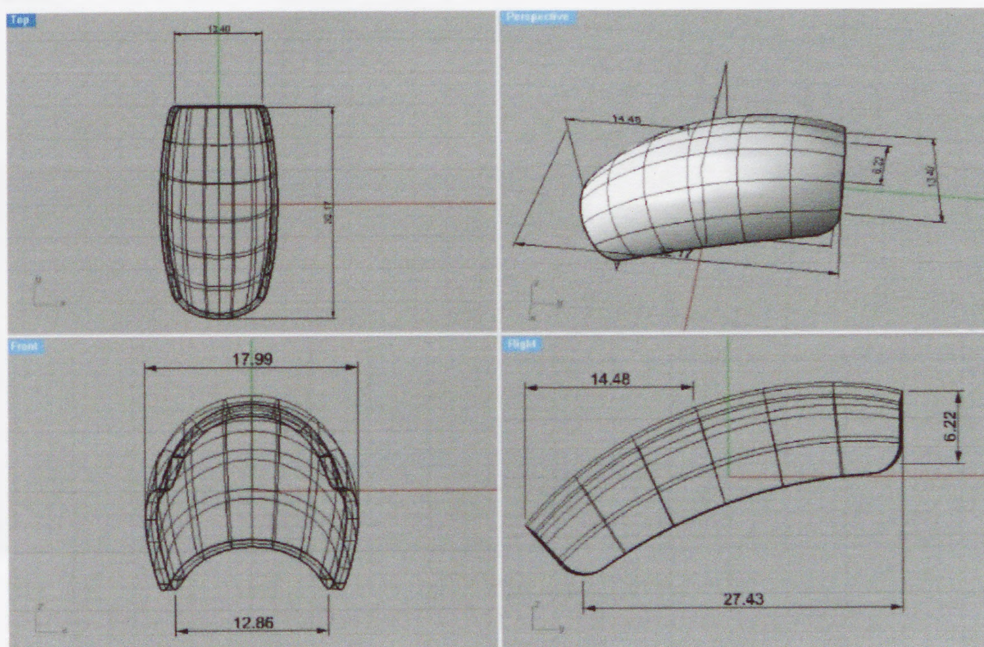

**Fig. 60**

Dimensional Drawing of a Newly Developed Curved Surface Substrate

2009

The objective was to trial test the most effective method of applying conductive imagery on the curved surfaces.

© Leon B M Williams

Centre for Jewellery Research,  
Royal College of Art, London

Using CAD software, each touch pad was individually modelled with different surface engraved detailing and then rapid-prototyped, developing a select number of basic patterns that would reveal responsiveness through trial testing, with the intention of using them as part of the touch sensitive circuit. On a miniature scale, pits, valleys, walls and depressions can be seen. The computer-generated engraved detailing on the individual surfaces was used to divide up the surface into parts after translation from a virtual model into a real object (*via rapid prototyping*). A base coating layer of conductive paint is applied to the entire form. The additive deposition (*plating*) process could be followed, building up a durable layer of silver or copper. A final process of filing back and a 6 micron layer of gold-plating would reveal the durable pads, platelets, and wire circuit patterns that passed over and through the surface.



**Fig. 61**

First Generation Substrates with Engraved Patterns  
Envisiontec rapid prototyped finger shaped pad. E-Shell 100 resin  
2008  
© Leon B M Williams

Centre for Jewellery Research,  
Royal College of Art, London

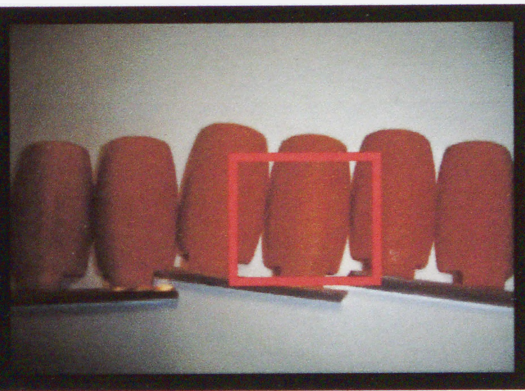

**Fig. 62**

Second Generation Substrates with Engraved Patterns and Through Holes  
Envisiontec rapid prototyped finger shaped example of square pattern used to separate the conductive areas of the rapid prototyped finger shaped pad E-Shell 100 resin  
2008  
© Leon B M Williams

Centre for Jewellery Research,  
Royal College of Art, London

The Envision-tech rapid prototyping machine supported three different resins that could easily be identified by their colour and opacity. Clear, black, or flesh-coloured resins were used on the curved test samples. The flesh-colour resins shown in Figs. 61 and 62 were the first set to be made and were then later substituted with the black equivalent. Fig. 63 shows the samples after the plating process. A further flash plating of gold was selectively applied to the samples, to reduce oxidation forming on the wire pattern.

RESULTS DEMONSTRATING THE OPTIMUM SPACING OF ELECTRICALLY CONDUCTIVE PLATELETS MOUNTED THROUGH AND ON A CURVED SURFACES

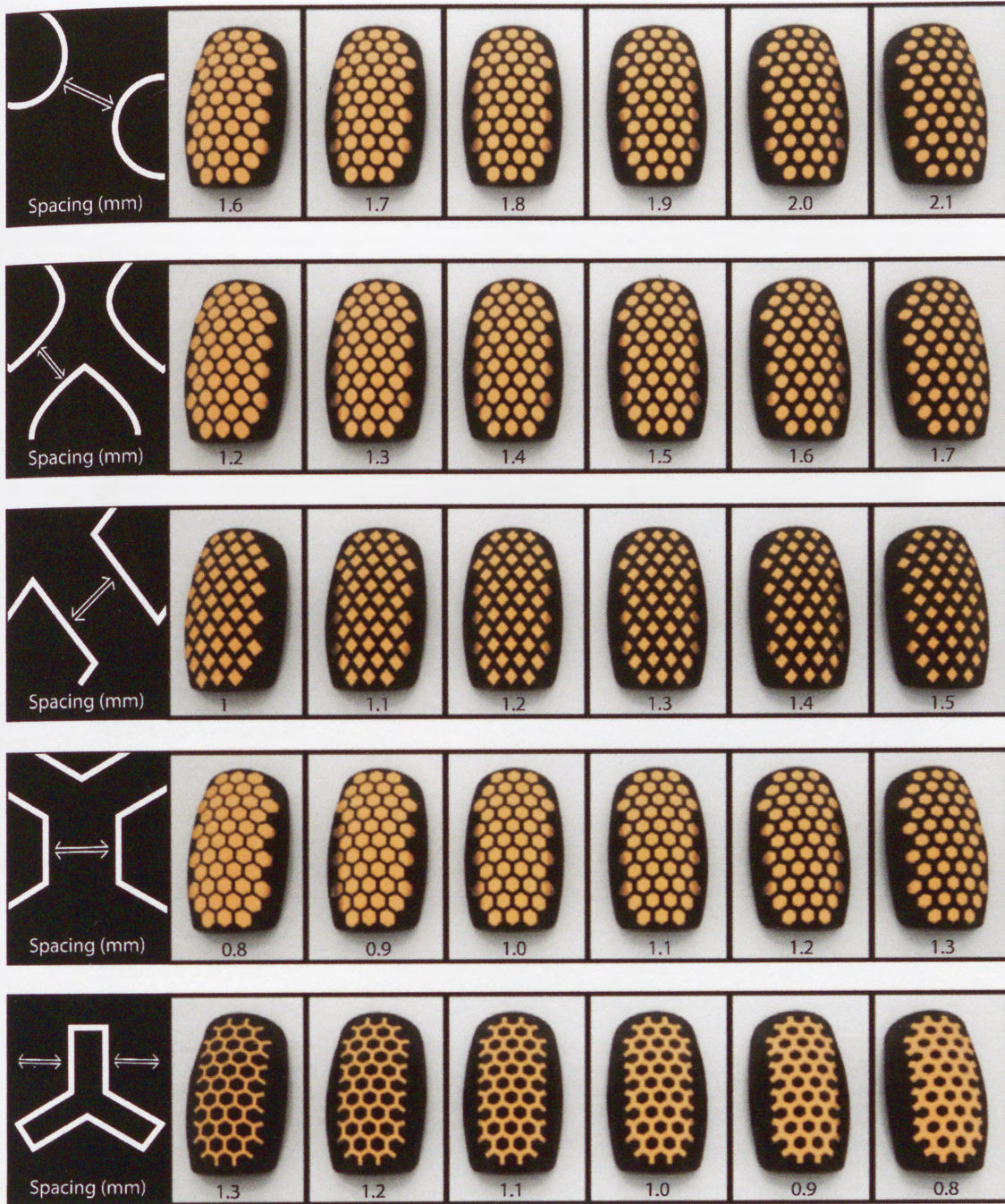

All simulation Touch Pads shown here detail the necessary parameters to achieve highly conductive imagery on curved surfaces. Each simulation demonstrates a selection of image based possibilities for use on simple jewellery forms. The gold platelets run parallel on both opposing sides of the heat resistant polymer. Each example shows the spacing requirements between two adjacent gold platelets to achieve optimum sensitivity and least resistance to the nearby component. For instance, rigid platelets require less spacing in comparison to the more circular alternatives - meaning that a tighter wire image can be achieved if the results shown here are correctly considered.



<< **Fig. 63 (Previous Page)**

Results Demonstrating the Optimum Spacing of Electrically Conductive Platelets Mounted Through and on Curved Surfaces,  
2008  
© Leon B M Williams

Centre for Jewellery Research,  
Royal College of Art, London

If the wire is too thin or the pattern too complex then there is a greater risk of sensitivity failure in the circuit. Table 3 details the limitation of the newly-used processes developed as part of this research.

**TABLE 3: TECHNICAL SPECIFICATIONS FOR CONDUCTIVE IMAGERY LIMITATIONS ON CURVED SURFACES**

<b>Capability:</b>	Free-Form Multi-layer
<b>Board Multilayer:</b>	Up to 4 Layers
<b>Board Profiling:</b>	CNC Routing CNC Score Legends & Mounting Locators Blank Piercing
<b>Minimum PWB trace width:</b>	4 thou holes
<b>Minimum Track spacing:</b>	4 – 8 mm
<b>Smallest drilled hole:</b>	0.35mm
<b>Largest drilled hole:</b>	1.8mm
<b>Material Thickness:</b>	0.35mm-6.4mm
<b>Plating Thickness:</b>	Up to 6 oz Copper or Nickel-Gold
<b>Max module size:</b>	26.0 mm x 18.0mm (including Legends)
<b>Max board layout size:</b>	500 mm x 400mm
<b>Standard Surface Finish:</b>	Hot Air Solder Level
<b>Min Loose End Finishing:</b>	0.25mm
<b>Alternative Finishes:</b>	Electroless Nickel / Immersion Gold Silver Electroless Tin Lead Hard Gold ( edge contact ) Carbon Peelable
<b>Bare Board Test (Audit)</b>	Flying Probe Test Simulation
<b>Solder mask:</b>	Photo-imageable Resist (wide range of colours)
<b>Gold plate:</b>	Edge Connectors , Touch Pads

Fig. 64 shows how conductive imagery could be used to fabricate detailed conductive imagery on rounded jewellery surfaces.

## CONDUCTIVE IMAGERY FOR USE WITHIN JEWELLERY APPLICATIONS



standard platelets



wire & platelets combination



linear wires



structural



wire mesh



rough plating



fine platelets



platted panels



raised panels



organic



detailed single plate



floating platelets

Each simulation details an interwoven matrix of conductive gold panels, wire imagery and interlocking parts designed to pass through and on a non-organic heat resistant polymer form. A single wire, platelet or panel can span a distance anywhere between 0.8 to 5.5 mm with at least 1.2mm minimum separating each conductive element to allow for sufficient electrical connection. To clarify, the variations shown here are based on the BABY-BLUE (GSR) Touch Technology - outlined in the previous chapter. Each simulation has been carefully chosen to demonstrate some of the endless possibilities of using conductive imagery as part of many digital jewellery applications in the future.

<< **Fig. 64** (Previous Page)

Conductive Imagery for use within Jewellery

Applications

2008

© Leon B M Williams

Centre for Jewellery Research,  
Royal College of Art, London

If applied correctly, the conductive patterns could be connected to separate pins on a PIC - meaning that different areas of the conductive image could be programmed to perform different functions on demand: the programmer of the BABY-BLUE jewellery is then given more freedom to turn parts of the conductive image on or off when required; two devices with corresponding image patterns could interface and pass an electrical charge through the conductive wire patterns. This would provide charging capabilities without the need for physically removing and replacing batteries.

## ENCLOSED JEWELLERY

*-Development of Circuit Imagery on Enclosed Objects-*

There are many constraints placed upon the designer when developing digital jewellery. One of the most difficult issues is trying to allocate enough space within the jewellery for the circuit and lithium battery without compromising the form of the jewellery. In addition, the circuit footprint (using the process developed) can change, along with the surface, however the lithium-ion rechargeable batteries cannot, as they are distributed in set package sizes. The design, and test models in Figs. 65 and 66 show one method of fitting all the necessary components into an enclosed jewellery form. Although these test examples did not retain any obvious jewellery qualities at this stage, elements were introduced as the technology was refined which would make the transition into a jewellery form more possible. The technology determines attributes like size, weight and volume of the jewellery, and thus affects the overall shape.



**Fig. 65**  
Bangle Simulation Detailing the Interlocking Substrate Layers.  
The exploded view shows all the parts that make up the bangle  
before rapid prototyping  
2008  
© Leon B M Williams

Centre for Jewellery Research,  
Royal College of Art, London

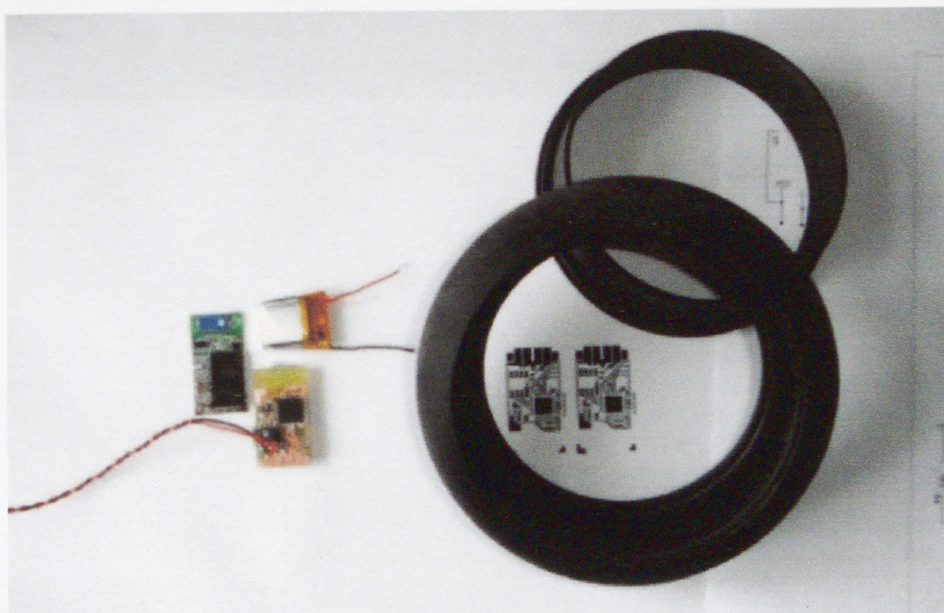

**Fig. 66**  
First Generation Bangle  
Black resin and electronic parts, before plating  
2008  
© Leon B M Williams

Centre for Jewellery Research,  
Royal College of Art, London

Examples in Figs. 67 and 68 show the outer rapid prototyped bangle, once plated and finished, could then be soldered to the circuit board and battery resulting in a clean and highly effective touch sensitive jewellery form. The bangle was programmed to sense body vibration and sweat.



**Fig. 67**

First Generation BABY-BLUE Pedometer Bangle Design. BABY-BLUE (PB) for short (*design simulation*) after Plating and Finishing Process.

Black Resin bangle with gold circuit imagery inlay and electronic parts. The gold detailing makes up part of a working touch sensitive circuit.

2008

© Leon B M Williams

Centre for Jewellery Research,  
Royal College of Art, London

The BABY-BLUE PB was designed to detect vibration. To ensure that the inner working did not interfere with its mechanical movements, all the components were tightly fixed inside the wall of the bangle form. The circuit board and battery therefore remains tightly fixed to avoid

unnecessary movement influencing the performance of the BABY-BLUE circuit. The next advancement made was to devise a suitable technology that could be used as a slider on single or multiple surfaces.



**Fig. 68**

Second Generation Bangles (*design simulations*) after plating and finishing process.

Black Resin bangle with gold circuit imagery inlay and electronic parts. The various gold detailing makes up part of a working touch sensitive circuit

2008

© Leon B M Williams

Centre for Jewellery Research,  
Royal College of Art, London

One advantage is all electrical connections were made through grooves formed or through holes in the jewellery. The rapid formed parts of the jewellery have a tolerance wall thickness of no more than 0.05+/- mm throughout the piece to maintain consistency and to avoid weak points in the jewellery. Combining all new processes involves blending traditional two-dimensional printed wiring fabrication with freeform printed wiring board processes using rapid prototyping technologies.

## MORE COMPLEX MEDICATION CARRIERS

*-Developing Complex Jewellery Forms for Carrying Different Types of Medications-*

This research has been positioned in the field of Goldsmithing, Silversmithing, Metalwork and Jewellery, at the Royal College of Art, yet is beneficial to the field of medical product design. The design shown in Fig. 69 with complex pomander form can be used to carry different pill types along with the BABY-BLUE technology.

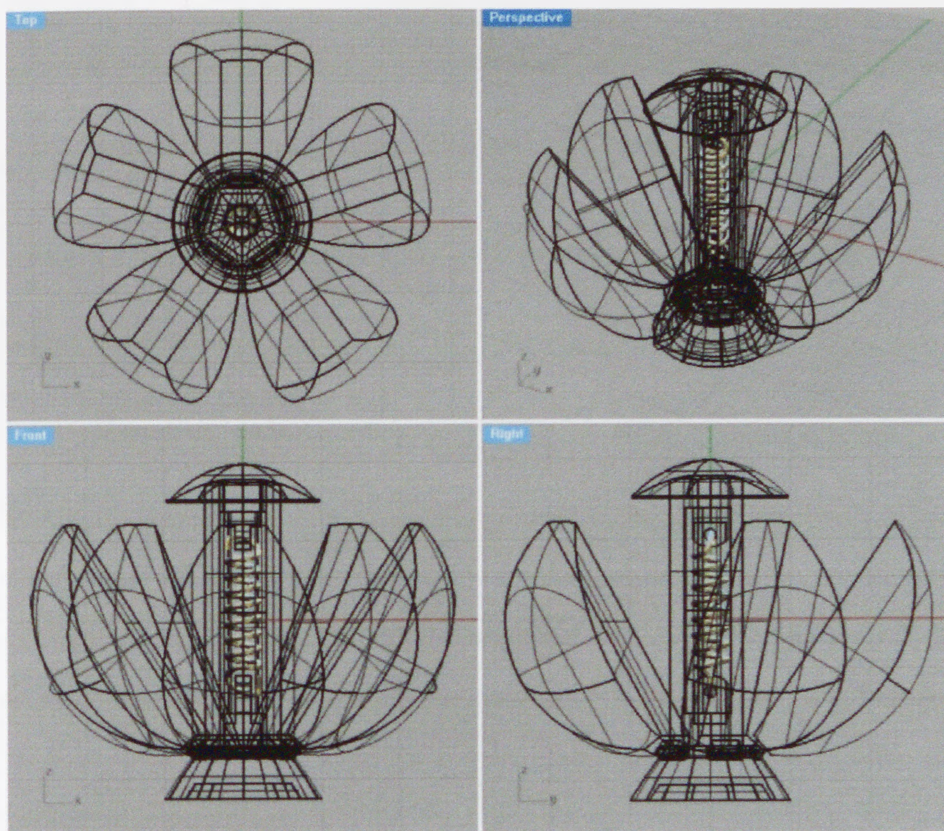

**Fig. 69**

First Generation Pill-Pomander Design  
Virtual design in Rhino3D, developed to hold  
and carry tablet medication within each  
compartment.

2008

© Leon B M Williams

Centre for Jewellery Research,  
Royal College of Art, London



One key objective of this research was to demonstrate the value of using jewellery to carry medicine that would help control the symptoms of medical conditions and improve user acceptance and interaction with the product.

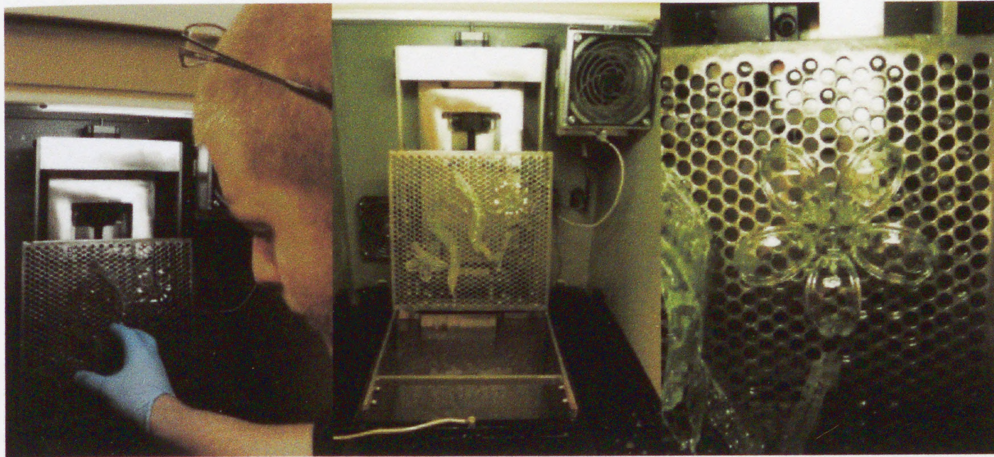

**Fig. 70**

First Generation Pill-Pomander Design  
Rapid-prototype  
Resin

The three photographs show the removal of the pomander directly after rapid prototyping. Once removed from the machine bed, the pomander is cleaned and then left to harden under ultra-violet light for approximately 30-45 minutes.

2008

© Leon B M Williams

Centre for Jewellery Research,  
Royal College of Art, London

A single sensory module worn like jewellery could discreetly monitor, collect and wirelessly transmit personal information about the user's body or medication. Multiple sensors (in separate items of jewellery) could be used together or apart— meaning that several sensory features would remain inactive until they were worn or touched, and the patient would have the choice of selecting and refining their monitoring needs. Control is given to the patient as to what information is being sent on the demand of the patient. In addition, the device would remind the patient to take their medicine appropriately and so maintain good treatment practise, which contributes to a healthy quality of life.



Fig. 71 (a)



Fig. 71 (b)

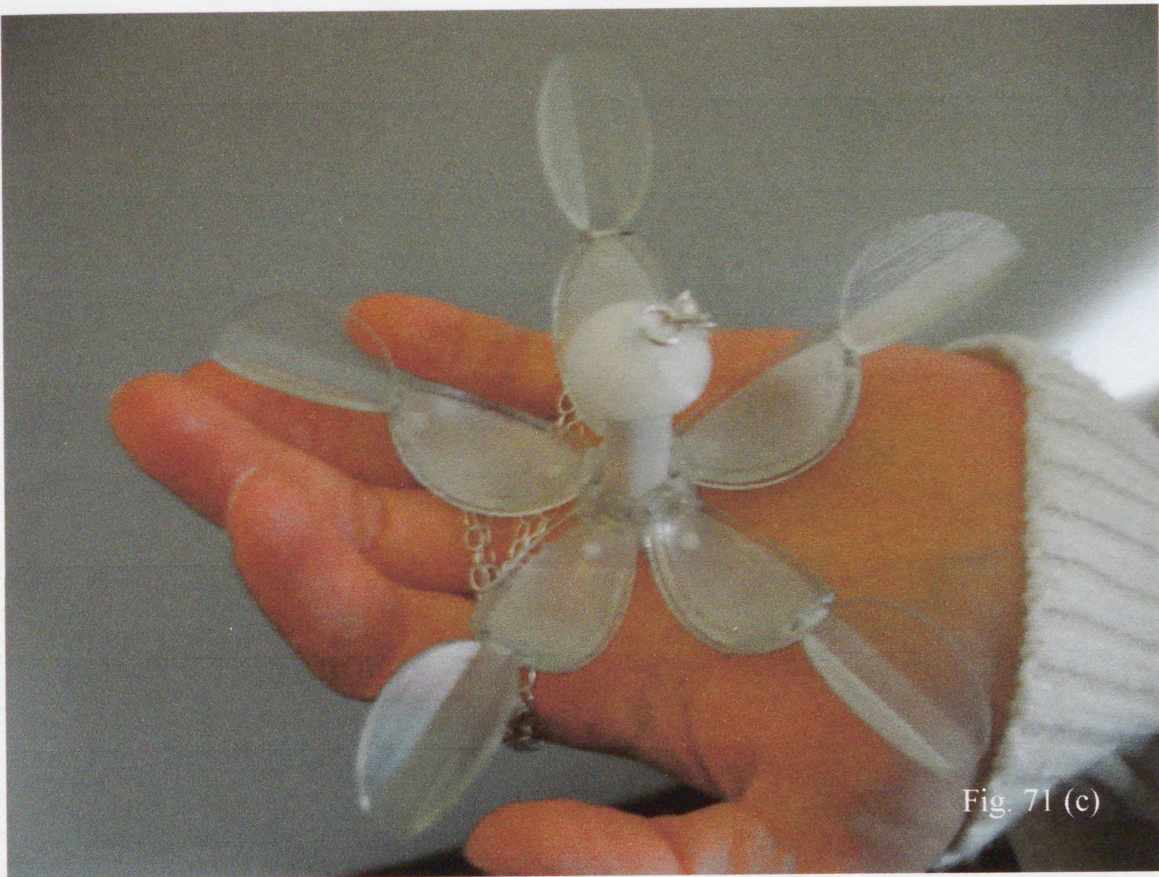

Fig. 71 (c)



Fig. 71 (d)



Fig. 71 (e)

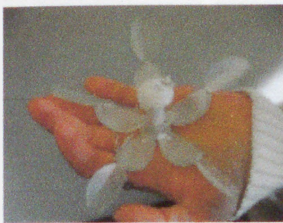

(f).



(g).



(h).



(i).

**Fig. 71**

Images a. through i. Show the Assembly of the Second Generation Pill Pomander Design.

Resin pomander with steel pin joints on a long silver chain

The pomander is demonstrated here by a researcher. The pomander is designed to hold 5 tablets of various sizes and could be used as a discreet way of concealing a patient's medication.

2008

© Leon B M Williams

Centre for Jewellery Research,  
Royal College of Art, London



**Fig. 72**

Third Generation Interchangeable Pill-Pomander  
Gold with Black Resin Panels

*(design simulation)*

The pill pomander is developed to carry different pill types. The wearer is given the ability to change different covers – making the pill-pomander practical for long-term use.

2008

© Leon B M Williams

Centre for Jewellery Research,  
Royal College of Art, London

All inventions developed as part of this research are made small enough to be worn on the body as jewellery, but large enough to be used as medical aides. The performance of each invention is of major importance and should be reliable in measuring accurate readings from the body through the non-invasive act of touch in a safe and practical manner. In addition, all collected data must be made accessible to the patient or physician for diagnostic purposes. This could be achieved through the development of a supporting software application which would make best use of the data.

## DEMANDS TO IMPROVE THE SELF-CARE DEVICE

- *The Effective use of BABY-BLUE Jewellery* -

The National Health Service (NHS)<sup>28</sup> distributes many different products that have common design-inhibitory problems. An example of this is the handheld Asthma Inhaler (for asthmatics, emphysema and bronchitis sufferers), a well-used functional item, which has utilitarian design features. Having been little modified since it was first distributed, it stands in contrast to many commercial products of the same period that have been altered beyond recognition to improve user interaction. The medical conditions of diabetes, asthma, and HIV were used as case studies to utilise the bio-sensory jewellery developed earlier within the research, and to improve the management of diabetes, asthma, and HIV, by developing products specifically related to those medical conditions. *So how will BABY-BLUE jewellery work with other devices?* BABY-BLUE technology was designed to support other portable personal assistant devices such as an insulin delivery device, which is also capable of performing various peripheral parameter checks of the patient's condition. The bio-sensory jewellery omits the use of universal serial bus connections, using inbuilt BABY-BLUE wireless transceiver and receiver technology to make this possible. The secure digital memory cards make the transition of data between different items easy. The introduction of an interchangeable element allows for the patient to activate different features of various bio-sensors, depending on the occasion or activity that is to be supported and monitored.

---

<sup>28</sup> UK Medicines Information, (2004) *Medicines Supply Problems* [online], NHS UKMI, [http://www.ukmi.nhs.uk/med\\_info/medsupprobs.asp](http://www.ukmi.nhs.uk/med_info/medsupprobs.asp) [Accessed October 2004]

## CONDUCTIVE GEMSTONES

*-Developing a Universal Charging Mechanism -*

Although the efficiency of the modules' was partly compromised, the decision was made to re-develop the BABYBLUE-GSR circuit board and touch pad with the aim to develop a device that could recharge its internal lithium-polymer battery without the need to open the jewellery manually. Due to the compact size of BABY-BLUE jewellery and to avoid large openings in the jewellery for cable connectors, it became necessary to develop a more elegant and less invasive solution for charging the jewellery. One successful solution was to integrate silver or gold plugs, cut like gemstones. When mounted on the surface of the jewellery, the plug would create an electrical bridge between the inner parts of the jewellery and its outer casing, allowing for a seamless, clean and cable-free method of charging.

To prevent short fusing, a programmable integrated component has been used to operate like a switch, allowing an electrical connection to pass to the main circuit board only if a consistent 3.7 voltage supply is detected via specific wiring on the surface of the jewellery. This means that the battery will not interfere directly with the touch sensor when the user is wearing the jewellery.

The aim was to utilize 'stones' made of silver conductive plugs that could be easily inserted and fixed into pre-drilled holes of the object, making it



possible for an electric connection to pass between two circuits held in two different but adjacent devices. Like the charger, all BABY-BLUE modules need additional protection to ensure that the surface is not scratched or damaged when charging.

Each 'stone' type was produced in one of two ways, depending on its crown size and the overall height. If the 'stone' had a crown diameter greater than 1.5mm with a height above 7mm, a casting process would be employed. However, if the crown of the gemstone was smaller than 1.5mm in diameter with an height less than 7mm a CNC milling process would be applied – this would retain the cleanest faceted appearance of the 'stone', which would otherwise be lost in the finishing of a casting. Of the many virtual gemstones a select few were either cast or CNC milled for trial testing on conductivity and usability, as shown in the following diagram:

**Fig. 73 (Next Page) >>**

Conductive Gemstones (brilliant cut) for Use in Jewellery Applications  
2008

© Leon B M Williams

Centre for Jewellery Research,  
Royal College of Art, London

# CONDUCTIVE 'GEMSTONES' FOR USE IN JEWELLERY APPLICATIONS

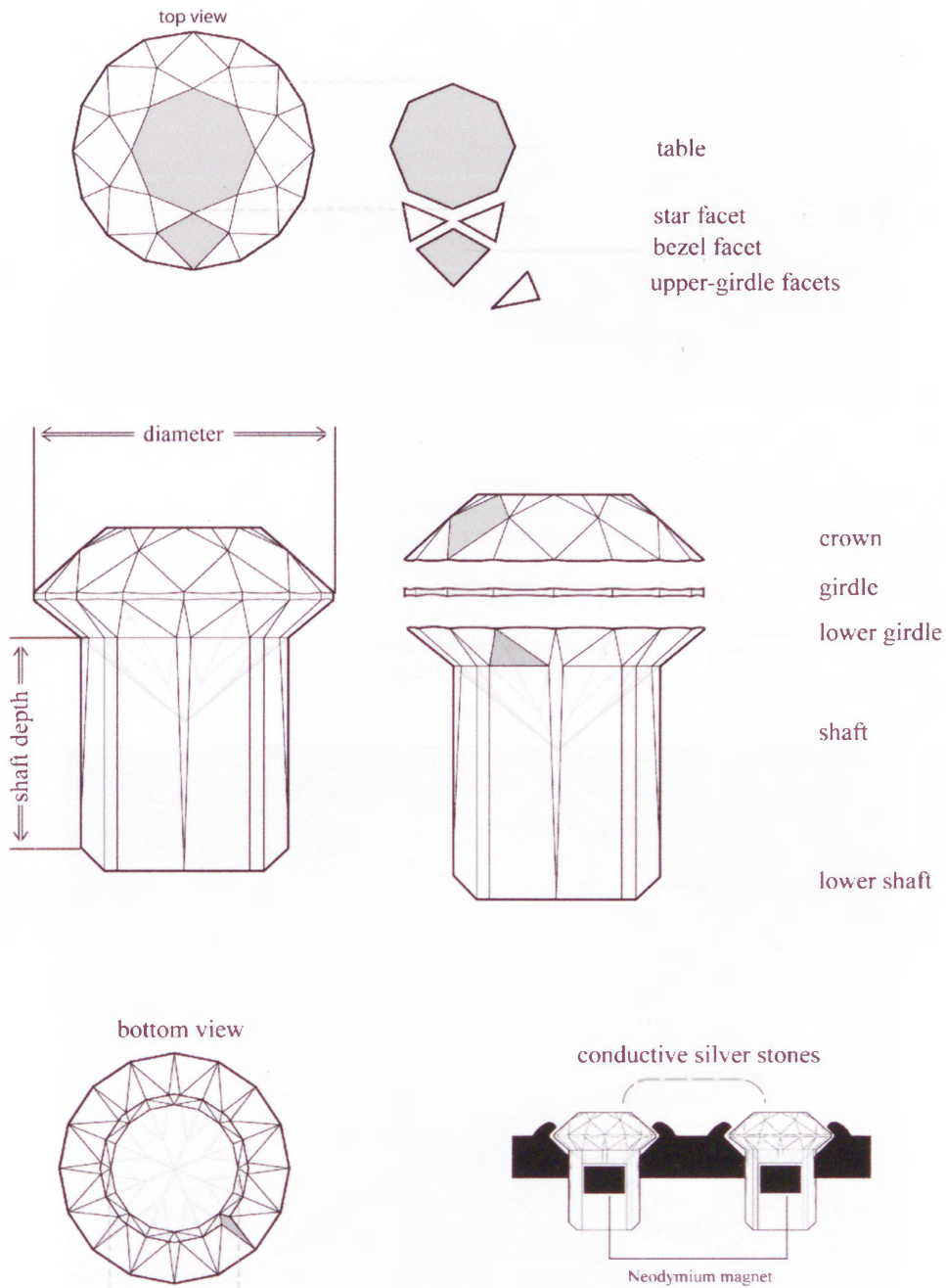

When the flat surfaces that make up the 'table', 'crown' and 'girdle' on two adjacent stones are simultaneously touched, an electrical circuit is able to pass between them. The 'lower girdle' and 'shaft' hold and support the stone whilst allowing an electrical circuit to pass through a substrate board or shell, bridging two opposing circuits running on either sides.



**Fig. 74**

Wax Gemstones (ready for casting into silver)  
The wax gemstones make up part of the conductive circuit that will be later used in digital jewellery.  
2008  
© Leon B M Williams

Centre for Jewellery Research,  
Royal College of Art, London

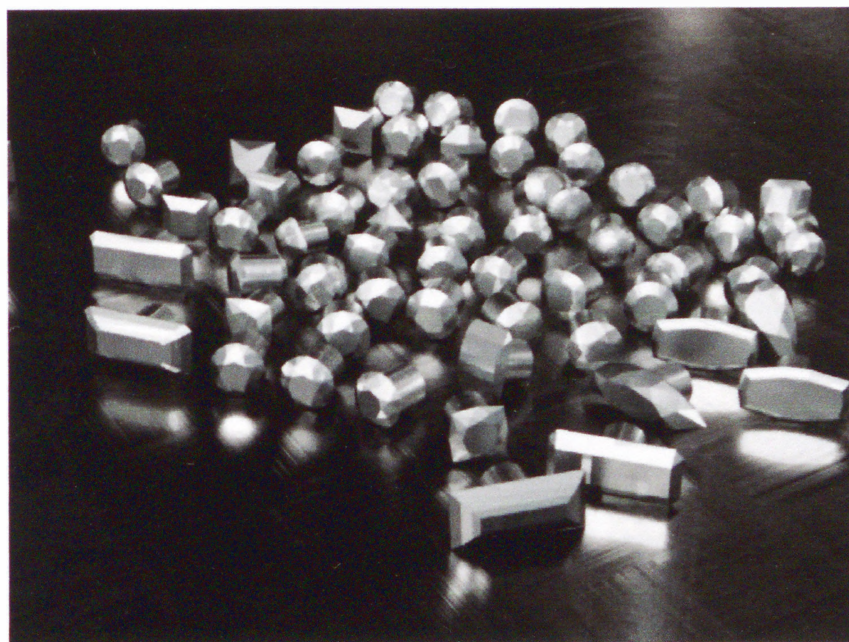

**Fig. 75**

Conductive Gemstones (after casting and polishing)  
The silver gemstones make up part of the conductive circuit that will be later used in digital jewellery.  
2008  
© Leon B M Williams

Centre for Jewellery Research,  
Royal College of Art, London

Tests revealed that clusters of conductive gemstones embedded over, on, or through multiple surfaces were most effective in protecting delicate wire patterns, but at the same time made them more difficult to touch and use. In addition, the gaps created for stone mounting made the jewellery less hygienic and vulnerable to dust or debris. This, over time, could possibly interfere with the performance of sensors and become difficult to sterilise. Finally, if conductive gemstones were mounted too closely together they could snag against loose clothing, damage circuitry or sensor and lead to unnecessary discomfort for the wearer.

It is common for anyone wearing jewellery to knock, bang, or scratch it. For this reason it is important to use practical materials so as to avoid damage to the jewellery and the BABY-BLUE module. So, in pursuit of a suitable replacement for the touch pad, the research needed to focus on the fabrication of a water resistant, durable shell that would best reflect the needs of the patient whilst being robust enough for constant wearing, and be convincing in appearance as an item of jewellery. The decision was made to develop new board variations to replace the rectangular model.

## PORTABLE BABY-BLUE CHARGER

*-Developing a Portable Charging Device-*

All electronic devices made today, including the BABY-BLUE GSR module, require regular recharging. Most portable chargers are bulky and impractical for carrying on the body as they need to be located near, and plugged into, a mains supply to recharge. The invention detailed here demonstrates an alternative. It runs from any laptop (with a standard usb connection) making it compatible on a worldwide scale. Although the device was designed in response to the needs of the BABY-BLUE module, it could also be used with any 3.7v dependent device.

Fig. 76 demonstrates a new portable device that can be re-charged and carried as a separate power source. Integrated Neodymium magnets line the surface of the charger and make it possible to transfer power to its surface, on command. This is achieved by the selective placement of magnets which repel or attract other surfaces with opposing magnets. When they are locked together, a tight connection is made which triggers a response in the device, and activates the charge through select conductive magnetic structures. This means that jewellery of varying sizes and shapes could be charged more freely and easily, without the constant need to be plugged into the mains power supply.

## CHARGE-CARD INVENTION FOR USE WITH BABY-BLUE MODULES

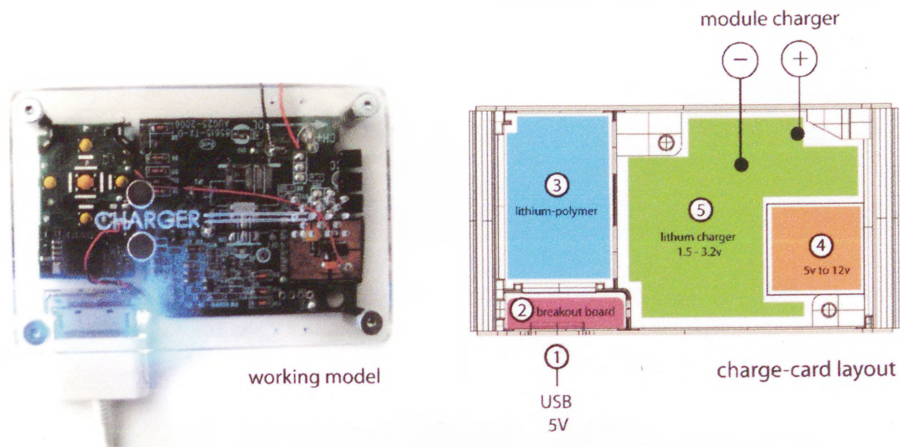

Charge-card (L:99 X W:53 X H:6.5mm) is designed to work with any BABY-BLUE module. The invention provides additional charging capabilities where a power supply is not available. Icons 1 to 5 on the layout (left image) detail the flow of power through each consecutive circuit board. Parts 3 and 5 are configured parts from other circuit boards as parts 2 and 4 are newly developed. When combined and programmed they form the basis for a universal charger that could be used to power any standard 3.7v device.

**Fig. 76**

Charge-Card Invention for use with BABY-BLUE Modules

2007

© Leon B M Williams

Centre for Jewellery Research,  
Royal College of Art, London

It was necessary to ensure the charger was easy to use, portable and adaptable and could be used as a hub or docking unit for easy accessibility in the home or at work. The first generation BABY-BLUE recharger invention was assembled from an assortment of new and existing circuitry.

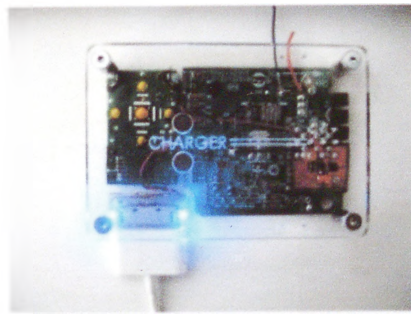

1. Power charge-card for a period of 30 minutes



2. Select the module to charge

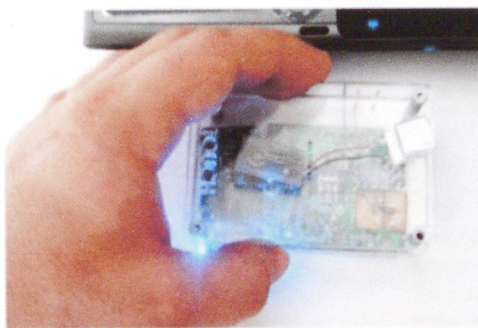

3. Remove charger from laptop and position the module on top of the charger

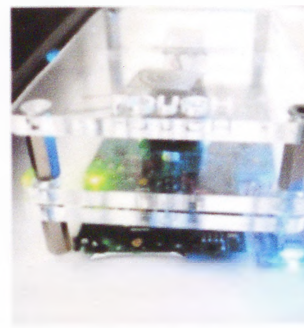

4. Charge module for a period of 5 minutes as indicated

**Fig. 77**

Photographic Sequence Detailing the Assembly of the BABY-BLUE Charge-Card Invention, 2007

© Leon B M Williams

Centre for Jewellery Research,  
Royal College of Art, London

The charger was trialled with success but one drawback of the first generation invention was that it only allowed for one module of a specific size to charge at a given time. This problem was later resolved by embedding a grid of smaller magnets throughout the casing surface. Fig. 78 demonstrates the addition of multiple magnets:

UNIVERSAL CARD-CHARGER WITH INTERGRATED NEODYMIUM MAGNETS

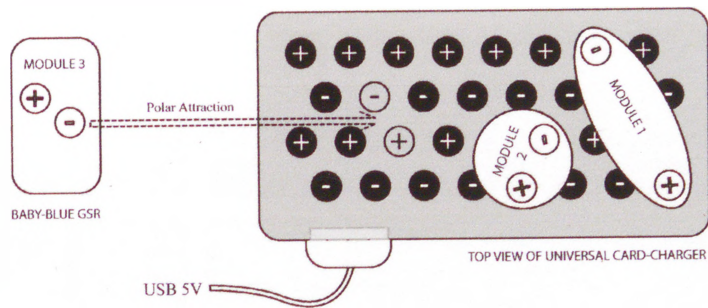

The module and charger are magnetically drawn together. Each Neodymium magnet should be between 1 and 3mm in diameter with a thickness of no more than 1mm. This will allow for a performance to range between 5900 and 2,000 Gauss (unit of magnetic induction, influenced by material and size) able to support a steel weight anywhere between 40gms and 0.2kgs. If the magnets are too small and weak they will not hold a tight enough connection, and if the magnets are too large and strong the module and charger will slam together risking the possibility of trapping the fingers or shattering both parts on impact. The diagram demonstrates different module sizes all with different magnet spacing. The intent is to allow for many modules to charge at one given time in different positions on the flat surface.

**Fig. 78**

Second Generation Universal Card-Charger Design

Illustrator design showing the arrangement of neodymium magnets on the charger surface. When the modules are placed in contact with the charger surface, parts of the electrical circuit become attracted to select parts on the charger 2007

© Leon B M Williams

Centre for Jewellery Research,  
Royal College of Art, London

The second generation charger proved successful in storing power from a nearby laptop and in transferring power to the BABY-BLUE GSR module. The next design focused on refinement of the case surface. The aim was to protect the embedded magnetic layer from damage whilst maintaining the conductive surface this would be achieved by enclosing it beneath another conductive surface, to improve its strength and appearance. Fig. 79 shows a selection of transparency image patterns ready for circuit printing and designed as part of the card-charger.



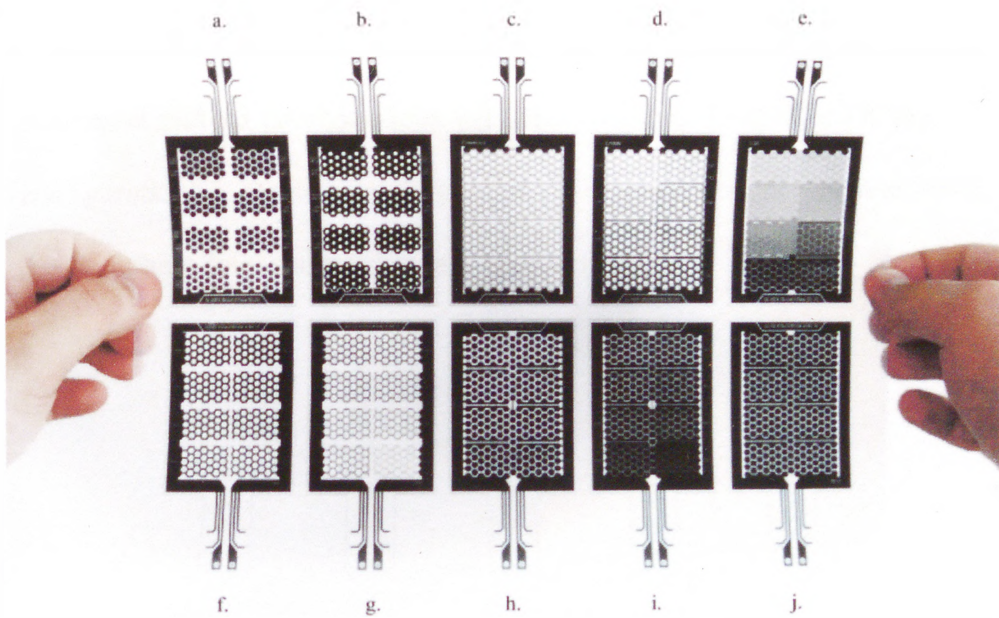

**Fig. 79**

(a. through j.) Shows Ten Hexagonal Imagery Patterns used to Etch the Surface of a BABY-BLUE Charge-Card.

2007

© Leon B M Williams

Centre for Jewellery Research,  
Royal College of Art, London

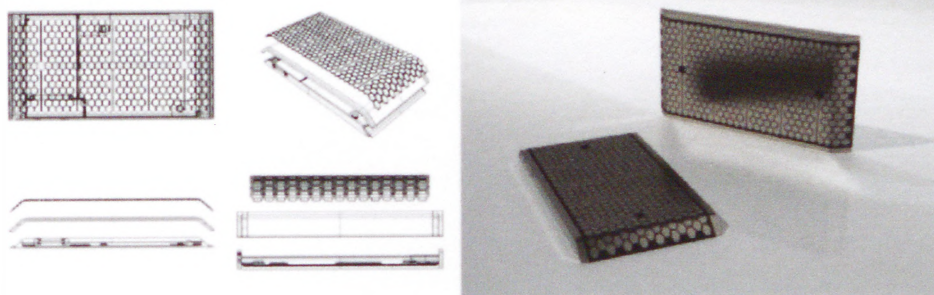

**Fig. 80**

CAD Exploded Diagram and 3-Dimensional Simulation of the BABY-BLUE Card-Charger with Conductive Hexagonal Wire Pattern.

2007

© Leon B M Williams

Centre for Jewellery Research,  
Royal College of Art, London

For etching different protective surfaces more than one hundred pattern combinations were designed. These were narrowed down to ten of the most successful pattern configurations (as shown in Fig. 79 & 80). Of the ten configurations a. through to j. - pattern i. was chosen as the most suitable design to best demonstrate charging capabilities.

## BRIEF INTRODUCTION TO THE THREE CASE STUDIES

*-The Patient and Physician-*

It is certain that to improve the synergy between object and wearer, the patient must have the ability to exercise control - a point of view shared by many medical experts today. For instance, Professor Martyn Partridge (2003) states: "*We know that by giving control for managing a long term condition such as asthma to patients results in the best outcome for them*".<sup>29</sup> From ownership to self-responsibility, the patient, when wearing and using jewellery of this kind, could not only acquire a better understanding of the body, but also show less resistance to the use of a medical aid. Its 'character' or appearance of jewellery could make it inherently more acceptable when used about the home or at work, thus improving the patient's quality of life, whilst creating pleasure out of necessity.

---

<sup>29</sup> Interview and Questionnaire Conducted by Leon. B. M. Williams – 2003

The Development of Digital Technologies for  
Use in Jewellery with Medical Applications

LEON B. M. WILLIAMS

A thesis submitted in partial fulfilment of the  
requirements of the Royal College of Art for the  
degree of Doctor of Philosophy

**VOLUME II OF III**

April 2009

The Royal College of Art

CONTENTS  
**JEWELLERY AND MEDICINE**

**VOLUME I**

Copyright Statement, Abstract, *Contents*, List of Tables, List of Illustrations, Acknowledgments, Authors Declaration, Definitions, Acronyms and Terms, Jewellery and Craft

2

**INTRODUCTION**

Motivation, Methodology, Focus Groups

25

**THE HISTORY OF MEDICAL JEWELLERY**

Healing Jewellery, The Digital Age, A Look to the Future, Consultation with the TABPI

37

**BABY-BLUE GSR MODULE**

The Future of Jewellery and Medicine, Touch Sensitive Jewellery, BABY-BLUE Technology, The BABY-BLUE GSR Circuit, Programming the BABY-BLUE GSR Module, Integrating BLUE Tooth Technology, BABY-BLUE Test Trials, Conductive Circuit Imagery, Re-designing the BABY-BLUE Circuit Board

62

**TOUCH SENSITIVE JEWELLERY**

Fabricating Touch Slider Pads for Jewellery Applications, Curved Conductive Surface, Enclosed Jewellery, More Complex Medication Carriers, Demands to Improve the Self-Care Device, Conductive Gemstones, Portable BABY-BLUE Charger, Brief Introduction to the Three Case Studies

112

**VOLUME II**

**PROJECT ASTHMA**

History of Asthma, Metered Dose Inhalers, Developing a new Asthma Inhaler Mechanism, Summary

148

**PROJECT DIABETES**

The Beginnings of Diabetes Awareness, Patient Self-Care, Understanding Diabetes, Developing a New Home Glucose Measurement System (HGMS), A New Insulin Delivery System (IDS), A New Measurement Gauge, A New Safety Cap Design, The Development of the Disposable Needle Safety Guard, Preventing Needle Shift, Developing a Personalised Management Tool for the BABY-BLUE Software, Summary, Future Development

186

**PROJECT HUMAN IMMUNODEFICIENCY VIRUS**

Understanding the Various HIV Treatments, Developing a Pill Carrier, Developing a New Flexible Watch, Summary

242

**CONCLUSION**

Evaluation Phases, Research Methodology Review, Final Project Review, Consultations, Critical Reflection, Collaborative Research Thinking.

262

**VOLUME III**

Appendices A-F, Bibliography

277



# CHAPTER 4

**PROJECT ASTHMA**  
*Design Development*

149

**HISTORY OF ASTHMA**  
*Contextual Research*

150

**METERED DOSE INHALERS**  
*Inhaler Device used by Patients Today*

158

**DEVELOPING A NEW ASTHMA INHALER  
MECHANISM**  
*Better Patient Care*

163

**SUMMARY**  
*Overview of the New Slim-Line Inhaler*

182

## PROJECT ASTHMA

- Design Development -

This chapter focuses on the development of a new beta-2 agonist and steroid delivery system, by introducing features inherent to jewellery. First, the most significant milestones in history, that have influenced the development of asthma awareness are addressed, discussing how historical artefacts were used to help prevent or suppress the effects of asthma. Then the uses of current and new inhaler designs are discussed, focusing on the meter-dose inhaler mechanism. Finally, the research and designs focus on the potential of embedding jewellery characteristics to produce a new slim-line inhaler mechanism that could be used to support, carry, or administer aerosol medication for asthma patients in the future<sup>30</sup>.

Outcomes developed here are *not* intended to provide a definite solution for asthma patients however, they do offer an alternative way of thinking and creative practise aimed specifically at developers or craftsmen who are working towards the development of future pharmaceutical products.

---

<sup>30</sup> BBC News. (2004) *Asthma* [online], <http://news.bbc.co.uk/1/health/medical-notes/233033.stm> [Accessed 21 February 2005]

## HISTORY OF ASTHMA

*-Contextual Research-*

The Ebers Papyrus<sup>31</sup> contains over 700 remedies and prescriptions for numerous ailments. As it stands the Papyrus gives us the earliest known evidence of inhaled medicines being prescribed and used as a treatment. The extract from the Ebers papyrus shown in Fig. 81 describes the process of pulverising herbs, plants, fruits and vegetable agents to make a slushy paste. Ancient Egyptians believed that the smoke produced from the burning of such ingredients over hot bricks had medicinal properties and when inhaled through the hollow of a reed would rid the body of illness.



**Fig. 81**

Ebers Papyrus  
About 1550 BC (16<sup>th</sup> dynasty)  
Ancient Egypt  
One of the oldest preserved medical documents prescribing a mixture of herbs smoked over hot bricks so that the sufferer could inhale the fumes.

University College, London

The Ancient Greeks practised the art of Egyptian medicine. In the case of the inhalation treatment many ingredients were changed to simplify recipes, whilst charcoal and ceramic tubes replaced bricks and reeds to

<sup>31</sup> Bryan, C. P. (1930) *The Papyrus Ebers*, London: Garden City Press



make the inhalation process more effective. Even today compound medicines based on charcoal are being used to absorb toxins from the body. The next historical milestone for the inhalation treatment dates back to 450 BC, when the Greek philosopher and writer Hippocrates first referred to the word 'aazein'<sup>32</sup>, meaning 'a sharpness of breath'. He believed that his patients could be treated by means of purging the body of 'foul toxins' by using a method applied in Ancient Egypt. Furthermore, he speculated in his work that asthma is more likely to occur in people that are exposed to foul toxins or unpleasant fumes for prolonged periods of time.

Greek physician Claudius Galen in 1190<sup>33</sup> observed the effects of pungent particles being inhaled by his patients, which was followed by full bronchial constriction. Around the same time philosopher, physician and Rabbi, Moses Maimonides (1138-1204), also began to study 'triggers' of asthma<sup>34</sup>. His work predominantly focused on the prevention, diagnosis, and treatment of asthma, but it was physician Bernardino Ramazzini in the 17th century, who recognised the effects of organic dust<sup>35</sup> when inhaled by some of his asthmatic patients. It was then that the inhaler device began to make an appearance.

---

<sup>32</sup> Medisch Centrum voor Huisartsen (2006) *A Plea to Abandon Asthma as a Disease Concept* p. 59 [online], available from: <http://www.mcharts.be/artsen/Documenten/Tijdingen/wtsept06.pdf> [Accessed September 2007]

<sup>33</sup> Answers.com (2007) *History of Asthma* [online] <http://www.answers.com/topic/asthma> [Accessed December 2007]

<sup>34</sup> Heath Type (2007) *Asthma* [online] <http://www.healthype.com/category/asthma> [Accessed September 2007]

<sup>35</sup> Asthma and Allergy Foundation of America (2005) *Asthma - A Disease of Antiquity* [online] [http://www.aafa-ca.org/asthma\\_history.php](http://www.aafa-ca.org/asthma_history.php) [Accessed September 2007]

The earliest known multi-purpose inhaler was designed by Dr. John Mudges in 1778<sup>36</sup> and made of pewter. Artefacts of this type are rare and easily mistaken for drinking vessels, being identified only by the perforated lid opening, which allowed patients to draw steamed air to improve their breathing.



**Fig. 82**

The Mudge Inhaler

1778

England

Pewter mug-shaped inhaler with perforation over the cover opening

Wellcome Collection, London

Museum no. 765/66

---

<sup>36</sup> Anderson, P. MD (2005) 'A History of Aerosol Therapy', *Respiratory Care*, September 2005, vol 9, pp. 1140 - 1141

Many inventors took inspiration from Dr. John Mudge's work, such as Dr. Nelson<sup>37</sup>, who later developed a pear shaped upright model made of ceramic, glass and cork<sup>38</sup> in 1865. His improvements included air-inlets that increased the efficiency of air-flow and a separate glass mouthpiece designed to fit into a cork seal at its stem, to prevent organic dust from entering into the device. Dr. Nelson was renowned amongst leading physicians of the time. His vessel with its unique features and quirky design quickly became regarded as a revolutionary product in the field of medicine delivery systems, and was sold worldwide by S. Maw & Son of London<sup>39</sup> to pharmaceutical companies. Only a year later, in 1896, Maw & Son launched a new improved model with a "Double Valve" system<sup>40</sup>.

---

<sup>37</sup> Anderson, P. MD (2005) '*A History of Aerosol Therapy*', Respiratory Care, September 2005, vol 9, pp. 1140 - 1141

<sup>38</sup> Bygonz (2005) *A History of Inhaling* [online] <http://www.bygonz.co.uk/inhaler.htm> [Accessed June 2007]

<sup>39</sup> Richmond, L., Stevenson, J & Turton, A (2003) *The Pharmaceutical Industry*, Ashgate Publishing Ltd: Hampshire, pp. 246 - 248

<sup>40</sup> Bygonz (2005) *A History of Inhaling* [online] <http://www.bygonz.co.uk/inhaler.htm> [Accessed June 2007]

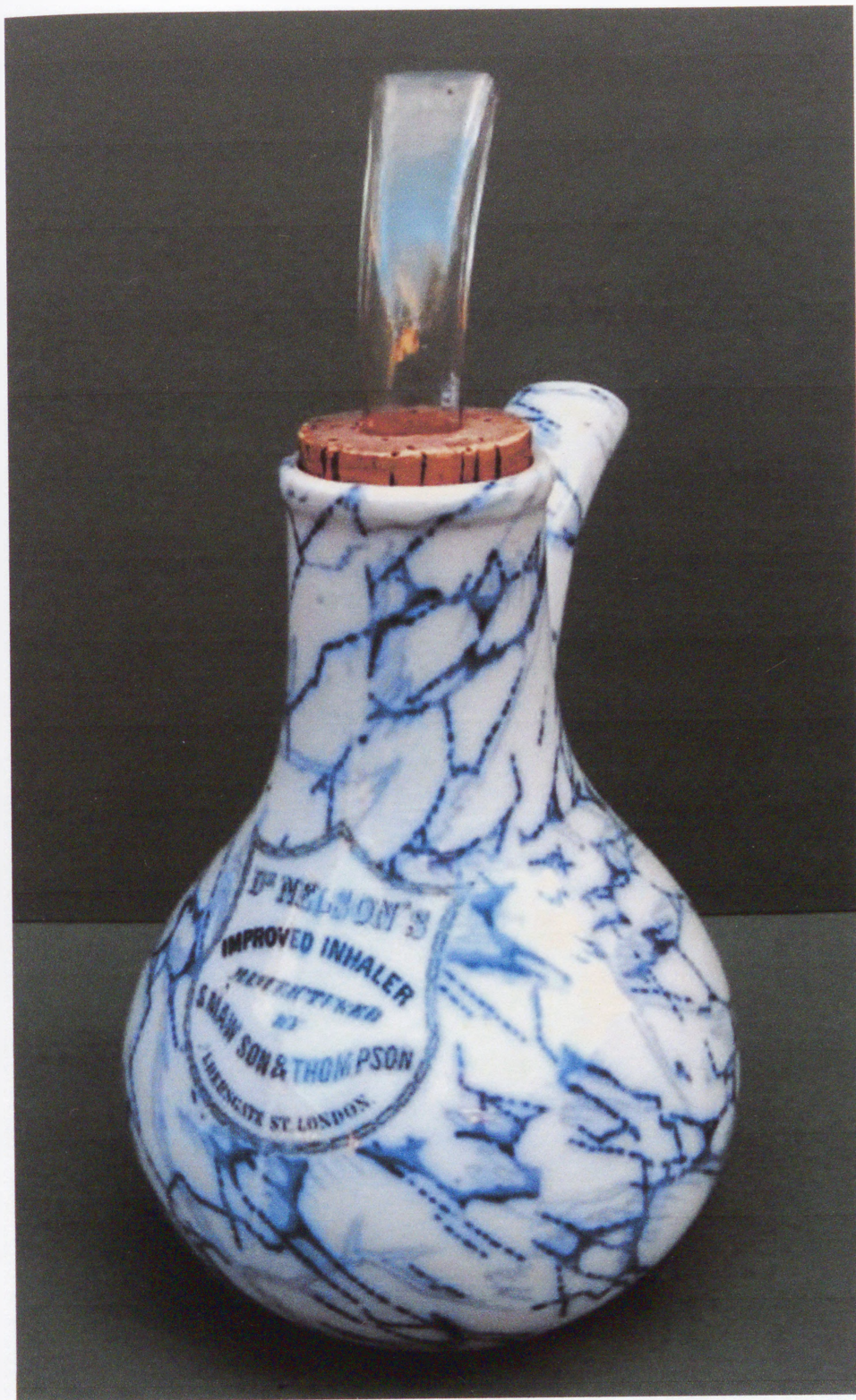

**Fig. 83**

Dr. Nelson's Improved Inhaler

About 1865

Marbled with Cork stopper

England

Made by S. Mawson and Thompson, Aldersgate St., London.

Still retains its glass spout.

Jon Fox Antiques, Medical, Pharmacy and Scientific  
Stock. no. 14576



**Fig. 84**

Victorian Inhaler named the 'Letheon' used as an Ether Anaesthesia

1847-1848

England

Brass, glass and fabric

by Weiss T Morton's of London

Science Museum Picture Library, London

Inv. no. A625399

Although many other rival companies were producing similar barrel shaped variations, they required a separate tube to draw in air, which made them cumbersome to handle and more complex to assemble. The early ether anaesthesia inhaler, named the 'Letheon', made in 1847-1848 by Weiss T Morton's of London<sup>41</sup>, showed another use for the double valve vessel with a successfully designed multi-functional application of the inhaler.

The Victorians and Edwardians developed many simplified versions of the inhaler to be used in a clinical setting, such as the the Sir Hiram Maxim's Pipe of Peace inhaler 1910.



**Fig. 85**  
Sir Hiram Maxim's Pipe of Peace and  
Maxim Inhaler  
1910  
Glass pipe corked at both ends and  
various cleaning implements

Science Museum Picture Library, London  
Making the Modern World Gallery  
Inv. no. A629585

<sup>41</sup> BTTC (2006) *Letheon Inhaler* [online] <http://www.general-anaesthesia.com/images/the-letheon.html>  
[Accessed June 2007]

Hiram Maxim (1840-1916) invented the Pipe of Peace<sup>42</sup> to treat his bouts of bronchitis. Ironically, Hiram also invented automatic fire arms (the machine gun). These two inventions were considered by his closest of friends as a contradiction in terms and a possible threat to his professional reputation. In fact, a friend ironically stated: *"It is a very creditable thing to invent a killing machine, and nothing less than a disgrace to invent an apparatus to prevent human suffering."*<sup>43</sup> By the perception of today though it seems unemotional to invent two such devices – one that saves lives, and another which takes lives.

Maxim's Pipe of Peace inhaler kits were sold in 1910 for home use, along with a single bottle of remedial agent. Asthma sufferers were (as a result of the portable inhaler) given for the first time the choice of treating the symptoms of asthma in the privacy of their own home, in part giving people the ability to take back an element of self-care that was otherwise unavailable.

---

<sup>42</sup> Arnold, K. & Olsen, D. eds. (2003) *Medicine Man, The forgotten museum of Henry Wellcome*, London: The British Museum Press, p. 357

<sup>43</sup> Brown, M. (1985) 100 years of 'Maxim's Killing Machine' *New York Times*, 26 November, [online], available from <http://www.nytimes.com/1985/11/26/science/100-years-of-maxim-s-killing-machine.html?&pagewanted=4> [Accessed June 2008]

## METERED DOSE INHALERS (MDIS)

*-Inhaler Device used by Patients Today-*

Metered-dose-inhalers (MDIs) are used in transporting and protecting many forms of drugs for asthma patients across the UK today. The inhaler is one of the most widely used and recognised medical devices worldwide. Even the modern equivalent produced today shares the same design footprint as Dr. Nelson's upright vessel inhaler of 1865. Since then, many inventions have come and gone, with each alteration providing a better and more efficient self-care delivery system, making the medication more freely accessible to millions of people.

By the mid 1960s, metered dose inhalers had become a standard device for home use. Inhalation medicine acted faster than the conventional tablet equivalent and required a lower dose overall. The small particles of medicine, between 1 and 7  $\mu\text{m}$  in diameter, gave almost instant relief and competent use of the inhaler mechanism became all the more valuable in the pursuit of the control of the effects of asthma. An MDI is the standard device for delivering aerosol medicines to the small airways for people suffering with asthma or chronic obstructive pulmonary disease (COPD). Asthma medicines are typically administered through inhalers (puffers) which control the symptoms of asthma. There are two main types of inhaler devices, known as 'preventers' and 'relievers', which contain different medicines, demanding two separate procedures.



Preventer inhalers come in brown, red or orange and are used to control the symptoms of asthma such as wheezing, breathlessness, tightening of the chest, and episodes of violent coughing. Preventer inhalers contain steroid medicine called corticosteroids that act like natural hormones produced in the body, and are designed to de-sensitise the affects of many symptom inducers such as pollution, pollen, animal hair, or smoky environments- all of which can trigger an asthma attack. Also, the medicine is most effective if used frequently (at least twice daily) as preventive medication even if there are no symptoms. The following list details the most commonly used types of metered dose inhalers developed to carry aerosol preventer medicines for the European market.



**Fig. 86**

Collection of Preventer Metered Dose Inhalers  
Designed to Support Aerosol Medication.  
2006-2008

Private Collection

Relievers come in blue, grey or green inhalers and are known in the medical community as beta-2 agonists. Beta-2 agonists contain two substances - 'adrenaline' and 'noradrenaline' - that are responsible for triggering a "fight or flight" reaction in the body, relaxing the muscles surrounding the airway and reducing the amount of mucus produced in the lungs, making it easier for the patient to breathe. Although Beta-2 agonists work quickly they do not reduce the inflammation in the airways. Typically, patients are advised to use a reliever inhaler prior to strenuous exercise, with the effects of the medicine lasting between 2-3 hours. The following list details the most commonly used types of metered dose inhalers developed to carry Aerosol reliever medicines for the European market.



**Fig. 87**

Collection of Reliever Metered Dose Inhalers  
2006-2008

Private Collection

Traditional preventer and reliever inhalers consist of three parts: the medicine canister, a plastic actuator and a protective cap. Medicine canisters are designed to attach to the inside of a plastic inhaler case, known as the 'actuator'. Most actuators are hand-operated, to release a measured dose of medicine when activated. There are two preferred medicine types: aerosol based inhalers and dry powder inhalers.

Dry Powder Inhalers (DPIs) are generally proprietary devices to administer treatment medicine. They are widely used as an alternative to the aerosol based inhalers and demand different procedures of use. For instance, powder medication can come in capsule form and is loaded in a hand-operated actuator. Most product designers tend to favour developing the dry powdered inhalers due to there being fewer restrictions, such as size of the canister. However, powder medicine is in practice more difficult to inhale, as the powder provokes a cough-like reflex. Breath-actuated metered dose inhalers (B-A MDIs) allow patients to prime a spring loaded trigger mechanism that encapsulates the canister. When the patient inhales and draws enough suction on the mouthpiece it activates the mechanism, forcing the canister to release a measured dose of medicine into the airway in time with the breathing. This mechanism is highly effective for mild sufferers of asthma, but triggering a puff of medication whilst breathing in air with these two inhaler types could prove difficult to co-ordinate. Typically children or adults with chronic asthma use a product known as a 'spacer device' as shown in Figs. 88 - 90.



**Fig. 88**  
Mother and Child are Learning how to use an Asthma Inhaler Device with Spacer and Face Mask. 2006  
Colour Photograph

[www.allergyasthma.wordpress.com](http://www.allergyasthma.wordpress.com)

**Fig. 89**  
Man using a Breathing Apparatus 2008  
Black and White Photograph

[www.breathela.org/portal/asthma](http://www.breathela.org/portal/asthma)

**Fig. 90**  
Elderly Lady using an Asthmatic Device 1999  
Colour Photograph

<http://news.bbc.co.uk/1/hi/health/288611/stm>

One major drawback of using a plastic spacer is that the patient can experience a loss in dose due to a build-up of electrostatic charge, which attracts the drug to the inner walls of the spacer. This can only be prevented with periodic cleaning. The advantage of using a spacer is that it distances the patient from the device and is less forceful when firing medicine into the mouth<sup>44</sup>.

---

<sup>44</sup> BBC News. (2004) *Asthma Patients Fear Fatal Attack* [online] <http://news.bbc.co.uk> [Accessed October 2007]

## DEVELOPING A NEW ASTHMA INHALER MECHANISM

*- Better Patient Care -*

Despite advances in the field of medicine there is no cure for asthma, making it a serious threat to people today. Until a cure is found, people with asthma rely upon the provision and availability of more and better delivery systems to help them control or suppress its symptoms - which is where medical jewellery can come into play. According to the Asthma UK research Audit, commissioned in 2004, more than 5.2 million people in the UK alone suffer from asthma, and experience some form of episode or 'attack'. This project proposed to research theories and practical technologies, whilst addressing the pragmatic advantages and disadvantages of various delivery devices.

The objective of this research is a more suitable and practical inhaler device that is capable of delivering beta-2 agonists and steroid medicines for patients with asthma. My aim as a maker is to produce a fully working product, with supported BABY-BLUE technologies and software. It should be practical and user friendly, with jewellery characteristics, to make taking medication more pleasurable and less of a burden. A participant was asked to explain the problems of using a typical inhaler mechanism with a spacer attachment. The main problems of using the inhaler and spacer devices were based on size and aesthetics.

PARTICIPANT SHOWING THE USE OF A TYPICAL  
ASTHMA INHALER AND SPACER ATTACHMENT

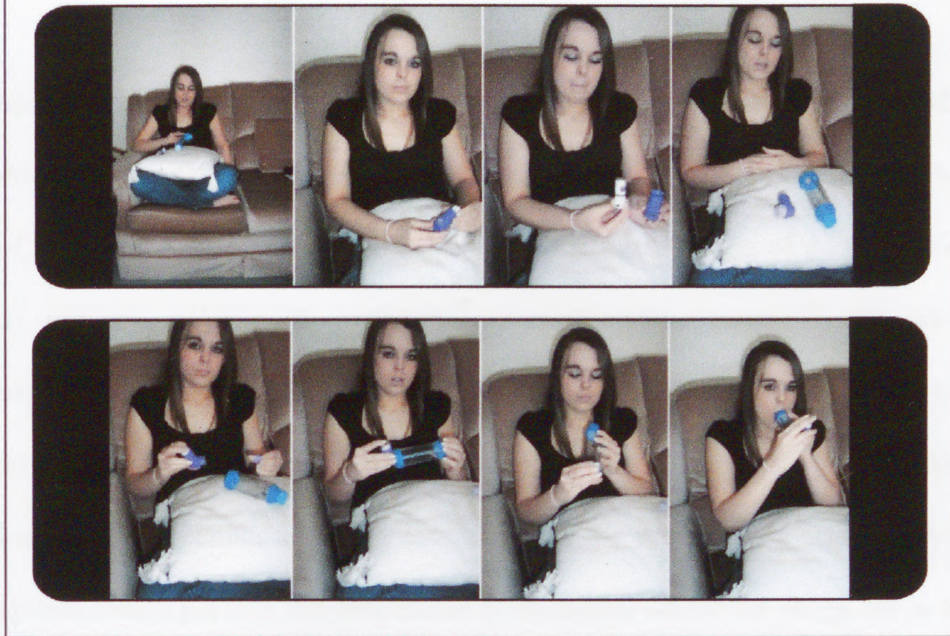

**Fig. 91**

© A Teenage Asthma Patient using a Meter  
Dose Inhaler and Spacer Attachment  
2008  
Leon B M Williams

Centre for Jewellery Research,  
Royal College of Art, London

Even though today most suffers tend to experience mild forms of asthma, there has over the past 20 years been a dramatic rise in the number of those suffering from the effects of the more permanent and severe forms. For such patients asthma can affect all aspects of their daily lives. Even the simplest of operations can be a struggle, from exercising and working in the mornings to socialising and travelling at night, while relying entirely upon the inhaler device to help maintain a good quality of life. Asthma is a condition where simple factors such as over-exercise, stress, illness, or heavy eating can result in an attack. So it should come as no surprise that it

is among one of the main causes of fatalities in the UK and Europe. Most patients with asthma have to manage and treat their symptoms as they occur, without the assistance or specialised care of a doctor or nurse.

Spacer add-ons can help to reduce the amount of corticosteroids needed, due to the prevention of medicines escaping from the mouth whilst in a state of transition. Children under the age of five require the use of a face mask to prevent leakage of medicine<sup>45</sup>. Economically, spacers<sup>46</sup> are less expensive and easier to maintain than nebulisers<sup>47</sup> and can reduce the risk of an overdose. Smaller, cheaper spacers exist but are regarded by many healthcare specialists as being less effective, as they usually use a valve system which permits the suspension of medicine whilst the drugs are in a transitional state between canister and mouth. However there is one research project that is taking the practice of cheap inexpensive design to the absolute edge: according to an online source entitled '*An extremely affordable device for better asthma care (better breathing with origami)*', doctors and healthcare experts in Mexico are practicing the art of origami to fold spacers, as shown in Fig. 92. These simple craft techniques

---

<sup>45</sup> Thorax (1997) '*Asthma in Adults and School Children*', *Thorax*, 52, Supplement 1, pp. 2-8

<sup>46</sup> Asthma UK (2005) '*Volumetric Spacer is Withdrawn*' Asthma UK, 30 August, [online], available from [http://www.asthma.org.uk/news\\_media/news/volumetric\\_spacer.html](http://www.asthma.org.uk/news_media/news/volumetric_spacer.html) [Accessed July 2007]

<sup>47</sup> Nebulisers are commonly used in a clinical setting like a hospital or surgery to give high doses of reliever medicine over long periods when a patient is experiencing a severe episode or attack. Face masks or mouthpieces are used to prevent medicine leakage, maximising the effectiveness of the medicine whilst relieving the patient from any mechanical duties. Most nebulisers today are used with beta2-agonists, cromolyn sodium, Anticholinergics. Although this is an effective means to deliver medicine to those who are ill or having an attack they are not very precise. If used incorrectly for a prolonged period of time the patient is at risk of an overdose <http://health.msn.com/health-topics/asthma/>

demonstrate how origami paper spacers could be used as a substitute for more costly medication administration devices<sup>48</sup>.



**Fig. 92**

DIY Spacers for Asthma Attacks  
2007

Origami-Spacer being used by an asthmatic child  
demonstrating its use in a clinical setting

<http://medgadget.com/archives..html>

The notion of taking steroid medicine can be intimidating for children and their parents, who fear long-term side-effects<sup>49</sup> such as osteoporosis (a condition commonly associated with athletes who misuse large doses of steroids). Most doctors will prescribe low doses of steroids that are less harmful to the body's natural growth in children. Because the steroids are directly inhaled to the lungs, there is a reduced chance of them getting into the blood-stream. Most doctors or specialists advise that children rinse their mouths with water after every dose to prevent any of the inhaled steroid

---

<sup>48</sup> Further information can be found at //medgadget.com. An extremely affordable device for better asthma care (better breathing with origami).

<sup>49</sup> Asthma UK (2007) *Asthma Mini Combined Low – Haynes Manual* [online] available from: <http://www.asthma.org.uk/document.rm?id=372> [Accessed 05 May 2007]



medicine being swallowed. Also, patient's who use inhalers regularly tend to experience a sore throat, caused by infection, or a noticeable change to taste and smell, due to the residue of medicine that has coated the tongue, throat or nasal channel. Figs. 93 and 94 show oral thrush caused by the excessive use of inhalers and steroid aerosol medication.



**Fig. 93**

Oral Thrush due to Corticosteroid Drugs for Asthma  
2006

Science Photo Library Harrow, London  
Inv. no. M130/332

**Fig. 94**

Oral Thrush due to the use of Becotide Inhaler  
2006

Science Photo Library, Harrow, London  
Inv. no. M130/270

The problem is caused by a build-up of corticosteroid which is commonly found in aerosol steroid medicine. The following test was conducted to reveal whether different nozzle shapes could be used as part of the design to help control and reduce the quantity of aerosol Beta-2 agonist and steroid medicine that might coat the tongue, palate and parts of the pharynx.

TRIAL TESTING VARIOUS NOZZLE SHAPES TO CONTROL THE FLOW OF AIRBORNE AND GLOBULAR AEROSOL MEDICINES.

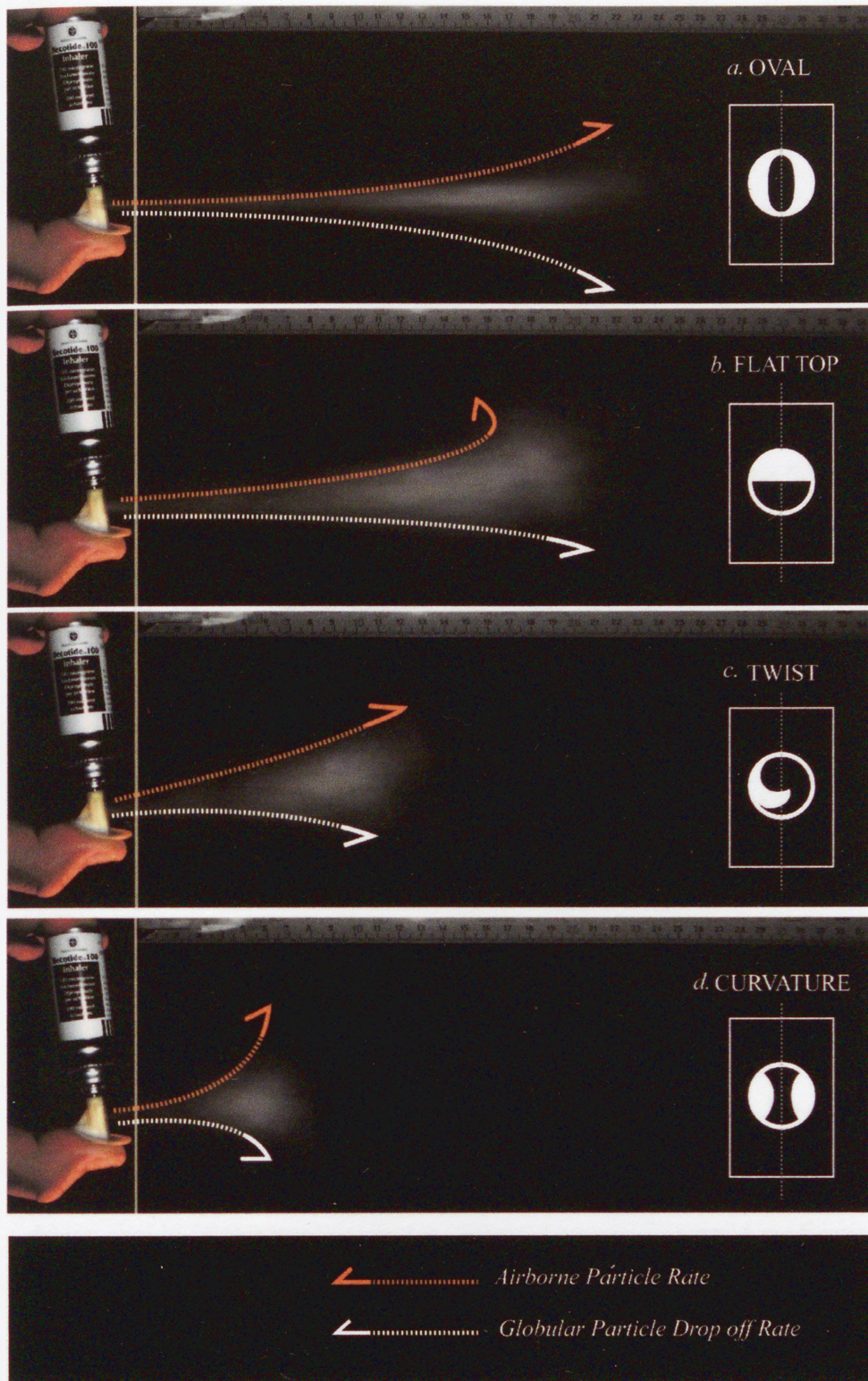

Images (a. through to d.) show the various nozzle types being tested for performance. This was achieved by taking a sequence of photographs taken over a single second with the purpose of capturing the aerosol medicine being propelled into the open air at high speed. A single frame was extracted from the sequence to show the optimum spread of medicine and the distance it travels before dissipating.

<<**Fig. 95** (Previous Page)

(a. through d.) Trial Testing Various Nozzles Shapes  
To Control the Flow of Airborne and Globular  
Aerosol Medicines,  
2007  
© Leon B M Williams

Centre for Jewellery Research,  
Royal College of Art, London

Tests with varying nozzle shapes have revealed that the aerosol medicine can be controlled as it escapes the canister under pressure. The flow of lighter airborne and larger globular medicine particles travels further in test *a.* as opposed to test *d.* where it (the flow) travels the least distance. The objective here was to test if different nozzles shape influenced the flow and amount of Beta-2 agonist and steroid medicine with the purpose of reducing the amount of medication coating the palate, tongue and oral cavities. Avoiding digestion, and discomfort to the lining of pharynx, epiglottis or larynx when used long-term. It also makes the breathing process easier for people that cannot draw enough air required to make best use of the medicine, providing valuable seconds for the patient to inhale the medicine without the inhaler blocking the mouth and restricting the flow of air.

The importance of the design of the nozzle is three-fold: firstly, the patient should be given more control over the use of the medicine; secondly, the design should inhibit larger globules of Beta-2 agonist or steroid medication coating the inner parts of the mouth; and thirdly, it should reduce the unpleasant taste that can build up on the tongue, throat and larynx. All of which can contribute to the reduced use of other more cumbersome inhaler accessories (such as the spacer device), making it easier to handle and more practical to manage.

For many patients, the procedures involved in operating an inhaler are straightforward and effortless. For some however, the act of using an inhaler can be difficult and strenuous. It is a common fact that as we age, the peripheral limbs, hands and fingers begin to lose their strength, which is not helped by the repetitive act of using an inhaler device. Also, patients suffering from arthritis tend to find this action of administering their medicine extremely painful, and embarrassing, because their hands are unable to grip and trigger the actuator: dexterity of the fingers is necessary. For the designer, this is an ergonomic problem which needs addressing. The medicine is designed to assist in the prolonging of life, and this includes treating patients as they become more sensitive to the mechanical and practical use of the device. Fig. 96 details the evolutionary developments that finally led to the first generation of slim-line inhalers being created to deliver aerosol medication from a slim-line inhaler alternative that could adorn the body like jewellery.

The main objectives of the jewellery inhaler are:

- To decrease the number of patient asthma attacks
- To bring improvement to the patients' quality of life
- To reduce the need for rescue medication (short-acting bronchodilators<sup>50</sup>)
- To improve asthma control
- To apply additional grip to inhaler device
- To function as a contemporary piece of jewellery/adornment

---

<sup>50</sup> Asthma Cure (2007) *Bronchodilator Medicines – Symptom Reliving* [online]  
"http://www.asthmacure.com" www.asthmacure.com [Accessed 01 January 2007]

THE NEW SELF-ASSEMBLE SLIM-LINE-INHALER  
*Design Evolution (At a Glance)*



Images (a. through g.) show the key design developments (at a glance) that led to the making of the new slim-line inhaler. Accessibility, performance, durability, and cost were the key considerations that guided the development of the new device. It complied with many of the health and safety requirements, and even had a new (built in) safety mechanism to prevent the discharge of aerosol medication when transported in a bag or luggage. On a practical level, the new inhaler was developed to be more discreet and comfortable when carried close to the body. When carried in the pocket or on a chain, the patient is better equipped to deal with the effects of asthma as they occur without the need to search the home or workplace for their vital medication, which can be stressful and dangerous in emergencies. Prototypes (e, f and g.) were designed to disassemble for the replacement and cleaning of new or old mechanical parts. The patient is given the confidence to change parts of the inhaler to suit their aesthetic needs.

<< **Fig. 96** (Previous Page)

First Generation Slim-line Inhaler Mechanism

Resin rapid prototyped model

2007

© Leon B M Williams

Centre for Jewellery Research,

Royal College of Art, London

Fig. 97 illustrates the first generation of slim-line inhalers in trial testing. Ten participants with asthma were asked to assemble the inhaler device without any prior knowledge of the mechanical design.

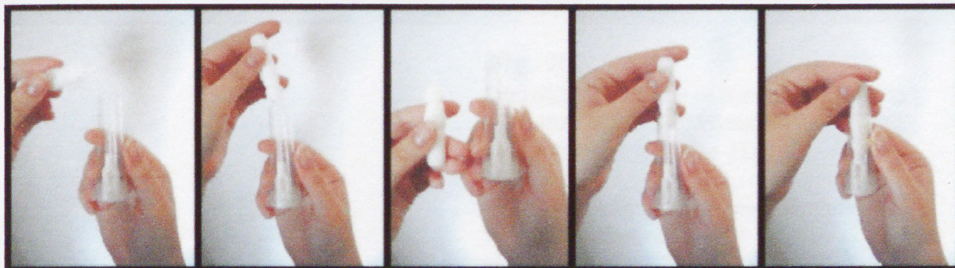

**Fig. 97**

© First Generation Slim-line Inhaler being Trial Tested by a Volunteer

Resin rapid prototyped model

The following snapshots show how the volunteer assembled and used the mechanism with success in no more than 15 seconds without assistance or prior knowledge of using the device.

2007

Leon B M Williams

Centre for Jewellery Research,

Royal College of Art, London

All participants managed to assemble the device within 15-30 seconds. They were able to easily identify and assemble each component of the inhaler. Later a second generation slim-line inhaler was developed, with a protective cap design (shown in blue in Fig. 98).

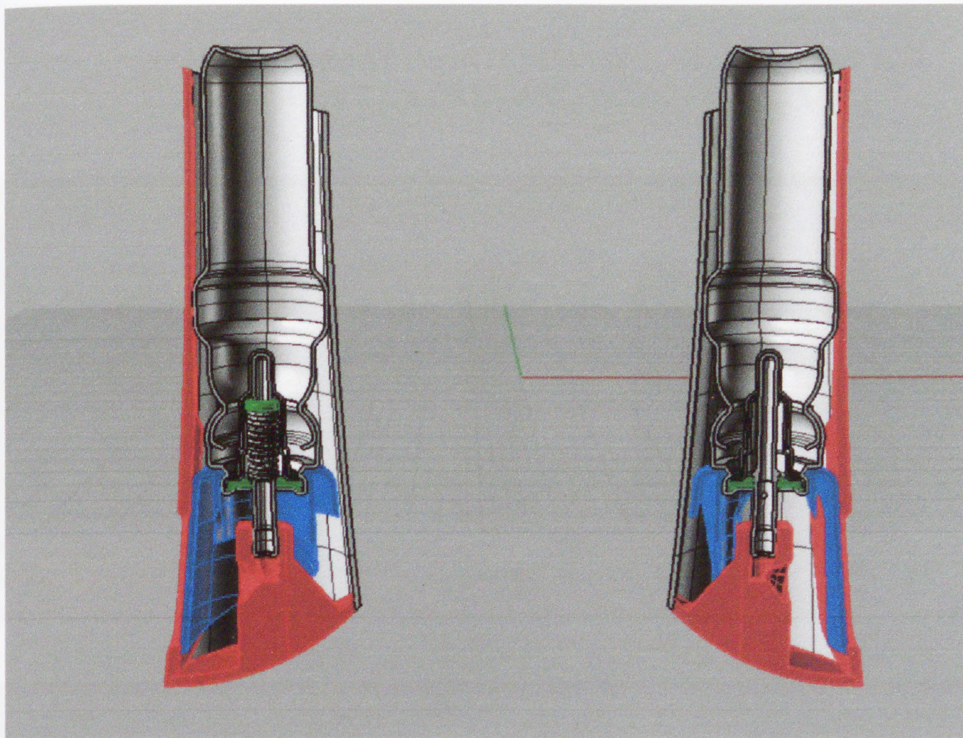

**Fig. 98**

Intersection Preview of Second Generation  
Slim-line Inhaler Mechanism

Virtual Design in Rhino 3D

2008

Developed to hold, carry and administer  
aerosol medications.

© Leon B M Williams

Centre for Jewellery Research,  
Royal College of Art, London

Another design consideration was to implement interchangeable cases for the slim-line inhaler, to make it easier for the patient to personalise their case to suit the different occasions on which it is worn.

STANDARD ARRAY OF INTERCHANGEABLE COVERS FOR  
USE BY CHILDREN AND YOUNG ADULTS

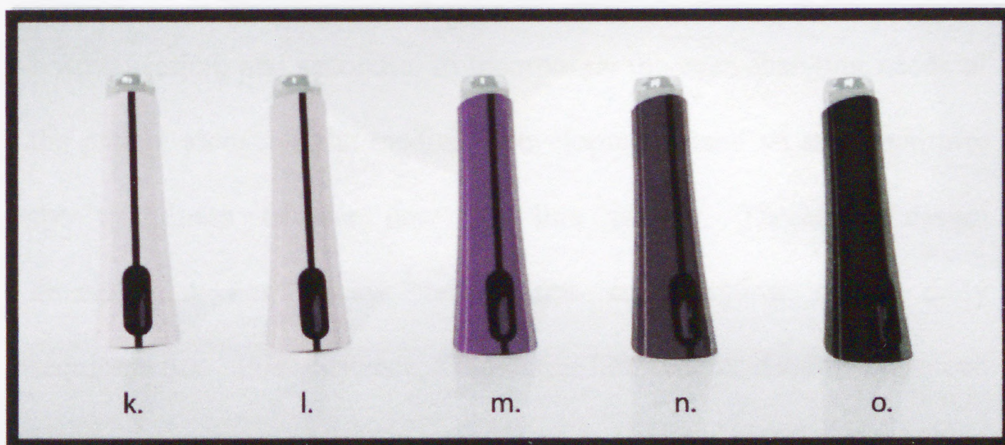
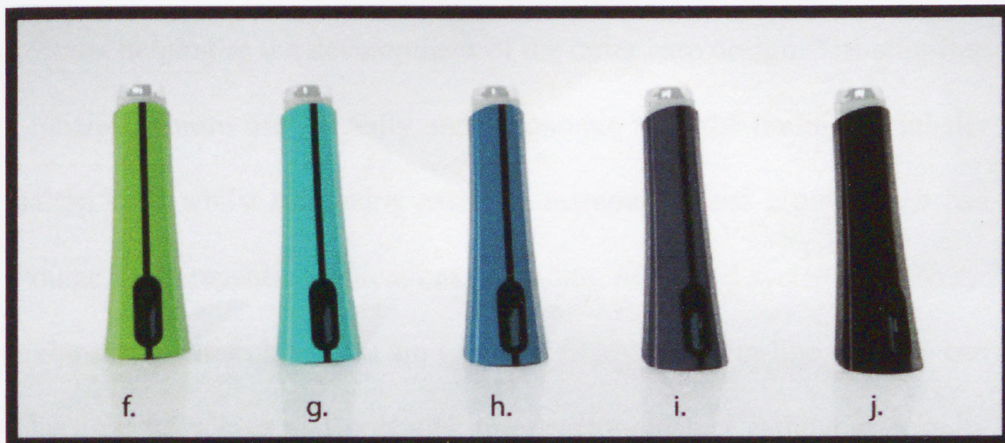
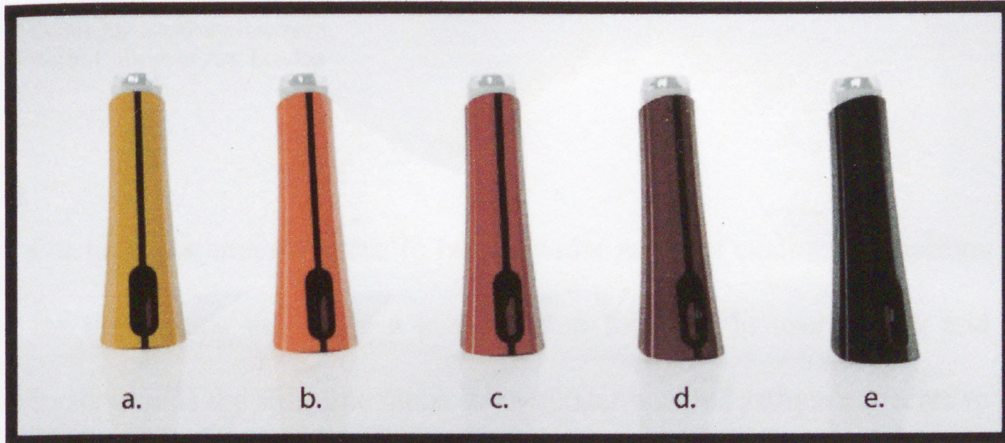

Interchangeable covers (a. through o. are design simulations) developed for use by children and young adults. The following variations demonstrate a selection of colour combinations that could be made available. The interchangeable feature makes it easier to personalise the inhaler. The wearer is also given the choice to select, wear and personalise each case – giving an element of control that might not be available to the wearer when using other inhaler products.



<< **Fig. 99 (Previous Page)**

Standard Array of Interchangeable Covers  
for use by Children and Young Adults

2008

© Leon B M Williams

Centre for Jewellery Research,  
Royal College of Art, London

For many asthma sufferers, to have a wider range of customized options for the asthma inhaler is a positive step forward. In user testing and focus groups the slim-line meter dose inhaler enabled asthma sufferers to test a product type that can be used in a similar way to existing products, whilst helping in the development of the outer case design. The slim-line inhaler is more user-friendly and ergonomic than the traditional inhaler alternative whilst also being easier to manipulate, and provides a broad range of therapeutic applications, including improved systemic delivery. The therapeutic objectives are twofold: firstly, the slim-line inhalers can be used to relieve and postpone the development of asthma attacks by treating its symptoms directly with the intent of reducing the need for hospitalisation; and secondly, to incorporate the ever-changing needs of the patient alongside the medicine development itself so as to optimise the usefulness of the new slim-line inhaler. Therefore, design development has always taken into consideration users' daily requirements. For instance, the slim-line meter-dose-inhaler can overcome some social stigmas associated with the traditional inhalers. Every patient using an inhaler has different requirements and needs. The jewellery based asthma inhaler is ergonomically designed to fit the contours of the hand, whilst making it easier to carry.

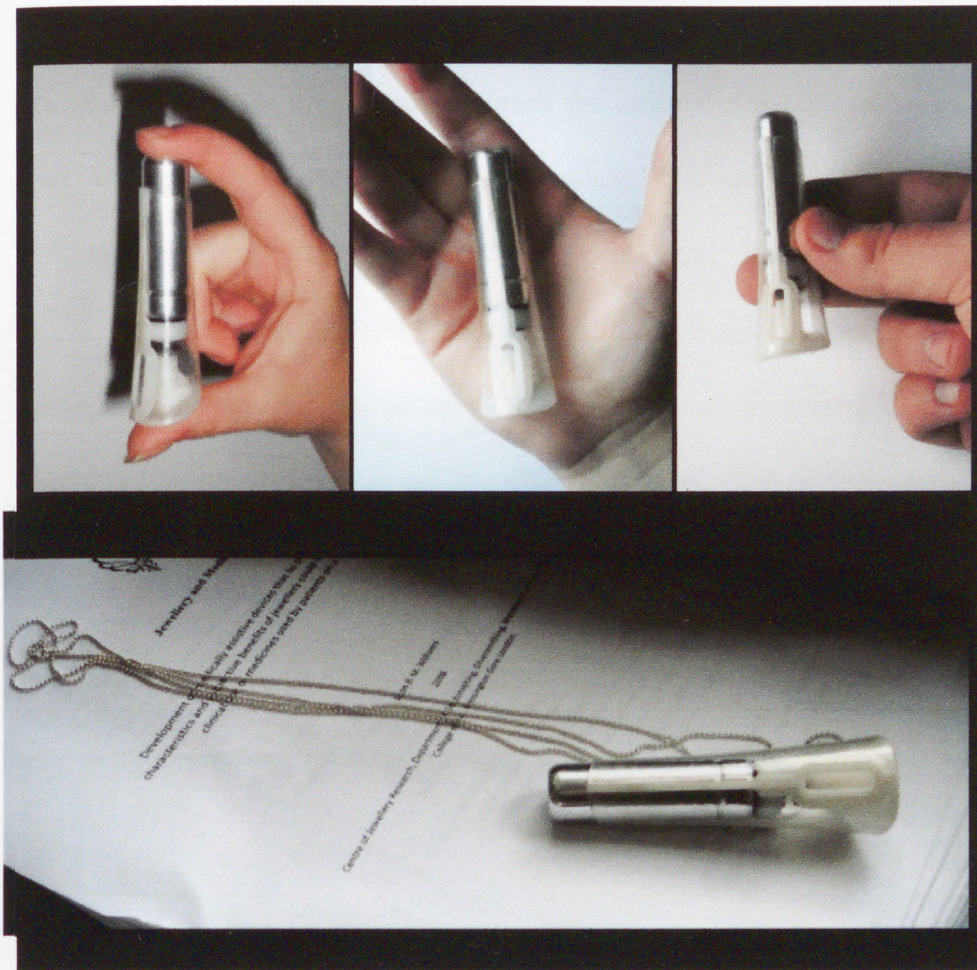

**Fig. 100**

Set of Images Showing the New Slim-line Inhaler Model.

Silver canister with clear resin case

2008

© Leon B M Williams

Centre for Jewellery Research,  
Royal College of Art, London

Use of the slim-line inhaler developed within this project could improve the efficiency and speed required when taking the medication. It could also help the patient to suppress asthma related side-effects that contribute to bronchial hyper-responsiveness and would otherwise be a cause for panic. The slim-line inhaler holds less medicine doses than

usual existing devices, meaning that the formulations, enhancement, or compliance of new drugs can be tested for optimal delivery in routine trial testing. Each substance can be used sparingly with optimal efficiency, safety and dosing convenience in mind. Thumb grips and chain attachments were later incorporated into the final prototype; the design could be easily taken apart for cleaning and accessing hard to reach components that would be difficult to sterilise in alternative inhalers.

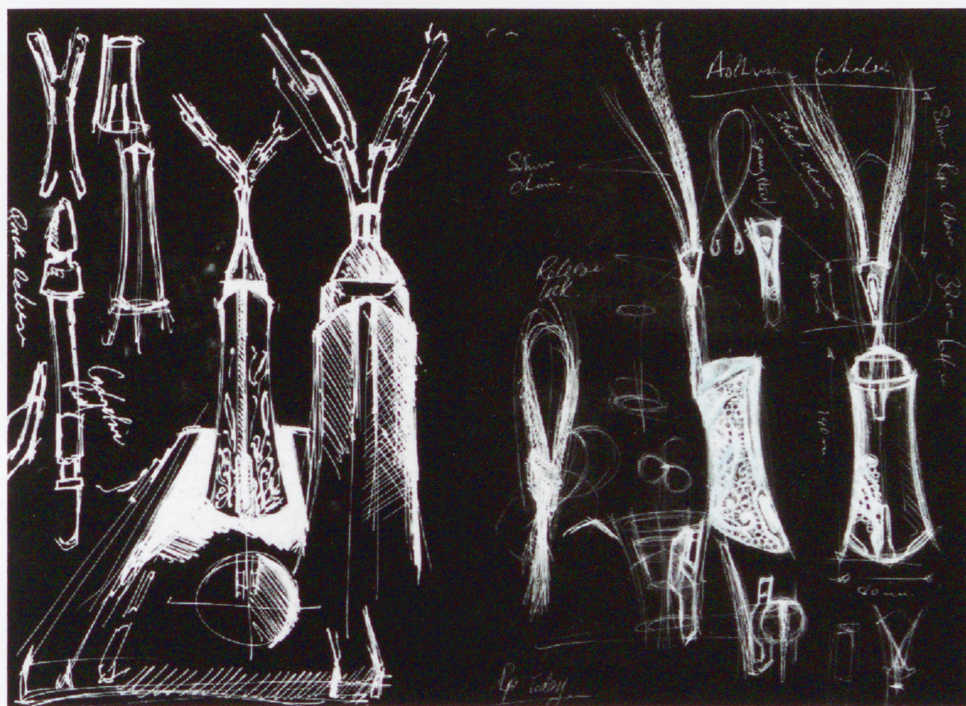

**Fig. 101**

Design Sketch of the Thumb Grip and Chain Attachment.

2009

© Leon B M Williams

Centre for Jewellery Research,  
Royal College of Art, London

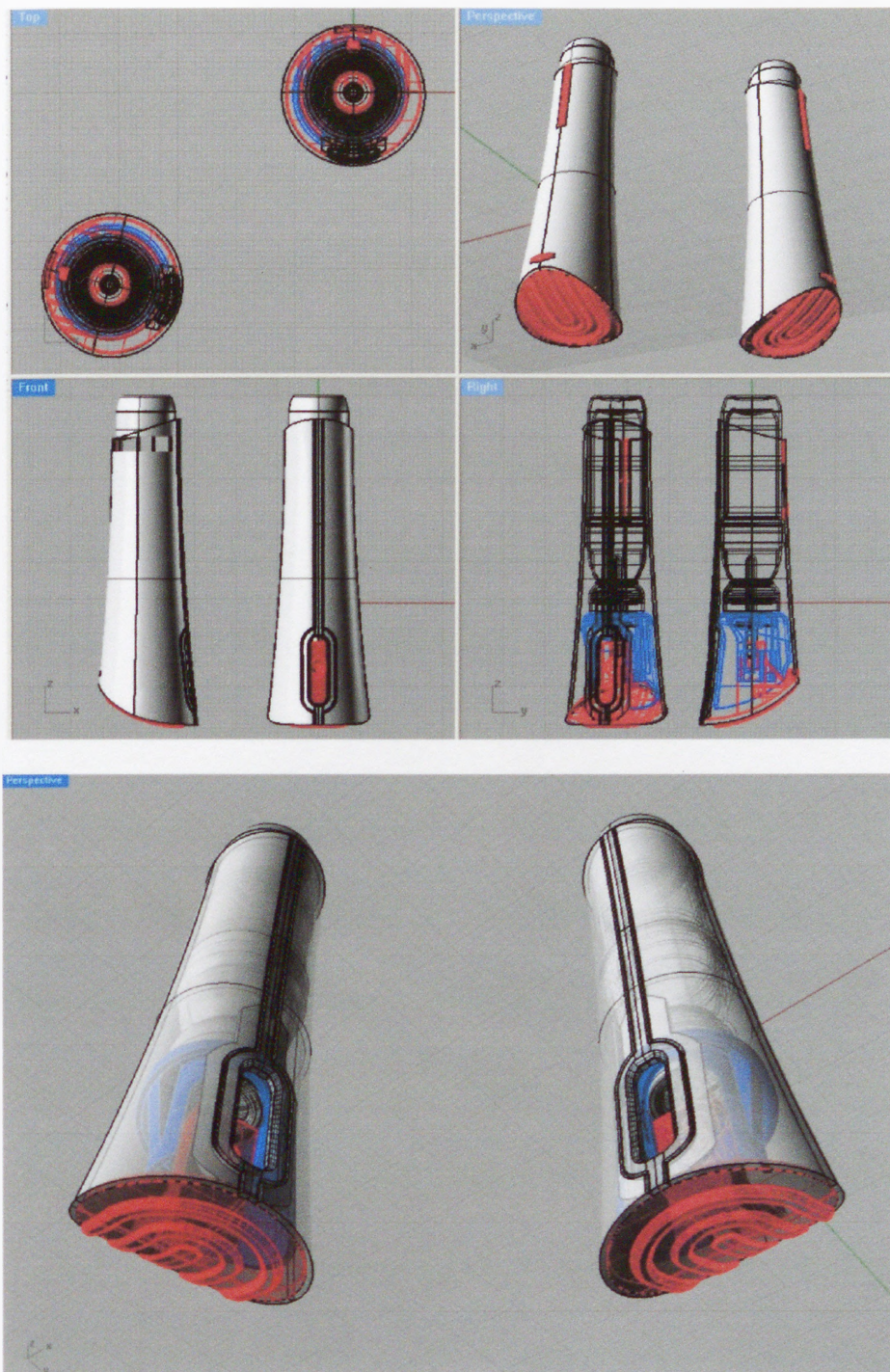

**Fig. 102**

3-Dimensional Drawings of the Slim-line  
Inhaler with Rubber Thumb Grip Design and  
Chain Loop

2009

© Leon B M Williams

Centre for Jewellery Research,  
Royal College of Art, London



**Fig. 103**  
Gold Slim-line Inhaler with Silver Grip and  
Engraved Canister  
2009  
© Leon B M Williams

Centre for Jewellery Research,  
Royal College of Art, London

There are many aerosol manufacturers producing different compound medications. Table 4 shows some of the main types of medicines that the new slim-line inhaler would support.

**TABLE 4: COMPATIBLE MEDICINES FOR USE WITH THE NEW SLIM-LINE INHALER**

Types	Chemical Names	Brand Manufactures
Short-acting Beta-2 agonists	Bambuterol	Bambec
	Salbutamol	Easyhaler, Pulvinal, Cyclohaler, Asmasal Clickhaler, Salamol Easi-Breathe, Ventodiscs, Ventolin, Volmax
	Terbutaline	Bricanyl Turbohaler
Long-acting Beta-2 agonists	Formoterol	Foradil, Oxis
Inhaled steroids	Beclometasone	Beclazone, Filair, Pulvinal, Becotide, AeroBec, Asmabec Clickhaler, Beclazone Easi-Breathe, Becodisks, Qvar, Becloforte
	Budesonide	Pulmicort, Symbicort - a combination of budesonide and formoterol
	Ciclesonide	Alvesco
	Fluticasone	Flixotide, Seretide - a combination of fluticasone and salmeterol
	mometasone furoate	Asmanex

KEEP OUT OF THE REACH OF CHILDREN

Avoid storage of indirect sunlight or heat. Protect from frost store below 25 °C  
Pressurised aerosol canister - do not puncture, break or burn, even when empty.

**125 Doses**

**Salbutamol** BN 978651  
Store below 25 °C EXP 05/12

100 MCG/  
INHALATION

Important: Read instruction Leaflet before use

Dosage: For inhalation as directed by the doctor.

Generic [UK] Limited, Royal College of Art, SW7 2EU



KEEP OUT OF THE REACH OF CHILDREN

Avoid storage of indirect sunlight or heat. Protect from frost store below 30 °C  
Pressurised aerosol canister - do not puncture, break or burn, even when empty.

**125 Doses**

**Beclazone** BN 978651  
Store below 30 °C EXP 05/12

100 MCG/  
INHALATION

Important: Read instruction Leaflet before use

Dosage: For inhalation as directed by the doctor.

Generic [UK] Limited, Royal College of Art, SW7 2EU



**Fig. 104**  
New Label Designs, for use with the Slim-line Inhaler - Salbutamol & Beclazone medicines  
2009  
© Leon B M Williams

Centre for Jewellery Research,  
Royal College of Art, London

For the purpose of distinguishing one type of medication from another, it was necessary to design a new translucent label. Fig. 104 shows two possible examples, for salbutamol and beclazone. It was important that the slim-line inhaler could accommodate different medications, but at the same time they should be easily identified in times of need. The new label design details generic chemical names, cartridge dose amounts, and expiration date, clearly labelling the contents and use.

## SUMMARY

*- Overview of the New Slim-Line Inhaler -*

The key to the slim-line inhaler designed as jewellery is to improve current design, make the device easier to use, remove or reduce any social stigma, either felt by the patient, or from society in general. The slim-line asthma inhaler has achieved many of these requirements. Its design has been trialled by focus groups, and approximately 87% of users found the overall design, and use of the inhaler an improvement on existing designs, with 80% confirming that they would like the new inhaler design to be a commercial alternative to existing options.

The slim-line inhalers would be more expensive than current meter dose inhalers, but they have been designed for multiple uses (especially silver / gold options) making them, overall, more cost effective in the long-term. There are also less costly options made from plastic, which could, dependant on manufacturing supply requirements, become more cost effective, in line with current products. The slim-line inhalers have also been designed with the objective of not being concealed, but being worn on the body, allowing the medicine to be a more integrated part of the patient's life. Fro this reason the shell had been developed to be more attractive and acceptable as jewellery, not just a medical product. This integration of function and aesthetics is key, enabling the new inhaler to be accessible to the patient at all times, for example, not concealed in a bag and difficult to find.



The jewellery asthma inhalers, would be a new way of controlling asthma, and therefore would require initial instructions and perhaps demonstration by a medical practitioner. This however is no different to the current situation in which new inhaler users are instructed on how to deal with usage of a current asthma device for the first time. This issue could therefore be easily overcome.

The delivery system within the new inhaler also delivers medicine to the airways and lungs without the use of a spacer or valve, making it more convenient for application at home or in a work environment. In the longer term, it could possibly become a replacement for more cumbersome nebulisers that require extensive cleaning and can be tricky to maintain. The overriding aim within this particular project is to improve quality of life and help improve individual patients personal control of asthma. The slim-line meter dose inhaler proved successful as a desirable object and as a medical aid, delivering both beta-2 agonists and corticosteroid drugs for patients at home or in a clinical setting.



**Fig. 105**

Design Proposal for New Slim-line Inhaler  
Black plastic with gold detailing and  
integrated rotating mouth guard/ safety cap  
2009

© Leon B M Williams

Centre for Jewellery Research,  
Royal College of Art, London

Most patients today are aware of the dangers of continually using aerosols or corticosteroids and demand alternative forms of preventative medicines or herbal remedies to help reduce the use of corticosteroids so that asthma does not interfere with their daily life. In the case where tablet additions are needed, the pill-pomander could also be used by the patient to carry add-on tablet medication such as Leukotriene - an antagonist tablet alternative to the aerosol long-acting beta-2 agonist medicines - or Theophylline - a slow acting medicine that is used by asthmatic patients over 24 hours to relax and open up the walls surrounding the throat.



**Fig. 72** (from chapter three)  
Third Generation Interchangeable Pill-  
Pomander  
Gold with black resin panels  
Design simulation  
2008  
© Leon B M Williams

Centre for Jewellery Research,  
Royal College of Art, London

The overall benefits of the compact slim-line jewellery inhaler are: more effective treatment with fewer side-effects, as the medicine is made more freely available to the wearer in times of need; overall, the device is more compact, lightweight and portable compared to the traditional L-shaped meter dose inhalers; it is easy to handle when carried in the pocket or worn on a chain; the accessibility of the design makes it inclusive for use by all age groups including young children from the age of 7 to the elderly, even with arthritis in their hands or wrists. The cost of the inhaler is relative to the materials used in its manufacture – meaning that the patient is given the choice of choosing between a plastic or more expensive platinum version. Both will function in compliance with government standards and accommodate the lifestyle of patients with different needs and will reduce social fears like Iatrophobia by making the condition more widely accepted within the family or nearby community.

# CHAPTER 5

<b>PROJECT DIABETES</b> <i>Design Development</i>	187
<b>THE BEGINNINGS OF DIABETES AWARENESS</b> <i>Historical Development of Insulin Delivery Systems</i>	188
<b>PATIENT SELF-CARE</b> <i>Using Insulin Delivery Systems</i>	194
<b>UNDERSTANDING DIABETES</b> <i>As we know it today</i>	195
<b>DEVELOPING A NEW HOME GLUCOSE MEASUREMENT SYSTEM (HGMS)</b> <i>Analysis Methods</i>	196
<b>A NEW INSULIN DELIVERY SYSTEM (IDS)</b> <i>Syringes and Pens</i>	215
<b>A NEW MEASUREMENT GAUGE</b> <i>Accurate Dose Measurements</i>	221
<b>A NEW SAFETY CAP DESIGN</b> <i>Needle Related Issues</i>	224
<b>THE DEVELOPMENT OF THE DISPOSABLE NEEDLE SAFETY GUARD</b> <i>Protecting the Body</i>	225
<b>PREVENTING NEEDLE SHIFT</b> <i>-Developing a Tilt-Sensor to Monitor and Control Needle-Movements when Administering Insulin</i>	230
<b>DEVELOPING A PERSONALISED MANAGEMENT TOOL FOR THE BABY-BLUE SOFTWARE</b> <i>Personalised Management Software</i>	236
<b>SUMMARY</b> <i>Overview of the HGMS and IDS</i>	238
<b>FUTURE DEVELOPMENT</b>	241

## PROJECT DIABETES

*-Design Development-*

Project Diabetes focused on the development of a new home glucose measurement system (HGMS) and a new insulin delivery system (IDS). This included a new lancet mechanism, glucose meter, and insulin injector device. This part of the research was designed to demonstrate the usefulness of medical-jewellery, whilst inventing new pharmaceutical products for diabetic type I patients. Not all outcomes developed here are intended to provide a definite solution for diabetic patients. They do however, offer an alternative way of thinking and creative practise aimed specifically at researchers or craftsmen who are working towards the development of future pharmaceutical products.

Here I addressed some of the most significant milestones in history that have influenced the development of diabetes awareness, treatments, and self-care devices. This was complemented by discussion of how such advancements helped shape the way patients use, carry, and administer their insulin medication today. I then focused on the development of new compact technologies that could be used to support, carry and administer insulin. A problem / solution methodology was practised here. Finally, I concentrated on some of the most controversial fears associated with carrying and using insulin by developing new practical ways to safeguard the patient from needle-related fears and on complications arising through jewellery design. By considering ergonomic use and aesthetic pleasure when wearing an insulin device as jewellery for daily use and in cases of emergency.

## THE BEGINNINGS OF DIABETES AWARENESS

*-Historical Developments of Insulin Delivery Systems-*

The earliest documented evidence of a diabetes related illness can be found amongst the 877 passages of the Ebers papyrus (dated 552 BC)<sup>51</sup>. In reference to 'excessive urination' - a principal symptom of diabetes which is known today as polyuria - is prescribed "...*a medicine to drive away the passing of too much urine*". This manuscript appears to be the earliest evidence of polyuria, and may even be the first diagnosis of diabetes<sup>52</sup>. The next significant milestone was recorded in Hindu medicine (about 500 BC.), when diabetes became recognized during what is known as the Brahman period. Expert water tasters were given the duty of drinking the urine of those suspected of having diabetes to evaluate its sweetness, which is where the Latin word 'mellitus' derives, meaning 'honey sweet', and is even today referred to as a type of diabetes prognosis. The word diabetes was defined in the English dictionary in 1425 for the first time - referred to as 'diabete'. Soon after the word was in popular use.

Over 200 years later, the English diagnostician Thomas Willis, in the 1674 works *Pharmaceutice rationalis*, practised and expanded on the theories described within Hindu medicine. He commented on the clarity and sweetness of diabetic urine and how this taste testing caused "...*good*

---

<sup>51</sup> Papyrus NS. (1964) *The History of Diabetes Mellitus* (second edition). Stuttgart: Georg Thieme Verlag; (1989).

<sup>52</sup> Descriptive writing by Apollonius of Memphis about 230 B.C references patients "without retention" of urine: His theory explores the condition and likens it to a form of 'dropsy' - An old descriptive term meaning swelling of soft tissue due to the accumulation of excess water.

*fellowship and guzzling down of...wine*".<sup>53</sup> At this point in time, diagnosticians could only advise how to control the intake of food, since prior to the invention of the first hypodermic syringe (fine enough to pierce the skin) in 1853 it was technically difficult to administer drugs. The development of such a syringe was received by the medical industry as a pioneering feat of achievement and technology.

The hypodermic needle was developed independently (around the same time) by Scottish physician Alexander Wood (1817-1884) and French surgeon Charles Gabriel Pravaz (1791-1853). The needle had a pointed hollow section made from steel with an appended hard rubber slide. It was first used to inject morphine as a painkiller and then later used for other medicines, like insulin. Artefacts like the 'hypodermic needle and silver-gilt cases' Fig. 106 show the craftsmanship of the needle, syringe, and carry case, possibly made for Victorian doctors or wealthy patients.

---

<sup>53</sup> Willis T. (1679) *Pharmaceutice Rationalis: Or and Exercitation of The Operations of Medicines in Humane Bodies*, Oxford: Dring, Harper and Leigh Publishing, pp. 79-88. Referring to the "*Pissing of Evil*." In his chapter on opiates and their use and the patients "*wonderfully sweet*" urine



**Fig. 106**  
Hypodermic Syringe  
with a Spare Needle and Metal case  
Late 19th century  
England  
Silver-gilt with floral engraving

Science Museum Picture Library, London  
Inv. no. 10284540

Victorian diabetic patients still required to visit their local doctors to undergo urine tests, which were time consuming and expensive. It was not until 1911 when doctor S.R. Benedict refined a process of accurately measuring sugar levels in urine, naming it the 'Benedict's Solution'. For the first time patients were able to test the urine in a clinical setting. Only a few years later specialist, Frederick Madison Allen published in 1913 the "*Studies Concerning Glycosuria and Diabetes*", a pioneering book on the subject of diabetes therapy. From this point, the race to find a 'cure' for diabetes became ever more competitive. In 1920-1921, Dr. Frederick Banting with assistant, Charles Best, trial tested different medicines on de-pancreatized dogs, leading to the 'discovery' of insulin in 1921. However, this did not happen until 1922 through James Collip from the University of



Toronto. He developed a more sophisticated purifying process for insulin, leading to diabetic patient Leonard Thompson, aged 14, being the first recorded human to undergo insulin treatment with successful results.

In 1924-5 Dr Benedict<sup>54</sup> released the first home testing kits to measure the quantity of sugar in the urine. These test kits were made available to the general public for the first time. This made the experience less intrusive, giving his patients an element of responsibility and control that was previously not made available.

The next significant development was made by the Becton, Dickinson and Company in 1924, who manufactured their first syringe specifically for injecting insulin. The company became acknowledged as specialist makers of syringes, and for developing and improving their products in response to the concerns and difficulties of insulin dependent patients, thus contributing to the early beginnings of the insulin-injection therapy. Many variations of the all-glass syringe were made which included finger and thumb grip rests which made it possible to inject insulin with one hand. Alkali-free hard glass (Pyrex) was used to resist erosion caused by repetitively sterilizing the same syringe. In 1925, the ED Yale Luer-Lock syringe was designed by Fairleigh S. Dickinson, Sr. This incorporated improvements which had been made to the syringe instrument, including a 'removable cap' made of steel, allowing the needle to be both attached and detached from the glass syringe, thus avoiding accidents previously caused by the needle slipping off the

---

<sup>54</sup> A complex process that involved mixing (in a test tube) exactly 8 drops of urine with 6cc (1 tablespoon is equal to 5cc) of Doctor Benedict's chemical indicator solution. Then the mixture was placed in boiling water for approximately 5 minutes to encourage the mixture product to change in colour to reveal if sugar was present. Green - sugar content (light); yellow (moderate) levels of sugar; and orange/red (heavy) amount of sugar.

syringe tip while in use. The Luer-Lock connector is still applied in many medical devices of today.

More accurate readings were made possible for home use with the introduction of reagent strips for whole blood testing (regarded as an achievement in home assessment care-products for people with diabetes). In the late 1950's and early 1960's more accurate monitoring and treatments were used. Urinalysis reagent strips began to replace the test kits. However both products were still limited in accuracy due to inconstant concentration of glucose in urine samples passed out of the body at about the same time. Plus, the results only showed how the body had responded to glucose several hours prior to sampling. The glucose reactant comprised of an enzyme, such as glucose oxidase - a catalyst used in the oxidation process of glucose to gluconic acid and hydrogen peroxide. The other part is typically made up of an indicator or dye, such as o-tolidine, and a substance capable of catalyzing the dyes oxidation. Depending upon the concentration of glucose present in a sample, the dye product would visually produce a colour that for analysis would be measurable against an intensity chart that accompanied the kits. Also, the reagent strip required considerable care in the samples application. Patients were advised to blot excess blood that was applied to the pad on the strip whilst leaving it to oxidise over a precise period of time before analysis, thus improving the accuracy and consistency of the product. However, visually read strips have an error margin of around 20-25% (as opposed to glucose meters that have a 10-15% error margin).

By the 1960s major research was carried out in pursuit of a cure for diabetes: the purity of insulin was improved and devices were developed for home use. In 1964 blood glucose testing strips became readily available from the company Ames. Six years on, in 1970, the first blood glucose meter was commercially sold to the general public. During the 1980s the development of products to improve the life of diabetic patients was immense. The following inventions helped enhance people's lives:

- 1983 - The 'biosynthetic human insulin' invention
- 1986 - The compact insulin-pen and delivery system
- 1988 - The first safety-engineered syringe called the 'Safety-Lok'
- 1989 - The world's first prefilled insulin syringe: NovoLet®.

Further improvements came about in the 1990s when glucose meters were developed to make use of optical technology. Soon after these events, new developments and inventions seemed to decline as digital technology became more widely used in the field of medical research. Arguably, the introduction of digital technology in insulin delivery systems could be referred to as premature. Many of these technologies were still in their infancy and not sophisticated enough to be carried on the body. However, from the 1990s onwards, digital technologies became more technically sophisticated and mature in many ways.

## PATIENT SELF-CARE

- Using Insulin Delivery Systems -

Patient self-care is all important. The BABY-BLUE jewellery (developed in chapters 3 and 4) can only provide the wearer with the tools to practise and learn important skills about the way their body responds to daily stresses, medication or therapy routines. BABY-BLUE technologies *will not* relieve them of their health-care duties, but could be used to give support and confidence that the all important medication is working to maintain a healthy lifestyle.

As it stands, the diabetes research audit, 2005 indicates that diabetes affects more than 120 million people world-wide. This figure does not even take into account the five million people who are unaware of their condition. Type I diabetes, also known as 'juvenile diabetes' or 'insulin dependent diabetes' accounts for approximately 5% of the overall figure. It is considered to be the most severe type, as it can prove fatal if insulin is not administered on a daily basis, and has therefore been selected as a suitable project to best demonstrate the importance of putting BABY-BLUE technologies into practice.

## UNDERSTANDING DIABETES

*-As we know it today-*

Science today tells us that diabetes is a condition in which the body is unable to process the food that is eaten. This causes organs in the body, like the pancreas, to react unpredictably and produce insufficient amounts of the hormone 'insulin'. When a person eats or drinks something, part of it is broken down and converted into a sugar known as 'glucose'. It is this glucose substance that is needed by every cell in the body to grow and live. However diabetic patients do not have the ability to produce sufficient quantities of insulin to facilitate signalling to the blood to pick up and carry the glucose to its source (cells across the body). Without insulin, glucose is rejected and later passed out of the body unused. It is for this reason that a set of new devices (supported by BABY-BLUE jewellery) could be used to mediate complex eating and exercising rhythms, which can easily cause diabetic patients to take too much insulin, or alternately not enough at necessary times throughout the day.

## DEVELOPING A NEW HOME GLUCOSE MEASUREMENT SYSTEM (HGMS)





- Analysis Methods -

Diabetic patients at home measure and monitor their glucose levels through '*indirect*' methods. This means that there is no easy way to measure glucose concentrations directly from a sample of whole-blood or urine. This is due to inconsistencies that interfere with the results of the sample. Most commercial home glucose measurement systems (HGMS) overcome this problem by measuring the rate of reaction in a re-agent solution that chemically responds to glucose (as opposed to the glucose itself).

Before any practical development was undertaken, it was important to observe how diabetic patients monitor their blood-sugar levels. A diabetic patient was shadowed for a day and asked to demonstrate the advantages and difficulties of using a typical glucose meter and lancet device. Fig. 107 illustrates 24 steps taken by a middle aged diabetic man (with no physical disabilities) who has more than ten years experience of using HGMS.





24 PROCEDURAL STEPS TO PREPARE, MAKE READY, AND USE A HOME GLUCOSE MONITORING SYSTEM

0:00:12





1. open pouch      2. remove lancet      3. deactivative lancet mechanism      4. separate cap

0:00:32

5. remove used lance      6. dispose of lance      7. open box of new lances      8. select and check

0:01:07

9. detach protective cap      10. attach lancet to mechanis      11. set depth guage      12. remove test strips from pouch





0:01:14





13.find unused test strip      14. turn on glucose mete      15, calabrate glucose meter      16. insert unused test strip

0:01:52

17. set trigger on lancet device      18. lance the finger tip      19. draw blood sample      20. apply sample strip to test strip

0:03:05





21. wait for result      22. remove test strip and lance      23. dispose of test strip      24. dispose of used lance cap

<< **Fig. 107** (previous page)

24 Procedural Steps to Prepare, Make Ready,  
and use a Home Glucose Monitoring System  
Patient using the compact One-touch Ultra-2  
glucose meter and lancet

2008

© Leon B M Williams

Centre for Jewellery Research,  
Royal College of Art, London

Even with the experience gained through this period, the patient still has difficulties controlling and managing the HGMS, partly due to the number of components and complex processes involved (assembly, use and disposal). Also, the 24 steps need to be performed in a hygienic and private environment, which proved difficult due to the size and amount of equipment required. From this observation, it became clear that a new and more practical set of devices, worn on the body, could provide the user more freedom and control in testing their blood glucose in the environment of a home or public space.

The main reasons for developing the new HGMS were:

- To reduce the number of procedural steps to prepare, make ready, and use a lancet and glucose meter.
- To reduce the number of components.
- To make the entire process easier to manage.
- To develop a HGMS that can be realistically and comfortably performed in less than 3 minutes.
- To develop a HGMS that can be carried close to the body like jewellery and used without drawing negative attention in public spaces.



The most logical approach to develop a new working HGMS was to focus on the lancet device first and then on the more complex glucose-meter.

All diabetic patients need to perform self-test at least 4 times a day to monitor their blood-sugar-levels. The most common procedure is to extract a controlled sample (droplet of blood) from the finger, palm, or thigh using a lancet device.<sup>55</sup> If the test results of the blood levels are not within the desired range, insulin must be administered subcutaneously (under the skin) to stabilise the blood-sugar-levels. Fig. 108 shows three of the most popular self-care lancet devices used by diabetic patients today.

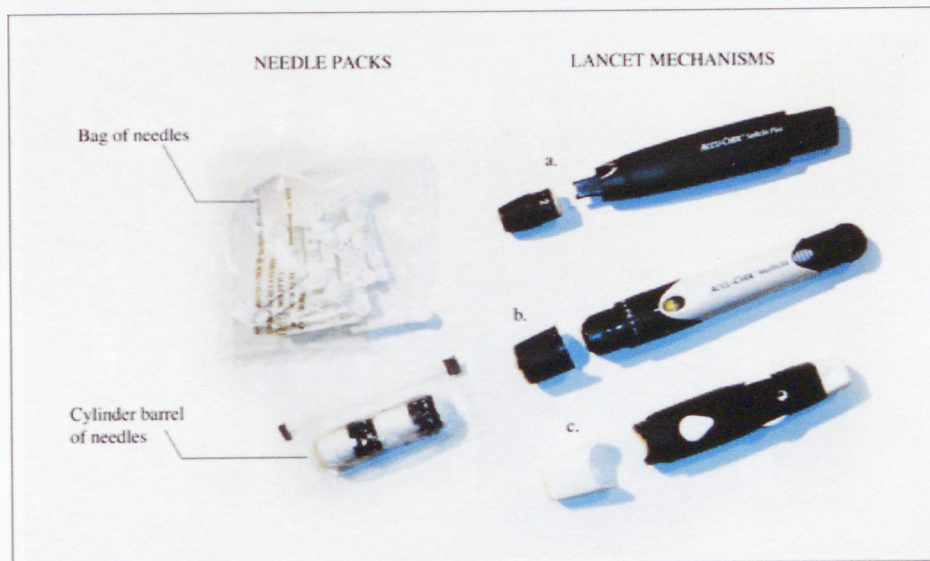

**Fig. 108**

(a through c.) Three of the Most Popular Spring-Loaded Lancet Mechanisms that are used by Diabetic Patients. 2006

© Photographs by Leon B M Williams

Centre for Jewellery Research,  
Royal College of Art, London

<sup>55</sup> A lancet device is a sharp pin-like instrument, typically made of steel. When attached to a spring-loaded mechanism, the lance is able to plunge into the subcutaneous layers (beneath the skin) at different depths to extract the sample of whole-blood.

Each of the three devices were trialled by eight participants for performance and ease of use over a 24-hour period. All participants were given a single lancet and asked to test their blood-glucose levels four times throughout the day. Most participants noted that the lancet devices were over-complicated and difficult to manage, due to the quantity of lances that needed to be carried on the person at any time. The lancets can be cumbersome, requiring the use of both hands to assemble and activate many parts of the device. Figs. 109 - 111 demonstrate a new lancet alternative, developed to be more discreet, easier to manage, and safer for the user.

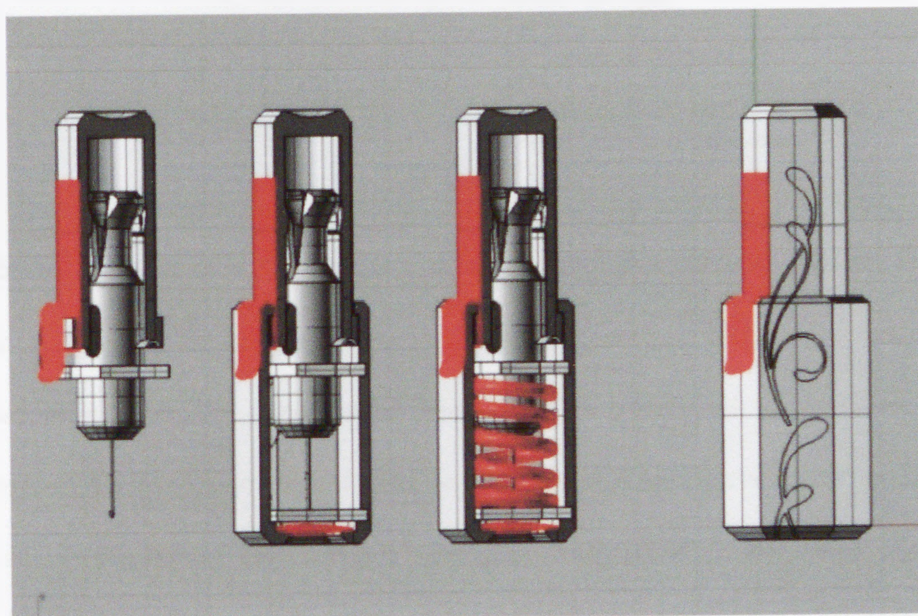

**Fig. 109**  
3-Dimensional Model - New Lancet  
Mechanism for Extracting a Droplet of  
Whole-blood for Testing.  
40mm in length.  
2007  
© Leon B M Williams

Centre for Jewellery Research,  
Royal College of Art, London

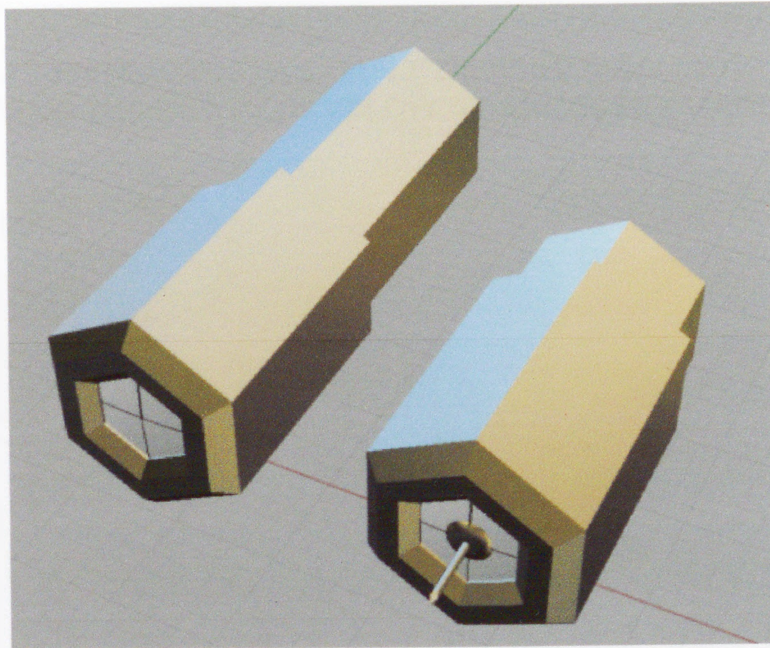

**Fig. 110**  
Perspective View of 3-Dimensional  
Model - New Lancet Mechanism for  
Extracting a Droplet of Whole-blood  
for Testing.  
40mm in length.  
2007  
© Leon B M Williams

Centre for Jewellery Research,  
Royal College of Art, London

The new lancet only requires a single action of pinching to activate the lance, reducing the chances of nervous flinching, and avoiding unnecessary discomfort typically experienced when using a traditional trigger loaded device. Another requirement was to develop a lancet device that could puncture the skin cleanly without leaving any scar tissue, whilst producing a 1-3 microlitres ( $\mu\text{l}$ ) sample of blood.

**Fig. 111 (Next Page) >>**  
Extracting a Sample of Whole-blood using  
the Newly Developed Lancet Mechanism  
2008  
© Leon B M Williams

Centre for Jewellery Research,  
Royal College of Art, London

## EXTRACTING A SAMPLE OF WHOLE-BLOOD USING THE NEWLY DEVELOPED LANCET MECHANISM

### LANCET SITES

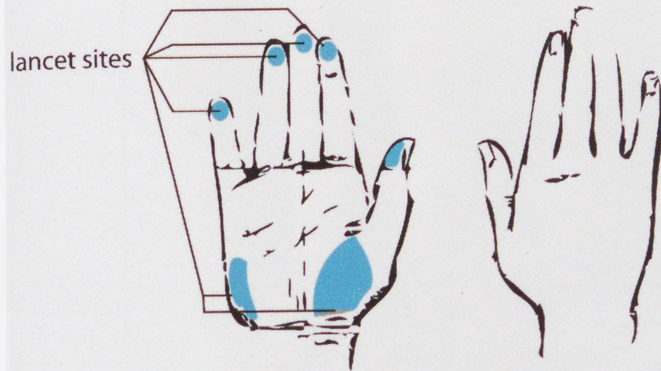

The lancet is designed for use with both hands if needed.

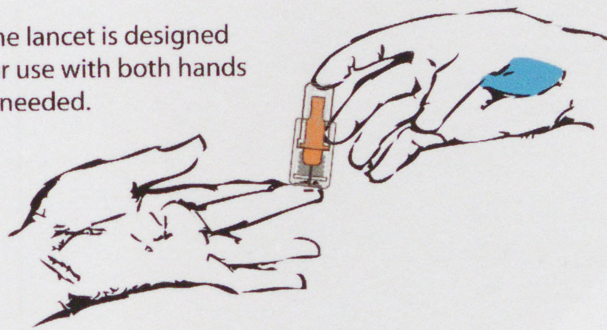

### LANCET PARTS

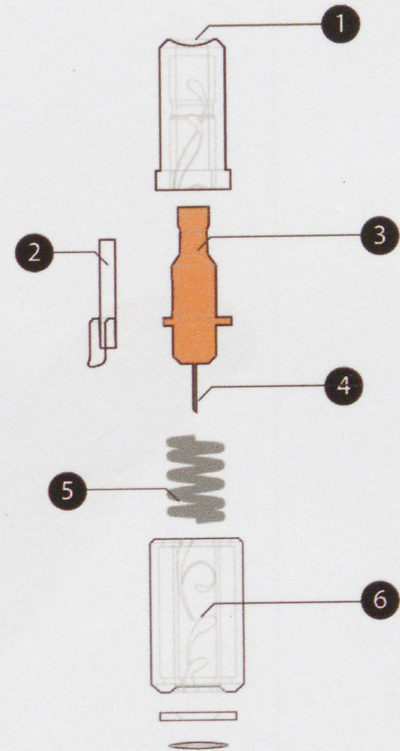

### PROCESS OF USE

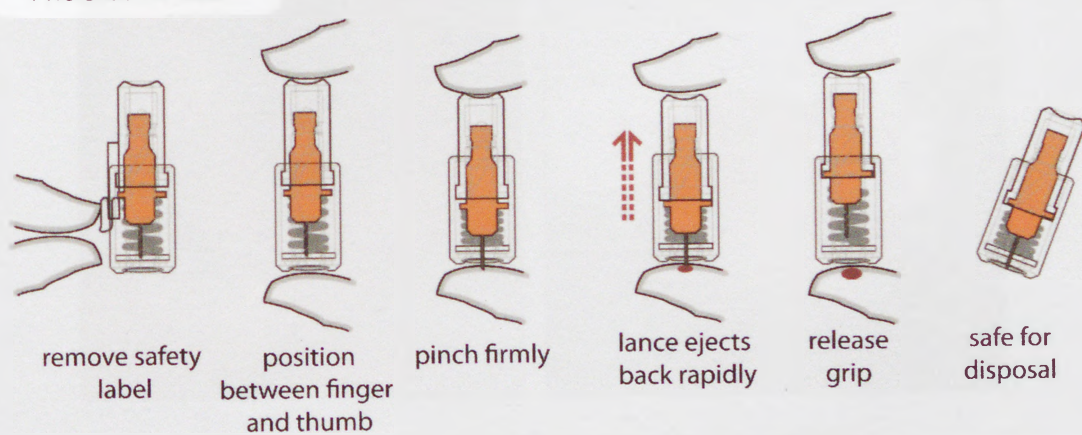

The following illustrations shows the mechanical parts of the new lancet mechanism. There are 6 main parts that make up the lancet. These being: 1. inner case 2. safety label 3. lancet mount 4. lance 5. spring, and 6. outer case. When the inner case and outer case is pinched together, the lancet mount is ejected back into the inner case, rendering the device inactive and tamper proof.



**Fig. 112 (top) Fig. 113 (Bottom Left) Fig. 114 (Bottom Right)**  
Trial Testing the New Lancet Mechanism  
Resin (type R11)  
Testing the newly developed lancets on two individuals with different skin  
thicknesses  
2008  
© Leon B M Williams

Centre for Jewellery Research,  
Royal College of Art, London

The prototype removes many of the problems associated with the daily use of a traditional lancet device; it does not require any assembly and is immediately ready for use. The lancet is also designed for single use only, with the lance retracting into the case automatically after use, therefore making it safer and easily disposable. Its package size is less than 40x15x15mm making it the smallest spring-loaded lancet device; this also has the benefits of being easy to carry and not drawing unnecessary attention when used in public spaces.

Traditional lancet alternatives can allow the gauge to be set too high, which could be too forceful and cause unnecessary pain and discomfort for the patient. The strongest feature of the new lancet is its retractable pin mechanism. This is beneficial as many people need to re-adjust the gauge depth on their lancet mechanism, factoring in skin thickness, depth, and sensitivity. The new lancet is able to overcome this problem by mechanically retracting the steel lance once it has broken the surface of the skin. It can be used on sensitive parts of the body or on tough skin, further optimising its use as a portable blood-extraction mechanism that is discreet and easy to manage.

The next stage was to develop a working glucose-meter that complemented the new lancet mechanism.

There were four main considerations that guided the development of the improved glucose-meter. These were:

- To reduce contamination of the sample (whole-blood or urine) when in transition between the lancet and the glucose-meter.
- To implement a practical way of reducing the mistakes caused through human error.
- To devise a practical way of testing the sample by converting the analogue reading to a digital output that can be easily understood by the patient.
- To best use and store the results for medical analysis.

Typically home glucose-meters are designed for performance and not aesthetics. The Accu-check glucose-meter and lancet device are cumbersome, indiscreet and mechanically heavy, expensive to manufacture and easy to break.

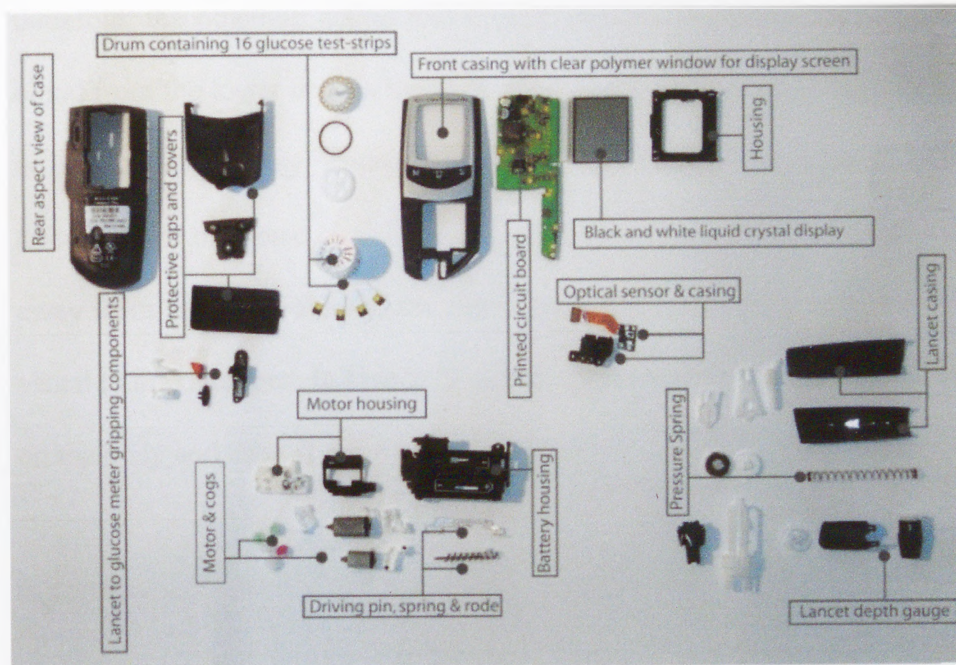

**Fig. 115**

Mechanical Parts of the Accu-check Glucose-meter and Lancet.

A popular glucose meter and lancet mechanism.

2007

© Photography by Leon B M Williams

Centre for Jewellery Research,  
Royal College of Art, London

One concern when using a typical glucose meter and lancet was the contamination of the blood sample. Even the smallest traces of glucose like, fruits, juices, and sugary drinks transferred via the patients' hands onto the sample or test strip can interfere dramatically with the readings and cause the patient to administer incorrect amounts of insulin.

Fig. 116 demonstrates a new circular test-strip. It fits on one end of the lancet and is designed for single use. When the lance breaks the surface of the skin the patient is only required to hold the lancet still for a few seconds to allow the blood droplet to transfer onto the circuit through capillary action whilst the patient pinches down. The advantages of this design are



threefold: the pinching action that triggers the lancet is also used to draw blood from the lower dermis layers, whilst the lanced site and blood sample is protected from any foreign contaminants; the circuit can draw blood directly from the lance site without the need for the user to pull the device away from the body; finally, the blood sample is at no time made directly visual to the other people in near proximity, making it practical to be carried on the body and used at any time in any location.

**Fig. 116 (Next Page) >>**

A New Circular Whole-blood Test Strip for  
use With the Newly Developed Lancet  
Mechanism and Glucose-Meter  
2008

© Leon B M Williams

Centre for Jewellery Research,  
Royal College of Art, London

A NEW CIRCULAR WHOLE-BLOOD TEST STRIP FOR USE WITH THE NEWLY DEVELOPED LANCET MECHANISM AND GLUCOSE-METER

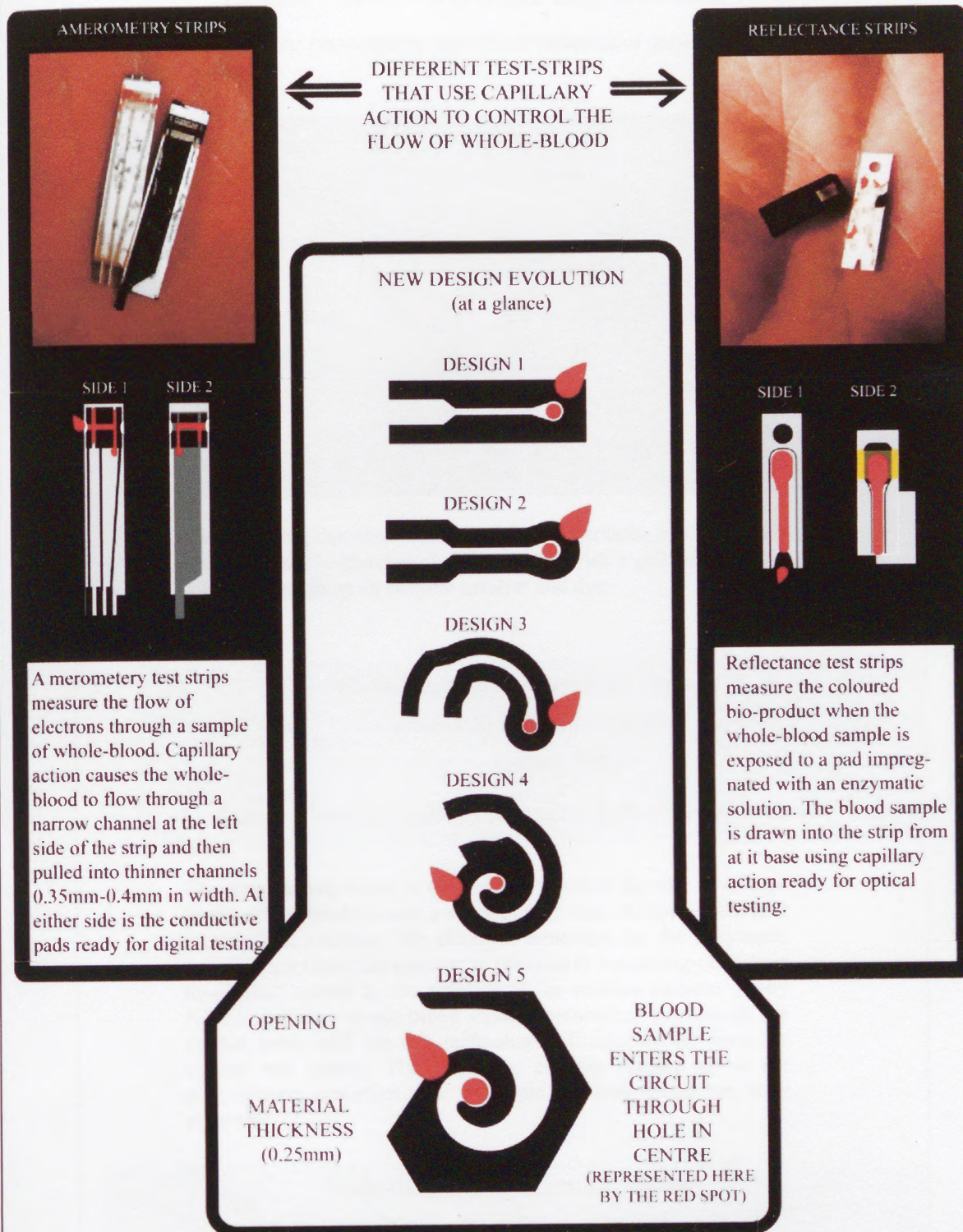

A merometry test strips measure the flow of electrons through a sample of whole-blood. Capillary action causes the whole-blood to flow through a narrow channel at the left side of the strip and then pulled into thinner channels 0.35mm-0.4mm in width. At either side is the conductive pads ready for digital testing

Reflectance test strips measure the coloured bio-product when the whole-blood sample is exposed to a pad impregnated with an enzymatic solution. The blood sample is drawn into the strip from at it base using capillary action ready for optical testing.

Capillary action is an intermolecular force which causes the movement of liquid (like blood) through tubular structures. When blood is placed against the opening of the test-strip, a concave meniscus is formed. The surface tension then pulls the blood through pre-made grooves until there is a sufficient mass preventing further movement. It is important to note that there are many factors which can influence or even prevent the flow of blood, such as mass, weight, gravity, surface tension, groove shapeliness and surface porosity. The 4 designs show how the newly circular test-strip was re-designed taking into account these important rules.

## FIRST GENERATION DIGITAL GLUCOSE METER USING TWO ANALYSIS METHODS

*Reflectance photometry and electrochemical technologies*

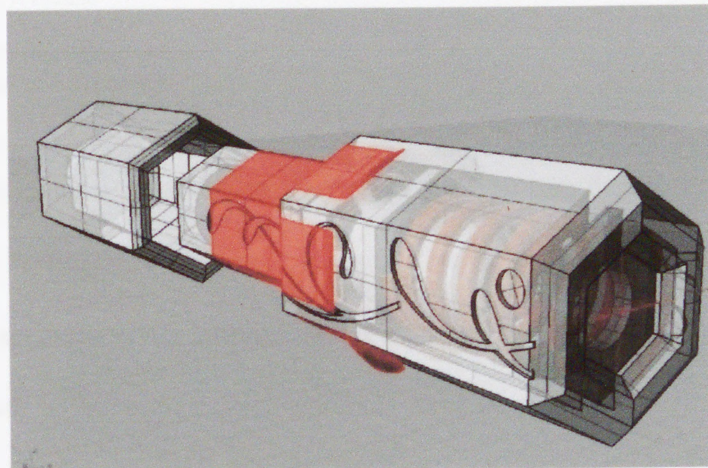

The following equation breaks down the reflectance process after a sample of whole-blood is chemical reacts with a glucose sensitive solution containing an enzyme catalyst and dye:

Whole-Blood Sample Containing Glucose  
+ Solution(X) & Enzyme Catalyst  
+ Dye & Enzyme Catalyst

**Result: Coloured Produced (Ready for Reflectance Photometer)**

The new glucose-meter is designed to measure the rate of change in the colour product over a set period of time. A small electronic module that measures the electrons generated by the enzymatic reaction process of the reagent, as opposed to measuring the colour by-product caused by the reaction of the reactive enzyme. Many reliable and easy-to-use blood glucose monitoring systems on the market today still use this technology, eliminating the need for wiping and timing. The following equation breaks down the amperometry processes after a sample of whole-blood has been obtained:

Whole-Blood Sample Containing Glucose  
+ Solution (Y) & Enzyme Catalyst

**Result: Captured Electrons ( $e^-$ )**

(The more glucose that is present in the sample the more electrons will be recorded.)

**Fig. 117 (Previous Page)**

First Generation Digital Glucose Meter using Two Analysis Methods  
Exploded view

Note: The lancet developed here uses a micro-syringe to draw a sample of whole blood into a controlled and sterile space of reaction chamber made ready for analysis using amperometric technology. To immobilise the enzymes self-assembled monolayer's are used so the sensitivity and reproducibility of the electrochemical response will improve.

2009

© Leon B M Williams

Centre for Jewellery Research,  
Royal College of Art, London

The newly developed glucose-meter was based on two digital technologies known as 'reflectance photometry' and 'electrochemical amperometry', to measure accurate concentration levels of glucose in a sample of whole-blood. Both technological advancements have been regarded over the past 30 years as important progressions in the development of reliable, high performance self-monitoring glucose systems<sup>56</sup> and for this reason were best suited to this project.

Blood glucose tends to be measured by weight, in grams, or by molecular counts, in moles. The unit millimoles per litre/litre (mmol/L), is the world standard unit for measuring blood glucose levels, and is used universally except in the United States, where milligrams per decilitre is preferred (mg/DL).

Most glucose meters today are able to convert these two units of measurement. To further understand the conversion of mmol/L to mg/DL

---

<sup>56</sup> More information can be found at [www.lifescan.com/pdf/hospital/eb\\_110a.pdf](http://www.lifescan.com/pdf/hospital/eb_110a.pdf) titled 'a comparison of reflectance and electrochemical technologies'. Later generation glucose meters incorporated electrochemical technology known as amperometry. In the glucometer the amperometric measurement technique is applied. This application is for home-use and is less painful than other applications.

and vice versa, I have put together the following conversion chart used by the new glucose-meter.

TABLE 5: CONVERSION CHART-MMOL/L TO MG/DL																					
mmol/L	2	3	4	5	6	7	8	9	10	11	12	13	14	15	16	17	18	19	20	21	22
mg/DL	35	55	70	90	110	125	145	160	180	200	215	235	250	270	290	305	325	340	360	380	400

Note: The orange blocks are indicative of a non-insulin dependent adult. To convert mmol/l of glucose to mg/dl, multiply by 18; and to convert mg/dl of glucose to mmol/l, divide by 18. Both conversions are specific to glucose alone and cannot be performed with other substances like urine and plasma. The mg/DL readings are converted to the nearest (5), whereas mg/DL to mmol/L are converted to the nearest 1 for consistency reasons.

Most blood glucose meters developed for home use today provide a reading with a 10-15% error margin when used in ideal conditions. For example, a reading of 10 mmol/L could in fact be in the range 9 to 11. This means that no two results will ever be exactly the same, even when checks are performed consecutively, one directly after the other<sup>57</sup>. Table 6 provides more detail on tolerances and guidelines in the making and testing of the second generation glucose meter-device:

<sup>57</sup> Most patients accept this margin of error because the results are considerably more accurate than other self-monitoring glucose alternatives and generally would not influence the final treatment decision or insulin dosage made by the patient. For instance, a reading of 5.5mmol/L with a difference between 5.1 and 5.9mmol/L might not alter the treatment plans, or the measured dose of units of insulin overall.

**TABLE 6: TOLERANCES & TECHNICAL SPECIFICATIONS FOR THE NEW GLUCOSE METER**

Result Range	1.1 - 33.3 mmol/L
Calibration	Plasma- equivalent
Sample	Whole-blood
Sample size	1 micro-litre (µl) approx
Test holding time	1 – 3 seconds
Assay method	Glucose biosensor (Reflectance and Amperometry)
Meter power source	Rechargeable 3.7 Volt lithium-ion battery
Unit of measure	mmol/L
Memory	500 Test Memory capacity
Automatic shutoff	5 minutes after last action
Booklets	Quick reference guides into the device as standard.
Operating ranges	Temperature: 6 - 44°C
	Altitude: up to 3048 meters
	Relative humidity: 10—90%
	Haematocrit: 30 - 55%
Blood Sample	Adjustable Blood Sampler-which together are more comfortable for your fingertips. You also have the option to test on your forearm*-so you can give your fingers a rest.
	Fine needle penetrates a few mm under the skins surface where blood is drawn through capillary action. Accurate results are then measure in less than 5 seconds.
	Date & Time
	No Manual Cleaning Necessary
	500 Test Memory capacity
	Compact Meter Size & Weight
	Easy to read colour oled/lcd screen
Small and sleek	

To ensure seamless integration and wireless communication between the glucose-meter and a PC or laptop, additional improvements were made to the BABY-BLUE Software. The next stage was to develop a new and improved insulin delivery system (IDS). Fig. 118 shows the procedural steps and difficulties of administering insulin.

**Fig. 118 (Next Page) >>**

45 Procedural Steps to Prepare, Make Ready, and Administer Insulin using a Traditional Insulin Delivery Pen





2008

Leon B M Williams

Centre for Jewellery Research,  
Royal College of Art, London





45 PROCEDURAL STEPS TO PREPARE, MAKE READY, AND ADMINISTER INSULIN USING A TRADITIONAL IDP

0:00:14



1. check pen      2. remove cover      3. grip needle cap      4. unscrew

0:01:32



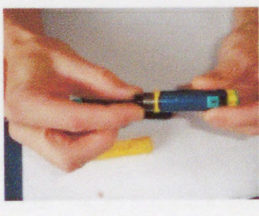

5. safely dispose of needle      6. unscrew mechanism      7. separate mechanism      8. remove empty insulin vial

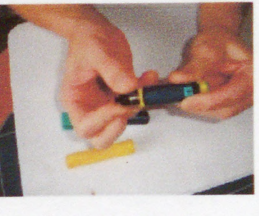
0:02:02



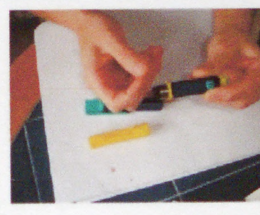

9. safely dispose of vial      10, 11, and 12. retract working mechanism. *action: (push, pinch and twist)*

0:02:45





13. check for damage      14. open box of insulin vials      15. select new insulin vial      16. detach from blister pack

0:03:22

17. insert new insulin vial      18. hold and re-position      19. screw back mechanism      20. check for loose fittings

0:04:05

21. open box of needles      22. check needle size      23. select needle      24. peel-back safety strip

<< continues from previous page

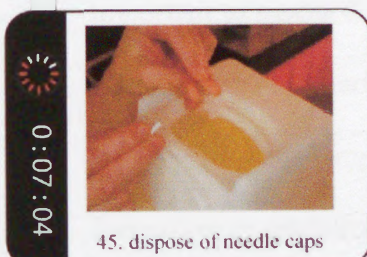
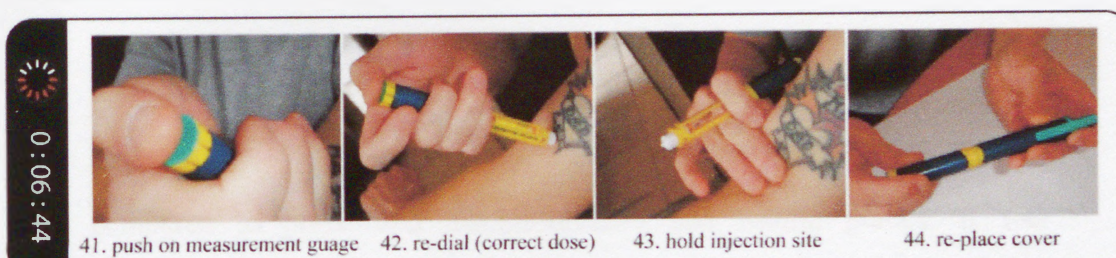
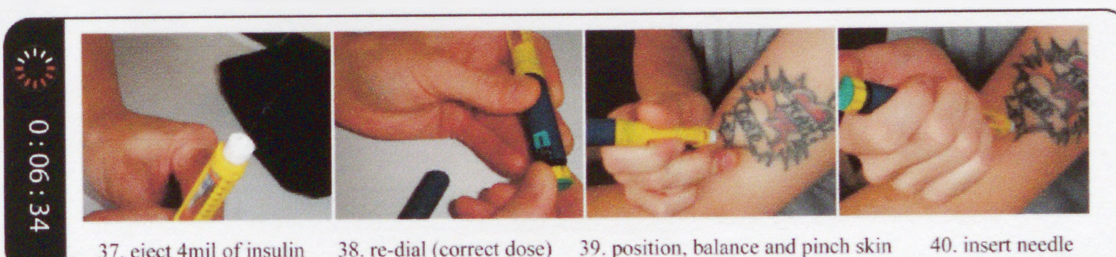
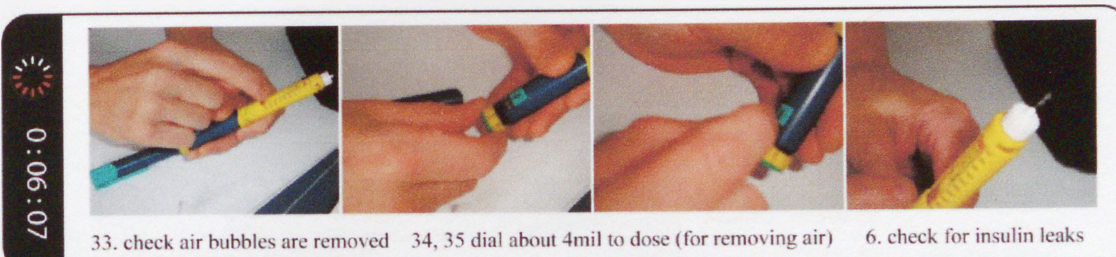
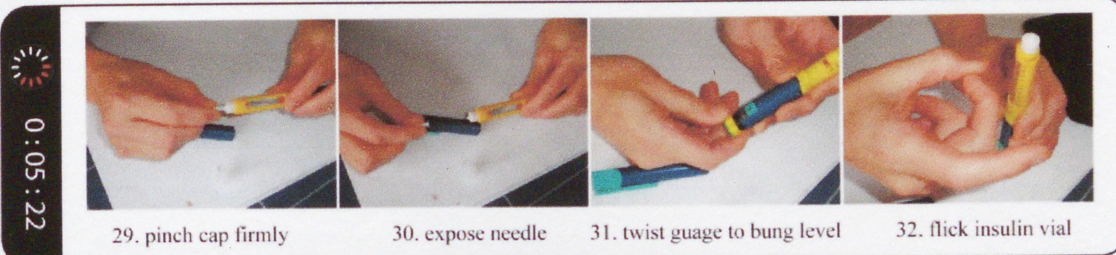
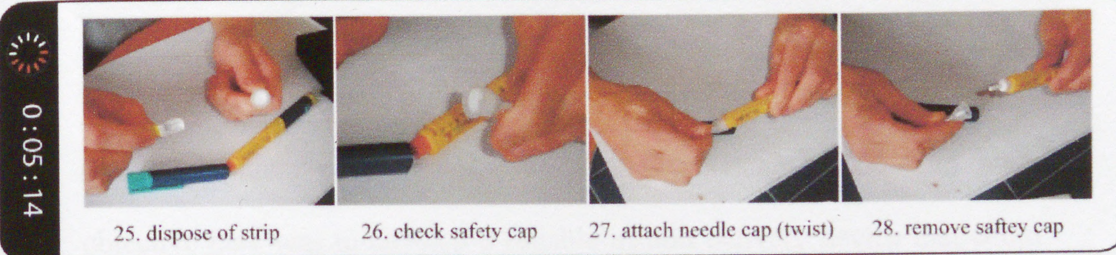

A participant (with Type 1 diabetes) agreed to be shadowed in their home/work place for a period of 24 hours so that I could acquire a better understanding of the daily requirements and demands of taking insulin at least four times a day. The participant was asked to perform the self-administration of insulin in normal time whilst describing his actions. Images 1 - 45 account for these main steps of preparing, making ready and administering a single dose of insulin. The entire sequence takes more than seven minutes.



## A NEW INSULIN DELIVERY SYSTEM (IDS)

- Syringes and Pens -

This part of the research outlines some of the key decisions that influenced the development of a new Insulin Delivery System (IDS). The main objective here was to develop a reliable insulin delivery device that could be carried on the body at all times, whilst complementing the home glucose monitoring system (HGMS) and BABY-BLUE technologies.



**Fig. 119**

©Three Insulin Delivery Devices

*Top:* AutoPen 24 – developed for patients with limited grip

*Middle:* NovoPen

*Bottom:* Manual Syringe and Needle  
2007

Photography by Leon B M Williams

Centre for Jewellery Research,  
Royal College of Art, London

The three insulin delivery products were selected for their potential portability. They were practical, cheap and relatively easy to manage compared to pressurised insulin-injectors and insulin pumps. It was important to assess the positive qualities that characterised each insulin pen type, whilst considering their associated defects and analysing how these issues could be improved to provide an alternative IDS system and increasing its usability for the patient. Figs. 120 -121 show the initial design and prototype stages.

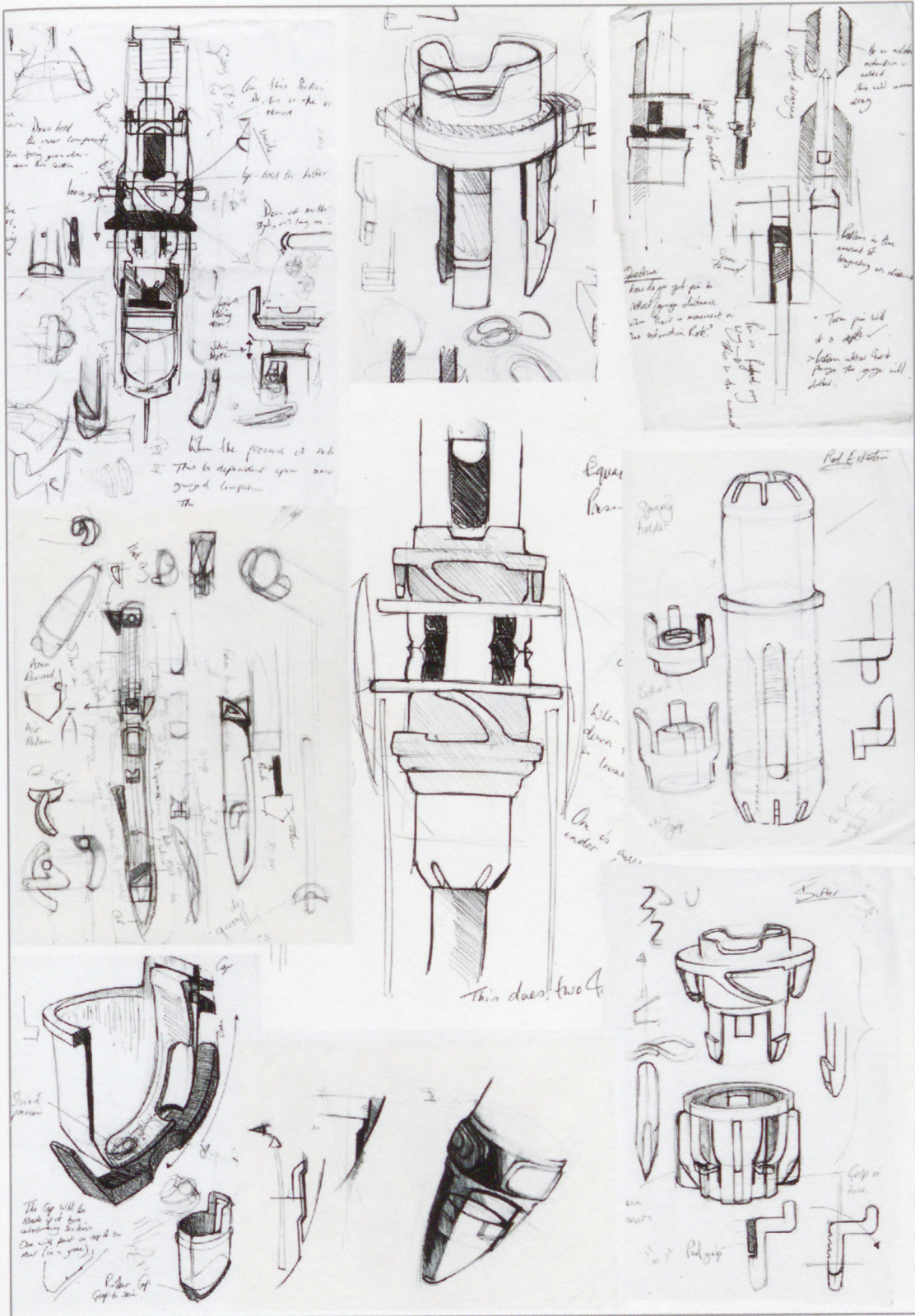
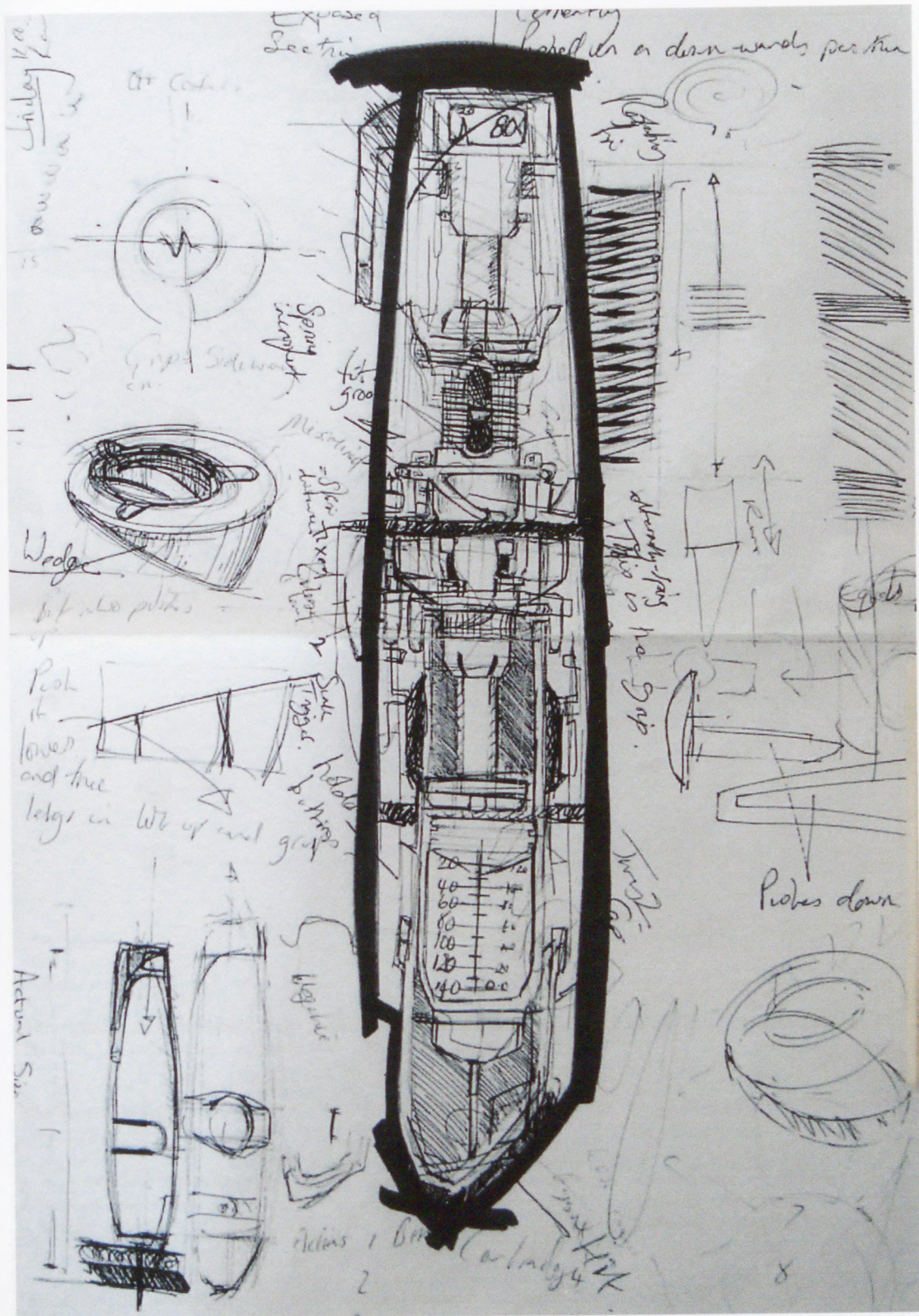

**Fig. 120**

A Collection of Design Sketches that Challenge the Pragmatic Mechanical Problems to Hold, Carry and Stabilise the Flow of Insulin as it is Administered by the Patient.  
2008

© Leon B M Williams

Centre for Jewellery Research,  
Royal College of Art, London



**Fig. 121**

Final Design Sketch of the Newly Developed Insulin Delivery Pen. 2008

© Leon B M Williams

Centre for Jewellery Research,  
Royal College of Art, London

**INSULIN DELIVERY PEN**  
(A view of the mechanical working)

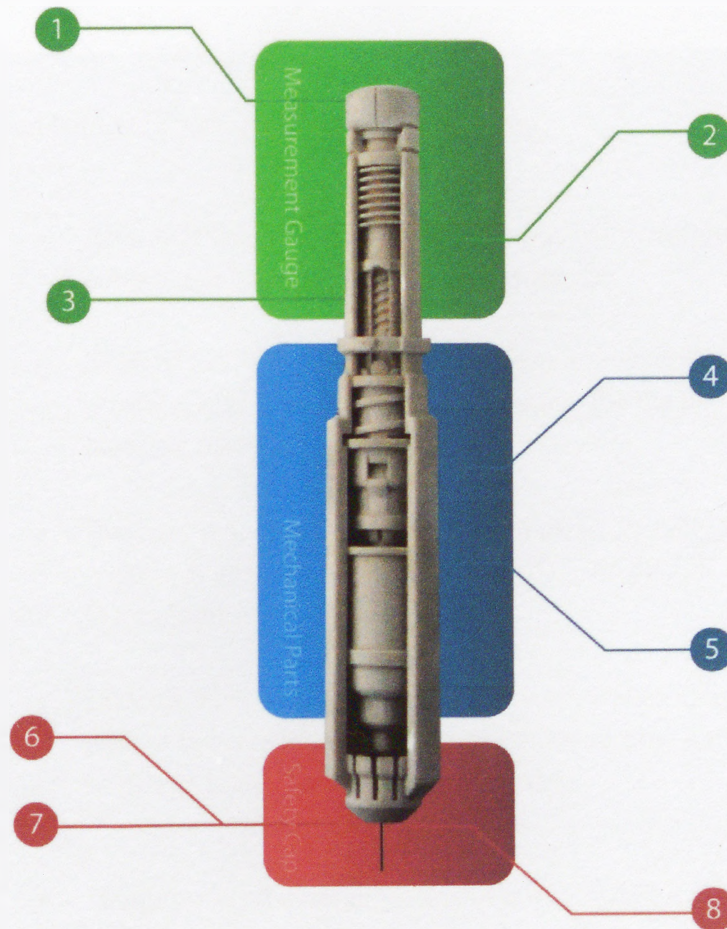

This figure details a prototype of the improved insulin pen. For purpose of clarity, all design changes made to the insulin pen can be seen in one of three colour-coded groups. These are:

**The Measurement Gauge**  
(as shown in green)

- 1. Improved dose measurement gauge
- 2. A spring loaded retractable pin
- 3. Tubular case

**The Mechanical Parts**  
(as shown in blue)

- 4. New mechanical trigger
- 5. Vial chamber

**The Safety Cap**  
(as shown in red)

- 6. Safety cap,
- 7. Needle guard
- 8. Needle locking mechanism

All of these design changes were implemented to improve the effective use of the device.

**Fig. 122**

Insulin Delivery Pen

3-Dimensional rapid prototyped model showing the inner working of the newly developed insulin deliver pen, Z-CORE technology 2008

© Leon B M Williams

Centre for Jewellery Research,  
Royal College of Art, London

At this stage a decision was made to reject the prototype. Unfortunately, its complex design proved ineffective in delivering accurate doses of insulin.

Listed here are some of the main reasons why.

- Although the prototype worked, it was over-designed, component heavy, and difficult to manage.
- Most of the 30 mechanical parts were human operated – meaning that there were too many ways for the patient to measure inaccurate insulin doses.
- The new insulin pen would be difficult to digitally control, making it unsuitable for integrating BABY-BLUE technologies.
- Like all other insulin pens, this device would require the patient to reload a new insulin cartridge or attach a new needle at least two or three times a day.
- Handling in an emergency could prove difficult if the patient experiences shock, hypoglycemia, or hyperglycemia.
- The mechanical parts were too bulky to be used as a product carried discreetly on the body.

It seemed that the challenge here was not only to invent a better device, but to simplify and re-think new ways to improve the insulin delivery system, in order to make it easier to manage in times of need.

The additional key objectives that guided development were:

- To implement new safety features that would improve the handling of sensitive parts of the insulin delivery system or susceptible to damage, such as the needle or insulin.
- To develop a more compact mechanical device that could be carried on or close to the body for quick accessibility.
- To devise a more practical and ergonomic insulin delivery system that could be easily used by everyone in cases of emergency.
- Finally, to develop a way to store and make use of data about the device and the patient. This includes making the device compatible with all BABY-BLUE technologies.

The next few sections break down some of the most important decisions that guided the development of a new IDS (incorporating a new measurement gauge, mechanical movement, needle related improvements) including a new safety cap (to prevent needle stick). Each new development was designed to tackle some of the key objectives outlined and create a more practical and fully functional insulin delivery system (IDS) supported by BABY-BLUE technologies.

## A NEW MEASUREMENT GAUGE

- Accurate Dose Measurements -

Each type of insulin comes in different concentrations and unit sizes; unit sizes are available from 40, 100, 500, and 1000 units per millilitre. The dose and concentration is dependent on the requirements of the individual patient, however insulin is most commonly distributed today in 100 units per millilitre, as the same syringe is used two or three times daily. Fig. 123 shows the design build of the development of a new retractable measurement mechanism, designed to discreetly fit inside the inner structure of a bung within a typical 100 unit insulin vial. The periscopic feature allowed for accuracy on dose (1 full twist = 25ml) and also allows patients to readjust their dosage prior to injection, which is not available on any current insulin delivery system.



**Fig. 123**

Rapid Prototyped Measurement Gauge for Use as  
Part of the New Insulin Delivery System IDS  
2008

Envision-technology  
© Leon B M Williams

Centre for Jewellery Research,  
Royal College of Art, London

## A NEW COMPACT BUNG WITH INTERGRATED PLUNGER DESIGN

ORIGINAL BUNG DESIGN

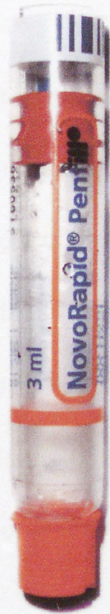

NEW BUNG DESIGN

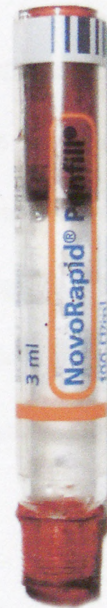
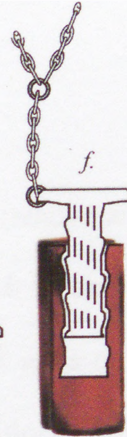

a.



b.



c.

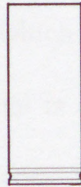

d.



e.

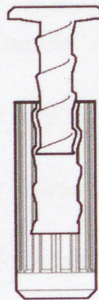

1. READY FOR USE

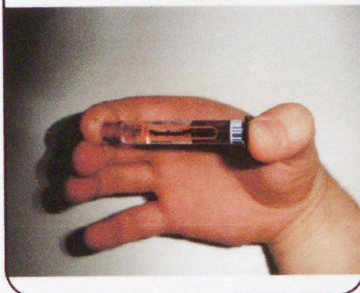

2. RETRACT PLUNGER



3. PLUNGE BUNG

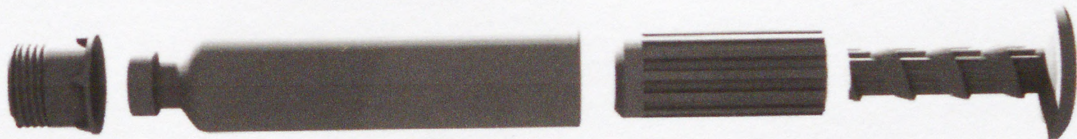

Images (a. through f.) show *(at a glance)* the key evolutionary stages that led to the development of the new bung and plunger mechanism. The main objective here was to develop a device that could be easily managed in time of need. Additional grip was added to the plunger-head to accurately measure insulin. Each revolution accounting for half a ml of insulin. This makes it easy to understand and use by the patient in times of need.



<< **Fig. 124 (Previous Page)**

New Compact Bung and Integrated Plunger

Design

Rapid prototyped parts (Envision-  
technology)

2008

© Leon B M Williams

Centre for Jewellery Research,  
Royal College of Art, London

A second new feature was added to later versions to remove any trapped air bubbles. This is achieved mechanically, as once the back section of the bung is fitted, it will automatically discharge approximately 4 units of insulin and a further 2 units before every other use, to release any air pockets that might have formed within the insulin and which could later cause serious side-effects. This ensures that the needle and vial is clear of blockages, whilst preventing any discrepancy in dose measurements.

## A NEW SAFETY-CAP DESIGN

- Needle Related Issues -

There are many forms of needle phobia, from trypanophobia - the extreme fear of medical procedures involving hypodermic needles to, iatrophobia - a phobia of seeking medical advice from a doctor or medical expert. These phobias can affect both adults and children at any stage of their lives, and if not addressed could cause serious complications for those who develop Type I diabetes. For those people, a fear of needles could prevent the patient administering important daily treatments. A survey was conducted at the Royal College of Art in November 2007. It shows most participants declaring their personal fear of needles.



**Fig. 125**

35 Participants Discussing the Various  
Types of Needle Phobia.

2007

© Leon B M Williams

Centre for Jewellery Research,  
Royal College of Art, London

The new technologies within this project are designed to ameliorate many fears that are inherent in the use of many medical products.

## THE DEVELOPMENT OF THE DISPOSABLE NEEDLE SAFETY GUARD

- Protecting the Body -

In 1992, Becton, Dickinson and Company manufactured the Vacutainer Safety-Lok Blood Collection Set, to protect the patient from needlestick<sup>58</sup> when drawing blood. By the early part of 21st century, Becton, Dickinson and Company launched a nationwide 'safety compliance initiative' programme to raise awareness of the potential risks involved in the preparation and process of administering insulin when using diabetes devices. The objective was to encourage healthcare institutions to comply with and maintain a high level of awareness of the necessary changes in engineered devices being used in a clinical environment, and if qualified to do so, to give proper, adequate, and up-to-date advice to their patients.

Today, needle-stick injuries are very common amongst healthcare professionals and diabetes Type I patients<sup>59</sup>. Most needle-stick injuries are caused by insufficient safety-guards or loose cap attachments on a number of medical devices, such as the insulin-pen. Even the current self-loading insulin-pens have this design flaw. When replacing the needle or transporting the insulin-pen it is easy to unintentionally tap the needle. This can cause damage to both the needle and the person carrying it, resulting in an unusable pen and leaving the patient with no way of accessing their medicine.

---

<sup>58</sup> Needlestick is the act of involuntary pricking or stabbing the self or other with the needle tip without prior awareness when carried or transported on or close to the body.

<sup>59</sup> Lee, J.; Botteman, M.; Nicklasson, L.; Cobden, D. & Pashos, C. (2005) *Needlestick Injury in Acute Care Nurses Caring for Patients with Diabetes Mellitus: A Retrospective Study*, Current Medical Research and Opinion, Vol 21, no. 5, May 2005, pp. 741-748

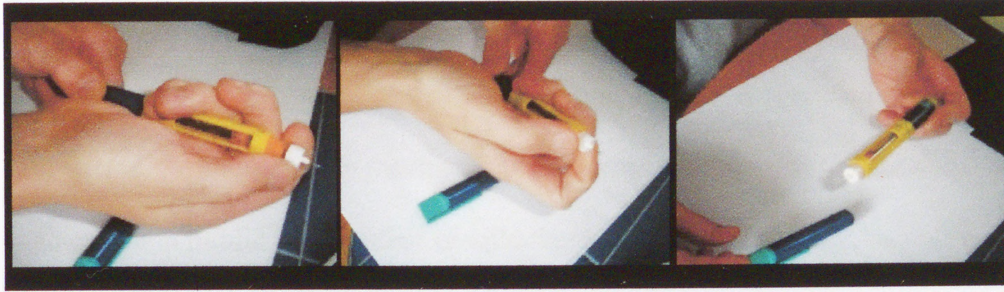

**Fig. 126**

Using a Typical Insulin Device  
Participant in this sequence is  
highlighting the practical difficulties  
of using a typical IDS and needle  
2008

© Leon B M Williams

Centre for Jewellery Research,  
Royal College of Art, London

Figures detailed within the article, 'The cost of needle-stick injuries associated with insulin administration', (2008)<sup>60</sup> state that more than £600,000 per annum is spent by the NHS in the U.K on treatment and associated costs due to needle-stick injuries. If a suitable and cost efficient device was implemented, it could help prevent future injuries and ameliorate anxiety and stress to patients or carers.

One consideration to improve the current insulin delivery system was to develop a disposable needle, cap and integrated safety features, to overcome the serious problem of keeping the inner-working of the device clean for use, and make it safe for disposal. Traditional insulin pens can be notoriously cumbersome to clean, as constant leaking can cause poorly fitted needles, aggressive agitation or damaging of the pen, and rapid

<sup>60</sup> Trueman, P.; Taylor, M.; Twena, N. & Chubb, B. (2008) *The Cost of Needlestick Injuries Associated with Insulin Administration*, British Journal of Community Nursing, Vol 13, Issue 9, 05 September 2008, pp. 413 - 417

temperature change can build up a distinctive scent, making the experience of carrying or using the insulin pen at home or in public unpleasant. One aim was to develop a safety mechanism that allowed the patient to take their medication in public without fear of onlookers judging them.

Figs. 127 and 128 demonstrate a new needle guard invention, designed here to help reduce the risk of needle-stick and protect the patient and needle from damage when being carried.

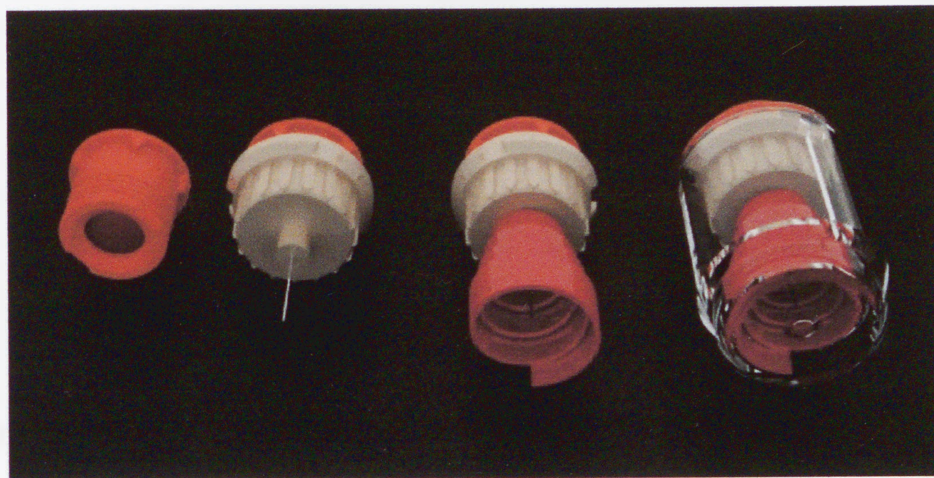

**Fig. 127**

Design Simulation Detailing the New Disposable Needle Safety-Guard Invention. Developed here to reduce the risk of needle-stick injuries.

2008

© Leon B M Williams

Centre for Jewellery Research,  
Royal College of Art, London

The spiral spring helps mask the needle when being injected into the body, making it more acceptable when used in public. If the newly developed safety guard was applied to future medical devices it could ameliorate many social phobias directly associated with taking medicines in public spaces.



**Fig. 128**

Mechanical Simulation Showing the Newly Developed Safety-Cap Design in its Active and Non-Active State.

*(Left image)* shows the cap locked

*(Right image)* shows the needle in a plunged position.

2008

© Leon B M Williams

Centre for Jewellery Research,  
Royal College of Art, London

The bowl-like clear cap was designed to catch and collect any unused insulin that leaks from the needle when carried close to the body. Traditional insulin pens, such as the 3.0ml NovoPen, Novolet, AutoPen, and Lilly Saline Pen tend to dribble a small amount of insulin from the tip of the needle when being withdrawn from the injection site. The new safety-cap design allows the patient to stabilise the IDS and needle. This 'hold' time ensures that the needle can be held in the body for a prolonged period of approximately 5 – 10 seconds, rather than retracting it immediately after the insulin has been injected. However, this 'hold in time' may differ slightly from one person to another depending on the units of insulin injected, rate of injection, and the location on the body that is being injected into. It is also not abnormal for the patient to experience leakage from the skin (at the

injection site) when the needle has been withdrawn, however if the patient finds that both of these problems are occurring at the same time, there is a high chance that the insulin dose is not accurate and that the loss of insulin could cause discrepancies between what is being measured and that actually being used, leading to unstable blood glucose levels. The new mechanism reduces the chance of unwanted dirt blocking or entering the device via the needle. The new design allows the needle to detach quickly from the IDS in the event of an emergency. When the safety cap is removed and disposed of, the working parts of the insulin device are kept clean. The safe-guard-needle shown in Figs. 127-128 could be used to provide confidence to the patient that all sharp edges of a needle and syringe are not openly exposed, reducing the chances of needle-stick to the patient or damage to the needle tip.

## PREVENTING NEEDLE SHIFT

*-Developing a Tilt-Sensor to Monitor and Control Needle-Movements when Administering Insulin-*

When learning how to inject insulin subcutaneously (under the skin) for the very first time, the patient could experience nervous flinching of the muscles brought on by the stressful anticipation of a sharp needle penetrating the skin (a mild form of Aichmophobia –fear of needles). This can prove difficult as the chances of injecting insulin directly into a vein, muscle, bone or fleshy tissue is increased, which can prove painful and dangerous. On a pragmatic level, most experts can only advise their patients to adapt, using relaxing techniques to control the administration of insulin. Although this problem can be overcome through extensive practice, it requires a great deal of trial and error<sup>61</sup>.



**Fig. 129**

The Sequence Shows a Participant Administering Insulin using the Novo-Pen. The image shows the difficulty of handling the device whilst trying to avoid sensitive parts of the body. The three images show how the patient balances the pen whilst positioning the needle.

2007- 2008

© Leon B M Williams

Centre for Jewellery Research,  
Royal College of Art, London

<sup>61</sup> Learning to monitor diabetes is vital to sustain a healthy quality of life. Most diabetic patients need to train both their body and mind to deal with the effects of diabetes, so they can identify signs before any permanent damage is done to the body. Expert Paula Brisco *in the Diabetes questions you have...Answers you need*, Wings Books, New York, 1995, p.12 states, '*...you must learn to control your diabetes. 'Don't let it control you...'*'<sup>61</sup> which is why self-care is an absolute necessity.



*So, why is this a problem?* The learning period is a key time for patients, but also one which can, for some, be traumatic. The needle is vulnerable, even the slightest tensing could lead to the shifting of the needle inside the body, contributing to a displacement of body mass and leading to tearing of tissue beneath the skin's surface. Fig. 130 shows the development of a new needle-tilt sensor technology (developed here) designed to monitor slight needle movements, giving the patient more control over the direction that the needle is taking when inserted beneath the skin.

The main benefit of using the needle-tilt sensor is to give the patient a clearer understanding of what is going on beneath the skin's surface and the confidence that they are administering their medication effectively. The tilt-sensor invention makes use of quantum tunnelling composite material to accurately measure slight changes in needle movement. The next development was to build into the device a LCD or OLED screen for people with visual difficulties.

DEVELOPMENT OF THE NEEDLE-TILT SENSOR  
*newly invented pressure sensor for use as part of the insulin delivery device*

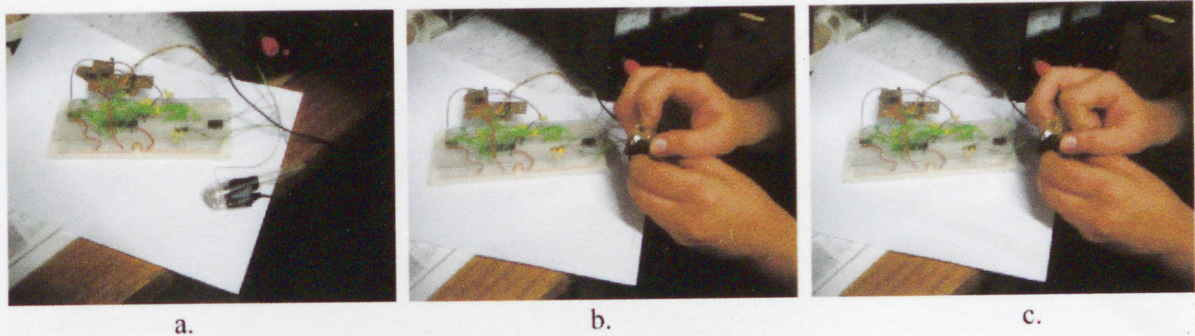
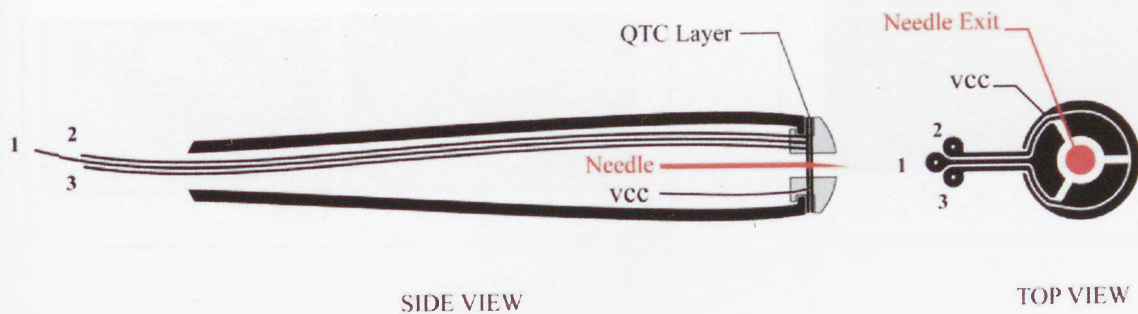

The new invention was developed to give a patient the ability to record accurate needle movements when administering insulin. The design shown here demonstrates how Quantum Tunnelling Composite (QTC) could be used to measure accurate pressure readings. QTC typically comes in sheet form. When cut into the three shapes (as shown in the top view) it can be used to make up part of an electrical sensor that is sensitive to force and weight. When a load is applied to the QTC, its material properties change. The electrical resistance can be measured over flat or curved forms like the round tip of an insulin pen. Images (a, through to c.) show the device being trial tested.

**Fig. 130**

First Generation Needle-Tilt Sensor

Rapid-prototyped pen with quantum tunnelling composite pressure sensor developed to monitor needle-movements when administering insulin subcutaneously

2008

© Leon B M Williams

Shadow Robotics and Royal College of Art, London

## TRIAL TESTING THE TILT-SENSOR

*newly invented tilt and pressure-sensor for use as part of portable devices*

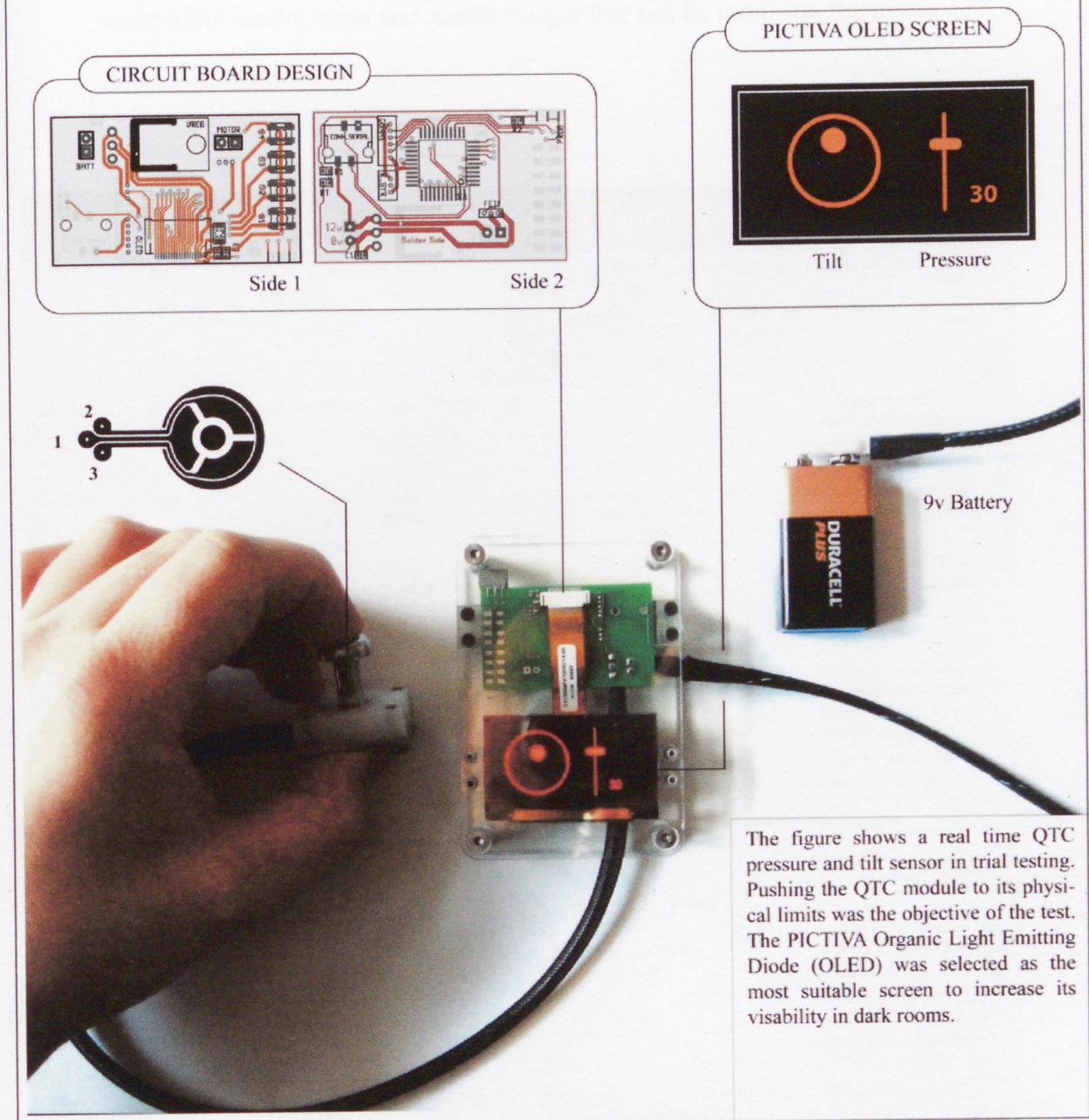

**Fig. 131**

Trial Testing the Tilt Sensor

Second generation needle-tilt sensor with a tiger-orange organic light emitting diode screen

2008

© Leon B M Williams

Shadow Robotics and Royal College of Art, London

There are many insulin types, such as; Short-Acting-Soluble; Long-Acting; Bolus Analogue; Basal Analogue; and Mixtures. Tables 10 and 11 show all compatible insulin types and needle gauges that can be used with the newly developed IDS.

**TABLE 7: COMPATIBLE INSULIN TYPES FOR USE WITH THE NEW IDS**

Insulin	Active Ingredient	Administer Daily	Average Response	Average Working Time After Injection (mins)	Average Lasting Effective Time (hrs)	Maintain Body's Basal Insulin	Other Information
Humalog	Insulin Lispro	As directed	Rapid	15	32 - 5	N/A	Combines with intermediate / long acting insulin at meal times
Lantus	N/A	Once	Long Acting	N/A	Long Acting	Yes	Combines with short acting insulin at meal times
Levermir	N/A	Twice (dependant on patients)	Long Acting	N/A	Long Acting	Yes	Combines with short acting insulin at meal times
Actrapid	Human Soluble Insulin	Before meals as directed	Fast	30 - 60	8 (dependant on dose)	N/A	Combines with intermediate / long acting insulin at meal times - Works like natural insulin
Novorapid	Insulin Aspart	Before meals as directed	Fast	310 - 20	33 - 5	N/A	Injected before or immediately after a meal
Venosulin	Neutral / Soluble Insulin	15-20 mins before meals as directed	Fast	30 - 60	8	N/A	Taken in conjunction with other recommended insulin
Humulin M3	Human Biphasic isophane insulin	Before meals as directed	Intermediate	30 - 60	8 (dependant on dose)	N/A	Takes longer to be effective / last longer than average - Combination Insulin
Hypurin	N/A	Before meals as directed	Intermediate	120	18- 24	N/A	Commonly used with short acting insulin
Insuman	Isophane Insulin	Pre-loaded pen	Intermediate	30 - 60	8 (dependant on dose)	N/A	N/A
Insulatard	Human isophane insulin	Pre-loaded pen	Intermediate	N/A	N/A	N/A	Helps to control blood glucose throughout day
Ultratard	Human insulin zinc suspension	Pre-loaded pen	Long Acting	N/A	Long Acting	N/A	Helps to control blood glucose throughout day
Mixtard	Human Biphasic isophane insulin	Pre-loaded pen	Rapid / Intermediate	N/A	N/A	N/A	N/A

**TABLE 8 : COMPATIBLE NEEDLE GAUGES USED AS PART OF THE NEW IDS**

Needle Gauge	Nominal OD (mm)	Nominal ID (mm)	Nominal Wall (mm)	Length (mm)	Recommended Injection Angle	Pinch Skin' Technique Recommended	Children under 12	Teenagers (12-18) - Average BMI	Teenagers (12-18) - Overweight BMI	Slim Adults	Adults - Average BMI	Adults - Overweight BMI
28	0.356	0.165	0.089	12	Vertical or Angled	Yes	No	No	No	No	No	Yes
28	0.356	0.165	0.089	12.7	Vertical or Angled	Yes	No	No	No	No	No	Yes
29	0.33	0.165	0.076	10	Vertical	No	No	No	No	No	No	Yes
					Vertical or Angled	Yes	No	No	Yes	No	Yes	Yes
29	0.33	0.165	0.076	12	Vertical or Angled	Yes	No	No	No	No	No	Yes
29	0.33	0.165	0.076	12.7	Vertical or Angled	Yes	No	No	No	No	No	Yes
30	0.305	0.14	0.076	8	Vertical	No	No	No	Yes	No	Yes	Yes
30	0.305	0.14	0.076	12	Vertical or Angled	Yes	Yes	Yes	Yes	Yes	Yes	No
					Vertical	No	No	No	Yes	No	Yes	Yes
					Vertical or Angled	Yes	Yes	Yes	Yes	Yes	Yes	No
31	0.254	0.114	0.064	5	Vertical	No	Yes	No	No	Yes	No	No
					Vertical or Angled	Yes	Yes	No	No	Yes	No	No
31	0.254	0.114	0.064	6	Vertical	No	Yes	Yes	Yes	Yes	Yes	No
					Vertical or Angled	Yes	Yes	No	No	Yes	No	No
31	0.254	0.114	0.064	8	Vertical	No	No	No	Yes	No	Yes	Yes
					Vertical or Angled	Yes	Yes	Yes	Yes	Yes	Yes	Yes

## DEVELOPING A PERSONALISED MANAGEMENT TOOL FOR THE BABY-BLUE SOFTWARE

*-Personalised Management Software-*

Normoglycemia is the medical term used to describe the presence of a normal concentration of glucose in the blood. Most diabetic patients strive to maintain this state of glucose, which is where medical jewellery can help. Currently, most diabetic patients need to learn how to structure, plan, and manage their daily lives to accommodate their diabetes, regulating their body's blood-sugar-levels by injecting measured doses of insulin in conjunction with a regimented exercise programme. Here a new personalised management tool was added to the existing BABY-BLUE software. It was designed to give diabetic patients a quick overview of their personal health-care, with the potential of being part of a larger patient community.

RECOMMENDED LOCATIONS ON THE BODY FOR THE ADMINISTRATION  
OF INSULIN MEDICINE USING MEDICAL JEWELLERY

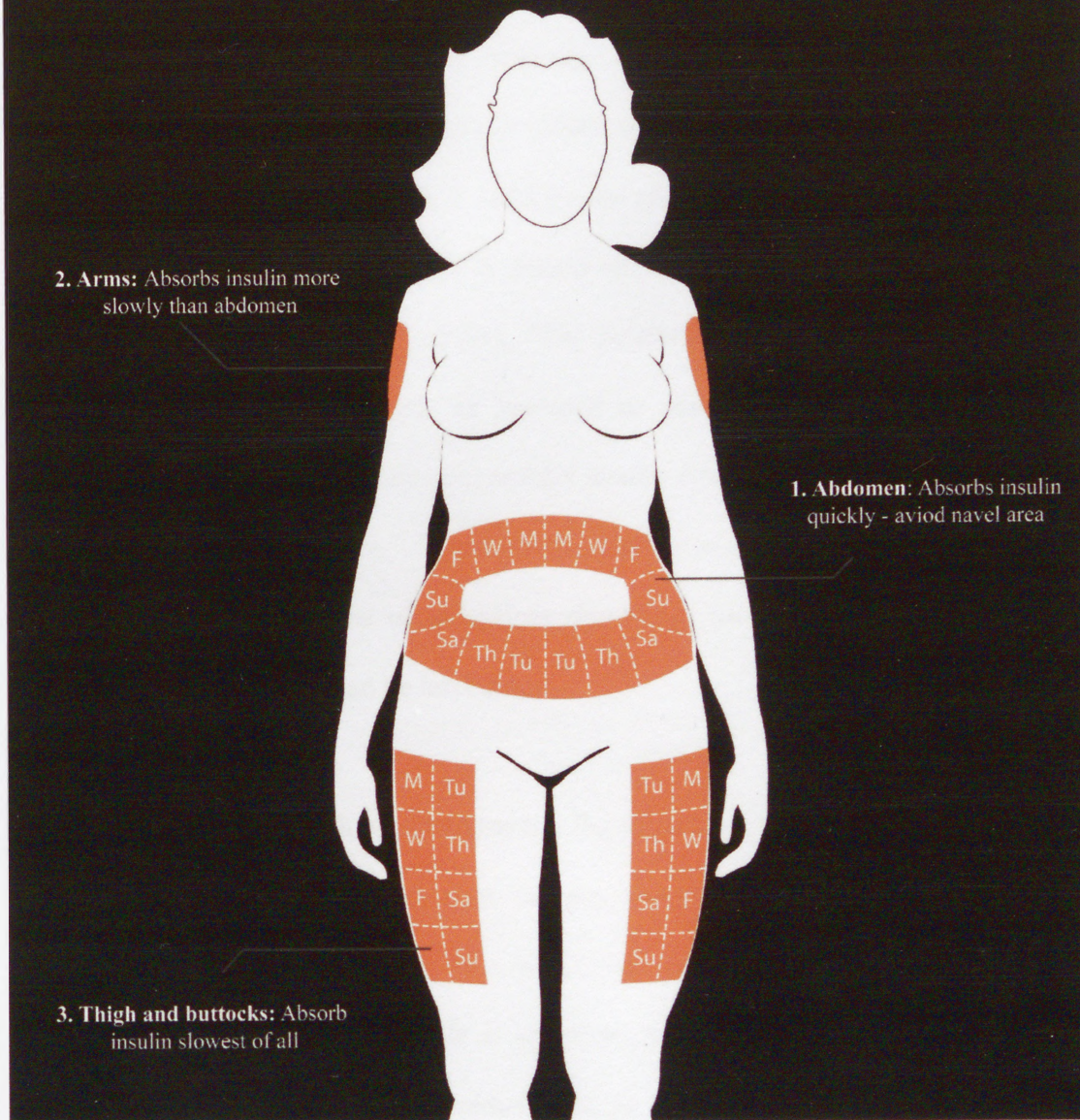

**Fig. 132**  
Recommended Locations on the Body for the  
Administration of Insulin using the Newly  
Developed IDS  
2009  
© Leon B M Williams

Centre for Jewellery Research,  
Royal College of Art, London

## SUMMARY

- Overview of the HGMS and IDS -

The insulin delivery device industry is rapidly changing. The next generation of insulin products are reliant upon new medical developments to improve the way insulin is used by the patients in a clinical and home setting. A point of view that is shared amongst many medical experts is stated by Kristy Barnes<sup>62</sup> (2006), "*The insulin delivery devices thriving in today's market will slowly be replaced as new and better technologies continue to rise ... For current market leader, Novo Nordisk, this threat is particularly dangerous.*". I believe that industries are vulnerable to change and even the smallest of influences should not be overlooked, otherwise leading companies can be left behind.

Becton Dickinson have commanded the majority of the insulin delivery products industry for the past century, developing and selling various needles, syringes, and vials on a world-wide scale until the introduction of the Novo-Nordisk Pen<sup>63</sup>. It is important to note that Novo Nordisk is momentarily in the same predicament as was Becton Dickinson in the 1990s. The arrival of the Novo-Nordisk pen began to rise in popularity, eventually dominating the European market as the most preferred insulin delivery device. The Novo-Pen will eventually be superseded by the next generation of insulin delivery systems. Although other insulin jet injectors

---

<sup>62</sup> Barnes K., (2006) Insulin delivery devices - an industry under threat, *In-PharmaTechnologist insulin series* [online] [www.in-pharmatechnologist.com](http://www.in-pharmatechnologist.com) [accessed 14/08/2007]

<sup>63</sup> Novo Nordisk, currently dominate the world insulin device market as holds approximately 70% share of the worlds market of insulin pen devices.



systems and insulin pumps have been developed for many years, they have not yet managed to appeal to a mass audience, for both practical and financial reasons. Other companies such as Alkermes, Eli Lilly, Disetronic, Generex, MannKind, Mumford, Owen, and Innovata are striving to develop their own non-invasive insulin delivery systems and could still become the leading pioneers of the industry, if they produce a more suitable system - in which the concept of medical jewellery could play a part.

The new insulin delivery system invented here can be used in part to give back an element of control to the patient, making it more convenient and easier to manage insulin in a safe and discreet way in comparison to other vial and syringe alternatives. The prototypes developed within this project could potentially simplify treatment for millions of diabetics around the world, and could be the first of a new generation of medical devices that use jewellery sensor technologies as part of diabetes management.

*So why use jewellery, as opposed to any other product?* The use of jewellery in part inspires confidence and self pride in the device, carried on the body as a safeguard, rather than a hindrance. Also, craftsmanship does not typically take precedence when developing a medical device. However in this instance, the jeweller / craftsmen can approach ergonomic issues that can typically be easily overlooked by a product designer. Overall, the newly developed HGMS and IDS relies on user interaction to improve the accuracy of the dose. Data logging will record both the medicine and user interaction to endure a more discrete, reliable and simplistic system. By recording both types of data at the same time, a tighter control over the use

of the medicine can be achieved, further eliminating any unnecessary potential for human error, thereby enhancing the integrity of the treatment in a healthy and safe manner for use by people at home or by health professionals in a hospital setting.

The medical jewellery developed here could provide a cheaper and more user-friendly set of products, applying BABY-BLUE technologies to reduce the handling of the whole-blood sample when in transition from lancet to glucose meter, making the process less messy, easier to manage and highly accurate. I believe that the application of jewellery characteristics have enabled the development of a new type of pharmaceutical product that is both fully functional and aesthetically pleasing. The level of new thinking, in regards to applying qualities of jewellery to future medicinal products is innovative in pursuit of a more practical and accessible home glucose measuring system (HGMS) and insulin delivery system (IDS). In addition, the innovations developed within this research could be used in future medical devices to ameliorate many fears of administering medication in public. Diabetes cannot be controlled merely by insulin alone. The new home glucose monitoring system, insulin delivery system, and BABY-BLUE technologies combined could help the patient make better decisions about their medical needs. By doing so the patient is given the ability to take better control of their diabetes whilst maintaining a good quality of life.

## FUTURE DEVELOPMENT

A future development could be to consolidate the separate devices into one hand-held device that can perform all three functions, for ease of use. *So, how could this be possible?* The inbuilt wireless technology would receive data from any of the BABY-BLUE modules (developed in Chapters 2 and 3). The device would then record and even update the correct insulin dosage for administration. This feature would provide the user with more control and reassurance that the correct dose is being administered.

By embedding close-proximity sensors in jewellery, the insulin device will be-able to receive data wirelessly and store the recorded data to display and update the recommend dose of insulin. The user would have the control to safely change from a 'glucose mode' to the 'insulin delivery mode' by simply reloading the appropriate cartridge. The device would confirm that each function is taking place in the correct order whilst (in the background) collecting and sending data about its use. The patient would then at a later date be able to see how well the handling process and administration has been performed. This would give the user the option to learn to optimally use the device and the medicine to achieve maximum results. This patient-to-device and device-to-patient feedback would provide peace of mind and security that the device is being used properly, whilst giving the patient the control to adjust any changes to the insulin dose and suit their lifestyle.

# CHAPTER 6

**PROJECT HUMAN IMMUNODEFICIENCY  
VIRUS**  
*Design Development*

243

**UNDERSTANDING THE VARIOUS HIV  
TREATMENTS**  
*The Patient and their Physician*

244

**DEVELOPING A PILL CARRIER**  
*Storing Tablet Medication*

246

**DEVELOPING A NEW FLEXIBLE WATCH**  
*Controlling Daily Medication Requirements*

253

**SUMMARY**  
*Overview of the BABY-BLUE Cube and Watch*

261

## PROJECT HUMAN IMMUNODEFICIENCY VIRUS

- Design Development -

Human Immunodeficiency Virus (HIV) is one of the most feared diseases faced by people today, partly due to the aggressive degenerative effects it can have on the body. According to the Government Research Audit of 2005<sup>64</sup> conducted by the Health Protection Agency there are at least 63,500 people in the United Kingdom living with HIV. Such statistics show the severity of the disease and the need for better awareness to prevent further infection<sup>65</sup>. At the same time better product healthcare is required for those that are already diagnosed. This part of the research focuses on the development of a new medication carrier and BABY-BLUE watch technology. They demonstrate a new set of self-care products that can be used as an alternative way of carrying vital medication whilst reminding the wearer to take them on time. Alternately, they could be used together or apart to help patients (like those with HIV) to manage their medicines in an effort to maintain a healthy lifestyle<sup>66</sup>.

Outcomes developed here are *not* intended to provide a definitive solution for HIV patients, however, they do offer an alternative way of thinking and creative practise aimed specifically at designers of medical products or craftsmen who are working towards developing future pharmaceutical products.

---

<sup>64</sup> Statistical figures referring to the number of people with HIV in 2005. More information can found at . Invirase (2007) *Living with HIV* [online] available from:

<http://www.invirase.com/livingwithhiv/living-allabouttreatment.asp> [Accessed June 2007]

<sup>65</sup> BBC News. (2002) Medical Needles Spreading HIV [online], BBC News, available from:

<http://www.aegis.com/news/bbc/2002/BB021102.html> [Accessed 21 February 2005]

<sup>66</sup> Target the virus in an effort to reduce your viral load and increase your CD4 cell count (T cells).

## UNDERSTANDING THE VARIOUS HIV TREATMENTS

*-The Patient and their Physician-*

Human Immunodeficiency Virus on a cellular level infiltrates and enters a specific white blood cell population known as CD4+ T lymphocytes. These white blood cells are produced by the body to mediate the immune system's response to viral invaders, acting as the body's defence against infections and diseases. The problem is that the virus rapidly destroys these cells faster than the body can replace them, leaving the immune system weak and the body vulnerable to any other invading viruses.

*So, how can medical jewellery help?* The virus has the ability to mutate and change its genetic features, making it difficult to suppress. Since the 1980s combination therapy has been practised to slow down the duplication process of the virus to allow the body to produce enough CD4 cells to sustain a healthy immune system for longer. For this to be made possible a number of different medicines are used together to target the virus at different stages of its replication cycle. This is where medical jewellery can help carry, support, and protect four combination medicines, known as fusion inhibitors, nucleoside reverse transcriptase inhibitors, non-nucleoside reverse transcriptase inhibitors and protease inhibitors.

In the best interests of this research, I detailed some of the key considerations before developing a new medication carrier and BABY-BLUE watch technology.

- The jewellery should not come into conflict with the physician's treatment.
- The two technologies should not cause discomfort to the patient when worn on or close to the body.
- The use of jewellery as opposed to any other product is intended to confidently ensure the patient that the monitoring of their medical parameters can be discreetly integrated into the lifestyle of all patients living with HIV or AIDS aged between 15 and 59. (This being the largest demographic range).
- All inventions should hold up to the expectations of both the patient and physician.

Using jewellery to monitor, record and even assist in the delivery of medicines is the objective. It will be paramount to provide better healthcare in regards to accessibility, comfort and practicality when in use on a daily basis. The design of the jewellery needs to consider the various aspects of daily life. The body adornments may be of more value when consistent monitoring of medicinal parameters is required. Medical jewellery could be used as an analysis tool, worn as a discreet and comfortable alternative for a set duration of time. This leaves the patient to go about their daily activities. Their results could be obtained by the physician via BABY-BLUE technologies.

## DEVELOPING A PILL CARRIER

- Storing Tablet Medication -

Even the most determined patients with good intentions can find themselves deviating from a tight controlled treatment regime<sup>67</sup>, partly due to there being limited product support. If a new medication carrier was developed to be worn on or close to the body, this would make the medication more accessible in times of need and greatly decrease the risk of the patient forgetting to take them. Most HIV patients are typically given pill boxes or trays by pharmaceutical stores. They are basic, inexpensive, durable and provisionally adequate. On a practical level, they are cumbersome to carry, unpleasant to look at, and are designed for home use. I believe that the pill-box design is effective in keeping medication fresh, but impractical and inappropriate for use in many other real life situations.



**Fig. 133**

White Pill Box with Medication  
2008

Seven compartments with air-tight seals

Photograph taken from online source:  
[www.blogs.dogster.com](http://www.blogs.dogster.com)

---

<sup>67</sup> Difficulties of following drug resistances "What It Is, How It Develops, and What You Can Do to Prevent It," the pull out and save section of the June 1998 issue of *AIDS Care*.



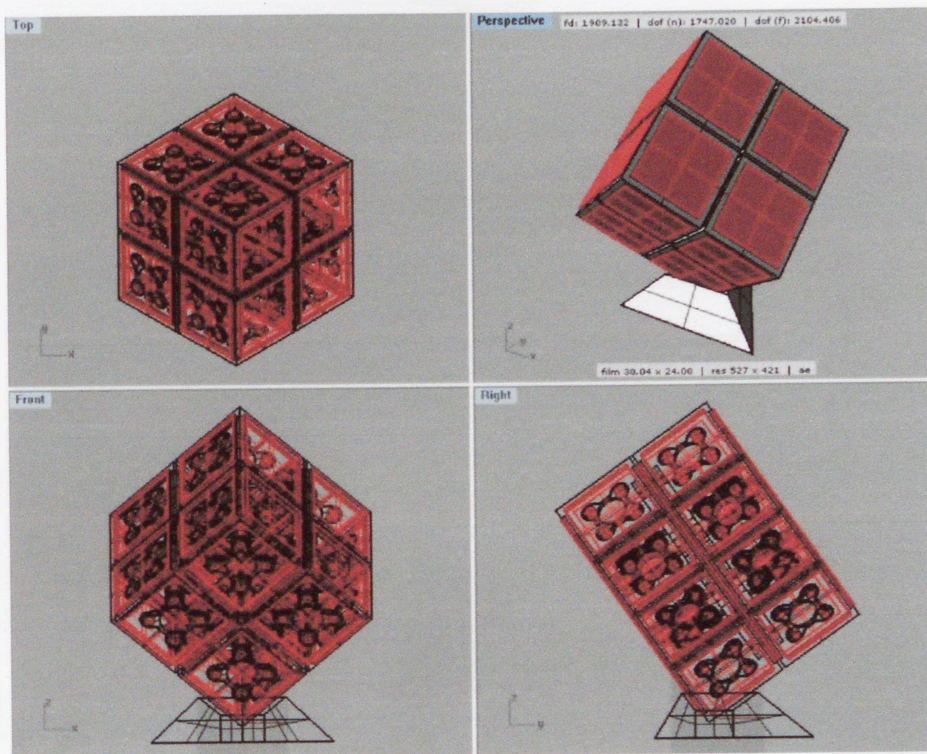

**Fig. 134**  
Anti-Viral Medication  
2008

Photograph taken from online source:  
[http://blogs.poz.com/mark/upload/Dinner\\_Pills.jpg](http://blogs.poz.com/mark/upload/Dinner_Pills.jpg)

There are some people who find the idea of using a pill-box in social situations to be a sign of weakness, signifying health issues, which could be seen as embarrassing or an invasion of privacy. The judgement of others can become so overwhelming that the patient could feel others might perceive them in a different mindset or present negative stigma. Medical jewellery could ameliorate negative perceptions, as elements of desirability could bring a unique dual functionality. The action of taking the medicine would be less intrusive. If the wearer feels good and less embarrassed then positive interaction in maintaining tight control of their drug regime will continue, irrespective of the place, time or situation, to ensure the medication is used as prescribed.

The patient is likely to need a device that can hold and support different medication types. This means that the jewellery or device needs to accommodate a variety of pills sizes. Figs. 135-137 illustrates a new medication carrier and stand. The intention here was to introduce an element of playfulness. Each cube was designed to be removed or stacked to form an array of ornamental forms and intended to be carried on the body. This was at a later stage achieved by integrating a magnetic pendant, shaped like a pyramid and at the same time be used as a stand.



**Fig. 135**

Top, Front, Right and Perspective View of the First Generation  
BABY-BLUE Cube design.

3-Dimensional Design, built in the software packages Solidworks  
and Rhino 3D

2008

© Leon B M Williams

Centre for Jewellery Research,  
Royal College of Art, London

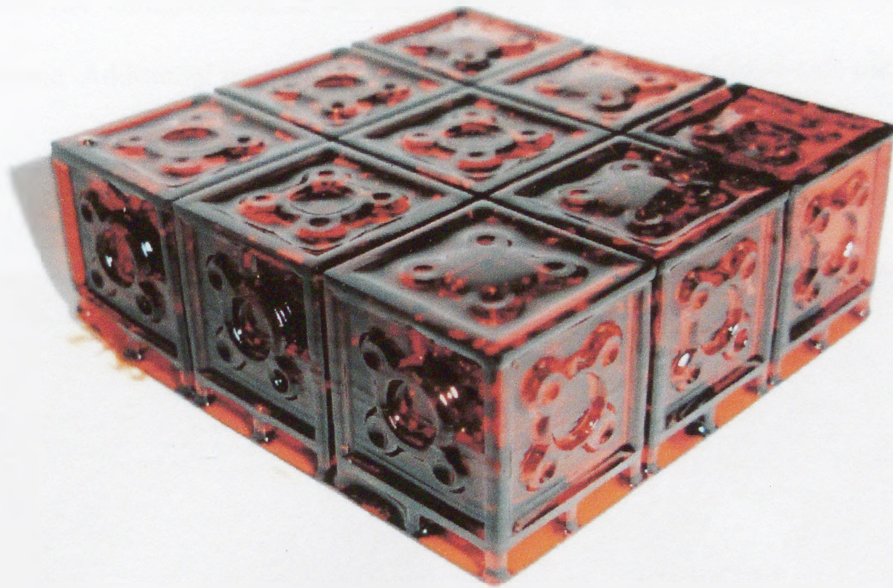

**Fig. 136**

Set of Rapid Prototyped BABY-BLUE Cubes  
in Resin (Envision Technology)

H:30 x W:30 x D:10 mm

2008

© Leon B M Williams

Centre for Jewellery Research,  
Royal College of Art, London

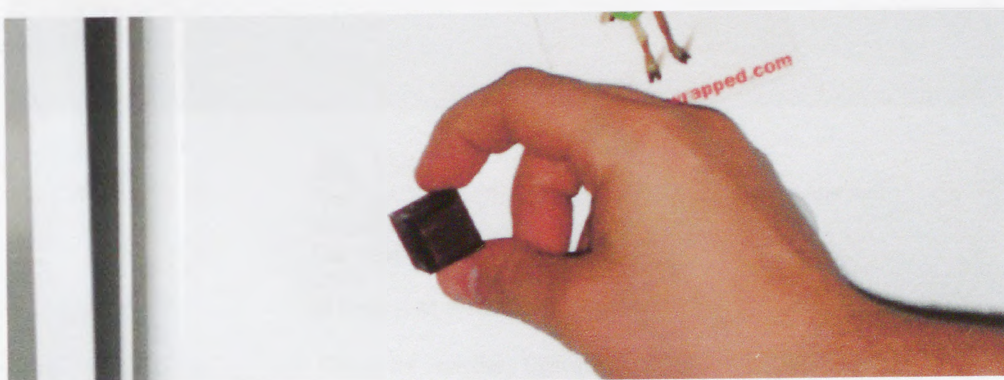

**Fig. 137**

BABY-BLUE Cubes with Integrated Disk  
Magnets Fixed to Refrigerator Door

2008

© Leon B M Williams

Centre for Jewellery Research,  
Royal College of Art, London

From a design perspective the practicality of the jewellery should not be short-lived nor compromised if the patient needs to convert or change their drug regime. Additional improvements applied various coloured food-safe plastics.

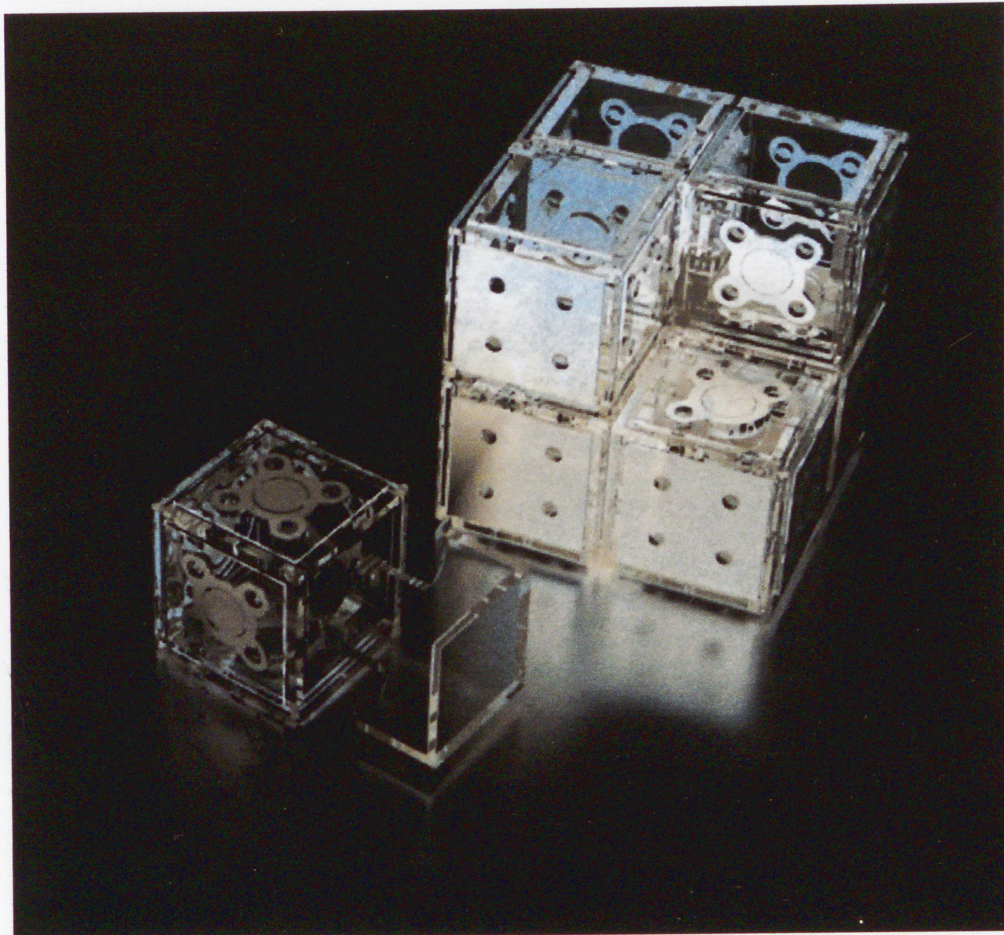

**Fig. 138**

Final BABY-BLUE Cube Concept Design with Integrated Magnets.

Clear plastic, silver panels

2008

© Leon B M Williams

Centre for Jewellery Research,  
Royal College of Art, London



**Fig. 139**  
32 inch Silver Chain with Detachable Magnetic Pill Boxes  
2008  
© Leon B M Williams

Centre for Jewellery Research,  
Royal College of Art, London

Fig. 139 shows a plastic and silver BABY-BLUE CUBE. Its cubic form brings a practical and pleasurable element to the provisional storage of tablet medication, when carried on the body. The new design features rare earth magnets mounted in three of its six face structures. This gives the ability to stack and arrange multiple cubes, so that the cubes can be used independently as jewellery or collectively as an ornament or centre-piece in the home or workplace. Additional protective covers can be fitted to each face on a single cube. This hides the medication when carried in public, giving the patient more freedom to use a more discreet and user-friendly product.

## DEVELOPING A NEW FLEXIBLE WATCH

- Controlling Daily Medication Requirements -

Science tell us that HIV can affect vital organs such as the brain, hindering its ability to function properly - in particular, the hippocampus, which is a small structure located deep in the brain and is largely responsible for processing short-term information. Also, the cerebral cortex which covers the outer layers of the brain and stores long-term memory can be affected. As the virus load increases it can cause the patient to experience memory loss, thus making it difficult to concentrate on daily tasks such as remembering to take medicines. One method of regulating medicines is to use a two clock face technique<sup>68</sup> (as shown in Fig. 140).

**Fig. 140 (Next Page) >>**

Combination Antiretroviral Medicine Routine for  
Patients Living with HIV based on Helen M.  
Miramontes Clock Face System  
2008  
© Leon B M Williams

Centre for Jewellery Research,  
Royal College of Art, London

---

<sup>68</sup> Examples can be found online. Mastering Combination Therapy, (April 1997) *The Body'-The complete HIV/AIDS Resource, San Francisco: General Hospital* [online] available from: <http://www.thebody.com/content/treat/art12715.html> [Accessed July 2007]

WITH BREAKFAST

Adefovir: 60mg - 1x500-mg carnitine supplement should be taken with each dose.  
 Nevirapine: 1x200-mg tablet if on twice-a-day dosing; 2 200-mg tablets if on once-a-day dosing

Delavirdine: 4x100-mg tablets

AZT: 1x300-mg tablet

3TC: 1x150-mg tablet  
 Combivir: 1 tablet (300 mg AZT/250 mg 3TC)

ddC: 1x0.75-mg tablet - ddC (zalcitabine, Hivid®) should not be used concomitantly with ddI or taken simultaneously with antacids.

d4T: 1x40-mg capsule or 1 30-mg capsule, as assigned by physician based on patient's weight

Hydroxyurea: 1x500-mg tablet

Abacavir: 1x300-mg tablet

Ritonavir: 6x100-mg capsules (or 4 100-mg capsules if taken with saquinavir) - o Ritonavir (Norvir®) should be kept refrigerated and should be taken with a meal or snack that contains fat, to promote absorption of this drug. o All references to saquinavir are to the soft-gel capsule formulation of this protease inhibitor, which goes by the trade name of Fortovase®.

Saquinavir: 9x200-mg capsules if on twice-a-day dosing; 6 200-mg capsules if on three-times-a-day dosing; or 2 200-mg capsules if taking with ritonavir - (6) Almost all protease inhibitor combinations are taken twice a day. When the combination includes Indinavir (Crixivan®), doses should not be taken with food. If you must eat during the hour before you take one of your doses of indinavir -- or within two hours after you take a dose -- confine yourself to no-fat or low-fat snacks. (Your primary-care provider can give you a list of approved snacks.) People with HIV who take indinavir as part of their combination antiretroviral regimen should drink at least 1.5 liters of extra liquid daily.

Viracept: 5x250-mg tablets  
 Amprenavir: 8x150-mg capsules

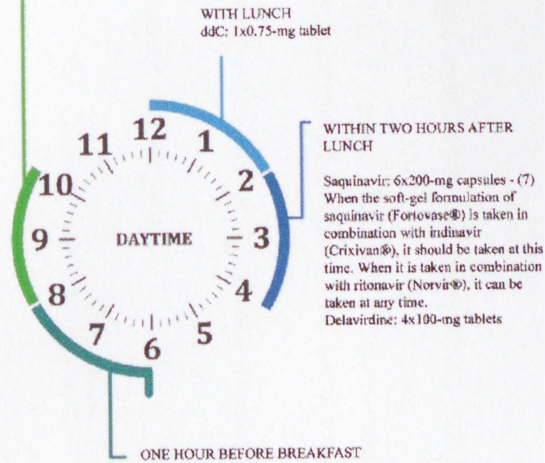

WITH LUNCH  
 ddC: 1x0.75-mg tablet

WITHIN TWO HOURS AFTER LUNCH

Saquinavir: 6x200-mg capsules - (7) When the soft-gel formulation of saquinavir (Fortovase®) is taken in combination with indinavir (Crixivan®), it should be taken at this time. When it is taken in combination with ritonavir (Norvir®), it can be taken at any time.  
 Delavirdine: 4x100-mg tablets

ONE HOUR BEFORE BREAKFAST

Indinavir: 2x400-mg capsules should be taken on an empty stomach, preferably one hour before a meal. It is highly recommended that the patient drinks 2-3 glasses of water within two hours of taking each dose of this drug including an extra 1.5 liters of fluid throughout the day.

BEFORE BED

Indinavir: 2 400-mg capsules with at least 2 full glasses of water in the first 2 hours after ingestion.

Efavirenz: 3 200-mg tablets - Efavirenz (Sustiva®) should not be taken with a high-fat bedtime snack, as fatty foods increase the side effects of this drug (which include sleep disturbances and mild disorientation).

DdI: 1 150-mg and 1 100-mg tablet (total:250-mg) or 2 150-mg tablets and 1 100-mg tablet (total:400-mg). Depending on patient's weight, - ddI (didanosine, Videx®) must be taken on an empty stomach - two hours after and one hour before the next meal. Alcohol may increase the toxicity of this drug.

\*Standard maintenance doses for adults before adjustments for potential drug-drug interactions

WITH DINNER

Saquinavir: 6 200-mg capsules  
 Delavirdine: 4 100-mg tablets

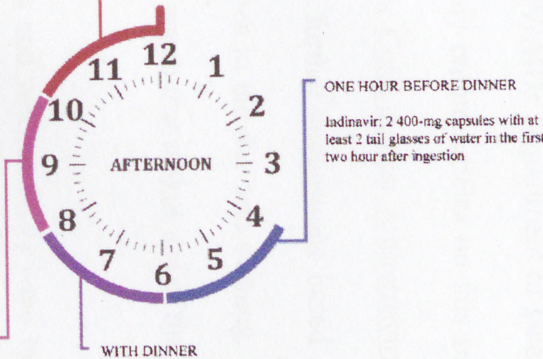

ONE HOUR BEFORE DINNER

Indinavir: 2 400-mg capsules with at least 2 full glasses of water in the first two hour after ingestion

WITH DINNER

Nevirapine: 1 200-mg tablet if on twice-a-day dosing; 2 200-mg tablets if you are on one-a-day dose and did not take your dose in the morning

AZT: 1 300-mg tablet  
 3TC: 1 150-mg tablet  
 Combivir: 1 tablet  
 ddC: 1 0.75-mg tablet  
 d4T: 1 30-mg or 40-mg capsule  
 Hydroxyurea: 1 500-mg tablet  
 Abacavir: 1 300-mg tablet  
 Ritonavir: 6 100-mg capsules (or 4 100-mg capsules if taken with saquinavir)  
 Saquinavir: 9 200-mg capsules if on twice a-day dosing; or 6 200-mg if on three-times-a-day dosing; or 2 200-mg capsules if taking with ritonavir  
 Viracept: 5 250-mg tablets  
 Amprenavir: 8 150-mg capsules



Helen M. Miramontes<sup>69</sup>, M.S.N., R.N. M, a member of the President's Advisory Council on HIV/AIDs Department of Health and Human Services, USA, has published many online articles on this subject including the two-faced clock technique in Combination Antiretroviral Therapy in August of 1999. The article gives further suggestions based on patient experience in taking anti-HIV medicines in the day and evening. The main challenge here was to develop a digital watch that makes use of the two-face system.

Many participants (with and without HIV) were in agreement that a newly developed digital-time-piece with easily programmed functionality could be highly beneficial as a memory aide.

The key guidelines were:

- To help and assist a patient undertaking anti-HIV drug therapy.
- To develop a device that could accommodate the needs of a wide demographic audience with different medicinal needs.
- To act as a medical aid and personal item of jewellery.
- To be discreet and elegant.

---

<sup>69</sup> Helen M. Miramontes, M.S.N., R.N., is Deputy Director at The International Center for HIV/AIDS Research and Clinical Training in Nursing and a member of the President's AIDS Advisory Council. Miramontes, H. M. M.S.N., R.N. (1999) *Practice Makes Perfect A Safe, Simple and Sensible Way to Accustom Yourself to the Dosing Demands of Combination Antiretroviral Therapy* [online] <http://www.thebody.com/content/art12700.html> [Accessed 12 Nov 2007]



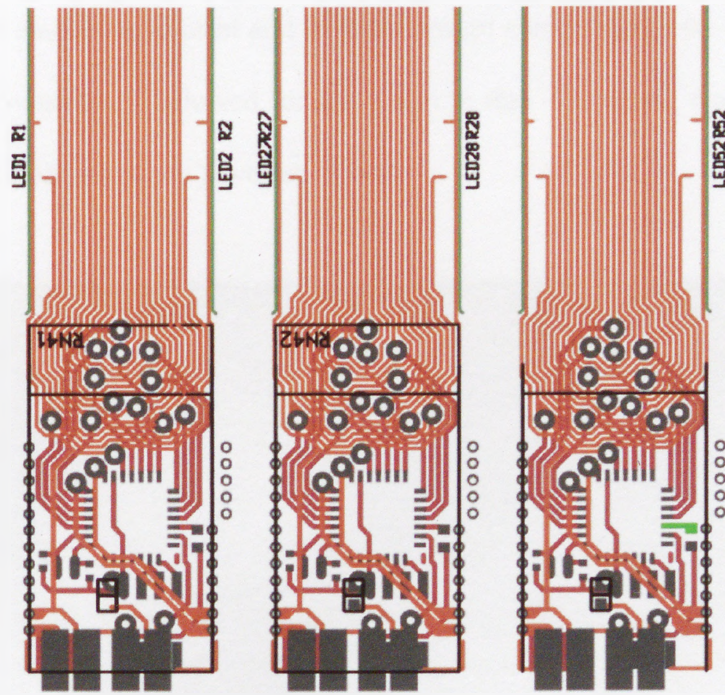

**Fig. 142**  
 BABY-BLUE Watch Layout Patterns  
 Multi-layered design for flexible substrate.  
 2008  
 © Leon B M Williams

Centre for Jewellery Research,  
 Royal College of Art, London

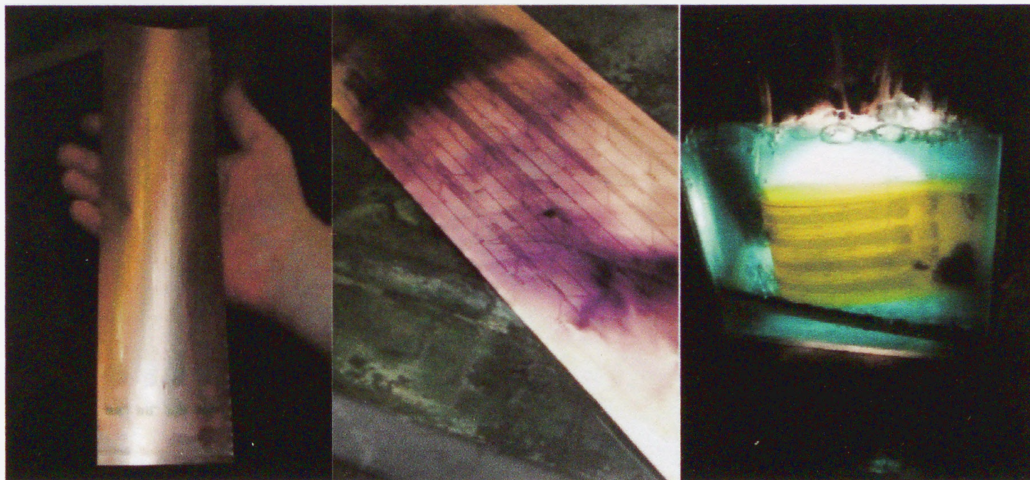

**Fig. 143**  
 Photographic Sequence Showing the Print and Etch  
 Process for Fabricating a Flexible BABY-BLUE  
 Watch Circuit Board  
 2008  
 © Leon B M Williams

Centre for Jewellery Research,  
 Royal College of Art, London

The next stage was to print and etch the design configuration on a 0.4 mm flexible substrate. It allowed for the watch to flex – meaning that it could be integrated into many jewellery forms.



**Fig. 144**  
Testing the New Circuit Pattern  
Configuration using Process known as  
‘A-bed-of Nails ‘  
2008  
© Leon B M Williams

Centre for Jewellery Research,  
Royal College of Art, London

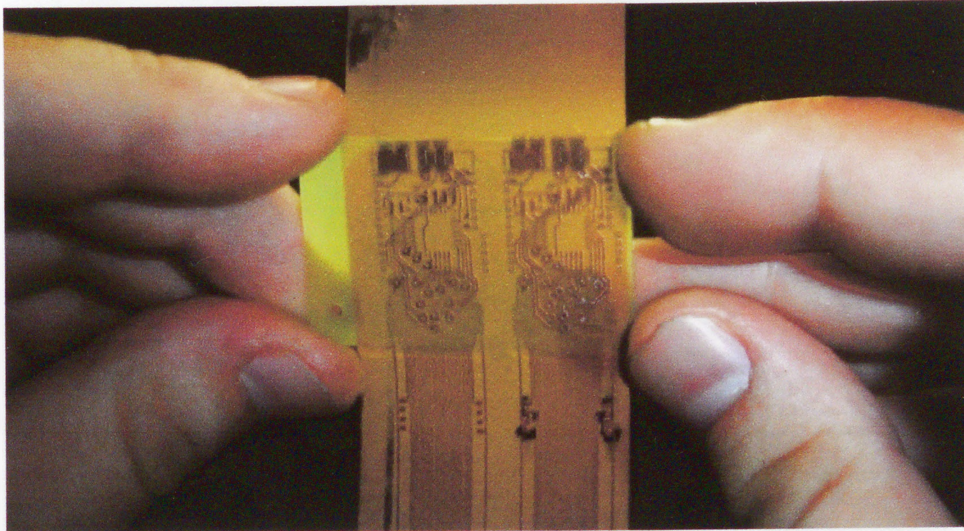

**Fig. 145**

Soldering the Components Together  
to Form the Basis of the BABY-  
BLUE Watch.

2008

© Leon B M Williams

Centre for Jewellery Research,  
Royal College of Art, London

The problem is that most digital watches developed today for non-medical use can be too complex in programming or may not have enough flexibility in alerting the wearer several times a day. It is vital that all anti-HIV medicines are used as prescribed by the physician or specialist. If the patient deviates from the treatment plans, this may cause the body to build a resistance to the medicines which are keeping their body's immune system stable. If the patient repeatedly forgets to take the medicines as prescribed this will reduce the effects of the medicines and cause the viral load to rapidly increase. To overcome this problem a new BABY-BLUE watch has been pre-programmed to glow and pulse, indicating an active state and also acting as a subtle reminder of the many responsibilities involved in maintaining a healthy lifestyle and keeping to the agreed treatment plan. The BABY-BLUE watch served as a reminder to take various prescribed

medication throughout the day. It was designed to be easily programmed in conjunction with the healthcare professional.

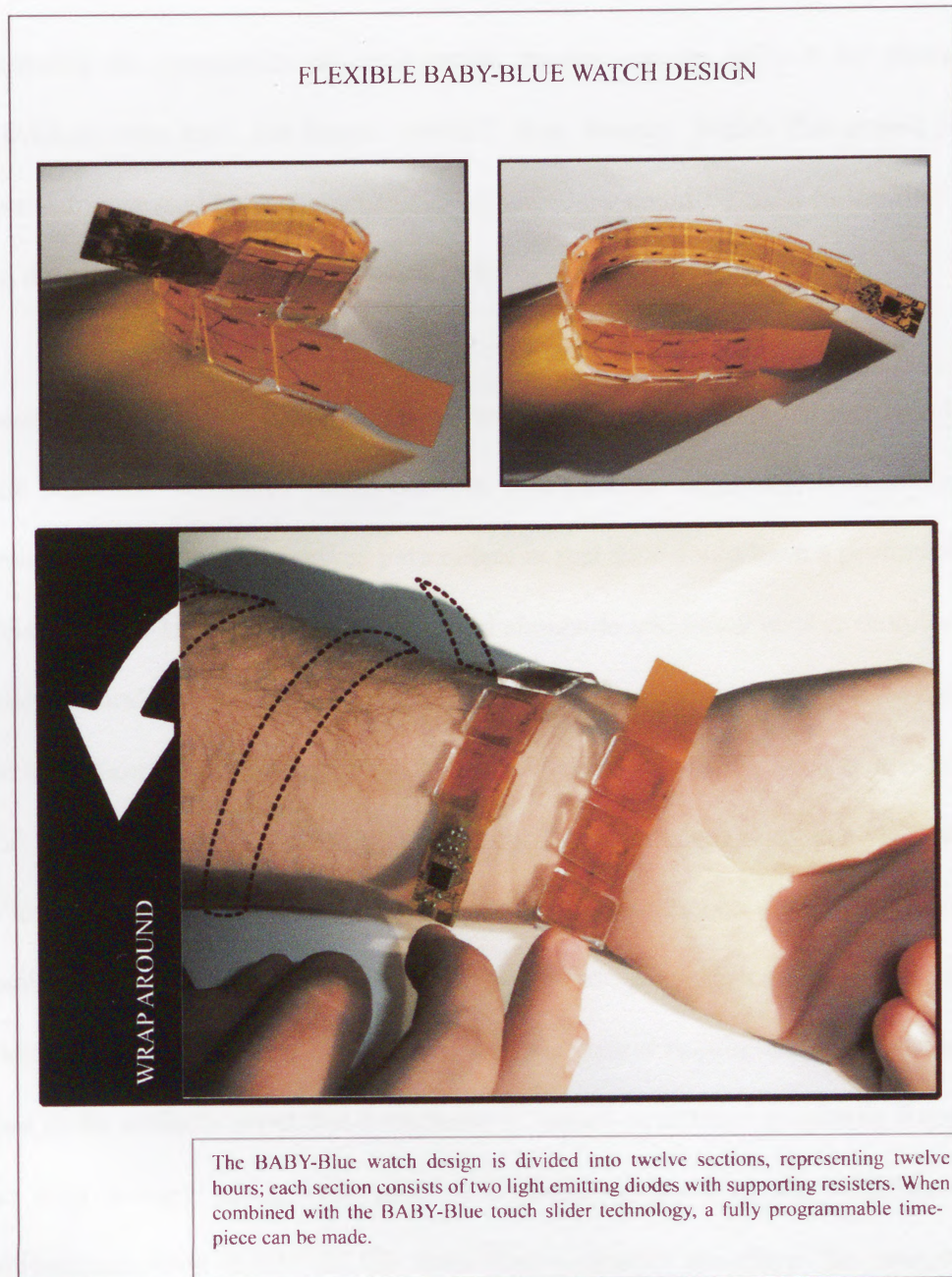

**Fig. 146**

Trial Testing the BABY-BLUE Watch.

2008

© Leon B M Williams

Centre for Jewellery Research,  
Royal College of Art, London

## SUMMARY

*- Overview of the BABY-BLUE Cube and Watch -*

Mastering the complexity of combination therapy can be difficult for those individuals who have just begun anti-HIV drug therapy. Within this project I have demonstrated how characteristics of jewellery could be used to improve and develop a new form of medical jewellery.

Future improvements could include a new BABY-BLUE pocket-pal that could send electronic messages (RSS) between two patients. Arguably, a wearable device that can monitor medical parameters in real time could have a profound impact on anti-HIV treatment and be used alongside additional tests to monitor patient's viral status. For the patient, it is vital to alleviate the condition and at the same time would be beneficial to take pleasure in wearing such a device. This would encourage patients to learn about the experiences of others who are following similar antiretroviral treatment plans. This function of assisting one another via their jewellery could bring together a wider community. In addition the jewellery could be used to help the wearer re-programme the daily dose in the unlikely event that a medicine is missed or omitted accidentally from the drug therapy plans, with additional advice given from the healthcare professional. With BABY-BLUE technologies-sensory jewellery, the patient could manage their disease with accuracy and maintain control, which could be a future development direction for medical jewellery.

# CONCLUSION

## EVALUATION PHASES

*The Case for Developing Jewellery for Disabilities for Better Patient Care*

263

## RESEARCH METHODOLOGY REVIEW

*Reflection upon the Research Methodology*

266

## FINAL PROJECT REVIEW

*Critical review of the Three Case Studies*

267

## CONSULTATIONS

*Interviews, Questionnaires and Meetings*

271

## CRITICAL REFLECTION

*Research Review*

273

## COLLABORATIVE RESEARCH THINKING

*Craftman and the Scientist*

275



**Fig. 147**

Focus Group

Discussing the value and purpose of medical jewellery  
2008

© Leon B M Williams

Centre for Jewellery Research,  
Royal College of Art, London



## EVALUATION PHASES

*-The Case for Developing Jewellery for Disabilities for Better Patient Care -*

Facilitating a clear and definitive idea of what medical jewellery is, and its usefulness in comparison to other medical self-care devices, is vital. Experts like Dr Vallance-Owen (2003)<sup>70</sup> states: *“There is a lot of talk about the patient as a consumer, but there has been little research on patient involvement in health care”*. It is imperative that new innovations from all fields of research are considered. I believe that the evidence and new developments shown in this research demonstrate a strong case for putting medical jewellery into practice and for the industry as a whole to integrate characteristics of jewellery into its products: e.g. implement a design that is more compact, discreet, and easy to carry; to improve the products’ hold/grip design features for people with disabilities; and also implement precious materials for better hygiene, whilst amplifying the products desirable and practical appeal.

Organisations such as the British United Providence Association (BUPA), the Disabled Learning Foundation (DLF), and the Road Safety Audit Design Direction (RSA-DD), are working to improve this situation, with The Disability Discrimination Act 2005 and other government policies acting as a catalyst for ‘change’. They are pioneers in regenerating and re-inventing medical products for people with disabilities, although they are not applying

---

<sup>70</sup> BUPA: Promoting care, medical solutions and healthy communities, (2003) [online] [http://bupafoundation.com/asp/about/latest\\_news\\_articles/asthma.asp](http://bupafoundation.com/asp/about/latest_news_articles/asthma.asp) [Accessed October 2004]

the principles of jewellery within their designs, which is where my particular area of research lies. Medical jewellery draws from the fields of craft and science to help develop and improve the application of medicine for patients, and at the same time improve the patient's quality of life. "*Around 600 million prescription items are processed each year by the NHS's Prescription Pricing Authority (PPA), the total value of prescriptions accounting for £6.6 billion a year- approximately 13% of the total NHS costs*"<sup>71</sup>. These figures highlight and contextualise the colossal scale of the issues and problems that relate to the dispensing of prescriptive medications and assistive products.

This research has shown that there would be a strong demand for items that could hold and administer prescriptive medication in a method more compatible with the patient and their lifestyle. If Dr Vallance-Owen is correct in his statement, this then correlates that a high proportion of the £6.6 billion per year (recorded in 2004) spent on prescriptions could be partly reduced by the introduction and widespread use of medical jewellery, as the patient would be encouraged to take better care of their medical device. This highlights a need or improvements, of which medical jewellery could be part of the solution. In the long-term this would improve patient care and medication delivery, whilst potentially reducing costs in relation to medical assistive products.

---

<sup>71</sup> RSA: Design Direction, (2004) *Design for Patient Safety*, Exploring a role for design in a key area of patient safety [online] <http://rsa-design.net/directions/2004-05/designforpatientsafety.htm> [Accessed 08 October 2004]

Rarely, if ever, does design for a mass-product become a 'craft' product. Perhaps this is because the jeweller's craftsmanship can be difficult to learn and master as many of the making processes require great skill, effort and practice. It is important to note that engineers have their own complex making processes, but I believe that if both making approaches and techniques were considered by product developers then a more fully resolved outcome could be realised. Outcomes could be developed for mass production or as a bespoke one off piece. All the invention developed as part of this research function as fully working medicinal products in their own right. They also have many jewellery/adorn-able qualities which make them easy to manage and deliver medication. The central premise for this research was *not* about the development of attractive packaging for different medicines. However, it does demonstrate how symbolic, sensory, and personalisation qualities could successfully be considered at all stages of product development to improve the patient's experience of carrying and administering their medicine in an effective and safe way. In fact, I believe that, medical products with jewellery characteristics could reduce many emotional obstacles or social stigma associated with living with asthma, diabetes or HIV.

## RESEARCH METHODOLOGY REVIEW

*-Reflection upon the Research Methodology-*

This research has led to the successful development of BABY-BLUE technologies, demonstrating how jewellery can be used to monitor a patient's medical condition. The medicinal and commercial benefits have proved to be valuable not only as jewellery, but also as portable devices to give the wearer more self-confidence. Medical jewellery has been developed to suit both practical needs and maintain a good quality of life.

On a technical level, rapid forming technologies, applied alongside newly invented conductive wire processes, have made it possible to push the boundaries of digital jewellery for future use by craftsmen. The key element of the research has been to develop conductive imagery through and on the surface of jewellery to give the objects interactive qualities. The research demonstrates how close-proximity sensors can improve the management of diabetes and also the potential to use jewellery in a similar manner to improve a wide range of other medical applications, from asthma, respiratory care and stress related conditions to general health care.

## **FINAL PROJECT REVIEW**

*-Critical review of the Three Case Studies-*

Project Asthma clearly demonstrates the value of medical jewellery working as a user-friendly and even child-friendly aerosol device to preserve steroid and Beta-2 agonist medicines and improve their delivery, efficiency, and effectiveness. Project Diabetes, being the most in-depth of the three case studies, has shown that insulin medications and needles can be carried without fear or social stigma when characteristics of jewellery are integrated into the design with the development of future HGMS and IDS devices. Furthermore, the research has shown how jewellery can be used to control medication for HIV patients, alleviating for the patient many of their worries about human error, and giving the reassurance of knowing the medication is available as required. In essence, medical jewellery has proven to provide a balance between practical use in the delivery of medicines and a piece of jewellery which is pleasurable to carry on or close to the body even in times of emergency.

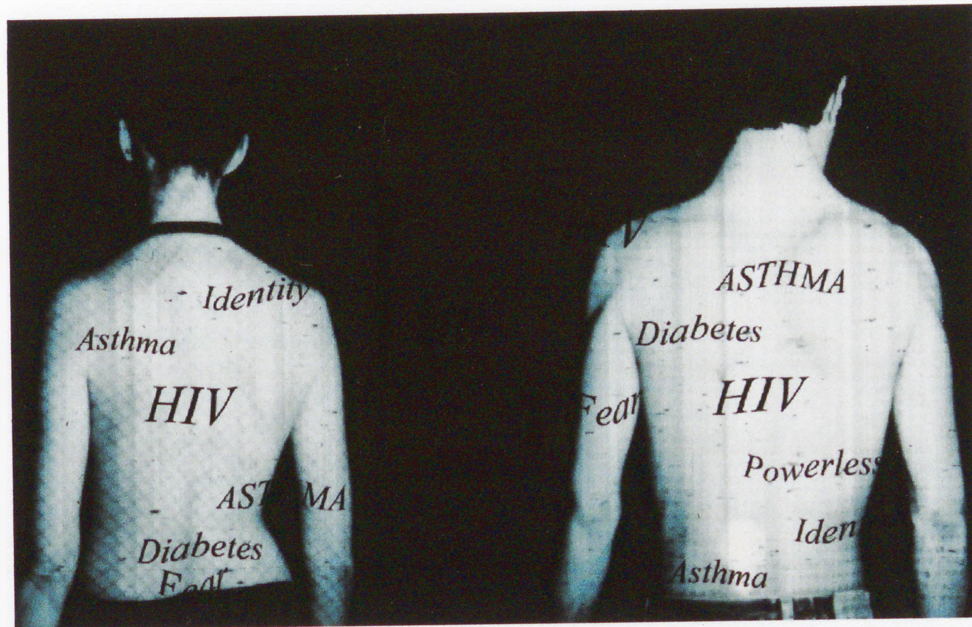

**Fig. 148**  
Dealing with Social Phobias  
Black and White Photography  
England  
1997  
© Leon B M Williams

University of Coventry

The focus of medical jewellery developed in these projects has involved extracting information through product trials, to cast critical perspective views on the items that could potentially be future aids. This has been a vital source of information to ensure that medical jewellery is suitable for its market, whilst reflecting on the possibility of change for improvements. The involvement of future consumers in all aspects of the design development has encouraged a healthy balance of opinion. The assessment of information from consumer participation in product trials has cast a critical perspective on other items that could potentially be developed as future aids. All this collated information ensures that medical jewellery will be current and suitable for its market. Although the technologies developed here have been primarily designed for the three projects, they can be adapted for other medical conditions, (other uses) or even non-medical purposes (to improve touch sensitive technologies). This is made possible as all the accompanied

footprints, schematic diagrams, and computer coding algorithms can be quickly sourced with clear guidance for other uses, even with little knowledge of any of the technical instructions or programmes.

A number of artists and jewellers utilise medicine as the focus of their work, yet there has been little research in the field of medicine which refers to jewellery as a medical aid. For me, good design practice is not simply a matter of aesthetic. It is about establishing an appropriate mix of skills to best demonstrate intelligent thinking in pursuit of resolving real life problems as elegantly and effectively as possible. Arguably, medical product engineers do not apply the complex jewellery making techniques. This research has focussed on bridging the division between the disciplines of medicine and jewellery. This was achieved by incorporating the transferable characteristics of jewellery to refine, change or rectify the design of medical products. Increasing the quality of life for the consumer has been a high priority, whilst reflecting on the possibility of the ongoing progression of medical jewellery.

In truth, we are shaped by the very things that surround us - amongst which jewellery in its history has been used as an amulet for fertility by women, for virility by men, and to protect vulnerable children, helping to overcome illness. Even the ancient Egyptians and Graeco-Romans, who first developed scientific medicine, added the element of magic. It was always believed that wearing magical jewellery drew upon godly powers to ward off evil and protect against medical illness. Looking back on its history, jewellery has always played a role in medicine.

This research also focused on developing 'the device of today' as well as 'the device of the future'. Through my case studies, user groups, discussions with medical professionals and private research, it has become clear that a number of medicines are not being used by patients properly, or to their optimum. A potential problem associated with medical jewellery could be its abuse by people using it for a non-medical purpose. Monitoring the use of the devices would need to be carried out, and managed. However, as demonstrated in the previous projects, the participants have agreed the potential benefits would far outweigh any limited misuse by a minority of people. If I was to take this research further, the next logical phase for the development and implementation of medical jewellery would be to move beyond the design, user group and development stage and proceed to medical testing.



## CONSULTATIONS

- Interviews, Questionnaires and Meetings -

All patients that took part in this research spoke frankly about the lack of medical healthcare in respect to the products dispensed on the National Health Service. In fact, the general consensus was shared that medical jewellery products could, on an emotional and practical level help patients of all ages carry and keep fresh more medicines, for longer. One of the most interesting questionnaire responses, undertaken as part of this research came from Nurse H Hunter from Leith Mount Surgery, Scotland, 2001. She stated: *"If the patient is happy with the device they are likely to comply with its usage"*.<sup>72</sup> Critical discussions and user focus groups have also added to the research and assisted in producing products that meet the practical needs of consumers.

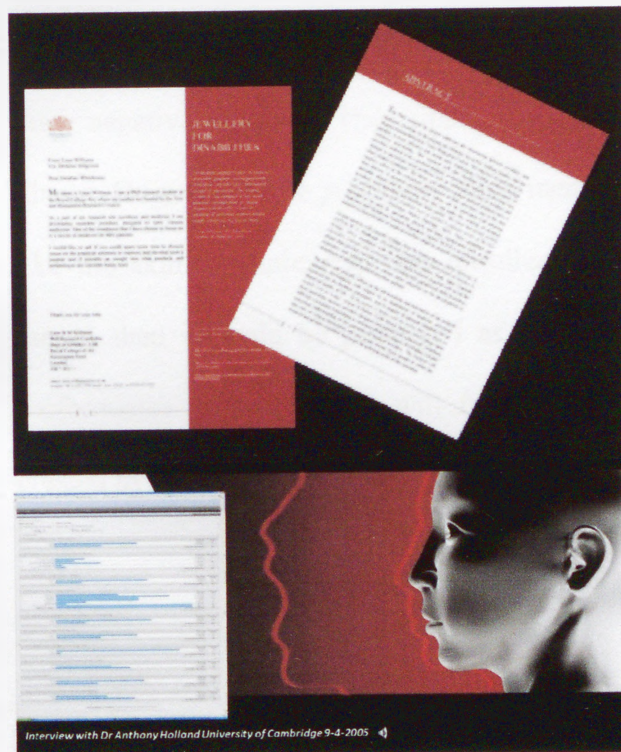

**Fig: 149**

Powerpoint Snapshot Detailing Letters and Patient Questionnaire Results. 2005-2007

Talk conducted at the Royal College of Art, London.

<sup>72</sup> Interview and questionnaire conducted by Leon. B. M. Williams – 2003

In 2005 I invited several interviews with doctors from Guy Hospital, London, specialists from Glasgow Medical School and medical experts from the Disability Learning Foundation, London. They were all asked to take part in a ‘think tank’ multidisciplinary session, discussing how medical-identification jewellery used by their patients could be improved. Psychiatrist and Lecturer Dr. Tony Holland, from the University of Cambridge was amongst this selection of interviewees. He agreed that: “...*In a way people generally don’t want to draw attention to any chronic illness or disability they might have.*” He further commented on the benefits and drawbacks of using medic alert jewellery. “... *on one level you want it to be seen because if there is a crisis you want people to notice it, but on another level there is a problem that it tells people you have a chronic or serious problem, and it seems to me that this might create a potential uncomfortable feeling.*” I believe that most medical identification jewellery sold today draw negative attention. They imply that the wearer has a serious chronic illness. However, if the jewellery could measure different body parameters, like the skin galvanic response jewellery (invented in chapter 3 of this thesis) then it could be promoted as health-care jewellery or as a sport performance product. This will further divert the negative associations, created by many current medical identification jewellery types.

## CRITICAL REFLECTION

- Research Review -

This research contributes knowledge to the field of medicine and jewellery. It also shows how some of the most important decisions were made in the development of new technologies. This work has been motivated by my enthusiasm as a maker / researcher and supported by practitioners from the fields of both medicine and craft.

*So, what went well?* All working prototypes from the asthma, diabetes, and HIV projects produced outcomes ready for manufacture. The medical jewellery proved to be more comfortable to wear and practical to use than existing products. To summarise, the research is unique in its approach of using jewellery forms, techniques, and applications' as a means of making self-care medical products safer and more user-friendly.

*What could be improved?* Collecting data from a wide demographic of people with HIV was difficult. Assuring people that personal information would be used anonymously was challenging. Some participants felt uneasy talking frankly about their condition in person. This was overcome by conducting interviews via less intrusive means, such as telephone or webmail interviews. On reflection, more training in confidential qualitative research from a medical perspective could, in part, help me develop a stronger bond with a patient to acquire their medical history.

*What advancements could be made on the subject of medical jewellery?*

Many of the issues relating to design problems were overcome as I made adequate time allowances for all stages to be completed. I hope that this research will encourage creative people to consider medical jewellery as a milestone in the evolution of new self-care monitoring and medicine delivery systems. This research has the potential to change this area of the pharmaceutical product industry. With further financial or industrial backing, this research could be fully realised in marketable products. These will provide better access to medicines and give patients the confidence to wear them without fear.

Looking to the future and taking this research forward, I would like to involve the Trade Association for the British Pharmaceutical Industry TABPI in further collaborations. In 2006 Dr Richard Tyler (Medical Director) extended an offer to review the thesis on completion, commenting that: *“designing products is something that we are interested in... we have a group called the Involved Group Incentive Task Force which is about the provision of information for patients...”* To clarify, this research promotes good multidisciplinary / trans-disciplinary design practices through group collaborations that include the medical developer and jewellery maker. I also championed the active participation of several disciplines, such as university, industry, and government in pursuit of developing a safe outcome that is economically cost efficient to manufacture.

## COLLABORATIVE RESEARCH THINKING

- *Craftman and the Scientist* -

It is strange to think that there is still a wide language barrier between the scientist and the craftsman. *How can the practices of designing medical products and the fine craft of jewellery making be brought to work together in order to create a mutually dependent and collaborative form of research practice?* One could argue that there are many interesting debates to be had here, which are at the moment beyond the remit of this research. It is only when different specialists come together and converse in a '*think tank*' situation when fusions of creative ideas are formed. However, there have been noticeable differences in language between specialists that took part in many of the group discussions. For example, I noticed on many occasions that the term 'multidisciplinary design' used by academics from Art and Design Schools of teaching to describe collaborative projects between university, government and industry. In fact, from my experience the scientific community (including academics) favour 'trans-disciplinary' as an alternative term. This might not seem like a problem, but it can cause differences in communicating creative ideas. On reflection, I believe that a universal language is important to the future of collaborative projects, especially when the strength of a multidisciplinary design approach, promotes creative thinking and innovation through collaboration from people that come from different professional fields of research.

This research involved seven specialists, thirteen doctors, fifteen patients and more than one hundred and twenty volunteers. Their views and opinions had, in part, helped shape and support the practical, theoretical and critical aspects of this research. Looking back, I feel that my methodology was appropriately suited to write this thesis. The most challenging part was to see volunteers critically assess and even destroy working prototypes for the greater good of the design which has also opened up many interesting avenues and further research discussion.

As a researcher, I have been inspired by the possibilities that reside in the unexplored intersections of jewellery and medicines. These have become more apparent with the ever-growing need to improve many aspects of invasive medical products that are available today. Tackling sensitive issues associated with their use has been my objective, with the aim of monitoring the progression of a short-term condition or long-term disability. The practical elements of this research are reinforced by the deployment of digital technology for use in future jewellery applications. The strength of this research lies in identifying successful strategies for the deployment of jewellery within the delivery of medical assistance and in the development of products which provide practical solutions to real-world needs.