

The Seaboard:
*discreteness and continuity in
musical interface design*

Roland O. Lamb

Submitted in partial fulfilment of
the degree of Doctor of Philosophy
awarded by the Royal College of Art

June 2014

Made possible
with generous support from
the Jack Kent Cooke Foundation

This text represents a submission for the degree of Doctor of Philosophy at the Royal College of Art. This copy has been supplied for the purpose of research for private study, on the understanding that it is copyright material, and that no quotation from the thesis may be published without proper acknowledgement.

The production of acoustic music bridges two senses—touch and hearing—by connecting physical movements, gestures, and tactile interactions with the creation of sound. Mastery of acoustic music depends on the development and refinement of muscle memory and ear training in concert. This process leads to a capacity for great depth of expression even though the actual timbral palette of each given acoustic instrument is relatively limited. By contrast, modern modes of music creation involving recorded music and digital sound manipulation sacrifice this immediate bridge and substitute more abstract processes that enable sonic possibilities extending far beyond the acoustic palette. Mastery in abstract approaches to music making doesn't necessarily rely on muscle memory or ear training, as many key processes do not need to happen in real-time. This freedom from the limits of time and practiced physical manipulation radically increases the range of achievable sounds, rhythms and effects, but sometimes results in a loss of subtlety of expressiveness.

This practice-based PhD asks whether it is possible, and if so how, to achieve an integration of relevant sensor technologies, design concepts, and formation techniques to create a new kind of musical instrument and sound creation tool that bridges this gap with a satisfying result for musicians and composers. In other words, can one create new, multi-dimensional interfaces which provide more effective ways to control the expressive capabilities of digital music creation in real-time? In particular, can one build on the intuitive, logical, and well-known layout of the piano keyboard to create a new instrument that more fully enables both continuous and discrete approaches to music making?

My research practice proposes a new musical instrument called the Seaboard, documents its invention, development, design, and refinement, and evaluates the extent to which it positively answers the above question. The Seaboard is a reinterpretation of the piano keyboard as a soft, continuous wavelike surface that places polyphonic pitch bend, vibrato and continuous touch right at the musician's fingertips. The addition of new real-time parameters to a familiar layout means it combines the intuitiveness of the traditional instrument with some of the versatility of digital technology.

Designing and prototyping the Seaboard to the point of successfully proving that a new synthesis between acoustic techniques and digital technologies is possible is shown to require significant coordination and integration of a range of technical disciplines. The research approach has been to build and refine a series of prototypes that successively grapple with the integration of these elements, whilst rigorously documenting the design issues, engineering challenges, and ultimate decisions that determine whether an intervention in the field of musical instrumentation is fruitful.

*The movement of your finger
Is not separate from your finger*

*You go to sleep, or you die,
And there's no intelligent motion.*

*Then you wake,
And your fingers
Fill with meanings.¹*

— Jelalludin Rumi, 13th Century

Contents	
List of figures	9
List of videos	17
List of audio	19
Preface	21
Acknowledgments	31
Author's declaration	33
Part 1. Context	
From the immediate to the abstract	35
Chapter 1. The immediacy of sound	37
Chapter 2. The keyboard: discrete continuity	49
Chapter 3. Reproduction, the digital, and abstraction	57
Part 2. Practice	
Invention, development, and refinement of the Seaboard	68
Chapter 4. Invention	70
Chapter 5. Research methodology	76
Chapter 6. Concept design	84
Chapter 7. Technology development	89
Chapter 8. Integrated proof of concept	94
Chapter 9. Product concept design	98
Chapter 10. Integrated proof or product concept	106
Part 3. Results	
The Seaboard GRAND and beyond	112
Chapter 11. The Seaboard GRAND	114
Chapter 12. Next steps	118
Chapter 13. Conclusions	124
Appendix	
A. Annotated figures	134
B. Annotated videos	412
C. Annotated audio	450
D. Research timeline	484
E. Component overview	451
Glossary	494
Bibliography	524
Index	539
Endnotes	541

List of figures

01	Chinese Ke (front perspective)	circa 2050 B.C.
02	Monochord (top view)	circa 582 B.C.
03	Pythagoras	circa 570 – 496 B.C.
04	Hydraulis	circa 100 B.C.
05	Clavieytherium (front perspective)	circa 14th Century
06	Clavichord (left perspective)	circa 16th Century
07	Spinnet (front perspective)	circa 1540
08	Queen Elizabeth Virginal (front perspective)	circa 1594
09	Reproduction Clavichord (front perspective)	circa 21st Century
10	Pipe Organ (front view)	1850
11	Harpsichord (right perspective)	1744
12	Harp (left perspective)	1785
13	Ancient Organ	circa 1620
14	Cathedral Organ (front perspective)	circa 14th – 15th Century
15	Clavichord (front perspective)	1763
16	Bartolomeo Cristofori	1655 - 1731
17	Square Piano Forte (right perspective)	circa 18th Century
18	Upright Piano (front perspective)	circa 1869
19	Yamaha A1L Baby Grand Piano (right perspective)	2014
20	Da Vinci Piano (back perspective)	circa 2013
21	Fluid Piano (left perspective)	circa 2010
22	Thomas Edison	1847 – 1941
23	Edison’s Home Phonograph (front perspective)	1896
24	Theremin (left perspective)	circa 1918 - 1928
25	Ondes Martenot (front perspective)	circa 1928
26	Ondes Martenot at the Paris World Fair	1937
27	Hammond Novachord (front perspective)	circa 1935
28	Novachord (left perspective)	circa 1939
29	Rhodes Army Air Corps Piano (left perspective)	circa 1942-5
30	Rhodes Pre-Piano (front perspective)	1946
31	Hammond Organ (front perspective)	1948-51
32	Fender Piano Bass (front perspective)	1959
33	Robert Moog	1934 - 2005
34	Moog Modular Synthesizer (front perspective)	1964-81
35	Tone Generator X-66 (right perspective)	1967-73
36	Fender Rhodes Mark 1 Stage (right perspective)	1969-75
37	Fender Rhodes Stage Piano (front perspective)	1967-75

38	Moog Mini Moog (front perspective)	1970-82
39	Wurlitzer Orbit III (left perspective)	1971
40	Hammond 102200 (right perspective)	1974-75
41	Yamaha CS-80 (front perspective)	1977-9
42	Sequential Circuits Prophet 5 (left perspective)	1978-84
43	Yamaha DX7 (left perspective)	1983-87
44	Kurzweil K250 (front perspective)	1984-90
45	Clavia Nord Lead (front perspective)	circa 1995
46	Nord Rack 2X Virtual Analogue (top view)	circa 2010
47	Nord Rack 2X Virtual Analogue (right perspective)	circa 2010
48	Nord Rack 2X Virtual Analogue (left elevation)	circa 2010
49	Haken Continuum case (top view)	circa 1998
50	Haken Continuum open case (top view)	circa 1998
51	Haken Continuum (top view)	circa 1998
52	Haken Continuum (right perspective)	circa 1998
53	Haken Continuum (side perspective)	circa 1998
54	Haken Continuum (side elevation)	circa 1998
55	Haken Continuum key top (top view detail)	circa 1998
56	Eagan Matrix (screenshot)	circa 2013
57	Reactable Live (front perspective)	circa 2003
58	Reactable by MOS "Luxury" (front perspective)	circa 2010
59	Reactable mobile UX (screen view)	circa 2010
60	Hecscan Rollup Piano (left perspective)	circa 2004
61	Electromagnetic sustained Rhodes Piano (top view detail)	circa 2011
62	Arp 26000 (front perspective)	1971-1980
63	Arturia ARP 2600V (screenshot)	2004
64	Bosendorfer 290 SE Recording Piano	circa 1984-1986
65	CEUS Bosendorfer (right perspective)	2006
66	Magnetic Resonator Piano (top perspective)	circa 2009
67	Infinite Response VAX77 MIDI Keyboard (front perspective)	2009
68	SLABS (top perspective)	circa 2009
69	Hyperkeys (right perspective)	circa 2010
70	Hyperkeys 3D music editor GUI (screenshot)	circa 2000s
71	Novation Mininova Synthesizer PP unit (front view)	circa 2012
72	Novation Mininova Synthesizer PP unit (left view)	circa 2012
73	Touchkeys (top view)	January 2014
74	Touchkeys (back elevation)	January 2014
75	Touchkeys without topcase (top view)	January 2014
76	Touchkeys (right perspective)	January 2014

77	Touchkeys (top view)	January 2014
78	Continuous keywave concept design	January-May 2009
79	Key volume concept design	January-May 2009
80	Key volume glissando concept design	January-May 2009
81	Dual-axis concept design	January-May 2009
82	Tri-axis concept design	January-May 2009
83	Mechanical pitchbending concept design	January-May 2009
84	Key interface concept design	January-May 2009
85	GUI concept design	January-May 2009
86	Soft surface keyboard interface idea	January-May 2009
87	Silicone sample concept design (top view)	January-May 2009
88	Silicone research samples (right perspective)	January-May 2009
89	Silicone research samples (right perspective detail)	January-May 2009
90	Pointed key volume design trial clay mold (top view)	January-May 2009
91	Pointed key volume design trial clay mold (right perspective)	January-May 2009
92	Rounded key volume design trial clay mold (top view)	January-May 2009
93	Seaboard 1 keywave CAD drawing (right perspective)	April-July 2009
94	Curved piano design	circa 20 th Century
95	Seaboard 1 CAD rendering (top view)	April-July 2009
96	Seaboard 1 key volume CAD rendering (left perspective detail)	April-July 2009
97	Seaboard 1 key volume CAD rendering (left perspective detail)	April - July 2009
98	Seaboard 1 rendering (right perspective)	April-July 2009
99	Seaboard 1 key ribbon casting (right perspective)	April-July 2009
100	Seaboard 1 partial cast (left perspective)	April-July 2009
101	Seaboard 1 cast trial (left perspective)	April-July 2009
102	Seaboard 1 keys (left perspective detail)	April - July 2009
103	Seaboard 1 (top view)	April-July 2009
104	Seaboard 1 (front elevation)	April-July 2009
105	Seaboard 1 (left perspective)	April-July 2009
106	Seaboard 1 and generic stand (right perspective)	April-July 2009
107	Seaboard 1 and generic stand (left perspective)	April-July 2009
108	Seaboard 2 sample cast (top view)	July 2009-January 2010
109	Seaboard 2 cast (top view)	July 2009-January 2010
110	Seaboard 2 internal electronics (right perspective)	July 2009-January 2010
111	Seaboard 2 and case (video screen shot)	July 2009-January 2010

112	Seaboard 2 sensor alignment (front perspective)	July 2009-January 2010
113	Seaboard 2 sensor alignment (left perspective)	July 2009-January 2010
114	Seaboard 3 chassis inner panel design	February – September 2010
115	Seaboard 3 chassis part connection design	February – September 2010
116	Seaboard 3 2D design drawing (multi-view)	February – September 2010
117	Seaboard 3 and stand rendering (front perspective)	February – September 2010
118	Seaboard 3 and stand rendering (right perspective)	February – September 2010
119	Seaboard 3 and stand rendering (right perspective)	February – September 2010
120	Seaboard 3 and stand rendering (top view)	February – September 2010
121	Seaboard 3 keys (top view detail)	February – September 2010
122	Seaboard 3 mold (top view)	February – September 2010
123	Seaboard 3 PCB (front view)	February – September 2010
124	Seaboard 3 sensor to PCB connection (left perspective detail)	February – September 2010
125	Seaboard 3 display set-up at the RCA Masters Design Show (right perspective)	February – September 2010
126	Seaboard 3 partial cast (right perspective detail)	February – September 2010
127	Seaboard 3 (right perspective)	February – September 2010
128	Seaboard 3 GUI (screen view)	February – September 2010
129	Seaboard 3 GUI (screen view)	February – September 2010
130	Seaboard 3 GUI (screen view)	February – September 2010
131	Seaboard 3 GUI (screen view)	February – September 2010
132	Seaboard 3 GUI (screen view)	February – September 2010
133	Canon digital camera (detail)	circa 2012
134	iPod (detail)	circa 2010
135	Mac Book Pro (detail)	2010
136	Audi Piano Design (back perspective)	2006
137	Audi Piano Design (front detail)	2006
138	B&W Speaker 800 Series Diamond (detail)	2012
139	Modern digital piano (detail)	circa 2005
140	Nokia Lumia back (back view)	circa 2011
141	Porsche Piano (right perspective)	circa 2003
142	Porsche Piano Pedal (detail)	circa 2003
143	Seaboard LUTE A 2D drawing	April – September 2011
144	Seaboard LUTE A exploded isometric drawing	April – September 2011
145	Seaboard LUTE A internal structure	April – September 2011
146	Seaboard LUTE A rendering	April – September 2011
147	Seaboard LUTE A rendering	April – September 2011
148	Seaboard LUTE A top chassis alignment (back perspective)	April – September 2011
149	Seaboard LUTE A silicone alignment (back perspective)	

		April – September 2011
150	Seaboard LUTE A top chassis alignment (back perspective)	April – September 2011
151	Seaboard LUTE A (right perspective)	April – September 2011
152	Seaboard LUTE A (back perspective)	April – September 2011
153	Seaboard LUTE B Technology Development (front perspective)	August – November 2011
154	Seaboard LUTE B top chassis (top view)	August – November 2011
155	Seaboard LUTE B top chassis (front elevation)	August – November 2011
156	Seaboard LUTE B top chassis (left perspective)	August – November 2011
157	Seaboard LUTE B top chassis (left side perspective)	August – November 2011
158	Seaboard LUTE C chassis (right perspective detail)	October 2011 – July 2012
159	Seaboard LUTE C assembled (left perspective)	October 2011 – July 2012
160	Seaboard LUTE C (top view)	October 2011 – July 2012
161	Seaboard LUTE C (front elevation)	October 2011 – July 2012
162	Seaboard LUTE C (right perspective detail)	October 2011 – July 2012
163	Seaboard LUTE C and generic stand (right perspective)	October 2011 – July 2011
164	Seaboard LUTE C cable management	June 2012
165	Seaboard LUTE D 2D drawing (multi-view)	June – September 2012
166	Seaboard LUTE D rendering (front perspective)	June – September 2012
167	Seaboard LUTE D top chassis (top view)	June – September 2012
168	Seaboard LUTE D top chassis (front elevation)	June – September 2012
169	Seaboard LUTE D top chassis (right perspective)	June – September 2012
170	Seaboard LUTE D top chassis (right side perspective)	June – September 2012
171	Seaboard LUTE D top chassis (back elevation)	June – September 2012
172	Seaboard LUTE D top chassis (back elevation)	June – September 2012
173	Seaboard LUTE D and generic stand (front perspective)	June – September 2012
174	Seaboard LUTE D Sound Dial (left perspective detail)	June – September 2012
175	Seaboard LUTE D and generic stand (right perspective detail)	June – September 2012
176	Seaboard LUTE D (left side detail)	June – September 2012
177	Seaboard LUTE D and generic stand (right perspective)	June – September 2012
178	Seaboard LUTE D# 2D drawing (multi-view)	June – September 2012
179	Seaboard LUTE D# chassis (front elevation)	June – September 2012
180	Seaboard LUTE D# chassis (left side perspective)	June – September 2012

181	Seaboard LUTE D# chassis (back elevation)	June – September 2012
182	Seaboard LUTE D# chassis (right perspective)	June – September 2012
183	Seaboard LUTE D# (top view)	June – September 2012
184	Seaboard LUTE D# (front elevation)	June – September 2012
185	Seaboard LUTE D# (right perspective)	June – September 2012
186	Seaboard LUTE E chassis (internal view)	August 2012
187	Seaboard LUTE E sensor array (detail)	August 2012
188	Seaboard LUTE E (right perspective detail)	August – November 2012
189	Seaboard LUTE E (right perspective)	August – November 2012
190	Seaboard LUTE E (back perspective)	August – November 2012
191	Seaboard LUTE E# 2D drawing (multi-view)	August – November 2012
192	Seaboard LUTE GUI (screenshot)	October 2012
193	Seaboard GRAND A 2D drawing (multi-view)	October 2012 – January 2013
194	Seaboard GRAND A chassis (top view)	October 2012 – January 2013
195	Seaboard GRAND A chassis and sensors (top view)	October 2012 – January 2013
196	Seaboard GRAND A chassis and sensors (front elevation)	October 2012 – January 2013
197	Seaboard GRAND A chassis and sensors (right perspective)	October 2012 – January 2013
198	Seaboard GRAND A chassis and sensors (right perspective detail)	October 2012 – January 2013
199	Seaboard GRAND A chassis and sensors (right side perspective)	October 2012 – January 2013
200	Seaboard GRAND A chassis and sensors (back elevation)	October 2012 – January 2013
201	Seaboard GRAND A (top view)	October 2012 – January 2013
202	Seaboard GRAND A (front perspective)	October 2012 – January 2013
203	Seaboard GRAND A (right perspective)	October 2012 – January 2013
204	Seaboard GRAND B 2D drawing (multi-view)	November 2012 – April 2013
205	Seaboard GRAND B (top view)	November 2012 – April 2013
206	Seaboard GRAND B Sound Dial (detail)	November 2012 – April 2013
207	Seaboard GRAND B (front elevation)	November 2012 – April 2013
208	Seaboard GRAND B (right perspective)	November 2012 – April 2013
209	Seaboard GRAND B (left side perspective)	November 2012 – April 2013
210	Seaboard GRAND B (back elevation)	November 2012 – April 2013
211	Seaboard GRAND B silicone (right perspective detail)	November 2012 – April 2013
212	Seaboard GRAND B stand bed (top view)	November 2012 – April 2013
213	Seaboard GRAND B stand bed (front elevation)	November 2012 – April 2013
214	Seaboard GRAND B stand bed (right perspective)	November 2012 – April 2013
215	Seaboard GRAND B stand bed (right perspective detail)	November 2012 – April 2013

216	Seaboard GRAND B stand bed (right side perspective)	November 2012 – April 2013
217	Seaboard GRAND C 2D drawing (multi-view)	January – July 2013
218	Seaboard GRAND LFE 2D drawing (multi-view)	April 2013 – May 2014
219	Seaboard GRAND LFE, STAGE, STUDIO assembly (right perspective)	April 2013 – May 2014
220	LFE assembly sensor alignment (right perspective detail)	April 2013 – May 2014
221	LFE assembly sensor alignment (left perspective detail)	April 2013 – May 2014
222	LFE assembly PCB (back perspective)	April 2013 – May 2014
223	Seaboard GRAND LFE (top view)	July 2013 – May 2014
224	Seaboard GRAND LFE (left perspective detail)	July 2013 – May 2014
225	Seaboard GRAND LFE (back perspective detail)	July 2013 – May 2014
226	Seaboard GRAND LFE (chassis corner detail)	July 2013 – May 2014
227	Seaboard GRAND LFE stand pre assembly (top view)	July 2013 – May 2014
228	Seaboard GRAND LFE stand (top view detail)	July 2013 – May 2014
229	Seaboard GRAND LFE stand (right perspective view)	July 2013 – May 2014
230	Seaboard GRAND LFE and stand (front perspective detail)	July 2013 – May 2014
231	Seaboard GRAND LFE and stand (right perspective)	July 2013 – May 2014
232	Seaboard GRAND LFE and stand (front perspective)	July 2013 – May 2014
233	Seaboard GRAND LFE and stand (left perspective)	July 2013 – May 2014
234	Seaboard GRAND LFE and stand (left side perspective)	July 2013 – May 2014
235	Seaboard GRAND LFE (left perspective)	July 2013
236	Seaboard GRAND LFE (left perspective)	July 2013
237	Seaboard GRAND LFE (left perspective)	July 2013
238	Seaboard GRAND LFE (left perspective)	July 2013
239	Seaboard GRAND STAGE 2D drawing (multi-view)	July 2013 – May 2014
240	Seaboard GRAND STAGE (top view)	July 2013 – May 2014
241	Seaboard GRAND STAGE (front elevation)	July 2013 – May 2014
242	Seaboard GRAND STAGE (left perspective)	July 2013 – May 2014
243	Seaboard GRAND STAGE (right side perspective)	July 2013 – May 2014
244	Seaboard GRAND STAGE (back view detail)	July 2013 – May 2014
245	Seaboard GRAND STAGE in studio context (top view)	August 2013
246	Seaboard GRAND STUDIO (multi-view)	July 2013 – May 2014
247	Seaboard GRAND STUDIO (top view)	July 2013 – May 2014
248	Seaboard GRAND STUDIO (right perspective)	July 2013 – May 2014
249	Seaboard GRAND STUDIO (right perspective)	July 2013 – May 2014
250	Seaboard GRAND STUDIO Sound Dial (detail)	July 2013 – May 2014

251	Seaboard GRAND STUDIO (back elevation)	July 2013 – May 2014
252	Seaboard GRAND STUDIO (back perspective)	July 2013 – May 2014
	Seaboard GRAND STUDIO in context (right perspective)	July 2013 – May 2014
253	Seaboard GRAND LFE, STAGE, STUDIO Sound Dial (top view)	July 2013 – May 2014
254	Seaboard GRAND LFE, STAGE, STUDIO Sound Dial (back view)	July 2013 – May 2014
255	Seaboard GRAND LFE, STAGE, STUDIO Sound Dial (face down elevation)	July 2013 – May 2014
256	Seaboard GRAND LFE, STAGE, STUDIO Sound Dial in chassis (back view)	July 2013 – May 2014
257	Seaboard GRAND LFE, STAGE, STUDIO Sound Dial pre assembly (top view)	July 2013 – May 2014
258	Seaboard GRAND LFE internal parts pre assembly (top view)	July 2013 – May 2014
259	Seaboard GRAND LFE hardware assembly tools (top view)	July 2013 – May 2014
260	Seaboard GRAND Software (SGS) (screenshot)	February 2014
261	Seaboard GRAND Software (SGS) (screen view)	February 2014
262	Seaboard GRAND EPP case (front elevation)	July 2013 – May 2014
263	Seaboard GRAND EPP case (bottom view)	July 2013 – May 2014
264	Seaboard GRAND EPP case (right perspective)	July 2013 – May 2014
265	Seaboard GRAND EPP case (right side perspective)	July 2013 – May 2014
266	Seaboard GRAND EPP case (back elevation)	July 2013 – May 2014
267	Seaboard GRAND EPP case monogram (top view detail)	July 2013 – May 2014
268	Seaboard GRAND EPP open case (right perspective view)	July 2013 – May 2014
269	Seaboard GRAND EPP open case (top view)	July 2013 – May 2014
270	Seaboard GRAND EPP open case with LFE (top view)	July 2013 – May 2014
271	Seaboard GRAND EPP case fastener (right perspective detail)	July 2013 – May 2014
272	Seaboard GRAND EPP case handle (top left view detail)	July 2013 – May 2014
273	Seaboard GRAND open EPP case handle (left perspective detail)	July 2013 – May 2014
274	Seaboard GRAND EPP case interior (right perspective detail)	July 2013 – May 2014
275	First Seaboard LFE ship day with the ROLI team	February 2014

List of videos

01	Pitch wheel demo	January 2010
02	Seaboard interaction concept design	February 2009
03	Seaboard 1 simulation	May 2009
04	Seaboard 1 stop motion	August 2009
05	Seaboard 2 demo	January 2010
06	Seaboard 2 with GUI demo	January 2010
07	Seaboard 2 GUI screen close up demo	January 2010
08	Seaboard animated introduction	August 2010
09	Seaboard 3 split screen demo	August 2010
10	Michael Price interview	November 2010
11	Seaboard 3 and electronic chromatic chords	May 2011
12	Seaboard 3 demo	May 2011
13	Seaboard 3 development and impact	May 2011
14	Seaboard 3 Pather Panchali	May 2011
15	Seaboard 3 Summertime	June 2011
16	Seaboard 3 Chopin performance	June 2011
17	Kunihiro Takei interview	December 2011
18	Seaboard Canon advert	May 2012
19	Jordan Rudess Seaboard LUTE demo	March 2013
20	Imagining the Seaboard	November 2013
21	Crafting the Seaboard	November 2013
22	Exploring the Seaboard	April 2013
23	Introducing the Seaboard	November 2013
24	Jamie Cullum and the Seaboard GRAND	August 2013
25	Seaboard GRAND performance (Moonwalk)	November 2013
26	Seaboard GRAND performance (Prokofiev)	November 2013
27	Seaboard GRAND performance (Percussion)	November 2013
28	Seaboard GRAND performance (Satie)	November 2013
29	Seaboard GRAND performance (Starfield)	November 2013
30	Seaboard GRAND performance (Mystic)	November 2013
31	Seaboard GRAND performance (Naima 1)	March 2013
32	Seaboard GRAND performance (Naima 2)	November 2013
33	Hans Zimmer and the Seaboard CNN feature	December 2013
34	Corey Henry demos the Seaboard at NAMM	January 2014
35	Rob Gentry demos the Seaboard at IRCAM	January 2014
36	ROLI SoundHive featured artist session 1	October 2013

List of audio

01	A Bending Rhodes	September 2010
02	Blackbird	August 2011
03	Mozart alla Turca	August 2011
04	Chopin Nocturne in C	September 2011
05	Amelie	December 2012
06	Mysterious	January 2013
07	Coltrane	February 2013
08	Bellatrix	April 2013
09	Classical guitar	April 2013
10	Percussive variation	April 2013
11	Western fusion	May 2013
12	Fairy loop	June 2013
13	African fantasy	July 2013
14	Fretless	August 2013
15	India	August 2013
16	Sahara dream	August 2013
17	Slide guitar	August 2013
18	Wudan path	August 2013
19	Claire de Lune	September 2013
20	Nostalgic afterthought	January 2014
21	Drive	February 2014
22	Decryption	March 2014
23	Eruption guitar solo	March 2014
24	Mellow horn	March 2014
25	Acoustic piano	April 2014
26	Clarinet rhapsody in blue	April 2014
27	Fusor dynamic EP	April 2014
28	Horizon	April 2014
29	Tears in the rain	April 2014
30	Dirt ribbon	April 2014
31	Flute	April 2014
32	Jazz guitar	April 2014
33	Oboe	April 2014
34	Upright bass	April 2014

Years ago I realized that the recording studio was becoming a musical instrument. I even lectured about it, proclaiming that "by turning sound into malleable material, studios invite you to construct new worlds of sounds as painters construct worlds of form and color." I was thrilled at how people were using studios to make music that otherwise simply could not exist. Studios opened up possibilities. But now I'm struck by the insidious, computer-driven tendency to take things out of the domain of muscular activity and put them into the domain of mental activity. This transfer is not paying off. Sure, muscles are unreliable, but they represent several million years of accumulated finesse. Musicians enjoy drawing on that finesse (and audiences respond to its exercise), so when muscular activity is rendered useless, the creative process is frustrated. No wonder artists who can afford the best of anything keep buying "retro" electronics and instruments, and revert to retro media.²

—Brian Eno, 1999

Music is a form of cultural practice that creates connections between touch, sound, and emotion. Because of the importance and intimacy of these connections, new instruments are considered unfamiliar and strange, even though some later come to be so indelibly linked our aural landscape that it is hard to imagine the sonic world without them. Despite this, the sources of new freedom in one era often become the limiting factors of the next. In 1917, Edgar Varese wrote:

I dream of instruments obedient to my thought and which with their contribution of a whole new world of unsuspected sounds, will lend themselves to the exigencies of my inner rhythm.³

Musicians, like Varese, wish for new powers of expression. And yet sometimes, in Faustian fashion, they then feel trapped by them. The division identified in 1999 by Brian Eno between the worlds of technological music production and intuitive acoustic music creation is no less wide today, fifteen years later. The increasing power of personal computers and tablet apps has meant that more and more people have access to music production tools, but the essential divide between the two types of tools hasn't been effectively bridged through innovations in technology or design.

The conflict that Eno identifies between the promise of being able to "construct new worlds of sounds as painters construct worlds of form and color," and the reality of the primacy of "several million years of accumulated finesse" forms the basis of this practice-based PhD work.

In the history of musical instrumentation to date, two types of tools have been central in many types of music performance, production, and composition: immediate acoustic tools, and abstract non-acoustic ones. The first, more traditional, approach is exemplified by the piano keyboard interface, which provides a clear and logical layout for controlling multiple pitched notes at the same time. Another type of tool that has become indispensable is digital applications for creating and editing sounds, as they enable a huge sonic and timbral range, all from a single device.

Although these two types of tools are used together every day in studios around the world, they nevertheless represent two poorly integrated approaches. Keyboards enable melodies, harmonies, and voicings to be controlled in real time, meaning a musician can explore 'macroscopic' musical ideas through the act of playing, but they allow almost no direct control over modulations in the timbre of the sound other than through external dials and controls. Digital tools enable enormous control of timbral modulations, but they generally cannot be accessed in real-time using musical gestures. This gap creates inefficiency, frustration, and unnecessary friction in contemporary music making.

This thesis broadly asks and answers the following question: is it possible, and if so how, to achieve an integration of relevant sensor technologies and design concepts and techniques to create a new kind of musical instrument and sound creation tool with a satisfying result for practising performers, composers, and producers who have piano-playing skill? The piano has been selected as a starting point because it is a great performance instrument and general musical and composition tool, and remains the dominant normative interface for music creation. This PhD proposes a new musical instrument called the Seaboard as a positive answer to this question and documents the practice-based work that led to its development.

In this preface, I aim to do three things. Firstly, I briefly sketch the background to the question, and explain why it is relevant now. Secondly, I explain the plan of the work to orient the reader. And thirdly, I provide a short summary of the contexts in which the practical work was undertaken and their implications for the work.

Although the question as stated above asks simply whether it is possible to create “a new kind of” musical instrument with a “satisfying result,” the backdrop for this question lies in the history of acoustic and digital music. One of the central observations that led to this work was that the worlds of acoustic and digital music are divided (a theme that is explored in detail in Chapter 1). In short, the beginning of the 21st Century marks a moment in the history of the relationship between physical interaction and the production of sound when two key trends are colliding. The first trend is the continuing division between the real-time physicality of engagement required for mastery of acoustic music and the abstract conceptual engagement required for the creation of many forms of digital music. The second trend is the rapidly increasing availability of sensing and processing resources that enable new product formulations, which theoretically has the potential to unleash new products that bridge the gap between the digital and the acoustic. If this potential is realized, it will represent a watershed in the history of how people relate to sound. So, to the extent that the core question of the PhD addresses “a new kind” of musical instrument, it is particularly concerned with a new kind of musical instrument that combines the flexibility and range of digital music with the expressiveness and physical intimacy of acoustic music.

A second aspect of the question that bears further specification and contextualisation is “a satisfying result.” The division between digital and acoustic frameworks for music creation is a cause of significant frustration among musicians. The goal has been to investigate whether it is possible, and if so how, to create a new kind of instrument that satisfies performers, composers, and producers specifically in the sense that it reduces the frustration individuals within these communities feel in the face of a choice between what Eno calls “options vs. intimacy.”

This thesis is divided into three main parts. The first covers the history and background of acoustic and digital music; the second recounts the development of the Seaboard; the third documents the resulting design and the next steps in the continuing design process. These are followed by an extensive appendix that provides images, videos and audio examples that document the work and its use.

Part 1. Context: From the immediate to the abstract provides historical background and a contextual field survey in three chapters.

Chapter 1. The immediacy of sound specifically examines the relationship between forms of physical interaction and sound production. For the vast majority of evolutionary history, sound was exclusively experienced in conjunction with corresponding perceptible physical events. The divorcing of sound events from physical events created a historic rupture in human multi-sensory somatic–aural experience. Key concepts such as discreteness and continuity, immediacy, and abstraction are introduced and defined.

In *Chapter 2. The keyboard: discrete continuity*, the search for a starting point for a new approach to multi-sensory somatic–aural experience is examined through a retracing of a particular branch of the evolutionary tree of musical instruments – that of keyboards. In general, acoustic musical instruments are the physical objects which elicit forms of engagement that lead to the highest forms of somatic-aural experience. The logical layout of keyboards and their neat division of pitches has led to their frequent use in digital music. That—and the central normative role they play in music learning and theory—make them a powerful starting point for new ways of integrating digital and acoustic music in real time. The keyboard as an interface, however, has merely been a way of controlling a range of systems for sound production, and given that modern keyboards use a variety of external controls, I argue that they are the cultural heirs of the organ, and that it is in fact the pianoforte which provides a better starting point for a new approach to real-time expression.

In *Chapter 3. Reproduction, the digital, and abstraction*, the rise of electronic and then digital approaches to sound creation is investigated in relation to the new possibilities of experience it enables as well as the problems that arise in the wake of a Pandora’s box of options that cannot be physically accessed in real-time.

Part 2: Practice: Invention, development, and refinement of the Seaboard documents the development of the Seaboard concept, the technological challenges that were overcome, and the design language that was crafted to transform the Seaboard from an idea into a finished product.

Chapter 4. Invention documents the development of fundamental key concepts of the Seaboard, beginning with their inspiration and following through their development to a fully-fledged idea. From early sketches and concept prototypes, as well as from instruments that served as an inspiration for the concepts, the chapter explores the ideas of musical intuition and multi-dimensionality which are at the core of the Seaboard concept.

In *Chapter 5. Research methodology*, some of the main methodological approaches are discussed, looking at systematic and practical concerns, and specifying the approach to documentation. It covers some of the challenges of applying a given methodology when dealing with new subject matter.

Chapter 6. Concept design recounts the development of the first Seaboard concept prototype, and the process of taking an idea and turning it into a physical object.

Chapter 7. Technology development delves into the technology research conducted in order to prove the concept through experimentation and prototyping.

Chapter 8. Integrated proof of concept documents the development of the Seaboard 3, the first integrated working prototype.

Chapter 9. Product concept design recounts the design decisions associated with the next phase of Seaboard prototypes, called the LUTE series. Given that the LUTEs were the beginning of the process of conceiving a first Seaboard product, the chapter presents the following problem: even the strongest interaction concept and technology demonstration requires a clear design strategy to ensure that the product projects itself into the imagination in the right way. In the case of a new kind of interface which straddles the acoustic and the digital, the question of how close the design language sits to technology is complex, just as is the question of how it should stand in relation to traditional acoustic instruments.

Chapter 10. Integrated proof of product concept covers the development of the Seaboard GRAND series prototypes, and deals with issues associated with sound development, case design, and prototyping the bespoke stand. This chapter also goes into greater depth with respect to the problems and opportunities associated with designing sounds for a new more dimensionally rich interface such as the Seaboard. Many of the categories of digital sound have been understood and conceived of in modular terms - this chapter documents the ways in which realising the potential of the Seaboard has meant developing a new approach to synthesis and the particular strategies employed.

Part 3. Results: The Seaboard GRAND and beyond presents the results of the practice-based design work, showing the final design decisions and documenting all aspects of the product. It further looks at the next steps, both with respect to the Seaboard and the technologies it uses.

Chapter 11. The Seaboard GRAND is organized into three sections. The first section presents all aspects of the physical design objectively with commentary about final design decisions. The second section examines the digital architecture and technology implementation in the product. And the third section presents the final sound design choices with further commentary.

In *Chapter 12. Next steps* the Seaboard is examined as a product family, and various issues are considered with respect to its continuing development and new use cases that might emerge as the design approaches evolve and the underlying technologies improve.

Finally, *Chapter 13. Conclusions* presents some salient lessons learned with respect to the construction of an interface of this type. Many of the lessons learned around the development, design, and refinement of the Seaboard have significance in other products and industries.

This main body of text is supported by an extensive appendix. A large number of annotated illustrations are presented, as is an annotated bibliography, among other supporting appendices. This is complimented by audio and video of the Seaboard made available through a CD that accompanies this text.

It may be useful to establish at the outset the particular context in which this work was developed, how I came to do it and why. I will briefly set out some of these particulars here.

I did not expect to do a practice-based PhD—nor did I expect my advanced studies to relate to design. Even as I completed my Bachelors degree in the spring of 2008, I had no inkling that I would begin to work in design and technology development.

My primary interests at the time lay in philosophy. My first degree concentrated in “Comparative Philosophy”. In particular, I studied Sanskrit and Chinese philosophy in order to build a methodology for thinking about the relationship between language and thought. My contention was that philosophical problems arise in three ways: the first are the problems which arise from particular social, cultural, and linguistic determinants. The second are problems which come from the structure of language and conceptual representation, and the third are actual paradoxes. I was especially interested in the second type, those that come from the structure of language, and I wanted to contribute

towards a method for telling the difference between the different types of philosophical problem.

I was also particularly concerned with two philosophical areas: process and structure in the context of mereology (the structural relationships between wholes and parts), and relationships between the material and the conceptual. These themes have both resurfaced in various ways in my continuing work.

I was very fortunate to win a Jack Kent Cooke Graduate Scholarship which provided for six years of graduate education anywhere in the world. In order to broaden my horizons, I wanted to explore the relationship between materiality and conceptuality from the material side rather than the other way around. My initial interest was in conceptual art, which used materiality as a staging ground for conceptual work. While looking at various places that I might do a Masters degree in this area before returning to a philosophy PhD, I came across the Design Products department at the RCA. I appreciated the more applied nature of design, and its greater proximity to technology, society, and mass commerce, and was attracted to the variety of approaches taken within the department.

I began my MA studies in 2009, and joined Platform 8, a platform with the Design Products department focussing on highly aesthetic, conceptual, and experimental approaches to design, then led by Gabi Klasmer and Julia Lohmann. Early on in the course, I signed up for a project organized by what was then Platform 2, led by Jurgen Bey and Martino Gamper, in collaboration with Yamaha. The project was called "Making Fun Serious" and the brief entailed the creation of new forms of instrumentation and musical experiment.

Participating in this project was a natural choice for me, as I was and am a practising jazz pianist. I have played the piano for most of my life, and devoted myself for several years to attain a reasonably high degree of technical competency. During the autumn of 2009, I wasn't sure how to find my feet in the design sphere as I had had little exposure, and didn't necessarily care enough about the issues that drive many designers. I cared deeply about the piano, though, and for this project, I proposed to attempt to augment the capacity of the piano.

I have been a piano player since childhood, and have always been a passionate disciple of the instrument, and a believer in its greatness. As much as I have always loved the piano, I was also keenly aware of its limitations. I would go out and play with other musicians, saxophone players and guitarists, and was musically envious of their ability to bend notes and change their timbre or mood midstream. I decided that it should be possible to combine the orchestral quality of the piano with the sensitivity and continuous

expressiveness of other instruments.

During the MA, I completed a concept prototype and then a first working prototype of the Seaboard. In the course of the work I did to develop the Seaboard, I realised that the technological approach I used to create a new kind of functional interface would have other applications and could be adapted to a variety of different form factors and functional areas. I decided to research these typological possibilities in the context of this practice-based PhD.

The only other contextualising note worth adding to this narrative relates to the commercial development of the Seaboard. Creating new interfaces is a high-risk and very expensive endeavour. Many tests fail, and all tests involve expensive material, components, and often the time and input of a wide range of people.

Although my Jack Kent Cooke Scholarship has generously supported my research, further funds have been required to continue the design development of the Seaboard and other interfaces. For this reason, continuing technical development has depended on the creation of a commercial vehicle which can justify the financial risk through the potential for financial rewards. Thus, even during my Masters I formed a company, ROLI Ltd (originally called Lambde Ltd), as a context for the commercial development of the Seaboard and other interfaces. In 2010, as I was starting my PhD research, the company accepted a convertible loan from the Design London Incubator, an RCA and Imperial College project funded by NESTA which has subsequently been folded into the InnovationRCA incubator.

Then, in 2011, ROLI Ltd was awarded three grants for research and development projects associated with the Seaboard. The first was a grant to support a six-month project (which was subsequently extended to 10 months) for an advanced proof of concept prototype. This project started in November 2011. The second grant supported lead user trials ensuring a good fit between the final product specifications and features and the addressable market. The third grant supported the development of a pre-production prototype.

In 2012, ROLI raised seed funding and repaid the InnovationRCA Incubator in full. Any proprietary techniques I have developed in relation to the Seaboard are owned not by me but by ROLI Ltd. Furthermore, a variety of collaborators have made contributions to the work, mostly in the context of work with the company. I have given appropriate credits for various contributions in the acknowledgments and the notes.

Firstly, a significant amount of work has gone into the development of the Seaboard to date on a wide variety of fronts. This has raised two issues associated with inclusion. The

first is that as there is an enormous amount of information, it has been necessary to focus on a few of the key themes involved. In particular, as this is a practice-based PhD in Design Products, I have focussed on the invention of the Seaboard, and the process of transforming the idea into a finished product. I might have focussed more on the materials science, hardware architecture, industrial engineering, or a number of other issues, but in this context issues relating to its design as a holistic product were paramount. Secondly, as the Seaboard has become a commercial product, some of the details of its material construction or the specifics of the algorithms developed to improved the functionality of the sensor interpretation should be treated as confidential and thus haven't been appropriate to include here. My specific criteria for inclusion is that if something is easy to grasp on an inspection of the finished product, I have included documentation and commentary on it, and if something is non-obvious, then I have usually not focussed on it. As it turns out, there haven't in fact been any conflicts between these two guiding principles. The high-level questions about the Seaboard as an instance of product design and the low-level issues of proprietary technologies are sufficiently distinct that the confidentiality with respect to the latter hasn't impeded scholarly publicity with respect to the former.

The fundamental subject matter of this PhD is interface design. Effective interface design necessarily involves creating a dynamic and generative interaction between the interior and the exterior of an object, between its structure and its surface. The interior, or body, of the work of this practice-based PhD has been studio-based design work. In a sense, the writing work provides an exterior, or a skin for that body.

For a user, the surface is sometimes the most important aspect of the interface because it is the primary site of interaction. Similarly, for a 'user' of this practice-based PhD (it might be too narrow to say reader, since this written work itself is intended as documentation of and guide to an active design practice) the writing can be seen as a conceptual interface with which to engage with the material and technological work involved in the innovation process undertaken. I hope this text provides an adequate interface to facilitate engagement with this project, from its conceptual framework, to its design and development process, to its tangible outputs.

Acknowledgements

Inventing and designing products, especially new technological products, is a daunting task. The sociality of collaboration is important not only because it affords a necessary division of labour and corresponding depth of specialization. The discussion, debate, and discovery that comes from working with others is an essential part of the decision-making process that is at the heart of bringing the new into the world. I have a long list of friends and collaborators to thank.

My tutors from the RCA, including Gareth Williams, Gabi Klasmer, and especially Ron Arad, without whom I probably wouldn't have attended the RCA and invented the Seaboard.

My PhD supervisor, Hilary French, played a crucial role in both supporting the work and providing clear valuable feedback and critique when needed. She encouraged me throughout the entire process and made sure that I stayed focussed on my research through all the vicissitudes of the project. Pattie Maes kindly served as an external supervisor and kind supporter, and David Wessel and Adrian Freed at the University of California Berkley gave me helpful feedback. Kunihiro Takei was a wonderful interlocutor for the early stages of the design process.

The ROLI development team has played a significant part in the development of the Seaboard over the last 3 years. On the physical side, I'd like to acknowledge the great work of Ning Xu, Tien-Sheng Huang, Jack Armitage, Hong-Yeul Eom, Heegun Koo, Gaetano Ling, Santiago Ortega, Yuta Sugawara and Ben Staines. In particular, Hong made an enormous contribution to the realisation of the final product - he has been one of my best teachers in the art of design.

On the digital side, Ben Supper, Teresa Bianchi, Angus Thomson, Silvère Letellier, Gregoire Lejay, Joe White, Christopher Fonseca, Sean Soraghan have all made major contributions to the development of a strong code base.

On sound and performance, Heen-Wah Wai, Hao Chen, Marco Parisi, Cory Henry and others have brought the best out of the Seaboard, while Rafael Szaban deserves special mention for his beautiful work on the Seaboard sounds. Lily Skove and TJ Hellmuth produced and directed some of the gorgeous short performances of the Seaboard.

The whole extended ROLI team deserves a big thank for their dedicated support and hard work making this document possible on several fronts, Julian Salaün, Zain Qazi, Patrick Gleeson, Minsu Kim, Mary Marcher, Jean-Baptiste Thiebaut, Danny White, Corey Harrower, Charles Cook, Lauren Ianni, Rami Naayem, Evan O'Brien, and Stephen Hempton. A special appreciation to Charles who helped me to carve out the necessary time to finish writing

whilst juggling other responsibilities, and moreover provide crucial last minute assistance with proofreading and final formatting. And to Corey for unimaginably steady support.

Outside of the main ROLI team, Andrew Robertson made a major contribution in the early stages of the project, and Andrew Macpherson deserves a special mention as he not only conducted excellent research in relation to TouchKeys which was invaluable in understanding the overlapping historical context for the Seaboard – he also kindly offered to serve as a reader at the last moment to help fill a crucial gap. Alex Hulme made an important contribution to the aesthetic conception of the product during the development of the LUTE series of prototypes.

Hans Zimmer provided extraordinarily deep feedback, and real encouragement about the importance of the Seaboard. Jordan Rudess has been a stalwart supporter and friend, bringing deep insight to the Seaboard and providing great feedback at every stage of the journey.

Many, many other friends, musicians, and Seaboard customers have given me great feedback and input during the course of the development of the Seaboard.

In preparing this document, Rami made a wonderful contribution perfecting the Appendix C and E. Heen-Wah Wai contributed not only by being a Seaboard maestro, but also in preparing the annotations for the audio and video appendices. Julian Salaun took the lead in taking many of the key images for the appendix.

Lauren Ianni, who was first my research assistant and later became the research and documentation coordinator at ROLI made a huge contribution to the whole effort, assembling all the key documentation and research materials, drafting glossary definitions and annotations, and patiently assisting on all fronts.

Finally, I'd like to thank my friends and extended family for never failing to believe in me and being patient with all my many projects. David Grewal resolutely encouraged me to push ahead with the research. My mother kindly provided copy edits at the last minute. My darling son Rumi, who cheerfully greeted me even after the days I spent in the studio and the library as I finished this PhD, and most of all I thank my wife, Tahmima Anam, who provided constant encouragement and insight over all the years leading up to the completion of this work, through the up-and downs, with supreme patience and loving support.

Author's declaration

During the period of registered study in which this thesis was prepared the author has not been registered for any other academic award or qualification.

The material included in this thesis has not been submitted wholly or in part for any academic award or qualification other than that for which it is now submitted.

Part 1. Context

From the immediate to the abstract

*The cultivation of the five senses is the work of all previous history.*⁴

—Karl Marx, 1844

1.1 Context

When I was a teenager, I used to collect beautiful antique frames – some I would fix up, others I would transform, and eventually I'd find the right one to fit a given photograph or painting. I was always struck by just how vividly the right frame would bring a work to life, alter the interior relationships between the forms and colors, and give it new shades of meaning.

This chapter and the two that follow provide a modicum of philosophical context, historical orientation, and critical distance to this design research and practice. Effectively adumbrating the background to any body of research depends on two things: knowing one's reader and knowing the scope of the questions to be answered.

The same framing that might be rudimentary for one reader will be too laden with specialist assumptions for another. In the following chapters, I have assumed a working knowledge of music, musical instrumentation, contemporary technology and industrial design. For some readers I may have spelled things out in more detail than may be necessary; please feel to pass through such sections quickly. For other readers, you may find that I have moved quite quickly through important topics, and hopefully if any terms are confusing, you should find definitions in the Glossary.

What needs be included and omitted will come down to the questions one is trying to answer, so let us briefly return to the questions at the heart of this design practice: can one create new multi-dimensional interfaces which provide more effective ways to control the expressive capabilities of digital music creation in real-time? In particular, can one build on the intuitive, logical, and well-known layout of the piano keyboard to create a new instrument that more fully enables both continuous and discrete approaches to music making, in which the benefits of use outweigh the challenges of learning?

In order to properly frame this question, and the practice-based research I have conducted to answer it, I begin by taking quite a big step back with a very broad consideration of the antecedents to music that emerge from the fundamental associative cognitive connection between touch, hearing, and the visual perception of movement. I do this mostly to provide background to the thematic concerns of discreteness and continuousness, two heuristic categories which help to contextualize some of the key design challenges faced.

In the end, the choice of frame is subjective, reflecting my interests and concerns more than anything else. This is appropriate though, because the most important things to contextualize in the context of a design practice are the values and thought-processes that drive the design conceptions and decisions at the heart of the practice.

1.2 Condition and sensation

Neuroscience may not be the foundation of design *per se*, but a strong understanding of the brain and the nature of sensation is a particularly important foundation for effective interface and interaction design. In other words, we can't think deeply about topics like our sensory relationship with technology if we don't start by looking closely at our senses—where they come from, how they are formed and operate in relationship to each other, and how they can be reformed and reshaped by particular material, social, and cultural conditions.

Sensations are generally understood to be the product of brain states, and these brain states are, in the majority of normal cases, caused by physical activity in the world that is 'picked up' by one of our sensory systems.⁵ Traditionally identified senses include sight, hearing, touch, taste, and smell. These five Aristotelian sense categories are somewhat arbitrary—there are several other internal senses such as pain and proprioception, and whatever the number, the senses are not necessarily discrete, and the connections between them are not entirely 'hardwired'. Fiona MacPherson, a contemporary scholar of the philosophy of the senses, writes:

There is evidence that many more than five sensory modalities *actually* exist. From these cases we can extrapolate and then come to believe that the number of possible sensory modalities is large.⁶

Reductionism should be rejected at the outset. Our brains are made up of billions of pathways and connections and remain the most complex reprogrammable sensory systems of which we are aware. The brain's extraordinarily deep information networks are characterized by a complex interplay of plasticity and rigidity. These neural networks are capable of enormous plasticity, since new connections can be easily made and assimilated, and these form the basis of conscious experience and our ability to learn and develop new pathways. At the same time, the fact that our brains have more rigidly established habits and modes of operation is the basis of our capacity to do many important and difficult tasks unconsciously, automatically, and without effort, and it is furthermore the basis of intuition. The same tasks which are difficult during a learning phase become automatic once the networks become rigidly established as a subconscious routine.

This interplay is key to an understanding of conscious and subconscious routines of the mind, and focus and awareness more broadly. It is also the key to understanding the extent to which the senses can and cannot be conditioned by their material and social environments.

To understand how the relationships between plasticity and rigidity define and are defined by the objects and contexts of our social world, we might more profitably turn from science to philosophy. Marx's famous comment that "the cultivation of the five senses is the work of all previous history" is preceded by a clearer insight:

For not only the five senses, but also the so-called spiritual senses, the practical senses (will, love, etc.), in a word, the human sense, the humanity of the senses – all these come into being only through the existence of their objects, through humanized nature.⁷

The senses, in Marx's view, are our windows into the world with their own given form, shape and limits, and yet we need the content of the world to develop them and enable them to come fully into a given particular being. Although he is right that the senses are conditioned by the objects and practices we find in our social worlds, it is also easy to observe ways in which the deep structural relationships between our senses condition the objects we use, enjoy, and create. The plasticity of our brains creates the power to reprogram and learn, whereas the rigidity of certain key associations also has a strong evolutionary and empowering function associated with automatic action, multi-tasking, and intuition. Thus, our sensations are neither an entirely discrete set of different senses operating in parallel as common sense and natural language might imply, nor an entirely, open, continuous, reprogrammable field.

The tension between plastic and fixed associations on the 'inside' and the material conditions of the senses on the 'outside' is reflected everywhere, including in the design and development of the tools we use, such that some awareness of this dialectic provides an important background for the conception of new objects that enhance and extend the senses.⁸

Even after post-modernism victoriously established that everything is to be understood as particular and resistant to generalization, certain cultural practices continue to appear to be universal. This is more than a dividing line between cultural theorists and evolutionary psychologists—it is another line between when we choose to trust or doubt our common 'sense'.

Music appears to be one such universally-shared cultural activity, albeit one that remains difficult to define precisely.⁹ A viable definition has to encompass a number of traditional and ritualistic approaches to the creation of rhythmic, melodic, harmonic sound, and more experimental explorations on the borders of bringing consciousness to noise. We hear music and want to create it. We reach for and learn the instruments available to us. We have a particular kind of experience while we play these instruments that is conditioned

by our senses and conditions our senses. And we create music that others may want to hear and emulate. Whether or not one commits to a final definition, it is clear that there are certain neurological, physiological, and technological antecedents to any given cultural practice of music, as well as necessary and evolving tensions between all three.

Because music is a set of cultural practices based on physiology and technology, the history of music and musical instrumentation provides a powerful case study in this dynamic of the dialogue between the received conditions and ongoing conditioning of the senses.

1.3 Touch and sound

Many social behaviors that we learn take conscious practice and support from our environments in a variety of ways, while other deep associations, for example associations between types of sensory information, seep in through structurally repetitive forms of experience. One important feature of the human brain which allows us to register large quantities of sensory data is our ability to correlate associations from one type of sensory data to another. Correlative associations can play an important role in understanding our field of experience through multi-modal confirmation and inferences, and therefore these associations become foundational to our intuitions and our sense of the real. We have to ask which sensory associations or bundling of sensory perceptions is fundamental to all human experience, and which forms are circumstantial, especially as bears on the background to music making.¹⁰

Sound is part of the fabric of our reality, and our experience of it is woven deeply into our minds and our intuitive understanding of the causal world. The study of sound and music has always been considered a key part of the endeavor of collective self-knowledge.

In the Greek and Roman worlds music, including whatever was known about musical acoustics, held a high place in science and philosophy. In the liberal arts of the Middle Ages, music was part of the higher *quadrivium*, along with arithmetic, geometry, and astronomy. The place of music in the liberal arts was above that of grammar, rhetoric, and logic, which constituted the lower *trivium* that dealt with words rather than numbers.¹¹

Sound is of course a physical phenomenon, vibrations that create mechanical waves in a given medium. But we usually don't feel sound—we hear it. Our perception of that movement takes place in a modality that is very different from our tactile perceptions. And yet, perhaps because both are fundamentally based on mechanical contact with a thing or a wave, sound and touch are neurologically deeply inter-conditioned. The correlation between perceptible physical events and sound is one of our mostly deeply ingrained associations, from our entire evolutionary history to the majority of our personal

experience.

Touch and hearing are two of the deepest senses, and the relationship between movement and sound is established from the earliest stages of life. From the womb and beyond, sound and touch are constantly occurring in parallel. When a baby cries, it hears its own sound at the same time it feels a vibration in its own vocal chords. Early on we come to cognise 'physical events' as a mental category, associating them with a cluster of particular sensations of sound and touch (and external movement). The relationship between impact, movement, and sound is one of the most deeply ingrained in all of human experience.

Near-field events that we perceive through sight or touch are usually accompanied by a sound of some kind, and more importantly, sounds are usually accompanied by a visible event. The association between seeing or feeling an impact, for example, and hearing a corresponding sound, is so automatic that were one to experience an impact without any sound it would be unintuitive and even unnerving. Similarly, a sound without a source in physical activity seems impossible. Indeed, sounds which don't automatically correlate to clear physical activity, like thunder, beg an explanation.

Hearing therefore functions as a mode of identification and can be used as a source of knowledge, both in the sense of knowing something about who or what else was nearby, as well as in the more profound sense of being the core medium of language. These highly conditioned neurological correlations between physiological experiences of touch, sound, and movement are an essential background to the core technologies of music making.¹²

1.4 Impact and vocalization

Building instruments means building new physical approaches to producing sound. To understand our physical approaches to sound, it is worth going back to the formative tools of our own bodies; the two most fundamental 'technologies' of music making are our vocal apparatus and our hands, or more broadly, the most basic musical tools are vocalization and impact.

Vocalisation is the tool of continuous sound, in which amplitude, pitch and timbre shift in real time. The vocal, because of its overlap with our voices and speech, is associated with meaning and emotion, and more broadly with individuality, interiority, subjectivity, and mentality. Indeed, we now understand voice as an instance of sound, but historically, argues Jonathan Sterne in *The Audible Past* "speech and music had been the general categories through which sound was understood."¹³ He writes:

Works of grammar and logic distinguished between significant and insignificant sounds by calling all significant sounds *vox*—voice. Other philosophers took music as an idealized theoretical instance of sound, leading to the analysis of pitch and harmony, all the way up to the harmony of the spheres, and for Saint Augustine, God. In contrast, the concept *frequency*—previously developed by Descartes, Mersenne, and Bernoulli—offered a way to think about sound as a form of motion or vibration.¹⁴

Even though we have come to understand sound scientifically as the propagation of a mechanical wave, intuitively voice is still the quintessential, defining instance of sound. And the emotive associations of voice and speech carry through not only to actual singing, but any monophonic melodic performance. Hearing a solo violin cannot but trigger the neurological habits that have come from a lifetime of vocal associations.¹⁵

The correlation between muscular skill and skillful sound production is similarly ingrained, from our entire mammalian evolutionary history to the majority of our personal experience. Animal-generated sounds have a wide range of communicative cross-species social effects, from soothing to threatening. Many of these are learned behaviors that rely on some level of muscular skill. In particular, more advanced mammals' capacity for speech-like sound is based on considerable skill. In human speech, the production of particular sounds is crucial to successful communication and each one involves a signature set of muscular actions which have to be executed precisely. Capability in this respect is generally considered a requirement of fully functioning as a human being, and so the association between extremely skillful use of ones' muscles to perform sound and thus communication is ubiquitous.

This emotive quality of various timbres—each dependent on a precise use of muscles—is also one of the foundations of vocal music. Thus we have a deeply ingrained association and corresponding set of intuitions which link highly-skilled muscular activity with not only physical events in general, but performative social acts which involve semantic meaning, emotive impact, and musical or proto-musical qualities. It is worth further noting that these associations are equally strong in relationship to self and other. Children can sometimes only be calmed by the cooing of their parents, and *Homo sapiens* as social animals look to others for many forms of support, from the practical to emotional. The (often tacit) knowledge that particular kinds of muscular precision are involved in acts of speech, emotively appropriate intonations and timbres, and musical performance, both one's own and that of others, is a source of differentiation, shared intelligence, and reciprocity. Indeed, recent research by Robert McCarthy at Florida Atlantic University found that Neanderthals, based on a reconstruction of their vocal tracts, would have been capable of producing fewer vowels than *Homo sapiens*, and thus would be limited in the range of vocabulary they could use. Our voices, perhaps more than anything else, evoke and validate our humanity.

Theories abound about why we make music, and indeed, what should be considered music. It is impossible to estimate when signing developed to a point that we might call music, but we do know that the oldest musical instruments date back 40 - 50,000 years to the upper Paleolithic age.¹⁶ The ability to use impact to create percussive sound is clearly far older than vocalization, although rhythm is probably far younger than melody. Speech has natural rhythms and cadences to it, but musical rhythm is a different matter,¹⁷ and the drum probably came relatively later in the evolution of the first musical instruments.

...[M]usic, and indeed percussion, can be traced back as far as almost any other aspect of civilization, but although drums are often carelessly talked about as the earliest instrument, this is unlikely. There is a big leap from scratching out an animal bone for a whistle to stretching a prepared animal skin over a hollow shell and securing it in that position with adequate tension to make a satisfying sound.¹⁸

Nevertheless, impact remains a fundamental tool in establishing pulse and alongside vocalization (whether made by a voice or a flute) is one of the earliest and most fundamental tools of sound creation. In *The Psychobiology of Musical Gesture: Innate Rhythm, Harmony and Melody in Movements of Narration*, Trevarthen, Delafield-Butt, and Schogler examine the extreme subtlety of the human hand as a complement to the human voice.

The motor-intentional possibilities of human upper limbs, and their demands for elaborate cerebral imaginative control, are very great, because the jointed lever system of arms, palms and fingers has many biomechanical degrees of freedom, and because the cerebral programming of the combinations of rotation about the joints is, from birth, extremely refined and informed by many sensitive receptors. Hands of adults can be projected from the body with high velocity to transmit large forces, moved with exquisite temporal and spatial precision of guidance in an extensive reaching field, and rotated to contact surfaces of objects with accuracy in any direction while responding to light touch, modulating pressure.¹⁹

This capacity of the hand is an important background to all musical expression but especially percussive touch. The range of velocities and speed of attack surpasses that of the voice, especially with the right tools, and these categories of melody and rhythm, voice and impact, are presaged by the structure of our minds:

Our cerebellum (or brain stem) has recognizable antecedent in reptiles. It controls motion and responds to rhythm. A repetitious sound appeals to the animal instinct, whereas tone quality and melody are processed by the cerebral cortex—as demonstrated by brain scans—and cater more to the highly developed human intellect. The need to reconcile these parallel inputs helps to complete the interlocking connections of the infant brain.²⁰

Musically, then, we don't just make fundamental associations between our sense of sound and touch; we associate vocal sound with internal movement and vibration, and percussive sound with external movement and impact. This leads us to the broader categories of continuity and discreteness, and a step closer to the problems addressed in the design practice.

1.5 Discreteness and continuity

Sound and touch are well-known categories, and vocalization and impact are easy to understand. To understand their meaning and significance, especially as pertains to the experience of creating music with respect to the role and scale of time, it is valuable to introduce two sets of more philosophical themes: discreteness and continuity, and abstraction and concreteness.

Discreteness, as I use it, refers to the characteristic of something being perceived in such a way or at such a rate that it appears to be a single thing, usually taking place in a clear and singular point in time and space. Continuity, on the other hand, refers to the characteristic of things that are perceived in ways or at rates such that internal change and variation is clear, and takes place across a given span of time or space.

I call these themes rather than terms, as I don't intend to propose them here in a philosophically rigorous way to make a purely philosophical argument. They are rather very general illustrative ideas which help to connect the physical, the musical and the experiential.

Perhaps it is clearer to explain by example. To begin with, a Euclidian point is a perfect emblem of discreteness, and a line an example of discreteness.²¹ Physically, steps are a set of discrete lines and a ramp is a continuous one. Piano keys, likewise, are discrete in relation to each other especially as pertains to initial pitch, whereas the active space of a Theremin with respect to pitch is clearly continuous. Even when comparing a fretless and fretted instrument, it is clear that one creates sets of discrete possibilities, where the other creates a continuous spectrum of possibilities.

Musically, discreteness and continuity map, to some extent, on the categories of impact and vocalizations, rhythm and melody. A rhythm is a set of discrete events that have a regular pattern in relation to each other. Rhythm is a set of parts creating a whole in time, and the nature of that whole can change over time, but the components are necessarily primarily perceived as discrete units. This discreteness of each event captures the sensation of impact, the experience of the instantaneous. A melody, while it may have separate, discrete notes, is a more continuous musical proposition. The use of legato or

glissando or slurs and vibrato: all of these bring elements of continual change and evolution. Even the strong tendency that a melody is played by a single continuous voice in a section of music, rather than having each instrument play a single note within a melody is evidence of the strongly continuous nature of melody as a subjective category. These continuous characteristics of melody are strongly related to the continuous characteristic of the voice. Obviously this doesn't mean that we can't vocalize discrete or percussive sounds, or that rhythms don't have continuous elements, or anything like that. These are simply helpful categories for understanding how a set of physical dynamics can relate to the production of musical sound.

And these categories can likewise relate to our bodies and gestures. Our bodies are in some broad sense complex and continuous, but there is a kind of discreteness to our fingers for example. And various gestures such as slapping, or stroking, flicking or twirling each have more discrete or continuous elements to them.

The themes of discreteness and continuity are also helpful in understanding our perceptual apparatus that sits in the background of our music making and listening. Neuroscientists are currently debating the extent to which our perception is best understood in continuous or discrete terms.²² And contemporary philosophers are finding new inspiration from understanding the discrete and continuous aspects of perception in evaluating old ideas.²³

We know that a set of discrete elements can create the illusion of continuity. Film is a perfect example. The reverse is less common in practice, although the general indeterminacy between particles and waves suggests that at a deep physical level continuity can equally create the illusion of discreteness.

Where the perceptual lines are drawn between the discrete and continuous comes down to the rate at which we process data. The discrete present, sometimes called "perceptual frames" is approximately 80- 200ms long.²⁴ One likewise can posit a continuous present, which would be, rather than the shortest period of perception, the longest period of possible perception which feels subjectively like a 'single' moment of perception.

So in summary, discreteness can mean a point in space or time, a step, a tap, a beat, a key, a fret, a frame, a moment of perception and in a sense, a part. Continuity, on the other hand, is a line, a span, a melody, a surface, a stroke, a string, an experience, and in a sense a whole.²⁵

1.6 Immediacy and abstraction

Now, right now. Indexicals of time, like 'now,' and 'today,' when performed, strongly

suggest a present reflection. How long is the now? What does instantaneous mean, and can we build meaningful categories for the understanding of musical production around such categories?

Although discreteness and continuity are very different, they are closely paired because they fundamentally relate to spatial and temporal relationships – they are both generally used to refer to immediate things and experiences. Here I contrast the immediacy of experienced time and space with abstraction. Abstraction occurs when something becomes unmoored from its locale of time or space. A Euclidian point or line is of course an abstract idea, but one which is so easy to apply in our experience of space that it feels quite concrete. Abstraction takes place when things become separated from their context, isolated, where spatial and temporal relationships break down or take unfamiliar and unintuitive form.

In the context of music, abstraction primarily refers to forms of music creation and consumption where the temporal relationship between the physical generation of sound and its use in music creation has been altered or transformed, and likewise where the point of musical creation and listening are separated in time and space. There is an immediacy to sitting in a room listening to someone play the piano, in which the real-time connections between what you see and hear and feel all combine into a closely-knit and intuitive whole, as opposed to a more abstract relationship in which one listens to music which necessarily is based on a given set of internal temporal relationships, but where the creation piece and all its elements represent physical events far removed in time and space.

1.7 Medium and message

To differentiate the synchronous immediate with the asynchronous abstract is not to make a statement of musical value; immediate music can be awful and abstract music wonderful, but as Brian Eno's quote at the beginning of the preface suggested, there are meaningful trade-offs between 'intimacy and options'—between 'several million years of accumulated finesse' and studios that 'opened up new possibilities.'²⁶

The medium is the message in the sense that particular approaches to music, particularly the macro-approaches of immediacy and abstraction carry with them very different sets of meanings for musician and listener. Genre is a product of instrumentation. And in a larger sense meta-genre is meta-instrumentation, meaning that what we understand to be traditional and contemporary approaches to music-making fundamentally comes down to the immediacy or abstraction involved in the music-creation process.

For music creators, there is an oil and water quality to the two approaches. The feeling of

strumming on a guitar and programming modulation data in a DAW sit at opposite ends of the experiential spectrum. This division is the source of real frustration for musicians. And it turns out, for complex reasons, abstract approaches to music making have been more successful when it comes to the creation of discrete, percussive sounds than they have in reaching the apex of expressive continuous melodic sound. Any innovation that lowers the barriers to entry also risks lowering the ceiling of possibility.

A common lament of the past decade has been that, despite the apparent power and diversity of new musical instruments and recording devices, everyone's work is beginning to sound the same. Musicians complained that the limited range of sounds built into some drum machines and synthesizers virtually forced them to write music in a particular style.²⁷

To understand the nature of this frustration, one has to take a much closer look at (a) the evolution of a particular kind of instrument and a corresponding particular form of hand skill; and (b) the particular character of developments in electronic and then digital music.

1.8 Keys and boards

With the advent of musical instruments, the site of skillful *continuous* sound production gradually moves from being the exclusive province of the vocal chords, tongue and mouth to being shared with the other most dexterous site of human muscular intelligence: the hand. The expressiveness we associated solely with vocal performance gradually began to be transplanted to include the performances of the hand. The human hand had already proved itself a source of impact and rhythm making, but now could show its tremendous subtlety and sensitivity. Musical performance has long been one of the most demanding and celebrated of all performances, elevating tool use to create anthropomorphized sound that stretches beyond what even the voice can do.

While many monophonic instruments bring more of the melodic qualities of the human voice, keyboards provide a powerful way of laying out pitch in a drum-like way. Indeed, the keyboard is a 'vocal drum.' The very name suggests a peculiar marriage: the keys are discrete; the board is continuous. To the extent that this design practice examines the themes of discreteness and continuity in musical interface, and immediacy and abstraction in contemporary music making, there is no better starting point than the piano keyboard.

...[I]f a new technology extends one or more of our senses outside us into the social world, then new ratios among all our senses will occur in that particular culture. It is comparable to what happens when a new note is added to a melody. And when the sense ratios alter in any culture, then what had appeared lucid before may suddenly be opaque, and what had been vague or opaque will become translucent....²⁸

—Marshall McLuhan, 1962

2.1 Ancient keyboards

It is no accident that keyboards have become a dominant interface for music composition and production around the world, and it is valuable to contextualize their musical role in their long history. Keyboards have a tremendous history, having been tempered, tuned, and refined for centuries, and have long earned their place at the physical and conceptual center of the orchestra.

Keyboards, in all their incarnations, have played a central role not only in the history of music but also in Western cultural history. Excellent books have been written about various detailed aspects of this history, providing excellent historical overviews complemented with vivid social history.²⁹ My intention here is not to provide a historical overview from the ancient past to the present, but rather to offer a prelude that examines some of the reasons why keyboards are an excellent starting point for a new bridging of the discrete and continuous.

One of the first instruments or tools to use a series of mechanized depressible 'keys' was the Greek water organ, or hydraulis. Although it is clear that the early hydraulis had keys, we don't know a great deal about the process of its invention and development. It is likely that the need for a particular keyboard was a by-product of the ability to produce a hydraulic sound. In fact, though, it is not even known for certain whether the primary function of the earliest examples of the hydraulis was to make sound or merely to use sound to demonstrate the basic technology.

Literary sources often refer to fingers playing on keys, but there can hardly have been anything of the finger technique familiar from the later fifteenth century. Written sources give little evidence on several of the most important factors, but iconography suggests that the pipes were usually flues, their diameter constant, their tuning not necessarily diatonic, chromatic or even enharmonic, and that chests with more than one rank may have produced different timbres and perhaps fifth-sounding ranks. None of these details is certain, however, and while the Aquincum organ confirms one or two of them, it is knowledge of the later organ that encourages us to read some of the other details into the evidence for the various kinds of classical hydraulis.³⁰

Nevertheless, if we look at the importance of the interface as an evolutionary success, we should credit not just the initial mutation that led to the invention but the functional advantages that led to widespread acceptance.

The early hydraulis would have likely had two functional advantages over other musical instruments of the time. First, because each channel of the hydraulis system, like essentially all organs, is independent, the user could play more than one note at time, in

contrast to most wind instruments which had a limited—if any—range of polyphony. Secondly, the hydraulis would have probably been significantly louder than other instruments.

Alongside these functional advantages, though, it also would have represented something of a technological marvel, both because it had the functional advantages, and also because of the mediated nature of the interface.³¹ So these seemingly small functional advantages of greater volume and polyphonic capacity came alongside momentous steps in the symbolic meaning of the technology and its interface in two respects. First, it was a model of a form of technology in which the source of power, force, or propulsion and the source of control had been separated. Secondly, it enabled a transformation of the one type of input into an altogether different type of output. So, as a magnification of a force and transformation of input to output, it represented a new kind of technology and a new kind of interface. Most importantly, it was a form that was more analogous to the verbal control of the ruler than the tool use of a farmer or craftsman. It was a herald of the age of a new relationship with tools and technologies.

We can see from the reports of Vesuvius that it was a treasured gift, a worthy kingly gift. The hydraulis could even be called the first digital instrument, perhaps even the first computer.³² It is digital not just in that it is played with the fingers, but because it allowed for a number of different settings controlled by a group of on and off positions—the ones and zeros of the classical world.

Another landmark early invention was the monochord, (see figure 2) an instrument with one string which Pythagoras utilized in his investigations of the relationship between mathematics and music in 582 B.C.E. The monochord was a conceptual relative of the much older Chinese Ke (see figure 1), although the lack of evidence of cross-cultural exchange at that stage suggests they were arrived at independently. With the monochord, the string was mounted on a sound box that had marks of tape at particular locations to indicate where to press one's fingers to hold down the string so as to change the pitch when plucked. In 100 C.E., Guido of Arezzo introduced a bridge that could be moved under the string that improved the consistency and accuracy of tone. More strings were added so that more complex pieces and melodies could be played. This principle of plucking or striking a 'pre-set' pitch became the basis for later adding keys.

These two classical instruments, the monochord and the hydraulis, provide the starting point for wind-based (organ) and string-based (harpsichord, pianoforte) keyboard instruments. The fact that a shared approach to physical interaction (pressing) occurred despite a range of different possible forms of sound generation across its history is one reason the keyboard has made such a good interface for the chameleon-like sound quality of modern electronic instruments. Also, because each press could create a note,

and each note required a string or a pipe or some such extension, the desire for polyphonic control led to instruments that were large and unwieldy.

2.2 The organ

The hydraulis turned out to be unstable, and required a high level of engineering and, by the fall of the Roman Empire, the technology had died out. Bellow-based pipe organ technology was developed, though, and although it originally was used for secular functions, around 900 CE it became a church instrument. Scholars typically ascribe this acceptance as stemming from Benedictine influence, and a corresponding shift towards polyphony. It should be emphasized that the physical and documentary record on organ history is extremely thin:

Rarely in the history of music does conjecture masquerade more confidently as fact than in the two chief questions concerning organs during this period: firstly, what kind of organ is indicated by such-and-such a source? And secondly, what was this organ used for?³³

It also is unclear from the historical record when precisely the modern form of the keyboard was invented. Apparently the earliest examples had only the equivalent of the white keys, and gradually the flats were added (see figures 4 and 13).

We know that by around the 14th Century there were examples of organs with keyboards in a relatively modern form, with seven long keys, and five short ones. In that period usually one set would be white and the other black, but the modern coloration had not yet become dominant.

Although we don't know who was responsible for the modern version of the keyboard (see figures 5-9), it is a brilliant design defined by three insights – the role of minimal asymmetry, tactile variation, and visual clarity. Minimal asymmetry is important because it retains the logic of the layout, without being so reductive as to be unplayable. Few people have perfect pitch, and were the keyboard completely asymmetric, you would have no way of knowing which key you were playing save counting from the edge. Furthermore, the asymmetry of two black keys and then three of course tracks with the most important musical relationship, that of the octave. Essentially, as an interface, the keyboard is modular but regular, and this is a source of its success on so many kinds of instruments. The short high accidental keys and long low natural keys create a tactile variation that is important for the hand to get to know the interface vis-à-vis muscle memory. Additionally, the visual clarity, simplicity, and geometry of the interface make it iconic, an interface that has organized, perhaps even domesticated the natural world.³⁴

Organs came to play a more and more culturally significant role with innovations around cathedral design taking place – cathedrals are in a sense the world’s largest acoustic musical instruments, and much could be said about the relationship between Western notions of the sacred, civil society, and music as ritual in the context of the development of the pipe organ as a central component of church architecture and worship (see figure 14). Arthur Loesser’s seminal book *Men, Women, and Pianos* is suggestive in this regard:

The instrument most suitable for artificial God-praising was the organ. It could sound both grand and intricate, like the Lord’s own works. Moreover, the organists’ hands did not, by vulgar muscular effort, themselves make the sounds they evoked; for his fingers merely released the valves that permitted great numbers of air columns, mechanically and menially produced elsewhere, to pass through the pipes at his will and discretion. He was not a mere player, subject to the limitations of a human body, but rather a supernatural operator, a commander and disposer of a thousand interacting sounds, a special image of the Lord himself. His right hand on one manual, his left on another, his feet busy on the pedal keys, he would often play a so-called “trio”; three clearly drawn melodic lines, independent, congruous, and rigorously separated; and if we wish to borrow the vocabulary of Leibniz, the age’s most representative philosopher, we would call them three windowless monads building the best of all possible worlds by pre-established harmony.

I quote Loesser at length not only because of his delightful prose and imaginative vision, but because the relation of an organist to an organ is very different from that of a pianist to a piano. The keyboard, as an interface, however, has merely been a way of controlling a range of systems for sound production, and given that the modern keyboards, especially in the form of synthesizers (see figures 32-45, 62, 67) use a variety of external controls, I argue that they are the cultural heirs of the organ, and that it is in fact the pianoforte which provides a better starting point for a new approach to real-time expression, especially when it comes to thinking about the design language and material approach.

2.3 The harpsichord

Although the direction of causality between musical instrumentation and the development of particular styles is difficult to establish, one could argue that keyboard instruments emerged to fit the harmonic and contrapuntal demands of early Western music, or specifically, to allow a musician to play multiple notes at the same time. If we trace their development as an example of increased function derived from structural variation, we begin with various stringed instruments like harps and lutes on the one hand, and wind instruments like flutes and horns on the other. The string instruments usually had multiple strings, and in the case of lutes, the tuning of the strings could be altered with one hand while they were strummed with another. With such an arrangement,

it is difficult to play more than four or five notes at once, and in particular it is almost impossible to achieve a counterpoint with a line in the bass and a line in the treble at the same time, because each note, or set of notes, requires two hands, one to pluck, and one to tune.

The harp, in particular the development of larger multi-scale harps, allowed a musician to play separate notes with each hand, thus providing a limited solution to the problem. But the proximity of a set of identical looking strings, and the layout that made plucking with each hand possible, made the playing less visually intuitive. It was difficult to achieve a high level of precise polyphonic expression, especially contrapuntal or complex harmonic expression. The technical, or at least deeper, reason for this difficulty lay in the lack of tactile reference points. In other words, with an array of strings that feel similar if not the same, the only clues the musician has to orient herself on the instrument lie in arm position and in the relative distance from the last note played.

Harp had advantages and disadvantages relative to lutes. Long arpeggios and certain kinds of chord based harmonic arrangements became easier and contributed to the harp's characteristic style, but the capacity to bend the pitch of the notes and control subtle intonational variation was lost.

The clavichord was developed in part to provide a practice instrument for organists, since the organs at the time had become extremely large, expensive to build and difficult to maintain. Structurally, though, the family of the clavichord, virginal, spinet and harpsichord (see figures 6-9, 11) built on the successes of the harp, but further allowed for greater and easier control of counterpoint and chordal variation. It was also the first, crucial step towards the interface we now call the piano keyboard. One thing it lost, particularly with the harpsichord, was the volume of an instrument like an organ, since the sound was created by the plucking of a string.

2.4 The pianoforte

The pianoforte (see figures 16-17) introduced one major innovation from whence it received its name – the capacity to precisely modulate the volume of the note in proportion to the force with which one struck the keys. This innovation came from the introduction of the hammer, and an extremely refined action or striking and releasing mechanism that enabled dynamic striking and sustain as opposed to plucking the strings. Musically speaking, it created an instrument of an entirely new level of control and sensitivity. It remains to this day one of the most powerfully polyphonic instruments, and is still the favoured interface for composers, since it allows for not only complex contrapuntal and harmonic expression and experimentation, but also the visualization of musical progression in a way that other instruments and interfaces do not.

The piano is an example of a mediated, but nevertheless analogous, interface: the touch of the key and the hammer hitting the string are mediated by a mechanism, but the two are closely allied since the way one presses the key is similar to the way the hammer hits the string. It was a machine, in a sense that was completely human sounding.

Logical yet sensitive, rational yet expressive, comprehensive yet inexhaustible, the piano was the physical expression of the ideals of the Enlightenment. The virtuoso sitting at the piano became an enduring image of the creative human genius, where the technology and the style of the interface played an important role in the power of that image.

Like the cithara in antiquity and the lute during the Renaissance, the piano is today our most important musical instrument. We could not imagine our musical life without it.³⁵

Just as the flourishing of new forms of creative musical expression in the Twentieth Century were inextricably linked to the development of electronic instruments, the invention of the piano took place at (or perhaps in part presaged) the height of classical creativity. Musical geniuses apparently expressed their insecurities vis-à-vis the skill with which their opponents had mastered the new language of the day:

When they first played the new piano, the last of the harpsichordists for a long while retained their old technique. Beethoven, hearing Mozart, said to Czerny that Mozart had a jerky touch, without legato, the touch of a harpsichordist.³⁶

Over time, though, the superior sensitivity of the pianoforte completely won out. Its dynamic range and expressiveness has made it into one of the most popular and culturally important instruments of all time. In *Piano Roles*, for example, James Parakilas argues that the piano functions as a kind of cultural glue between a wide range of different social and musical activities.

The piano has served as a cultural go-between because it is a particularly adaptable instrument...With a single set of strings, it evokes the harmony of a choir, the textural richness of an orchestra, and the rhythmic impetus of a dance band—a range of impressions that a pipe organ can hardly match with a roomful of pipes. Like a movie project, the piano envelops an audience in its illusion. Played by itself, it puts whole worlds of musical sound at the fingertips of one player. Joining other instruments or voices, it supplies whatever they need to make their illusion complete.³⁷

He examines the many roles the piano played in social history, from a tool for education to a sign of status, and yet the historical meanings of the piano have radically changed over the last 60 years with the introduction of electronic music. The grand piano,

especially as a physical object, now signifies the old, the traditional, the wealthy, and the conservative. It may still sit at the center of the orchestra, but the orchestra now lives at the periphery of our cultural imagination and musical landscape. Even the keyboard, the piano's contemporary heir, is a sideshow to the guitar in most popular music, and now is moving further aside to DJ tools and even laptops.

*When a tree falls in a lonely forest, and no animal is near by to hear it, does it make a sound?*³⁸

—Charles Riborg Mann and George Ransom Twiss, 1910

3.1 Recording as the abstract continuous

The perception and creation of sound is conditioned by the historical, social and cultural context in which a given person's senses are developed. Nonetheless, until about 150 years ago, sound was immediate: it couldn't be captured, bottled, transferred, or, strictly speaking, repeated. And then suddenly a number of technologies developed that radically changed the ways that we could interact with sound.

The rise of technologies that enabled sound production without corresponding perceptible sound generation events took place only in the last 150 years, and the rise of methods for creating music and sound that did not depend on muscular/hand skills has taken place primarily in the last 60.

This was the introduction of abstraction in music making, a world that had previously been entirely immediate. In the case of the visual arts, the process of painting, for example, was already abstract and non-immediate. Indeed, in painting, the challenge was creating the illusion of the immediate through abstract means. There was no technological barrier to creating a Mondrian in the Middle Ages; it was simply a question of establishing the conceptual framework to enable the ends to more closely relate to the means. In the case of music, though, abstraction was technologically impossible, and went against the grain of the immediacy that was required in all music creation.

It was only with the advent of recorded music, as well as things like tape and electronic music as a method of musical creation that the terrain of music began to undergo a fundamental shift. Before these technologies emerged, the only thing that could create musical sound was physical activity – real-time physical movement of muscles in relation to the voice or a sound-producing instrument. These technologies meant that suddenly the pressing of a button could create a sound which was disconnected from a semantically corresponding gesture. Depending on the settings of a given machine, the same movement, the same button, could create many different sounds. In these technologies, the one-to-one relationship between characteristic of physical movements – including the precise location, force of touch, and the particular timbral quality of sound – was dissolved.

The implications of this divorce between real-time physical expression and the planning and construction of a time-based medium outside of the timeline of its creation have been revolutionary. It was a greater change, in the domain of sound, at least, than even the invention of writing, since the written word doesn't require a particular playback in speech in the way that recorded sound necessitates. This playing back of a moment of time means that the two activities of creation and listening have a fundamentally different relationship to time. Suddenly options abound, and intimacy becomes perhaps harder to

achieve.

These inventions—recorded music, the telephone, the radio, amplification, electronic music, and digital music—had a major impact on the social meaning and value of music and more broadly on our experience of modernity, probably only second to technologies associated with capturing moving images. And in one sense, in the perfection of our experience of the abstraction of physical sense experience, sound surpasses even the visual.

Reproduction plays a fundamental role in our experience of modernity. In *The Work of Art in the Age of Mechanical Production*, Benjamin writes that, “Even the most perfect reproduction of a work of art is lacking in one element: its presence in time and space, its unique existence at the place it happens to be.”³⁹ And the emergence of technologies associated with the replication and amplification of sound more perfectly realizes the promise and problems of modernity than replication in the context of any other sensation. This is because sound reproduction is not only excellent but also complete.

In the visual field, visual reproduction—for example in the context of film—is always fundamentally different from three-dimensional interaction and engagement. This isn’t true in the context of sound. When you hear someone in another room speaking, you have no way of knowing whether it is a person or someone on the radio, whereas for now, until holograms progress a very long way, it is difficult to mistake a moving image for reality. This fundamental characteristic of quality and holism with respect to the reproduction of sound means that we more fully feel the abstraction of sound from the physical than we do with any other medium, and this abstraction is a source of both the divinity and the alienation we feel as a result of modernity. We feel divinity because we feel we can abstract things from their source – physical events are the source of sound in all pre-modern human experience, but in a modern context and with modern technologies, we have extracted sound from that source, and can control and produce sound in entirely new ways.

And here we also see a new connection emerge between our four orienting ideas of discreteness, continuity, abstraction and immediacy. Before the invention of recording and reproduction technologies, the discrete and continuous were both characteristics of immediacy. There simply was no real possibility of time-based abstraction in the production of sound. Early recordings, though, did have a kind of continuous character, different from the character of a continuous but immediate note, but continuous nonetheless, in the sense that there was a necessary singularity and monadic quality to a given audio track. Of course with multi-track recording a new relationship between the discrete part and the continuous whole is established, but the fact that early recordings had a continuous and monadic character to them is worth noting, especially as a contrast

to the style of human interaction and interface that they utilized.

Excellent books have been written on the history of these technologies, and on the more specific rise of electronic music, synthesis, and more.⁴⁰ The present work provides a way of thinking about these very large questions through a focused exploration of the creation of a new tool for sound and music creation, and thus my purpose here is not to provide any potted histories, but rather to focus on a number of specific issues which pertain directly to the context of the invention and the decisions involved in the design.

3.2 Abstract interface as discrete

As new technologies of synthesis and sound creation emerged, one of the big questions was how to control them. Two new input methods and corresponding interfaces suddenly took on huge importance where previously they had played a much smaller role in the history of music. The first was buttons and switches, and the second was dials and faders.

Although trumpet or clarinet keys and flute holes have a button like quality, they are not simple switches with an absolute on/off position. The speed and extent to which these are depressed or covered affects the acoustic sound created.⁴¹ With electronic systems, suddenly on/off and other binary designations become an important part of the design, and buttons or switches are the easiest way to organize such interactions. Similarly, in electronic instruments, one suddenly has a whole range of possible parameters to work with. Each one has a designated range, and dial or fader/slider is one of the most efficient ways of controlling such a range.

Buttons and dials have no natural or necessary organisation. If you have more than one of each, buttons and knobs need to be labelled. Buttons and dials take a whole hand to depress or turn. They also typically require visual confirmation in ways that most acoustic instrumental interfaces do not. This is particularly true of dials, because one has to have some awareness of the state it is in before adjusting it. The use of half of ones hands, and more than half of ones total attention including visual awareness means that buttons and dials don't fit entirely easily into real-time performance.

Because they have no natural organisation, devices with lots of buttons and dials become more identified as products than instrument categories. A Fender Stratocaster and a Flamenco guitar are both guitars, and are very different, but anyone who can play one can immediately play the other. Two electronic instruments might both be drum machines, or synths, or keyboards, but knowing one item from a given category doesn't imply relative mastery of others. Each device has to be independently learned. Some conventions are strong, like having a pitch and mod wheel to the left of a keyboard.

The semantic implications of buttons and knobs are very different from the implications of most acoustic musical instruments—they give more the impression of the complex technological interface of an airplane cockpit than the impression of a virtuosic tool like a brush or surgeon’s scalpel. And with the rise of computers and consumer electronics, buttons and dials became a more and more domesticated contemporary language of everyday use. This contrasts with the more bodily, sensuous implications of a taut string or pressing an instrument against one’s lips.

Buttons and dials also relate to two of our fundamental interpretative categories, the discrete and the continuous, in obvious ways. Buttons clearly give one an absolutely discrete option between on and off, and dials give a continuous range which can be altered in real-time. Having said that, dials enable a single parameter to be altered independently at a time, which can give great precise control, but it is difficult to create the kind of complex set of parametric changes involved in the timbral shaping in a human voice or other instruments as a kind of ‘sonic gesture.’

Abstract *interface* finds an easier friend in discreteness than it does in continuity. Abstraction means layering, richness and control, where immediacy brings with it the associations of expression, and the analogy to the human voice. Given that abstraction and immediacy are not mutually exclusive, a few key categories of musical products emerged, like synths, sequencers, drum machines, workstations that utilised elements of both.⁴²

Keyboards provided an obvious way of controlling new electronic and then digital ways of creating sound.⁴³ One of the most important steps taken by Robert Moog, and one of the reasons he emerged, over Don Buchla, as the premier innovator of synthesis was his use of the keyboard. He simply used the keyboard as a way of controlling pitch, but in so doing gave the synth a completely different kind of identity.

Initially keyboards as an input device were capable of more subtlety than the electronic systems they were controlling, and the synthesizer keyboard was much more strongly related to the keyboard interface of an organ than the sensitive and responsive action of the keyboard on an acoustic piano. Nevertheless, by the 70s and 80s a great deal of the polyphonic expression of the piano was possible with synthesis, and of course the added benefits were immense, whether through the input capacity of an aftertouch enabled keyboard like a CS-80 (see figure 41), or through the new timbral palette introduced by the DX-7 (see figure 43). To some extent even today, the electronic/digital use of a keyboard cannot compete with the acoustic piano in its hallmarks of subtlety of velocity and overtone expression. Having said that, recently the processing capacities of these systems increased and surpassed the information-richness and dynamic shaping capacity

of the keyboard as an input device. And Moog himself understood better than many that the traditional keyboard was not an ideal input device for synthesis-based instruments.⁴⁴

One limiting factor was MIDI. MIDI is a software protocol that emerged directly as a reflection of a design consensus about electronic instruments that had emerged in the early 80s. MIDI has had the effect of then freezing the development of the design choices in these areas, because the more MIDI became entrenched, the higher the cost of trying to create new instruments that broke from its structure.

Electronic music historian Tom Rhea maintains that the initial idea of simply connecting keyboard instruments to one another was “mundane, predicated on equal temperament, and has shackled the development of wind and other continuous controllers” (personal interview, 1989). Others have criticized the limitations of the serial interface for high-speed transmission of digital information. In fairness to the developers of the specification, however, the synthesizer field has been dominated, almost from the beginning, by keyboard instruments.⁴⁵

Meanwhile the rise of software-based technologies had major implications for input methods and interfaces. With the rise of fast, affordable computers, it was inevitable that software would replicate the functionality of many hardware devices and in some cases replace them. In particular, GUIs improved the scope of manipulation for highly abstract workflows within workstations, and allowed for much larger architectures of functional options within a given framework. Having said that, the intuitiveness of the physical was lost, and many software interfaces were designed (and are still designed) with a skeuomorphism replicating a much smaller version of hardware interfaces with many dials and sliders. Thus the software design is an abstraction of an abstraction, where the limits of designing a hardware control device has now limited the imagination of GUI designers. With the move to software, the already difficult to learn interfaces—each individual product with a separate layout and set of features that have to be learned—have only become more byzantine.

3.3 From the immediate to the abstract

This leads us to our present situation. The contrast between continuity and discreteness in sound is deep and native to all music. The distinction between real-time and abstract approaches to music making only came into being 150 years ago and yet it captures an important challenge of our modern condition.

Sound production does not require or involve the sort of labor that we usually associate with physicality, so in a post-Platonic intellectual and cultural context in which rationality is the highest expression of humanity, our ability to move from physicality to abstraction, is

a distillation of our humanity and in a sense a statement of divinity, as we abandon the baseness of the physical. Having said that, this de-physicalizing is undeniably also a source of alienation, because once we have abstracted sound from its sources – once we find we have made our bodies and our corresponding muscle memories redundant, we end up losing a great deal of the particularity and personality that comes with being human. In musical terms, we are left with an unchanging and hard beat, inorganic and strangely inhuman. The way that these trends impact the content, style and feel of music, and in turn express the spirit and experiential qualia of our time, is a fundamental case of reciprocity between the formal conditions of possibility and the content of the actual.

The technological, social, and cultural aspects of this history are all entwined, and a more synthetic experience is only possible with more synthetic tools which not only go beyond the divinization and alienation of modernity, but also the implicit acquiescence to the synthetic as unattainable in much post-modern thinking. These tools must reintegrate the physical, and the brute facts of our embodiment, into our capacity for abstraction. So long as our tools condemn us to a choice between these two fundamental aspects of our being, we will find ourselves divided and dissatisfied.

3.4 The *virtuoso* and the *technologist*

In order to have some hope of reintegration, we have to understand how we imagine and perform these two aspects of ourselves. What do they look or feel like or mean in tangible terms? It isn't just a question of inventing new technologies that gives us more choices; these technologies have to be designed and developed into products that help us to understand our subject position and give us opportunities to evolve. The design of any object tells us about its user, and how she sees herself or wants to be seen. In the case of musical instruments, the design of the object is even more strongly defined by how it reflects on the musician given that the instrument is used in a moment of heightened performance.

In the same way that the voice and hand provide the archetypal tools of music, and melody and rhythm are the archetypal characteristics of music, there are (at least) two archetypal images of the musician: the *virtuoso* and the *technologist*. Of course these archetypes are culturally and historically changing, but they nevertheless illustrate an important point with respect to the physical design language of given instruments.

The virtuoso is a performer of physical skill, someone who can create complexity from simplicity, and transform her own voice, or bodily movements in expressive sound. The virtuoso is a kind of athlete, a natural, who enters the present in such a complete way that she brings the audience with her.

Where the virtuoso extends, the technologist transforms. The virtuoso has found a way to extend her voice, to carry it further through a new physical practice, where the technologist disrupts and transforms the landscape of the possible. Buttons, sliders, and dials are the tools of the archetypal technologist. The technologist is the organist, the keyboardist, the synth player, the studio creator, the DJ. The technologist is more the nerd; perhaps without the natural athletic ability of the virtuoso, a more disembodied intelligence—an abstractionist.

Obviously, today many performers and DJs use laptops to create music and the fact that they use the same devices to write emails and compose music doesn't inhibit their creative processes. Seeing someone on stage dancing in front of his or her own laptop is different from seeing a performer play a grand piano; here again the medium is the message. In the first instance, dancing in front of one's laptop carries with it a set of implications about the celebration of the narcissistic individual, about connecting through technology, and so forth. Performing at a grand piano carries with it implications about class, a connection with a traditional history, and a form of individualism defined in another age.

Evidence for these archetypes is present across many studies of performance and gesture in contemporary music production. Gareth Paine, for example, observes the characteristics of the virtuoso in his *Towards Unified Design Guidelines for New Interfaces for Musical Expression*:

A direct relationship is established between the physical gesture, the nature of the stimuli and the perceived outcome. The resulting awareness is multifaceted and has been at the core of musical performance for centuries. These levels of engagement extend to distributed cognition — that is, a product of the body as a whole and not simply the brain—and as such allow musicians to enjoy an embodied relationship with their instruments (where the instrument and performer may appear to dissolve in one entity) a relationship that is communicated to the audience through performance gestures.⁴⁶

He then distinguishes another contemporary approach to music making which resonates strongly with the archetype of the technologist:

Computer-based music, however, heralded the dislocation of the excitation, sonification mechanism, dissolving the embodied relationship the musician previously enjoyed with his or her instrument whilst simultaneously introducing a broad range of possibilities that defy the limits of the human body...⁴⁷

These archetypes of the virtuoso and the technologist are not meant as absolute or non-overlapping. Consider the DJ, the ultimate musical technologist, who by scratching

records, did, for a time, reclaim something of the virtuoso: the rebellion implied by scratching records is not only the potential for damage or the dislocation of sound – it is the repurposing of an abstract technology into an immediate one. It is taking a tool for music in an age of mechanical reproduction, really the tool par excellence that stands in particular for *mechanical* reproduction, and turning it back into a human, real-time expressive instrument, and yet one that includes reproduction within its scope. This makes it not just a return to the thesis of live acoustic music from the antithesis of recorded electronic music – it is truly a synthesis.

Perhaps this proves that these archetypes no longer have, or should have any purchase on our contemporary situation. Maybe the virtuoso is an image of the pre-modern, and the technologist the modern, and we now live in a post-modern world where the distinction no longer applies. Or maybe our technologies need to evolve a little further before the image projected by an immediate or abstract performance is one and the same thing.

3.5 Contemporary explorations in discrete/continuous musical instruments

A number of contemporary interface explore this terrain. Sometimes called broadly digital musical instruments, or more specifically polyphonic multidimensional music controllers, they each begin with slightly different design specifications and objectives and thus are difficult to directly compare. Nevertheless, a partial list of relevant controllers and interfaces which enable some degree of polyphonic multidimensional capability and thus contribute to shrinking the gap between the abstract and the immediate, the technologist and the virtuoso would including the following: the Haken Continuum, the Eigen Labs' Eigenharp, the forthcoming LinnDesign Linstrument, the Endeavour Evo keyboard, KMI's QuNexus and QuNeo, David Wessel's slabs, Madrona Labs' Soundplane, Mogeas, Hyperkeys, Andrew MacPherson's TouchKeys, Nu Design's Alphasphere and of course there are many more.

Indeed, there are too many on this list and beyond to comprehensively discuss each one. In the following chapters I discuss those that relate most closely to the Seaboard where applicable: here I will simply contrast two to demonstrate that even in the context of polyphonic multidimensional controllers two ends of the spectrum from technologist to virtuoso can be represented, but this doesn't necessarily bring about a better synthesis on either side.

The Soundplane was invented by Randy Jones, and is described on Madrona Labs' website as follows:

The Soundplane Model A is a computer music controller with the sensitivity and feel of an acoustic instrument. It detects a wide range of touches on its walnut playing surface, from a light tickle to a very firm press. Unlike a MIDI keyboard, which typically sends out just one velocity value at the start of a note, the Soundplane communicates three dimensions of information, x, y and pressure, over the entire duration of every touch. As a synthesis, this lets you replace a triggered envelope with an intimate connection and breathe life into each note.⁴⁸

It is a beautifully simple controller that simply offers a flat surface. The simplicity, not to mention the finish, of the Soundplane does make it feel like an acoustic instrument. Having said that, it lacks a clear repertoire and is thus reasonably difficult to develop a high level of skills.

By contrast, the Eigenharp, invented by John Lambert, offers a plethora of complex control options, from a set of highly sensitive keys, a slider, a breath controller, LED for sequencing and more. The Eigenharp is described on the Eigen Labs website in ambitious terms:

The most expressive electronic instrument ever made... Designed from first principles, the Eigenharp brings truly expressive musical performance to every musician. Its astonishing versatility, sensitivity and ease of use make it the most rewarding instrument you will ever play. Available in three models - the Alpha, Tau and Pico. The Eigenharp is the ultimate instrument for musical performance.⁴⁹

Where the Soundplane is simple and connects strongly to the tradition of acoustic instruments, the Eigenharp brings a more strongly technological aesthetic not only to its industrial design but also its design aspirations. Both rely on advanced sensing technologies and provide a wide scope for various kinds of customization, but neither is particularly intuitive to use. The problem of evolving the terms of musical instrument design is extremely demanding because there are so many natural constraints and unavoidable reference points that one faces with every key choice and necessary compromise. Nevertheless, pioneers like Jones and Lambert have blazed important trails in creating instruments that are incredibly sensitive and in many ways deeply refined, and their work, and the work of all the inventors and designers in this space has helped to inform the current practice based research.

Part 2. Practice

Invention, development, design, and refinement of the Seaboard

...[T]he inventor, to be successful, needs to combine in himself a great many diverse qualities. In the first place, he must be in love with invention, and either have faith in its value, or at least an abiding delight in its game.⁵⁰

— H Stafford Hatfield, c.1930

4.1 Beginnings

Creativity is often closely associated with the visual. Words like 'imagination,' and 'creative vision' reinforce the importance of sight in how we think about the new. But imagination is the mind's ability to invent and create across all senses and forms of conception.

I remember sitting at the piano in the cafe of the RCA, playing a C blues, with my eyes closed. I was humming along, probably not too tunefully, as I'm not a great singer. It was a slow tune, and when I reached the final note in the melodic line, I started to gently rock my wrist from side to side, pivoting from the tip of my finger holding down a key. The tone of the piano remained constant, of course, but my voice introduced a vibrato to the note, in sync with the motion of my hand. It wasn't an idea so much as a set of intuitions about touch and sound that occurred to my voice and hands at the same time. I'd reach a familiar slide from an E-flat to and E, implying the minor third and the resolving to the major third, and yet where the piano would play two notes, my voice would sing out a single pitch-bending slur. The gestures of my hands and the sound of my voice had conspired to propose a new approach to the keyboard - all I had to do was invent and build a new instrument that would connect touch and sound in this way.

It turned out that building a new bridge between the input of touch and the output of sound would become a complex process of invention, development, design, and refinement. I certainly wasn't the first pianist to aspire toward vibrato; I just may have been the first to solve the problem through physical invention. Indeed, this passage from *A Romance on Three Legs: Glenn Gould's obsessive Quest for the Perfect Piano* suggests that the aspiration wasn't just a passing fancy, either:

Gould was convinced that he needed wider gaps between the white keys so that he could move a key laterally while it was depressed, like a string player creating vibrato. Film clips of Gould playing show him trying to do precisely that. Although the mechanics of the piano—any piano—make vibrato technically impossible to achieve, he was certain it could be done. To his delight he decided there was more space between CD 174's keys than usual, thus enabling him to create a vibrato effect. The only explanation for this, Gould insisted, was that 174 must have been wider than the standard concert grand. Steinway's technicians refused to believe this could be the case. After all, in their dimensions Steinways were built to be as uniform as box cars. At Gould's suggestions, they measured the piano, only to discover it was wider by three-eighths of an inch.⁵¹

Where Gould's obsession had been searching for the perfect piano, mine was creating a new imagining of the instrument. It took years of iteration, testing and analysis to begin to reach a satisfying result, and ultimately all the work was grist for the mill of decision-

making. If one knew everything about the final goal and desired results, the actual process of creating a solution would be a tiny subset of the work of development and design. Research involves the development of new knowledge, but in the case of design, often this is practical knowledge that gives the designer just enough information to make decisions and take next steps. In this chapter, I recount the first steps taken in this effort to create a new kind of electronic musical instrument that built on the expressiveness, versatility, and familiarity of the piano keyboard.

4.2 Negative capability

After conceiving of the concept of a more integrated and intuitive approach to pitch bend, I began by taking apart the keys and action of a piano. My intention was to introduce a secondary axis of motion into each mechanical key. As mentioned above, I was committed to the idea that pitch bend would only be intuitive if it was based on a side-to-side motion with the bending being mapped with bass in the left, and treble in the right. My first idea for how to do this (captured in momentary sketch in figure 83) was to carve out the inside of each key and introduce an additional axis of motion, such that when a C, for example was depressed, it could then be pulled to the right or left.

I rejected this idea after briefly prototyping it. Although pitch bend would be mapped to movement towards the left and right, and thus it would have been an improvement on the pitch wheel, the amount of the bend would be a function of the angle of the key, rather than ultimate position.

In this arrangement, one would have to choose between three poor options with respect to the amount of pitch bend associated with pushing a key to its maximum angle of rotation. The first option would be to make each key capable of only a half step of pitch bend. This might have made vibrato possible, but it wouldn't have allowed larger, more expressive bends. The second option would have been to make each key capable of bending more than a half step, but this would have led to an unintuitive result, because you could play, for example, a C major chord, and then bend the E up to a B, and then although the finger playing the G would be higher than the finger playing the E, it would be playing a lower note, something that never can happen in the course of keyboard playing. The third option would be to make the angle reassignable, but that would make it more or less impossible to attain virtuosic capacity because the relation between muscular feedback and aural feedback would become unstable, as it is with the pitch wheel.⁵²

In addition to rejecting this approach, the thought experiment helped to clarify that an adequate solution had to: (a) enable pitch bend through left to right movement (b) have each current pitch be a function of absolute left to right motion, (c) enable very precise

bends both for small intervals, such as vibratos, and larger glissandos, and (d) be capable of being mastered through practice by ensuring a stable relationship between muscular and aural feedback. I came to the conclusion, on the basis of these criteria, that building a continuous function into a mechanical keyboard would not enable a sufficiently intuitive solution and so I began to explore non-mechanical approaches.

As it turns out, around the same I was exploring this deconstruction of the piano, another instrument called Hyperkeys (figure 73-77) was being developed that took a similar approach to the one I had rejected, albeit with an axis of movement up and down, rather than side to side. Although Hyperkeys is subject to all the problems stated above, and an additional one since it lacks side-to-side movement, it can be played very expressively (see video 69).

A more general survey of other instruments that combine a traditional mechanical keyboard form and function with continuous control include aftertouch keyboards, the Evo keyboard, and TouchKeys. With aftertouch keyboards (see figure 41 of a CS80) one strikes a key and then once one reaches the end of the throw of the key, one can press down a little harder and the keyboard senses the level of pressure. 'After' touch though is an apt name, since the initial strike of the key and secondary press are not a single action. Having said that, applying additional downward pressure after having struck a key on a pitch so gentle that it feels more or less like one is pressing downward is largely intuitive, and aftertouch keyboards have met with significant success. The Evo keyboard and Touchkeys (figures 73-77) both provide a degree of touch sensitivity in the surface of the keyboard. With the Evo keyboard, the keys are touch sensitive in the y axis, meaning that after one has pressed a key one can glide along the key up and down to control an additional parameter, creating a similar effect to Hyperkeys with a less mechanical solution. Perhaps because of the shape of the sensors used, though, the spacing of the keys was unlike that of a standard keyboard, and thus I personally found it difficult to play. Touchkeys, on the other hand, plays very well as a keyboard and can be retrofitted to standard keyboards. Touchkeys offers a set of piano key shaped PCBs that sit on top of the standard keys and enable touch sensitivity in the x and y axis. I believe this is the strongest solution of its kind, and with the exception of the feeling of the texture of the keys, something that can be refined through iteration, a great playing experience.⁵³

4.3 Inventing the Seaboard

Having thus rejected mechanical approaches to augmenting the keyboard, I returned, so to speak, to the drawing board. My next approach was to focus on a flat surface with a similar layout to the piano that would enable one to play pitches in given locations, and then smoothly glide between these pitches along the top of the surface. In this space

there are two main types of solutions - touch screen solutions in the form of apps for tablets (see figure 59), and new instruments with continuous flat surfaces, such as the Haken Continuum. The Continuum is the most important instrument in this space, and one of the closest relatives of the Seaboards, so it bears detailed discussion.

The Continuum (figures 49-55) provides a black and red fabric surface in a similar layout to the keyboard. It is highly sensitive to the lightest of touches, and provides a high-resolution to continuously bend the pitch from left to right, and is also sensitive to movement along the y-axis and to pressure. It is an extremely expressive instrument with real depth of possibility and a devoted community of musicians. Given that one receives no muscular feedback associated with the location of the strike, unlike with a piano where one can immediately make muscular micro-corrections due to feeling key edges and the like, it is difficult to play it in a keyboard-like way. Experts such as Ed Egan, created of the Continuum's EganMatrix synth and longtime collaborator of Lippold Haken, has reported that it is difficult to play the continuum without adopting some level of vibrato technique, where a small amount of movement is used to help find the notes. Whilst polyphonic pitchbend is possible, accurate polyphonic chordal playing, a hallmark of most keyboard technique, is difficult or impossible to achieve.

Conceptually, one can imagine a spectrum from solutions that are closer to the keyboard and enable effective discrete playing, and other solutions that enable continuous playing. The mechanical solutions are at one end of the spectrum, and these surface solutions at the other, where they are great for continuous playing, but more difficult to use for polyphonic discrete playing. With this in mind, I continued to explore, since I wanted to find a solution which would enable as many as possible of the virtues of the mechanical keyboard as well as the expressive capabilities of instruments like the Continuum.

Having rejected the mechanical and flat, I began to look for a solution that would encompass elements of both. I sketched the piano again and again from various angles, and at one point when drawing a front view, followed my pencil as I began softening the edges of the keys to create a more continuous but nevertheless non-flat surface (figure 78).

The discrete keys of the piano were thus physically re-imagined as a single, continuous, non-flat surface, where the relatively raised and recessed areas of the surface correspond with the centers of the white and black keys. The peaks of the waves would produce, when pressed, musical notes corresponding to the notes of a standard musical keyboard.

The idea was that the Seaboard would be able, to a significant extent, to mimic a conventional keyboard in its operation with respect to enabling the musician to polyphonically play a set of accurate discrete outputs and intuitively move from that

gesture to one that bends the pitch. For example, by pressing on one of the 'peaks' or 'crests' and vibrating a finger, an oscillating signature can be generated by the sensors, which would be interpreted by the processor as a vibrato.

This became the core idea of the Seaboard—to take the basic design layout of the piano keyboard and refashion it with a new surface shape and a new material.

Every craft and every investigation, and likewise every action and decision, seems to aim at some good; hence the good has been well described as that at which everything aims. However, there is an apparent difference among the ends aimed at. For the end is sometimes an activity, sometimes a product beyond that activity; and when there is an end beyond the action, the product is by nature better than the activity.⁵⁴

—Aristotle, 384-322 B.C.

5.1 Methodological timing

A question always arises about the timing of presentation of methodology. When presented at the beginning of anything other than hard scientific experimentation, it gives the appearance of a too-neat fit between methods and practice. In any real practice of innovation, methods evolve as the practice does. On other hand, presenting methodology at the end of a body of work risks it seeming like an afterthought, and the reader may have less of an opportunity to reflect on how the articulated methodology intersects with the practice as he or she is reviewing and understanding the practice.

For these reasons, I've taken the decision to place this chapter on methodology near the middle – after enough background and context that we can wade into some of the more particular issues of methodology that were relevant for this particular practice, but before the main discussion of the design and development practice.

5.2 Means and ends

Methods are tools, means to a given an end. The right tool depends on the particular end. Aristotle's reflection above is helpful to consider, as even with respect to the question asked in this research practice, the locus of emphasis could be in one of three places. Firstly, one could judge the Seaboard as a product, focusing the frame closely on the product itself. Secondly, one could focus on the activity of playing the Seaboard as an experience. Thirdly, one could emphasize the product of that activity, the music itself. Unlike Aristotle, who claims that the final product is the most important end, I have taken a more holistic approach to understanding and documenting the whole chain from the Seaboard, to the experience of playing it, to the music produced through that experience.

This approach has informed the choice of media and emphasis in Appendix A-C. Appendix A deals with figures which primarily capture the Seaboard as an object in relation to other objects that have come before. Appendix B shows videos of musicians playing the Seaboard, communicating something of the real-time experience of playing the Seaboard. And finally, Appendix C presents the product of that experience in isolation in audio. And hopefully this text helps to tie all the elements together.

5.3 Systematic and practical methodology

Inventing, developing, designing and refining new musical instruments is an extremely complex set of heterogeneous processes and thus summarizing a single straightforward methodology for conducting and documenting this form of practice-based research is not easy.

First consider the challenges. Designing and prototyping the Seaboard to the point of successfully proving that a new synthesis between acoustic and digital technologies is possible requires significant coordination and integration of a range of disparate technical disciplines: concept design, interaction design, material science, product design, industrial design, mechanical engineering, design for manufacture, electronic engineering, embedded systems engineering, firmware and software engineering, software design, sound engineering, and sound design. And this doesn't include the disciplines involved in understanding and evaluating the meaning of the technical decisions.

Sergi Jorda captures this complexity well in '*Instruments and Players; some thoughts on digital lutherie*'

New digital instrument design...includes highly technological areas (e.g. electronics and sensory technology, sound synthesis and processing techniques, computer programming...) human related disciplines (associated with psychology, physiology, ergonomics, and many human computer interaction components), plus all the possible connections between (e.g. mapping techniques...) and the most essential of all, music in all its possible slopes.⁵⁵

From a methodological point of view, this complexity of interdisciplinary terrain raises significant problems, since the demands of systematic and practical knowledge are widely divergent. Naturally, the design work as a whole does shed new light on a set of larger questions about music, instrumentation and interaction, but capturing the approach that led to the small insights and discoveries that made the complete work possible is more difficult. The most one can say broadly is that the method adopted in the course of this practice-based research has been to use a variety of design and development tools and strategies to support evidence-based decision making to test whether building such a bridge between touch and sound would be feasible, and if so how.

5.3 Dialogical and a dialectic methods and practice

Design involves a dialogical and dialectical interplay between conception, object, and experience. Richard Sennett provides a succinct and clear definition of the difference between the dialogical and the dialectic. On the dialectic:

...[T]he verbal play of opposites should gradually build up to a synthesis; dialectic starts in Aristotle's observation in the *Politics* that 'though we may use the same words, we cannot say we are speaking of the same things'; the aim is to come eventually to a common understanding.⁵⁶

In the case of the dialogical, on the other hand, he observes:

Though no shared agreements may be reached, through the process of exchange people may become more aware of their own view and expand their understanding of one another.⁵⁷

This dialogical process of listening to various points of view is crucial in the early stage of a design process—forcing a premature synthesis closes down new pathways and possibilities. But the dialectical is necessary too in the later stages of the process when only one decision can be made.

One has a conception, an experience, or encounters an object. A given idea, for example, leads to the conception of a new kind of object. One makes the objects and discovers problems and possibilities in the act of making. Once complete, the object can be experienced, and that leads to new conceptions. Sometimes these strands are dialectical in that they all can be resolved in a given direction. Sometimes the pure conception of how something should be, its material reality, and the subjective experiences it triggers all push in opposing directions. Perhaps the best sign of a healthy design process is one in which the dialectic translates into the dialogical naturally through the process of making, testing, and evaluating.

The often messy, non-linear, and surprising quality of creation creates a fundamental methodological tension. To the extent that the goal of research is knowledge per se, it is essential to properly isolate and control every variable. When the goal is the creation of a new experience, ultimately what matters is how all the variables act in conjunction.

And as a practical matter, it is not always possible to systematically isolate each variable and create a sufficient number of prototypes to prove the superiority of one solution over another. New prototypes sometimes must test multiple propositions at the same time, though it is often subjectively impossible to separate out the causal relationships that contribute to a particular form of behavior. For example, latency and the elastic quality of the elastomer are objectively two different issues. For a player, both create the feeling of sluggishness. This creates serious risks associated with developing multiple improvements on different fronts in parallel especially to the extent that the testing methodology is subjective. Over time, it has become necessary to take a more and more scientific approach to the development and refinement of the Seaboard. In the early stages of the process, each step forward was obvious enough that many could be taken at the same time, and intuitively confirmed without any doubts. It increasingly became necessary to conduct the development of new prototypes as clear controlled experiments driven by a well-articulated hypothesis and tested in multiple independent ways.

5.4 Methods by stage

Research can take many forms, and design research is particularly broad, since it takes place not only through reading texts, but also simply by playing close attention to the created objects we find ourselves constantly surrounded by. Certainly one aspect of interface design research is reading seminal books, but more important is the hard to quantify and footnote process of becoming more sensitive to ones' own user experiences.

Sometimes design projects need to be temporarily insulated from too much external input or they will become caught in a mood similar to what Harold Bloom coined "the anxiety of influence." In general, however, information is crucial to good decision-making.

As the whole process from start to finish has been divided into four phases (concept, design, technology, and production) and each has its own research element, it might be worth clarifying what is meant by 'concept research' per se.

Concept research refers to the fundamental background required to more fully understand, contextualize, and effectively develop a concept. For concept research and development to take place, a core concept needs to be present, and worth exploring (though, sometimes paradoxically until you conduct more research and development it is difficult to know the value of a kernel of an idea). It is a survey of the field or fields related to a given concept, looking at the history, the market, the high level approaches, issues and themes that come up in relation to the concept. Design research, on the other hand, often involves user scenarios, and a variety of more detailed, interaction-oriented information gathering techniques, where concept research begins with slightly broader strokes. This chapter focuses first on explaining the nature of the Seaboard concept and how it was developed, and then on supporting that concept with research into related devices and tools. Later in Chapter 6 the design language is considered in more depth.

5.5 Documentation methodology

Having developed a clear concept, the next challenge was to make the Seaboard a reality. The development has involved thousands of iterations, some whole-scale, others just on a given part or another, many of which were happening in parallel. For this reason, it is worth explaining the main chronology, components, and thematic issues at the outset and setting out how the narrative documentation will be organized. Chronologically, there have been six main prototyping stages:

Interface Concept Design: Seaboard 1

Interface Technology Development: Seaboard 2

Proof of Interface Concept: Seaboard 3
Product Concept Design and Development: LUTE Seaboards (4)
Proof of Product Concept: Seaboard PPP series prototypes (5)
Product: Seaboard GRAND Series products (6)

Please see *Appendix E. Seaboard Component Areas* for the comprehensive overview of the physical and logical components that guides the documentation strategy. The categorizations are imperfect, as an audio device will usually have physical and digital elements, and so forth. And note that not all of these items necessarily need be included within a Seaboard – in many cases at least a few of them will be external devices, but they all need to be considered in every design decision.

In addition to particular component areas in every Seaboard, there are a range of other ‘multi-component’ areas which inform the development at every stage arising from the relationship between multiple components. These include issues like the number/size of keywaves per Seaboard, the aesthetic design, the assembly process, the registration of the keys, issues associated with lifecycle/maintenance/servicing, practicalities of transportation, latency, minimum and maximum activation point (MMAP), pitch accuracy with respect to playability, interface/software integration, compatibility/workflow and so forth.

In the following chapters, the documentation is organized primarily according to the chronology of the prototype development. Within each stage, I first run through the relevant component area, and then through the thematic issues and discuss the progress made and lessons learned. This brings some of the clarity and order of hindsight without creating the impression of a falsely straight line from beginning to end.

The component area diagram is a good reminder of the main clusters that have to be considered in the design process, and their primary touch points. It doesn’t, of course, capture all the necessary connections and particular problems that arise between the different areas, but it is nearly sufficient to ensure that one can consider each of the parts in relation to the whole. I say ‘nearly’ because the real whole also involves a human being, and our human map of ‘component’ areas is far harder to draw. Nevertheless, the total interactive system requires a deep understanding of people—their sensory systems, cognitive latency, aesthetic associations and much more.

5.6 Evaluation methodology

In order to ascertain the extent to which the Seaboard will fulfill the objective of building on the well-known layout of the piano keyboard to create a new instrument that more fully enables both continuous and discrete approaches to music making in a way that provides

a satisfying result for performers, composers, and producers, it is crucial to articulate a clear evaluation methodology.

In the last few years anecdotal arguments and experiments in evaluating digital musical instruments (DMIs) have culminated in the beginning of more comprehensive approaches, especially as articulated by O'Modhrain in a key recent paper in *Computer Music Journal*.

O'Modhrain argues that:

...for the field of DMI design, a much broader definition of the term "evaluation" than that typically used in human-computer interaction (HCI) is required to reflect the fact that there are a number of stakeholders involved in the design and evaluation of DMIs. In addition to players and audiences, there are also composers, instrument builders, component manufacturers, and perhaps even customers. And each of these stakeholders may have a different concept of what is meant by "evaluation."⁵⁸

This wider and more systematic consideration of stakeholders enables Mondrian to articulate an evaluation matrix that takes a multiplicity of perspectives into account. He focuses on four types of stakeholders—audience members, performers, designers, and manufacturers—and assesses the methods each group uses, where applicable, to evaluate DMIs with respect to four main design goals: enjoyment, playability, robustness, and achievement of design specification.

Given that the stakeholder satisfaction of audience members, designers, and manufacturers is dependent on the satisfaction and engagement of performers, I treat performer evaluation as primary and others as secondary (as in the long run, performer satisfaction will be impacted by these other stakeholders). In my research evaluations, I divide the general category of performers into three sub-categories: performers, composers, and producers, since the Seaboard take the piano keyboard as a starting place and the uses cases and requirements for keyboards among these groups are distinguishably different. In general I have accepted O'Modhrain's four design goals, since enjoyment, playability, and robustness are necessary for any successful DMI, and I have defined the design specification in line with my research question: to build on the well-known layout of the piano keyboard to create a new instrument that more fully enables both continuous and discrete approaches to music making.

Enjoyment is the most difficult to assess in a rigorous objective way, though more qualitative methods tend to capture good information about this objective. Robustness is easy to measure quantitatively. Playability is complex, and I apply Wanderley and Orio's four categories of DMI capabilities (learnability, explorability, feature controllability, and

timing controllability) as a way to look at playability in a more granular fashion. The evidence to evaluate the extent to which the Seaboard enables both continuous and discrete approach to music making mostly lie in the video and audio recordings provided in the Appendix.

O'Modhrain's general framework provides a useful umbrella of what needs to be evaluated with respect to which stakeholders, but the question as to which specific evaluation methodologies are most effective. I have employed a range of specific evaluation methods to approach, where possible, each stakeholder and design objective from complimentary qualitative and quantitative methods.

The main qualitative evaluation methods I have used are long-term trials in-depth interviews, and ethnographic research. In addition, I have supplemented these 'deeper' forms of evaluation with broader information from surveys of online forum comments, controller user engagement observation tests, transcription authenticity tests, and listening tests.

With respect to quantitative evaluation, I have primarily relied on blind comparison testing, machine testing, durability and lifecycle tests and quantitative musical task-based tests.

Both quantitative and qualitative approaches are crucial although broadly the qualitative data is more useful when it comes to design decisions, and the quantitative data is more useful when it comes to engineering solutions and product optimization.

*When life begins, it is supple
When life ends, it is rigid.
All things, from the grass to the trees,
Are pliable in life,
And stiff in death.
...
The hard and strong will be defeated,
While the soft and yielding will triumph.⁵⁹*

—Lao Tzu, circa 200 B.C.

6.1 Seaboard 1 purpose

The Seaboard 1 concept prototype was made of a large piece of molded silicone placed in a fitted case (figures 103-107). The goal of the prototype was to provide an opportunity to explore the feeling of the playing experience. It also gave me the first opportunity to understand the issues that would need to be resolved. As a concept prototype, the Seaboard 1 had no sensor system PCB/Port, Interface, or Stand. This also meant that digitally it had no firmware, software, or way of producing sound in real time.

This chapter documents the move from a concept to a concept prototype. It tells the story of how a few sketches and an overview idea evolved into a first physical object. Ideas and objects are radically different when it comes to implication. An idea can be explained and sketched and the listener will fill in the rest. An object necessarily carries with it meanings and implications of which even its designer and creator isn't fully aware. This means that the process of physicalisation creates awareness of unforeseen problems and opportunities, and forces decisions at every turn.

6.2 Seaboard 1 elastomer

Initially I imagined that this corrugated surface would be very smooth and hard, like a touchscreen, and that pitch bend would result from gliding one's hands along the surface lightly. Quickly, though, it became clear that the lack of any throw and velocity detection would make it uncomfortable to use, and unmusical, not to mention that building a touch technology into a complex non-flat hard surface would be technologically very difficult.

Therefore, I began to focus on a soft material that would detect velocity and pressure, in a similar but perhaps more sensual and integrated way as compared to an aftertouch keyboard. I explored a large range of possible soft materials, trying out various foams and soft plastics. Soon I found that that certain soft silicones had a nice elasticity that provided a good 'action' and began exploring various samples and recipes to search for something that would meet all of the needs of the Seaboard (figures 99-101). The material choice also influenced my thinking about the exact surface shape and structure.

The concept [of softness] also suggests a closer relationship between products and users, where surfaces become like skins or membranes or objects move and react to their environment like bodies; where in short, the artificial mimics the natural.⁶⁰

In parallel to this, I started modeling various surfaces, initially out of clay, to determine what shapes would best enable discrete and continuous playing (see figures 90-92). I quickly became aware that there would be trade-offs between different shapes, some of which would be better for discrete playing, and others which would be better for continuous playing. As I made each model, I would play it and imagine the sounds it could make and whether it represented a good bridge between the gesture and the sound. At the time, since I didn't have a working prototype and was working entirely on my own, the process was entirely subjective. Indeed, since I didn't have a working prototype with which to properly test each surface variation, I decided to work with a simple corrugated-like surface since it seemed like a good midway point between discrete and continuous and also added no unnecessary complexity to the surface shape.

Although playing on a hard clay surface was far from satisfactory, it did reveal a potential problem and an opportunity. The problem was how to end the front and back of the keys. My initial drawings showed a corrugated-like design with further raised areas for the black keys, but ending the keys with a flat edge at the front and back conflicted with the organic character of the design, and brought with it no musical advantages (see figure 102). In addition, I found that the corrugated wavelike shape would be good for small bends of a half step or whole step, but that gliding one's fingers across the keys over a longer distance was too slow, too complex, and also meant that longer bends felt too connected to the structure of the twelve tone scale. Inspired by the Ondes Martinot (figures 25-26), I realised that I had an opportunity to solve the two problems of the key ends and longer pitch bends at the same time. I create a flat channel at the top and the bottom of the keywaves and had them gently morph into the channel, meaning that one could continuously glide off and back onto the keywaves. This innovation was an important part of how the Seaboard connects the discrete and continuous, and provides a way of bending the pitch very accurately over small distances, and smoothly and intuitively over large distances.

In addition to the sliders at the top and bottom, I added a palm pad to enable a gesture like that used with a tabla and other hand drums when one strikes with one's fingers and then alters the note with one's palm. I also made the top slider rise higher than the black keys (see figure 105) on the principle that the bottom slider should be below the white keys and unless the top slider was above the black keys, one would have to reach over the black keys and might be more likely to accidentally strike notes.

Having arrived at a general surface shape and material, I proceeded to begin to build the Seaboard 1, the first concept prototype. In scaling the key shape concept I had to decide whether to array all of the keys in a straight line or to create a more complex shape. As I was not concerned, at the time, with making a working prototype, I decided to give the

concept prototype a slight curve. It seemed such curvature would have ergonomic benefits, and would also help to emphasize the difference from the piano.

Another problem encountered from the beginning was the coloration of the silicone. The contrast between white and black keys is an important visual reference point for keyboard players. I found that a rigid line between black and white would be less than ideal, because it would imply a sudden change in pitch and position in contrast to the continuous nature of the Seaboard. It was important to me that the semantic implications of the coloration were consistent with the primary functional identity of the instrument. I ended up spray painting a silicone-based paint onto the top of the molded silicone, with the intention of a smooth gradient transition from black to white, but found that it was difficult to control the quality of the transition using that method (see figure 100.)

Another problem I encountered which proved to be a significant long-term research area lay in the quality of the texture of the surface. In order to make the silicone soft enough to be elastic, I added deadening agents. One result was that the surface would become sticky. At the time the best result I could find was to treat the surface with talcum powder, which created a very soft, smooth touch, but was of course messy and led to a number of problems associated with maintenance. I returned to this issue in earnest after completing the Seaboard 3.

6.3 Seaboard 1 chassis

For the proof of concept prototype, the chassis simply functioned as structure to hold the elastomer in place. The casing was an open enclosure, CNC milled from chemiwood, and then painted black. Its surfaces on the sides and back continued out from the surface of the interaction area, making for a futuristic and organic looking body with an unresolved design aesthetic.

6.4 Seaboard 1 use

Having completed the Seaboard 1 model, I was confident that the project was moving in a compelling direction, and was able to validate that by sitting at the model and exploring it, imagining how the interactions could be mapped to sounds. In order to share my subjective imagination of the playing experience and create a target for the first proof of concept working prototype, I created a video mock-up using the Seaboard 1 (see video 03).

6.4 Seaboard 1 intellectual property

The concept was also sufficiently clear to enable me to apply for a first patent application

for the Seaboard concept as a new approach to interface construction (See video 03, and refer to bibliography, Processor Interface).

6.5 Seaboard 1 user feedback

I used the Seaboard 1 to get a significant amount of very early user feedback. I showed it to a number of pianists and asked them to tell me how they would play it and how they imagined the sounds it would create.

6.6 Seaboard 1 summary

Although the Seaboard 1 was an extremely rudimentary prototype, looking back it was an effective exercise with respect to exploring and making key early decisions about the core interaction concepts and basic choices with respect to the Seaboard.

...[Y]ou cannot refine your touch without refining your ear. I am referring to two kinds of "musical ears." One is the "subjective ear," the pianist's image of the kind of sound he would like to produce. The more specific the better the results will be. The other is the "objective ear," which refers to the musician's ability to monitor the sound that actually comes from under his fingers.⁶¹

—Boris Berman, 2000

7.1 Seaboard 2 Purpose

With a clear concept model in hand, in June of 2009 I began working on the technology development in the next prototype, the Seaboard 2 (see figure 111). The focus in the Seaboard 2 was integrating a sensor system, and building a working solution for the electronic engineering, firmware, and software to begin to prove the viability of the concept.

7.2 Seaboard 2 number of keywaves

One of the first decisions taken with the Seaboard 2 was to make it two octaves, or 25 keywaves, to be precise. Given that it would be a first working prototype, there was no need to build it at scale. It was similar in shape to the Seaboard 1; I retained the curve which in hindsight was a mistake - it proved to increase the complexity of construction considerably, especially as the Seaboard 2 was a working prototype.

7.3 Seaboard 2 visual design

Little consideration was given to the Seaboard 2 visual design, as it was purely intended to test the technology. I did flatten the side edges of the case to give it a slightly more boxy form, moving away from the organic lines of the Seaboard 1.

7.4 Seaboard 2 chassis

The chassis was cast from a silicone mould that was made from a milled mould (See figure 108-109). This meant that the inside was rough, and poorly suited for encasing the necessary electronics.

7.5 Seaboard elastomer

The surface of the Seaboard 2 was slightly different from that of the Seaboard 1. The Seaboard 1 had more rounded keys, and I had sanded the mold very heavily, which further rounded the keys and created a more organic set of transitions between the various contours. For the Seaboard 2, I introduced a more geometric structure to the keys and was careful not to distort the contours of the 3D model through sanding.

I had found that it was sometimes difficult to stop on the slider accurately (a problem discussed above in relation to the Haken continuum). One variation explored in the Seaboard 2 surface was small concave dimples in the top slider to enable stopping accurately on a given note (see figures 108-109).

7.6 Seaboard 2 sensor system

The Seaboard 2 used strip FSRs, force-sensing resistors (see figures 112-113). These strips were first laid side to side, with the vertical strips lying on top. After having built a few breadboard mock-ups, and producing an extremely rudimentary schematic design, I soldered together a very rough but functional PCB.

7.7 Seaboard 2 PCB

The Seaboard 2 used an Arduino and multiplexers to read the sensor inputs and transfer them via USB to a computer. A hand-soldered circuit was included inside the Seaboard. My knowledge of electronics at this stage was very minimal, as demonstrated by the first schematic drawing I did.

7.8 Seaboard 2 ports

The Seaboard 2 had a single USB B port, meaning that it worked only with a USB B to USB B cable. At this stage the port was literally drilled into the side of the chassis and finished with a small file.

7.9 Seaboard 2 assembly

As the Seaboard 2 was a one-off working prototype, little thought was given to the assembly process. It was extremely messy from an electronics point of view, and no thought was given to how to ensure that the sensor connections would be stable. Even a little bit of movement or twisting would create sensor noise, and given the construction method, the Seaboard 2 always had a residual level of sensor noise.

7.10 Seaboard 2 sensor Interpretation

I then began to write basic code to translate these sensor inputs into musical sound. Two main areas of initial focus were organising the sensor inputs into peaks since multiple adjacent sensors could be activated by the single touch of a finger, and thus relating touches to events accurately was an essential first step. For more information on Peak tracking, please see Lamb and Roberston (2011).

7.11 Seaboard 2 software

Having identified and tracked peak events, they then needed to be translated into note events. Certain problems arose associated with the structure of the MIDI protocol, most importantly that in MIDI pitch bend is a global variable per channel. This meant that polyphonic pitchbend, the premise of having multiple notes all able to bend at the same time, required some inelegant workarounds, such as sending the Seaboard's data to ten channels at once. Nevertheless, the Seaboard 2 did work, as seen in video 06.

I began early stage work into visualizing the peaks and the notes in real-time, which proved to be an important foundation for future solutions. Using shapes and colors to represent notes and particularly to animate in real-time the continuous touch and pitch bend data was an important way to cross-verify that data. This also appealed in strengthening the feedback loop of the tactile and the aural to include the visual. It appears that Isaac Newton may have been the first person to build a tool based on this insight.⁶²

7.12 Seaboard 2 latency

The Seaboard 2 had a significant latency – enough that playing fast, drum-like patterns on it was very difficult. It was partly due to the fact the ADC (analogue-to-digital conversion) rate had not been optimized on the Arduino, and partly because the processing code in Java was far from optimized, and ran very slowly. At this point of development I had no technical data about what that latency was, or even what the target should be. It was also difficult to know whether it was all coming from the electronics and software or whether the silicone/sensor system was a contributing factor to the feeling of latency.

7.13 Seaboard 2 MMAP

The Seaboard 2's minimum and maximum activation point was not ideal. I became aware of the tension between wanting a lightness of touch and wanting a very smooth surface. Having said that, because the silicone cast was relatively thin, the minimum activation point was similar to that of a weighted keyboard which was acceptable, and this was not a particular development focus at this time.

7.14 Seaboard 2 Sound generation

In both my original concept for the Seaboard and in my thinking during the development of the first concept prototype, I did not consider sound generation and in particular timbral control in significant depth. I was not particularly familiar with the technologies

and building blocks of sound synthesis, and my focus was primarily on creating an interface which would provide better real-time control of both pitch and amplitude dynamics in discrete and continuous ways. I understood that timbre would be the big unknown to work with but generally settled for working with simple tones and samples with respect to sound generation at this stage. Initially I used simple sound libraries in Processing, as you can hear in Videos 05-07, and later moved to using samples from Logic and other VSTs.

7.15 Seaboard 2 case/transportation

The Seaboard 2 had a small bespoke case, and it could be demonstrated without removing it from its case. Despite the handmade circuits and slightly noisy sensor alignment, the Seaboard travelled well and did not have any problems associated with transportation. Occasionally the elastomer would need to be slightly adjusted in relation to the sensors or the chassis, but other than that it was entirely hassle free.

7.16 Seaboard 2 conclusions

Although the Seaboard 2 did help to prove the viability of the concept, it also revealed a number of problems. Firstly, it was difficult to get the silicone consistency to be satisfying in relationship to various conflicting demands. For percussive playing a harder surface was preferable because the material gave a nice elastic throwback when struck, but this meant it didn't have enough give for the application of pressure, and it required too much force to create an initial sensor reading because the material resistance increased.

Another issue was that the sensor spacing was essentially one sensor per key. Since pitch bends required at least two sensors to be activated at the same time, this made it impossible to both bend the pitch and play a minor second interval, i.e. a chromatic step. It turned out that this disadvantage was balanced by the fact that playing legato chromatic steps as a way of bending the pitch (rather than simply dragging the pitch with a single finger) turned out to be a highly intuitive way to bend the pitch, since legato technique is often used to create a more fluid effect on the keyboard. Indeed, the same passages of music that are interpreted for instruments capable of playing with pitch bends using a single monophonic line of notes are interpreted on the keyboard as overlapping legato notes. And because this legato pitch bend technique translates the weighted average pressure on each note into a given pitch, it allowed for very high-resolution movement of the pitch which is important for playing quartertones.

*It don't mean a thing, if it ain't got that swing.*⁶³

— Billy Strayhorn, 1931

8.1 Seaboard 3 purpose

The goal of the Seaboard 3 (figures 114-116) was to create a complete working proof of concept prototype that would be able to test all elements of playability. The Seaboard 2 was working well, but its small size, sensor noise, lack of registration, and latency meant that it showed only that the technologies were roughly the right ones—I couldn't play it like I play the piano.

8.2 Seaboard 3 number of keywaves

I particularly focused on validating the viability of accurately applying two-handed keyboard technique to the Seaboard, and to understand how Seaboard sound design would function across the spectrum of pitch, so I decided to return to an 88 keywave size.

8.3 Seaboard 3 visual design

I also moved to a straight layout, since I had found that in addition to the challenges of construction and sensor laying with a curved layout, it also made chordal inversions more difficult, since distances slightly changed between keys at the top and bottom, meaning the relative distances when playing a E flat Major 7 chord and an E major 7 chord were all different. The straightness immediately changed the nature of language, bringing the Seaboard closer to most keyboards. I began to think more about the visual design and materials, using aluminum and contrasts between silver and black to create a more contemporary feeling of thinness. Nevertheless, aesthetics was not the focus in the design and development process. I did, however, explore a wide variety of surface finishes, including in all white (figure 126).

8.4 Seaboard 3 chassis and stand

It was also a first attempt to integrate a stand since I had discovered that stability would be an important issue for Seaboards. I sketched a wide variety of solutions, and came up with the solution of using welded aluminum, integrated into the body. The thinking at the time was that an integrated stand would make it more piano-like, but it proved to be very difficult to transport, meaning that I had simply replicated an undesirable feature of the piano.

8.5 Seaboard 3 elastomer

I began to enclose the elastomer on three sides so that it would be held in place while playing. The pinching of the elastomer on the back worked well, and began to prove the viability of an enclosure approach.

I continued to explore different surface and material approaches with the Seaboard 3 (see figures 88-89 and videos 5, 12, 15).

8.6 Seaboard 3 sensor system

The Seaboard 3 sensor system was largely the same, except that I used printed multiplexing boards and a sensor-laying tool, meaning that the process was far more accurate. Unlike the Seaboard 2, it only had sensors running along the x-axis.

8.7 Seaboard 3 PCB and ports

The Seaboard 3 ran on an Arduino Mega which had 16 analogue ports. It had a power and USB device port. The port design was a little more advanced, with a laser cut acrylic that kept the ports nicely fitted.

8.8 Seaboard 3 assembly

Seaboard 3 assembly was relatively straightforward (see figures 123-125). The only tricky part, which was poorly planned for, was the attachment of the sensors to sensor inputs – a special tool was needed to click them into place, and fortunately the tolerances were such that it could be done without damaging the sensors.

8.9 Seaboard 3 sensor Interpretation and software

At first the Seaboard 3 sensor interpretation ran the same algorithms as the Seaboard 2, but soon we developed faster and more efficient systems. The Seaboard 3 software went far beyond that of the Seaboard 2. We rewrote the code in C++ using Open Frameworks, and with quite a lot of work on threading and the ADC rates, we managed to greatly reduce the latency.

One of the key questions with respect to the software was how to modulate the sensor interpretation. The issue, really, was that sometimes you would want to bend the pitch very gradually, but that might mean that it would be difficult to play in tune. I experimented with a few solutions, aware of the dangers of overautomation:

Automation has its virtues, but automation is dangerous when it takes too much

control from the user. "overautomation" —too great a degree of automation—has become a technical term in the study of automated aircraft and factories.⁶⁴

Pitch rounding is a popular, and important approach to this problem implemented commonly, for example, in various touchscreen applications where the problem of pitch bend and accuracy is even more pronounced. We found that translation functions provided the best way forward. These also meant that one could easily change the mapping between input pressure and aftertouch messages by adjusting a graph on the GUI.

8.10 Seaboard 3 sound generation

The Seaboard 3 sound generation was similar to the Seaboard 2, only faultlessly executed. Early on the sounds had glitches that made them expressive but somewhat eerie (see video 12). Significant progress was made on instrumental simulations, and a start was made on approaching interesting forms of synthesis. See videos 11-12, 14-16, 18 for more of the Seaboard 3.

8.11 Seaboard 3 summary

The Seaboard 3 was a largely effective prototype. It still functions normally, and was used intensively for practice and demos for about 2 years. Indeed, it was surprisingly hard to outmode.

*The guiding motto in the life of every natural philosopher should be, Seek simplicity and distrust it.*⁶⁵

— A. N. Whitehead, 1936

9.1 LUTE series purpose

In the previous chapters, I related the story of inventing and proving the core Seaboard concept and the development of Seaboard prototypes 1-3. In this chapter, I document the development of the LUTE series of prototypes, which took an interface concept and began to develop it into a product concept.

As a practice-based PhD in Design Products, one of the major questions was how to take this novel concept and transform it into a final product. Making a working interface simply meant that I could set up a context to demonstrate a new kind of musical functionality. I had successfully begun to create a bridge between the gestures and sounds I had imagined in the RCA cafe, but I then faced a whole range of questions about how such a bridge could exist as a product. These questions encompassed the aesthetics of the product, the necessary size, shape, materials and weight; the durability, transportation, maintenance and servicing; the sounds and specification, the control interface, and the ability to integrate into existing work environments and workflows.

In order to understand the answers to these questions, the most important first step was to get user feedback. Absent concrete and evidence-based feedback, I was operating in a vacuum, and it was impossible to correctly weigh the relative merits of various decisions to understand the best way to build the Seaboard interface into a first product.

With this in mind, I began the Seaboard LUTE series. LUTE stood for Lead-User Trial Enabled, and the first design questions were how to enable trials. Ultimately, the LUTES became working product concept prototypes.

It is worth noting here a marked difference between concept and technology prototypes and product prototypes. Concept and technology prototypes need to prove particular things to their creators, but product prototypes have to be ready to be considered in the round by a much wider community of users. In the same way that moving from sketch to a physical object means issues that are implicit or undefined are forced to be explicit, a product prototype forces the implicit assumptions about usage and perception to become explicit.

9.2 LUTE series number of keywaves

The first necessary step in enabling such trials was to make it possible to transport the LUTEs more easily than the Seaboard 3. This was the primary consideration driving the adoption of 61 keywaves as the size for the LUTEs. 88 key keyboards are difficult to transport and fit in many studio set-ups.

9.3 LUTE series visual design

In the earlier prototypes the focus was on proving functionality. Given that the LUTEs needed to begin to establish a clear concept for a first Seaboard product, questions of visual design and language became much more prominent. This was especially true given that the Seaboard was intended as a very new kind of product – one that brought about a new synthesis between the discrete and the continuous, and that brought some of the sonic possibilities achievable through abstraction in the immediate reach of the performer. Johan Redstrom comments on the challenges of understanding the object categories of a new design in *Towards user design, On the shift from object to user as the subject of design*:

When designing a chair, there is a long tradition of chairs before us that cannot be easily escaped since it is embedded within the practices of design and use. When designing a new computational thing, however, the object category might not even exist. Trying to think about how to understand it in terms of existing object categories, we find ourselves in a strange situation...⁶⁶

From a methodological point of view, it was difficult to know the right design direction without knowing a little more about the users. Up to this point, I also hadn't considered the market or customers in any detail, and this was obviously going to be an important part of designing a successful product. But before putting anything forward, a first step had to be taken to define what the LUTEs would look like.

To get the process started, I explored a number of popular techniques, like user personas, competitive analyses, keywords, design rules and so forth. Each of these methods has its virtues, and in the case of establishing a language for the LUTEs, elements of each were used rather unsystematically with an eye to returning to them more systematically on the basis of user feedback. Mood boards were particularly helpful. Mood boards are a set of visual associations:

A mood board is a collage made of images and words and may include sample[s] of colors and fabrics or other materials. They are used to convey the emotional communication of an intended design.⁶⁷

I found it helpful to create positive and negative mood boards, where the negative ones had to include elements that were interesting or somehow attractive but still unlike the

design target. A few key images helped to clarify the direction. For example, figure 133 shows the edge profile of a Canon camera with an edge feature we called the 'double pillow.' Many of the aesthetic details of contemporary electronics come from trying to create visual thinness and the right feeling in the hand. These have to be balanced against engineering considerations as well as manufacturing methods. Please see figures 134-142 for further reference examples that influenced the early thinking on various stages of LUTE development.

One clear decision was made at this stage: that the LUTE should be, and feel, thin. In deciding the design direction of the first Seaboard products, I was cognizant that the unfamiliarity of the materiality and shape could cause the Seaboard to be perceived as a gimmick or gadget rather than a bone fide new musical instrument and controller. I wanted to find a language that would express my feeling as a musician that the Seaboard was in some respects the proposal of a new kind of bridge between acoustic and digital instruments. The Seaboard brought together the simplicity of acoustic instruments with the versatility of digital ones, and it needed a design direction which felt both traditionally instrumental and like contemporary technology, indeed, that would situate it near the *virtuoso* but bring some of the qualities of the *technologist*. The general strategy was to communicate the instrumental quality through simplicity, fine craftsmanship, and premium materials and finishes, and the contemporary technological feel through thinness. Thinness provided a motif that also separated the Seaboard from keyboard, which require bulky mechanical actions, meaning that the Seaboard could also begin to have a design direction which distinguished it from the often retro look of even contemporary keyboards.

9.4 LUTE series chassis and stand

One of the main challenges in transporting any of the concept prototypes was that the chassis did not rigidly encase the silicone. Given that the tops of the keywaves had to be precisely aligned with the sensor location, any movement of the elastomer relative to the sensors would cause the Seaboard to go 'out of tune.' Thus one key premise was to make sure that the silicone would be fully enclosed on all four sides.

In order to achieve the thinness desired, as well as the contemporary language and premium feel, an aluminum unibody approach was taken. CNC milled aluminum also made sense given that the ambition was only ever to make a handful of LUTE series prototypes.

The LUTE A chassis was a chemiwood mock up. The initial concept for the chassis design was to make the top flat and have sides that swooped inwards (see figures 143-153). This was intended to highlight the thinness of the edge, but in practice the flatness of the top

was a little too stark and hard in relation to the organic undulating character of the interaction surface. In addition, the edges swooping created the impression of trying too hard to be thin.

Besides the aesthetic issues, the shape of the chassis made for a difficult assembly process, and little room for the electronics. Some key mechanical requirements were not sufficiently considered and the LUTE B (see figures 154-157) basically couldn't be effectively assembled

9.5 LUTE series elastomer

Enclosing the silicone on four sides meant sacrificing the palm pad at the front, but it hadn't proved to be crucial in early prototypes, so this wasn't a large sacrifice. With respect to the LUTE's elastomer top surface, various variations were explored, including channels and multiple dimples above the keys. These were generally rejected in favor of simplicity, especially in the early stages of the project.

9.6 LUTE series sensor system

Some LUTEs had only x-axis sensors while others had both x- and y-axis sensors, which was helpful in understanding the value of the different sensor arrangements for the playability of the Seaboard.

9.7 LUTE series PCB

In addition to introducing the double pillow, the LUTE D also was the first LUTE to feature a more advanced in-house designed PCB. This meant that it took a big step forward in both the physical integration of the PCB and ports within the chassis, and in the digital system implemented.

It was still only a controller, but could send either Sysex data or MIDI data directly over USB, as the scanning of sensors and peak tracking was done onboard.

9.8 LUTE series ports

The LUTEs A-C ran with Arduinos and didn't have bespoke ports – see the USB cable in figure 164 on the LUTE C. By the stage of the LUTE D and beyond, there were two holes for ports in the back panel. (see figures 168 and 171-172)

9.9 LUTE series control/state interface

The LUTE series also was the site for early stage exploration of the top control interface. A number of solutions were explored, from the side interface seen on the LUTE A-C seen in figures 146, 154, and 158, and the centered interface in figure 174 . Indeed, there were two primary questions at this stage – whether the controls should be centered, and how many controls or what type were needed. On the issue of centering, we tried left justification and found it to unnecessarily preference the right hand for playing and the left for controlling. On the issue of how many controls, it was difficult to judge absent user feedback and a very precise conclusion about the working modes, so we utilized one button type control and one dial type control, plus five LEDs enabling a variety of combinations to represent state.

9.10 LUTE series assembly

As mentioned above, the LUTE B couldn't be assembled, and the LUTE C was assembled with some difficulty. It used identical electronics to the Seaboard 3, but given the smaller form factor was less robust. Given these challenges, the LUTE D moved to a new approach for the body, called the double pillow (see figure 168). The double pillow meant it was easier to access the interior. Having said that, the upside assembly was also inefficient and abandoned in the next prototype series.

9.11 LUTE series sensor interpretation and software

LUTE sensor interpretation was generally robust, and a number of new features were implemented, ensuring that the pitch transitions between B and C and E and F would behave in the same way as the other musical half steps, despite the greater distance between the keys. Pitch rounding was also introduced. Many experiments were conducted on how to best build the translation functions, including relating to the release characteristics.

9.12 LUTE series MMAP

The MMAP on the LUTEs was generally worse than that of the Seaboard 3, since the elastomer was made to be 2mm thicker than that of the previous iterations and, based on the enclosure process, it was difficult to make it any thinner. This powerfully illustrated the fact that with a reasonably complex device it is possible for iterations to lose quality if integration and documentation is not sufficient.

9.13 LUTE series sound generation

During the development phase of the LUTEs further progress was made in refining the sound conceptions, and the feedback received around sound quality and approach from users was extremely valuable. For examples of the LUTE sounds, see video 19.

9.14 LUTE series case/transportation

The LUTE Seaboards' chassis design enclosed the silicone on four sides (see figures 143-144), where the Seaboard 3 enclosed it only on three, meaning it could be easily lifted up and moved out of alignment (see figures 120 and 127). Where the Seaboard 3 was more or less impossible to transport, given that the legs were not easily detachable, the LUTE was possible but still very difficult to move. The concept of the chassis design was to pinch the silicone between the top and bottom components with just the right amount of force, but in practice, if the silicone was pinched tightly it would create sensor noise, and so long as it was loose, the silicone component could be easily misaligned from the sensor array. In the case of the Seaboard 3 this misalignment was annoying, because one would have to lift the elastomer surface up and nudge and stretch parts of it from left to right to approximate correct alignment. This could take 10 minutes and was imprecise. In the case of the LUTE Seaboards though, the misalignment was much more problematic, because it was impossible to adjust the silicone component in this way without opening up the whole chassis.

9.17 LUTE series concluding thoughts

In general, my goal was to correct a number of obvious problems with the Seaboard before sending the LUTEs out for trial, since I believed that the trials would only provide feedback about things I knew unless I first addressed many of the known problems.

In retrospect, this led to two problems—firstly, it meant that I tried to improve too many elements in parallel, and in so doing took several steps forward, but also several steps back. I realised that each prototype has to have a single clear mission associated with it, and that all other improvements have to be contingent on complete confidence about the capacity to achieve the primary goal. In the case of the LUTE series Seaboards, the primary goal was to make the Seaboards more easily transportable, but the emphasis on thinness ended up significantly complicating and delaying this goal. The second problem was delay to the trials based on the need for other known improvements. Trials are extremely useful at every stage, and at almost every stage they reveal (and confirm) things you already know, and also uncover things that you don't. And each trial also shows something about the relative priorities of particular kinds of users which in the long run proves to be invaluable.

In summary, the LUTE series prototypes were an effective set of prototypes for the

purposes of (a) establishing a clear product concept for the first product to feature the Seaboard interface, (b) validating the design direction of thinness, (c) validating the use of CNC-milled aluminum, (d) revealing the extent of DFM challenges associated with building, (e) providing a first opportunity to explore the interface controls and state representation, (f) enabling graduation to a much more mature PCB system, (g) enabling extensive user testing to validate key design issues, (h) validating a color strategy for the elastomer and aluminum.

Having said that, they were far from a complete success: they were challenging to assemble, transport, maintain, and support, and the problems of integration and inter-system communication were considerable.

*Everyone designs who devises courses of action aimed at changing existing solutions into preferred ones.*⁶⁸

—Herbert Simon, 1969

10.1 PPP series purpose

The Seaboard PPP prototype series had a challenging brief – it needed to not only move forward the project towards a much more refined level of product readiness, they also had to fix major shortcomings of mechanical engineering, improve the design for manufacture, update the control stage interface, and implement some key new developments that arose from feedback from user trials.

10.2 PPP series number of keywaves

Where the LUTEs began to explore a product concept, the PPP series had to validate it into a final format ready for launch. It had become clear through user feedback that different types of performers, composers, and producers were interested in different sizes for concert, stage, and studio use. I decided to begin by launching a Limited First Edition (LFE) Series, which would represent the most complete Seaboard playing experience. For this reason, it again made sense to return to 88 keywaves, which, now at a DFM stage, had real implications for the physical build and engineering.

10.3 PPP series visual design

As development started on the PPP series, a clear picture had begun to emerge about who would be the first Seaboardists. Even when one knows one's users well isn't always clear how one should establish a 'design language.' It is clear that if an object doesn't have a consistent aesthetic orientation in the semantic landscape of other objects in people's world they will find it hard to understand, contextualize, and even properly use.

Indeed, though, it isn't clear that *design language* is quite apt as a phrase unless you are talking very broadly as in the 'design language of modernity'. A language is by definition dialogical, extraordinarily generative, and fundamentally complex. The vocabulary, usage, and possible functions of language are too broad to be analogized to the orienting identity and rule system associated with the meaning of the aesthetics of an object.

And yet the choice of any term will metaphorically suggest the nature of the process: design guidelines, formal rules, emotive DNA, aesthetic manifestos, visual grammars, interaction systems, value hierarchies, functional essences, and so forth all suggest different methods of applying criteria of some kind to a decision process. In the case of the Seaboard, the methods that were most important were defining its *core identity*, choosing an *aesthetic essence*, and then applying a set of *design principles*.

The *functional identity* is the primary definition of what the object is and how the creator⁶⁹ will perceive it. The *aesthetic essence* is the core of the whole aesthetic of the product,

the defining essence. The *design principles* are a set of high-level or abstract guidelines that inform the decision process, especially as bears on complex decisions.

In the case of the Seaboard GRAND, the *functional identity* is 'virtuosic technology.' The *aesthetic essence* is 'contemporary artisanal.' The *design principles* include the following:

Honesty

Simplicity

Generation

Holism

Each of these principles turns out to have a significant amount of complexity, and it has been necessary to develop a methodology of application which involves, more than definitions or rules, detailed positive and negative examples.

10.4 PPP series chassis and stand

Although the surface look of the PPP is similar to that of the LUTEs, the chassis design is radically different. Both the top and bottom are milled, but the milling was much more efficient in terms of use of materials, and having a milled bottom case made the whole design much more efficient for assembly. The bottom features a milled structure which maintains high strength, whilst reducing weight (see figures 212-216).

Significant work at this stage went into designing the stand, from researching other stands on the market to thinking more about the ideal Seaboard playing experience. In the end, strength and simplicity of lines became the most important considerations. The PPP stand was marginally too thin, though, especially with respect to left-right movement as when one would play with vibrato. The PPP Seaboards would rock back and forth. This informed the final Seaboard GRAND stand design.

10.5 PPP series elastomer

The PPP elastomer went through many more iterations to achieve the right standard with respect to MMAP and durability. As seen in figure 211, some of the early versions were too soft and this also created unattractive visual lines at the top and bottom, and caused laddering when trying to slide across the surface.

10.7 PPP series PCB

The PPP series featured a much more complex and advanced architecture, featuring an ARM processor and a dedicated DSP chip. This meant that all the sensor interpretation and sound generation could happen on-board.

10.8 PPP series ports

In addition to power and USB device, the PPP also had audio out, three continuous pedal inputs, and USB ports.

10.9 PPP series control/state interface

After receiving feedback suggesting that many users would look for, expect, and need different on-board controls, I decided to limit the physical controls to a single push button and a continuous action rotary controller. Considerable engineering went into building this into a beautiful interaction with a heavy premium feel to it. See figures 193-217.

10.11 PPP series sensor interpretation and software

The PPP sensor interpretation and software was functionally similar to that of the LUTEs, with the exception that the sensor interpretation ran on-board, meaning that the PPP could function as a stand-alone MIDI device.

10.12 PPP series sound generation

Although sound is of course fundamental to the Seaboard, I haven't discussed it in detail yet because the earlier prototypes were controllers and were mostly used with a variety of external sound engines and sound design tools. Sound generation is one of the most important issues in the development of the Seaboard, and many of the fundamental design questions reappear in another form, another medium. A number of key questions arise in relation to sound design and the aesthetics and technical implementation of sound for a multi-dimensional controller. What should the Seaboard sound like, or perhaps, what should the centre of the Seaboard's sonic centre of gravity sound like? Which kinds of sounds are generally effective and why? Why is the mix of samples and synthesis more important and promising for the Seaboard than for other types of instruments? What kind of rules, if any, should apply to sound design?

It is difficult to say, or perhaps prejudge, what the Seaboard should sound like. It is also more accurate to say, what each Seaboard sound-map should be like, since the interactive mapping is a key part of the design of every sound. With regular MIDI keyboards, the velocity range is so well-known that it is not strongly considered as an independent parameter. With the Seaboard, adjusting the way that an initial velocity is mapped to a

velocity output is important, as is adjusting the way a continuous touch input maps to a continuous touch output. This means that physical input maps onto an abstract category of note data, before being translated into sound. The interactive mapping, and an understanding of the affordances it creates for performers, is an essential part of the sound design process – designing sounds as one would for a MIDI keyboard will simply not produce dynamic results. Moog speaks of this as the musician-instrument system:

How can it be that musical instruments are both sophisticated technological devices and quirky artefacts that often seem to border on the irrational? I believe that the answer lies in how musical instruments are used. Music making requires both the musician and the listener to function at the very limit of their perceptive and cognitive capabilities. Therefore, a musical instrument has to be as effective as possible in translating the musician's gestures into the sonic contours he is envisioning. When he performs, the musician feels his instrument respond as he hears the sound that it produces. In terms of modern information theory, the musician-instrument system contains a multiplicity of complex feedback loops, so complex, in fact, that contemporary technology has so far not been able to analyse or characterise the nature of the instrument-musician interaction with precision or completeness.⁷⁰

In terms of the Seaboard's sonic centre of gravity, many of the keywords established as design principles have application here: *Honesty* means that the sounds are fit for purpose, and that they are Seaboard sounds – not pure replications or simulations of anything else. *Simplicity* means that sounds may be very complex but not unnecessarily cluttered or complicated. *Generation* means that the sounds inspire creativity and exploration (and that the sound design tools are generative of new possibilities). *Holism* means that we listen to the Seaboard and all its sounds as a whole, with special attention to the multi-dimensionality of that whole. The Seaboard is a multi-dimensional controller, so it is important that the sounds are multi-dimensional. Other words used to denote principles for elements of the Seaboard that apply to the sound generation, designs and mappings include sensuality, textural depth, and versatility.

This only gives us a very general verbal and associative handle on the nature of the Seaboard's sonic centre of gravity. As Eaton and Moog commented, "unquestionably, an element missing in much electronic music is human nuance...."⁷¹ High dimensionality of parameter control obviously gives the musicians the tools to create nuance, but what that nuance should actually sound like and how it should be contrasted is a difficult question.

A more practical question might be to ask which kinds of sounds are generally effective and why. In practice the most effective sounds are sounds that have been designed specifically for the Seaboard. Layering sound elements is often effective, as one has to

find the right way of mapping continuous touch inputs to sound variables. The secret to effective Seaboard sound design to the extent that I have discovered it, is a variety of rich elements (hear audio 19 for a good example of such a sound), and a very flexible modulation matrix.

Why is the mix of samples and synthesis more important and promising for the Seaboard than for other types of instruments? The Seaboard is very sensitive when it comes to different kinds of attacks, and sample elements have been found to be very effective in bringing a huge range of subtlety to the attacks on the Seaboard, especially harder percussive attacks. Synthesis, on the other hand, is typically better for carrying the subtlety of internal variation afforded by continuous touch. These aren't iron rules, though, and we have seen some beautiful and impressive synth attacks and excellent examples of sample variation. I don't believe there are any hard and fast rules, only guidelines. Every sound-map should identify a range of modulation, and then every point within that range should generally alter the sound.

10.16 PPP series summary

The PPP series of prototypes was extremely effective in rapidly moving the Seaboard towards completion as a finished product, and resolving many of the thorny issues associated with the design for manufacture, as well as helping to establish a much more refined set of tools and criteria for sound design and mapping.

What makes something simple or complex? It's not the number of dials or controls or how many features it has: It is whether the person using the device has a good conceptual model of how it operates.⁷²

—Donald A Norman, 2011

11.1 GRAND series purpose

The purpose of the Seaboard GRANDs was to make a high quality product that would delight customers, and effectively launch the Seaboard as a new musical instrument. The goal was to start the process of building a community by starting with the absolutely highest articulation of what a Seaboard could be. We started with a Limited First Edition of 88 full-size Seaboards (see figures 218-238), and then we moved on to design the Seaboard GRAND Stage (see figures 239-245) and the Seaboard GRAND Studio (see figures 246-253), which were broadly similar but came in 61 keywave and 37 keywave sizes.

11.2 GRAND series number of keywaves

Continuing with the logic established with the PPP series, the Limited First Edition would have 88 keywaves, with the two smaller sizes as above.

11.3 GRAND series aesthetic design

The visual design was almost entirely consonant with the PPP series. Minor changes to the stand and small interior DFM elements were changed, and with the introduction of the case, the aesthetics of the whole were altered towards a more 'complete package' but otherwise were identical.

More broadly, though, during the GRAND series design process, I was able to take a more systematic approach to the aesthetic criteria.

In addition to the design principles which reach across the entire project, I established particular principles to guide the aesthetics of the visual, tactile, and aural qualities of the product. Visually, the principles are thinness, CMF minimalism, and symmetry. The tactile design principles are sensuality, textural balance, and subtlety. And aurally, the design principles are immediacy, depth, and versatility.

11.4 GRAND series chassis and stand

The chassis design was identical, though a new more robust stand was developed (see figures 227-230).

11.5 GRAND series elastomer

Final issues were resolved in the elastomer to provide a durable and subtle surface for playing. The design focus in this stage has moved towards developing more objective ways of testing and performing QA to ensure superb product quality for every unit.

11.9 GRAND series Control/state interface

The sound dial (see figures 254-258) is well-engineered and has a lovely weight to it. It is very complex and labour intensive, but feels worth it in delivering a premium-feeling interaction.

11.10 GRAND series assembly

The assembly process has been streamlined and clear standard operating procedures are in place. The Seaboard is assembled in Dalston, east London, in a railway arch (see figure 219).

11.11 GRAND series case/transportation

A durable case (see figures 263-275) now provides a unique packaging, unboxing, and transportation solution.

11.12 GRAND summary

In concluding it is important to take realistic stock of the areas of strength and weakness of the current product, especially with regard to the original question set out at the beginning of this thesis:

Can one create new multi-dimensional interfaces which provide more effective ways to control the expressive capabilities of digital music creation in real-time? In particular, can one build on the intuitive, logical, and well-known layout of the piano keyboard to create a new instrument that more fully enables both continuous and discrete approaches to music making, in which the benefits of use outweigh the challenges of learning?

There are many areas where the Seaboard has been successful. The Seaboard is certainly an innovative musical controller and instrument. It is related to instruments like the Continuum and the piano, but clearly distinct from both. It has received recognition for its innovations, and generally brings the pleasure and excitement that innovations often do.

The materiality and surface of the elastomer of the Seaboard, along with the gestures it suggests are unusually sensual. Players frequently comment on this. It strongly adds appeal to the instrument and the intimacy of physical and sonic relationships that can be

created with it.

The overall interactive experience of the Seaboard is strong, most importantly because musicians find it to be highly expressive and thus very useful. It clearly enables virtuosic playing, but even beginners can enjoy the interactive quality of the Seaboard, especially its continuous touch.

There are also a number of areas where the Seaboard will benefit from further development.

These include the MMAP, which will benefit from enabling much lighter touches. The accuracy of playing could be improved through slightly adjusted key shapes and textural guides, and also developments in the sensor interpretation algorithms. The visual clarity of the Seaboard, especially with respect to the contrast between the natural and accidental is another important issue. This is particularly important for low and stage lighting contexts, and it may simply be higher contrasts, or other kinds of contrasting surface finishes. The integration with especially composers and producers existing workflow could certainly be improved. Maintenance of the Seaboards is not a problem, but dust can be an issue, and further research is necessary to find surface finishes that are easier to clean. The cost of the current units is still too high, and related to this, the assembly time needs to be dramatically reduced. The Seaboard's onboard sound engine is still in development, and will greatly improve the experience of using the Seaboard when it is ready.

This is a long list of areas for further work and should not be glossed over or underestimated. It is exciting, though, to already have a community of supportive musicians, because ultimately their usage and feedback will help create the opportunity to make the Seaboard into a truly refined musical instrument.

*I dream of instruments obedient to my thought and which with their contribution of a whole new world of unsuspected sounds, will lend themselves to the exigencies of my inner rhythm.*⁷³

— Edgard Varese, 1917

12.1 Future Seaboard purposes

The Seaboard GRAND is just the beginning of a longer design practice. In the same way that piano keyboard interfaces have had many applications, I hope to continue to develop new and better applications of the Seaboard interface. At a broad level, they might have a similar range of purposes that we see with keyboards, as primarily polyphonic pitch and velocity input systems coming in all shapes and sizes. At a more granular level, the purpose of future Seaboards will be to make the expressive capabilities of the Seaboard more and more accessible and compatible with a wide variety of systems and contexts. The following chapter discusses some of the necessary next steps to ensure that the Seaboard interface continues to evolve.

12.2 Future Seaboard number of keywaves

Clearly future Seaboards can come in a wide variety of sizes with respect to the number of keywaves. A more interesting question that will arise will be to what extent the vertical size of the keywave can be reduced for smaller designs without overly sacrificing playability. This will partly depend on the implementation of the y-axis and the functions attributed – see below.

12.3 Future Seaboard visual design

One key question for the future of the visual design of Seaboards is the extent they develop as instruments vs. interfaces. The distinction is mostly driven by where the sounds are generated, and also, by the extent to which the sounds are specifically designed for the Seaboard. Interfaces by their natures are a component within a larger design, and that means they are far less able to dictate a given visual language. Instruments, on the other hand, are complete objects in their own right, and have to have a much stronger visual identity. Either way, the organic soft lines and materials that are central to Seaboard interfaces will have an impact on the language of any product where it is utilised.

12.4 Future Seaboard chassis and stand

There is little to speculate on here, except that there are opportunities to build even thinner chassis structures, and lighter stands with more of an emphasis on cable management.

12.5 Future Seaboard elastomer

New materials will be explored for future Seaboard elastomers. The refinement of surface

textures is an important and ongoing area of research, particularly in terms of how different surfaces provoke, suggest and enable a variety of musical gestures. Another consideration is creating new contours to the surface for similar reasons.

12.6 Future Seaboard sensor system

In the Seaboard GRAND products the decision was taken not to implement y-axis sensing primarily because the sensor technologies explored at that point to deliver 3D pressure sensing were not robust enough to put onto a manufacturing roadmap. Having said that, y-axis sensing will be an important feature of future Seaboards.

There are two ways to utilize y-axis sensing, one which is relatively trivial and one which is more complex.

The trivial way to implement y-axis sensing is to use in ways that augment but don't fundamentally change the basic current functionality of the Seaboard. Two examples of this are chromatic chordal inversions and pitch transitions.

The current Seaboard GRANDs do not enable the playing of a chromatic chord – i.e. playing two contiguous semi-tones at the same time, based on the sensors' shape and the need to scan multiple sensors to create a peak location in the sensor data. In practice, the relative pressure between two chromatic keys is an excellent way to precisely bend the pitch, and in most cases the value of this will outweigh the importance of playing a chromatic chord. Having said that, there are of course times when one wants to play rich chords that include contiguous semitones, and this is a real limit. With the y axis implemented, one could set a rule that when the touches on two contiguous keys are more than an inch or so apart on the y axis, then two notes are played, and when they are closer than an inch, then a relative pressure pitch bend or pitch slide is created.

Another example of a way in which y-axis sensing could make a difference to playing quality is pitch transitions. Although the non-planar surface of the Seaboard is excellent for enabling discrete and continuous types of user inputs, the sensing solution with an implemented y-axis is difficult to tune to work perfectly for both discrete and continuous modes of playing. With a y-axis, different regions of the interaction surface such as the keywaves in contrast to the sliders could be programmed with different algorithms further optimizing for very smooth bends and in-tune discrete note playing.

There is of course a much more ambitious approach to the y-axis, hinted at in one of my first sketches (figure 82): mapping the y-axis to further variations in timbre. The advantages of mapping the y-axis are obvious. One can play a key and then push one's finger upward or downward to alter a given pre-programmed parameter. Each additional

parameter adds significant possibilities.

There are two ways of implementing y-axis mapping - multitouch y-axis and single touch y-axis. The Continuum, for example, has a single touch y-axis, meaning that you can play an array of notes in the x-axis and each has a single y position. With multitouch y-axis capability, you can create an array of touch events with x and y coordinates. In practice, assuming that pitch continues to be mapped to the x-axis, you get an array of 'notes' in the x-axis, and each touch in the y-axis can then be interpreted in a number of ways: firstly, they can simply trigger more notes, which radically speeds up the ability to repeat notes and have essentially legato repeating notes, like one does when holding the sustain pedal and repeatedly playing a single note, except that different kinds of sound interactions and effects can be associated with the repetition, and the interval of repetition can be much shorter than the time it takes a mechanical key to rise back up. Secondly, additional touches on the y-axis can be programmed to alter additional sound parameters. One of the unresolved challenges associated with this potential is creating a user-friendly interface, since the complexity of the mapping will be exponentially increased.

12.9 Future Seaboard Control/state interface

There are many possible iterations of a control state interface – more buttons, less buttons, screens, and so forth. These depend on the nature of the future product using the Seaboard interface. One control/state related consideration in the design of the Seaboard interface itself that has come up several times both in the earliest stages of concept ideation through to recent feedback is backlight the top surface. It is certainly possible, though because of the contoured surface technically not trivial to achieve a very high standard of quality, and the idea is certainly something that I have carefully considered. Unlike adding a Y-axis, though, which would be a clear net win, backlighting would have huge advantages but also significant disadvantages.

In terms of advantages, backlighting would provide at least four—a more magical experience, better state communication, multi-sensory confirmation of interaction, and better opportunities for communicating complex interactions.

In terms of disadvantages, there are two main ones: the re-emphasis of the visual, and the difficulty of resolving the aesthetic language. The re-emphasis of the visual is a problem simply because the Seaboard is so fundamentally based on forging a closer and more intuitive relationship between the tactile and physical gesture, and sound and listening. Sight here is something of a risk, because it is such a powerful sense that overwhelms the others. This isn't simply a question of observing how important it can be for musicians—especially performers—to close their eyes while they reach for depths of expressions with

their instruments. Rather, it is an understanding that while the bandwidth of our capacity for interaction is by no means a zero sum game, there are constraints when it comes to the balance of power between the senses.

The difficulty of resolving the aesthetic language is a related problem. Most forms of illumination project the language of 'electronics' and even 'gadgets'. These semantic associations are dangerous for future Seaboards because they create a conflicting set of meanings. Pointedly, no traditional acoustic instrument has such a language, and so it means either letting go of the aesthetic language of musical instruments entirely, or risking a compromised and portmanteau approach from the outset. It might be that limiting the color of the lights, or creating more organic look to the light is enough to pull away from the decidedly technological and gadget-like quality of illuminating interfaces.

12.12 Future Seaboard software

Visualisations are an important and on-going area of research and development. The new paradigm of physical input translating into note data which then translates into sound is not immediately intuitive, and good visualization software can immensely help to make that process more intuitive to understand and manipulate.

12.13 Future Seaboard MMAP

MMAP is an important research area for future Seaboard development. Creating the capacity for lighter touches from a hardware perspective is an essential objective to improve the Seaboard playing experience, and ideally to create the scope for a wider possible set of gestural inputs. This will impact playing speed, glissando speed and a range of other fundamental techniques.

12.14 Future Seaboard sound generation

Can one go forward without going back? Aftertouch keyboards like the CS-80 provide a helpful roadmap and background, as well as a sonically recognizable reference for Seaboard sound development. And studying instrument simulations, vocal dynamics, and pianistic overtones are all an important for understanding the sonic potential of an instrument like the Seaboard.

Ultimately it all comes down to the tools. Multi-dimensional controllers need multi-dimensional sound engines with exceptional modulation matrices to be effective. And a further problem comes in the development of intuitive and attractive GUIs for designing sounds for multi-dimensional instruments. Ed Eagan's EagenMatrix synth is certainly one of the best sound engines ever made specifically for a multi-dimensional controller, and yet it is relatively difficult to learn and use for many sound designers.

12.17 Future Seaboard learning processes

To build a community and a culture around the Seaboard, one of the most important supporting activities is creating excellent learning tools and resources. Seaboard pedagogy is a complex subject in itself, though, and especially as the design and sound mappings are evolving quickly, it is difficult to establish a coherent and stable methodology. Also, it is worth noting in detail how the subtlety of the Seaboard will mean that its pedagogy requires a very thoughtful approach, building on the pedagogy of the piano and other instruments. Consider, for example, the thought and research that has gone into a single issue of piano technique, the touch, and its relationship to tone.

in 1925, Otto Ortmann penned a classic work entitled *The Physical basis of Piano Touch and Tone*. He began:

What we actually hear and what we imagine we hear, what we actually do and what we imagine we do, when listening to or playing upon a piano are distinctions urgently needing a clear exposition.⁷⁴

After a long investigation, he concludes:

What we actually do, then, when playing the piano is to produce sounds of various pitch, intensity, and duration. Nothing more. Certain forms of touch are effective only because they enable us to secure a proper relationship among these variables. The quality of a sound on the piano depends upon its intensity; and one degree of intensity produces but one quantity, and no two degrees of intensity can produce exactly the same quality. If A plays “poetically” and B does not, then, as far as the single tone is concerned, A plays sounds of different intensity from those of B; and if B could play sounds of the same intensity as A, B would play just as poetically and A.⁷⁵

This is certainly not the case with Seaboard – the touch does have a huge impact on the tone, as it can alter a wide range of parameters. And so where there has been debate about the effects or lack thereof of a given type of touch on the piano, with the Seaboard it is ultimately a question of how one should go about learning and mastering the instrument.

*Music was born free; and to win freedom is its destiny.*⁷⁶

—Ferruccio Busconi, 1911

14.1 Evaluation in retrospect

As discussed in Chapter 5, a number of qualitative and quantitative methods were used to evaluate the extent to which the Seaboard met its design goals from the perspectives of a number of key stakeholders. The evaluation techniques employed were often strategically chosen at a given moment in the design process to inform a given decision, and over time these partial evaluations have amounted to a reasonably comprehensive data set spanning qualitative and quantitative issues for all relevant stakeholders. In hindsight it is easy to present these as systematic, and they do provide ample material to enable one to retrospectively look back and establish a richer intersubjective basis for evaluation.

Primary methods included trials, in-depth interviews, and attempts to understand performers, composers, and producers through frequent engagement over a long period of time. My own high level qualitative assessment on the basis of these evaluations is that the Seaboard succeeds in providing a satisfying new way to create music that is both continuous and discrete. Although quotes can of course be taken out of context, the strength of the following remarks from eminent musicians helps to support this conclusion. Hans Zimmer, Oscar-winning film composer said, for example, “Roland Lamb and his team are actually much closer than anyone else has ever come to... establishing a new, truly expressive digital instrument.” And Vijay Iyer, Grammy-nominated pianist, producer, and MacArthur Genius Grant recipient expressed the contrast between the piano and Seaboard eloquently:

Although I still believe in the power and subtlety of a good old-fashioned grand piano, I’m excited about the Seaboard because it signals a new future for keyboard instruments. The best such instruments are not mere piano substitutes, but actual conceptual abstractions of the piano, with their own distinct identities. And as far as that goes, this is one of the best I’ve ever experienced. Most importantly, the Seaboard is winningly intuitive to play, putting the expressive power where it belongs — with you, in the moment, right under your fingers.

Jordan Rudess, Grammy-nominated virtuoso in Dream Theater, MusicRadar’s “Greatest Keyboard Player of All Time” has also served as Head of Musical Experience at ROLI and thus his opinion is far from objective. Having said that, Rudess is well recognized as a leading global expert in keyboards, controllers, and new musical interfaces, and has perhaps more experience testing new musical instrument designs than any other living person. He speaks of the Seaboard in glowing terms. “The Seaboard has opened up enormous creative potential and has forever changed the world for modern day keyboardists. For me, discovering the Seaboard has been the most important musical life-changing event since my first synthesizer.”

Please see the videos for further discussion of the Seaboard and its capabilities by a selection of artists. I should add that not everyone loved the Seaboard – some found it too strange, or were put off by the difficult workflow required to edit and set up new sounds. But based on the variety of evaluative methods employed, the general consensus was one of interest and enthusiasm, and those that spent the time to learn and practice the Seaboard confirmed that represents a new way to approach both discrete and continuous approaches to music making.

As discussed, I used the LUTE Seaboards (LUTE stood for lead-user trial enabled) for long-term trials. Even after the LUTE series was retired, various trials have continued, both with leading artists and in the context of music institutions as well. For example, Trinity Laban conducted an extensive trial involving a wide variety of tests and experiments and documented their work on Facebook.⁷⁷

These findings have been supported by a variety of secondary methods, like surveys of online forum comments, controlled user engagement observation tests, unit sales, customer feedback, and more. Online forums including comments on YouTube, and a number of news websites included both strongly positive and strongly negative responses. The Seaboard appeared to touch a chord, so to speak, with people whether that was major or minor. The differing opinions generated significant interest which led to a large number of sales, and now that the Seaboard is shipping, customer feedback directly to us and on a variety of online channels has provided an excellent sources of arms' length evaluation, and generally the reviews have confirmed the success of the instrument. One customer has set up a blog dedicated to the Seaboard, Seaboardist.com, and this provides an in-depth resource for understanding one person's experience.

In addition to qualitative research, quantitative research such as blind comparison testing and machine testing has been used consistently to test user assumptions and interpret user responses correctly. Seaboards are regular tested by a group of testers who are blindfolded and then perform regular timed tasks on the Seaboard and then rate the Seaboards in relation to a variety of criteria. This has helped not only to ensure robustness and consistent quality, but has also helped to bridge more subjective responses about various kinds of touch with particular measurable parameters.

In summary, although formal evaluation methods have been helpful in the design process, and are an important part of stepping back and understanding the contribution of the practice as a form of replicable research, the complexity of the issues involved, and the number of incommensurate problems faced has meant that systematic formal rigor has had to be strongly supported by a more fluid ongoing interpretative process of listening and intuition.

14.2 Summary of research results

Taking into account the areas where the Seaboard GRAND has strongly succeeded and the areas where more time, research, and effort will be required to progress, one can return to the original questions at a slightly higher level:

Can the intuitive, logical, and well-known layout of the piano keyboard be reimaged to create a new instrument in which the benefits of use outweigh the challenges of learning? Can new multi-dimensional interfaces provide more effective ways to control the expressive capabilities of digital music creation in real-time? Is it possible, and if so how, to achieve an integration of relevant sensor technologies and design concepts and techniques to create a new kind of musical instrument and sound creation tool with a satisfying result for leading musicians—including performers, composers, and producers—who have piano playing skill?

The answers to these questions is: yes, yes, yes, and to the question of how, I hope that the foregoing practice-based research has shown that experimentation, iteration, subjective and objective testing and analysis in a rigorous but nevertheless creative and open-ended design process provides a methodological way forward. And more specifically, the final work produced, the Seaboard GRAND Limited First Edition, and the Seaboard GRAND Studio and Stage prototypes materially show how a successful integration is achieved. It is important to stress that these only represent one answer to the question of how, and there are other good answers that already exist, such as TouchKeys, and many more that haven't been invented or explored but which could further open up this exciting new area.

The above trio of yesses should not, however, be interpreted for unchecked enthusiasm. There are areas in which challenges have been significant enough to warrant real pause about the long-term chances for any such new musical interface to really take root. Four particular challenges stand out: the abstract vs. the immediate, the discrete vs. the continuous, variations vs. disruptions, and ecosystem viability.

The challenge of the abstract vs. the immediate is that ultimately the definition of what we experience as real-time is well defined and dualistic – other than a very small threshold, we either feel that that something is happening in real time or not. From a design point of view, there is nothing we can do to overcome this duality since it appears to be a feature of the processing speed and capacity of our sensory experience. The best we can hope for is to translate some number of production capabilities that are abstract for the sole reason of the processing speed required to deliver the functionality into more immediate real-time activities as computer processing speeds increase.

In the case of the discrete vs. the continuous, we can be a little more hopeful since there is no such absolute division between the discrete and the continuous with respect to sound. Physically it is difficult to escape trade-offs between the two, and the challenges in achieving accuracy in fast percussive playing on the Seaboard shows this; some level of compromise is likely a fundamental long-term design challenge.

The problem of variations vs. disruptions is that variations are insignificant but easy to absorb. Disruptions are game-changing but often impossible to adapt to. The work of the innovative designer, perhaps, is to find the space in which to design something challenging enough to be transformative but familiar enough to be understood and used.

And finally perhaps the most significant problem of all is ecosystem adoption. No matter how good an idea, it has to be embraced by a wide enough community for it to take root. Consider this quite typical description of the release of a new higher-dimensionality keyboard:

..[t]he greatest opposition that this new instrument has suffered consists in the fact that people in general do not know how to play it at the first encounter, since an ability to play keyboards will not suffice here. Being a new instrument, it requires a person who understands its virtues, who to some extent has made a particular study of it, so that he may regulate the measure of the varying impulses that he must impart to the keys in order to achieve graceful gradations at the right time and place...⁷⁸

This was Marquis Scipione Maffei writing about the early responses to the pianoforte. I am confident that the Seaboard is a new kind of musical instrument and sound creation tool that engages musicians with piano-playing skill, but it is entirely another matter whether it will become an important and durable approach to music making, and one which can't yet be judged.⁷⁹

14.3 Methodological lessons learned

The process of developing the germ of an idea into a finished product has led to some conclusions about methodology which will bear on the design practice going forward. In the shortest form possible: be precise.

Listed out in a few steps, effective development means to (a) assess objectives, (b) reduce complex propositions to simple propositions⁸⁰ (c) prioritise (d) establish precise shared terminology, (e) isolate parameters, (f) model everything mathematically where

possible, (g) articulate hypotheses, (h) design controlled experiments, (i) focus on the measurement tools and systems, (j) conduct subjective and objective testing in concert, (k) compare qualitative and quantitative results, (l) analyse data across all development areas in a single framework.

14.4 Softness in design

The process and practice of inventing, designing, developing and refining the Seaboard has informed an approach to design broadly speaking, and a number of important observations which will imprint my future work. One important tenet of the design approach is softness, captured beautifully in this passage from the History of Modern Design by David Raizman:

...“soft” approaches to design often focus upon the intellectual in addition to physical or aesthetic aspects of design. In this view both the computer and the notion of information have become the new common denominators of design activity. In our present “post-industrial” age of electronic information and imagery, the term “soft” encompasses not only the digital manipulation of virtual and easily modified images so prominent in many areas of design, but also the complex task of creating information systems or instructions (software) to facilitate the process of manipulation itself. In this way the boundaries between design, information science, and artificial intelligence have become more fluid, and collaboration in academic and industry settings suggest the relationship between technology and the existing training and practice of design is changing. As software becomes more sophisticated, a greater understanding of human psychology and that makes traditional boundaries permeable, not just boundaries between machines and craft production, but boundaries between machines and the creative process itself.

Long as that quote is, it illustrates a range of elements that resonate strongly with this research: the multi-disciplinary nature of the work undertaken, the necessary ties between academic and industrial development, the role of human psychology in the design process alongside more technical systems and skills of formulation. And it is somehow fitting that the Seaboard is literally one of the softest physical interfaces ever made. The physical softness and the ethos described above are part of a movement in which hardware design is learning from software, just as software is now increasingly influenced by hardware design.

14.5 Expanding the bandwidth of interaction

The Seaboard has opened up a number of compelling technological and design opportunities. As a general approach to interface, it enables non-planar surfaces, subtle

variations in surface shape and texture to guide touch interactions, which not only creates the possibility of new musical interactions; it opens up the bandwidth of interaction.

In Chapter 1, I presented some very general, high-level considerations about how the senses can and cannot be conditioned by material and social circumstances, about fundamental associations between the senses, and the key concepts of discreteness and continuity, abstraction and concreteness that emerged from these associations.

The design practice developed in relation to the Seaboard to this point suggests that an awareness of sensory associations and these other concepts in relationship to them can be helpful tools in effective decision-making. More broadly the practice has suggested a direction of 'expanding the bandwidth of interaction' between people and their instruments that can be further explored and developed.

The idea of the Seaboard began with the imagination of a new interaction between gesture and sound. It came about because my own gestural and sonic imaginations found a new point of connection.

The other day I demoed the Seaboard at Abbey Road Studios in London. Heen-Wah Wai, a Seaboard product demonstrator at ROLI, played a beautiful piece of new music on a plucked sound with a nice long sustain. I noticed that he had started using the flat side of his thumbs to bend notes along the bottom slider and the pads of his fingers to slide along the top slider. He would arc between notes, beginning and ending touching or in the crevasses between the key ends. On the bottom slider, when playing an E with his right hand, for example, the tip of his thumb would sit on between the D and the E, directly aligned with the E-flat. He had adapted to the flat of the side of his thumb to increase the surface area of contact and thus reduce the friction of movement – furthermore, the side of the thumb is closer to the bone, and thus causes less friction than the front pad of the thumb. But because the contact with the surface ran from just above his thumb knuckle to near his nail, the tip of his thumb would need to be displaced by about a half step to be in tune.

It was a new possibility that emerged from a connection between Heen's gestural and sonic imagination. Perhaps this is a more fundamental thing to aspire for as an inventor and maker of new instruments—that one can imagine new connections between gesture and sound and create the instruments to make those imaginings possible, and that others will use the instruments in their own ways to find new connections and possibilities that one can see and learn from.

This is an example of the idea of expanding the bandwidth of interaction. That bandwidth is not determined only in a real-time sense of how much data we are sending to and

receiving from our input devices—it is also defined by the extent to which, and the speed at which, our interfaces can evolve in relation to our needs and interests. Accelerating this process means accepting the on-going and unfinished nature of the work. In the Poetics of Open Work, Umberto Eco suggests that openness is the situation of contemporary art:

...[A]gainst the background of historical influences and cultural interplay which links it by analogy to widely diversified aspects of the contemporary world view, the situation of art has now become a situation in the process of development. Far from being fully accounted for and catalogued, it deploys and poses problems in several dimensions. In short, it is an open situation, *in movement*. A work in progress.⁸¹

This is not just the state of art – it is the state of interactive technology and design, of interface. This is the way we must approach technology to expand the bandwidth of interaction and improve the core interactive feedback loop at the heart of any real-time sensory interface.

The Seaboard does not bridge the gap between immediate real-time and abstract approaches to music making, but the way that it brings together discrete and continuous possibilities is only possible in a technological age of abstraction. And although it doesn't bridge the gap, by expanding what can be done in real-time, it softens the sense that the expressive capabilities of acoustic instruments and digital tools must be ever divided. It proposes a way that the virtuoso and the technologist can begin together, and suggests that perhaps there are other solutions which will further close the gap between the two.

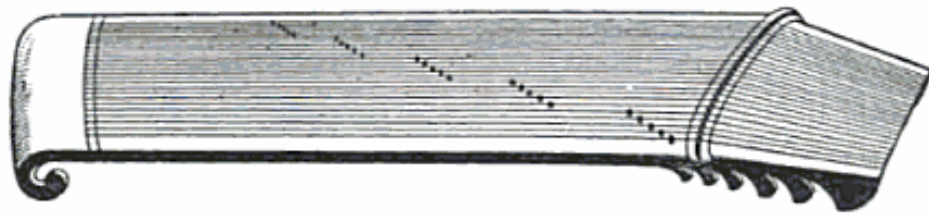

Chinese Ke, 2650 B.C.

Figure 1
Chinese Ke (front perspective)
circa 2050 B.C.

The Ke was the first string instrument in the historical record.

Image source: *Pianos and Their Makers: A Comprehensive History of the Development of the Piano From the Monochord to the Concert Grand Player Piano.*

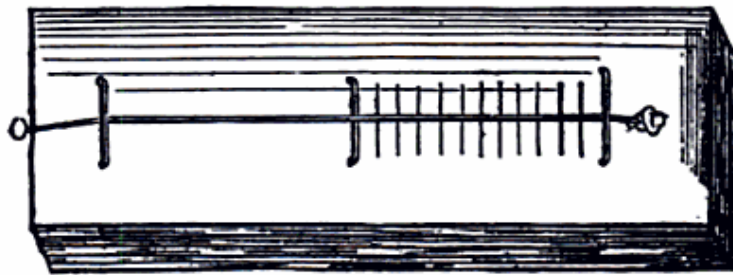

Monochord, 582 B.C.

27

Figure 2

Monochord (top view)

circa 582 B.C.

The monochord was constructed of a single string glued to the top of a wooden box with intervals of the scale marked by strands of tape perpendicular to the string. The player produces sound by simultaneously placing a finger down on a given interval mark and plucking the string. Guido of Arezzo modified the monochord in 100 A.D. by adding a moveable bridge under the monochord string to create a quicker and more correct intonation. Clavis (keys) were a design feature added to the Monochord. Each key had a tangent or pricker, which would prick a corresponding string to create a more accurate sounding of each tone. During the 12th and 13th centuries, designers made an important modification in keyboard instruments. They increased the number of strings to increase the scope of playable notes.

Image source: *Pianos and Their Makers: A Comprehensive History of the Development of the Piano From the Monochord to the Concert Grand Player Piano.*



Figure 3

Pythagoras

circa 570 B.C. - 496 B.C.

Pythagoras used the monochord for experiments pertaining to the mathematical relations of musical sounds.

Image source: http://forum.banglalibrary.org/extensions/image_upload/images/1376067211.gif

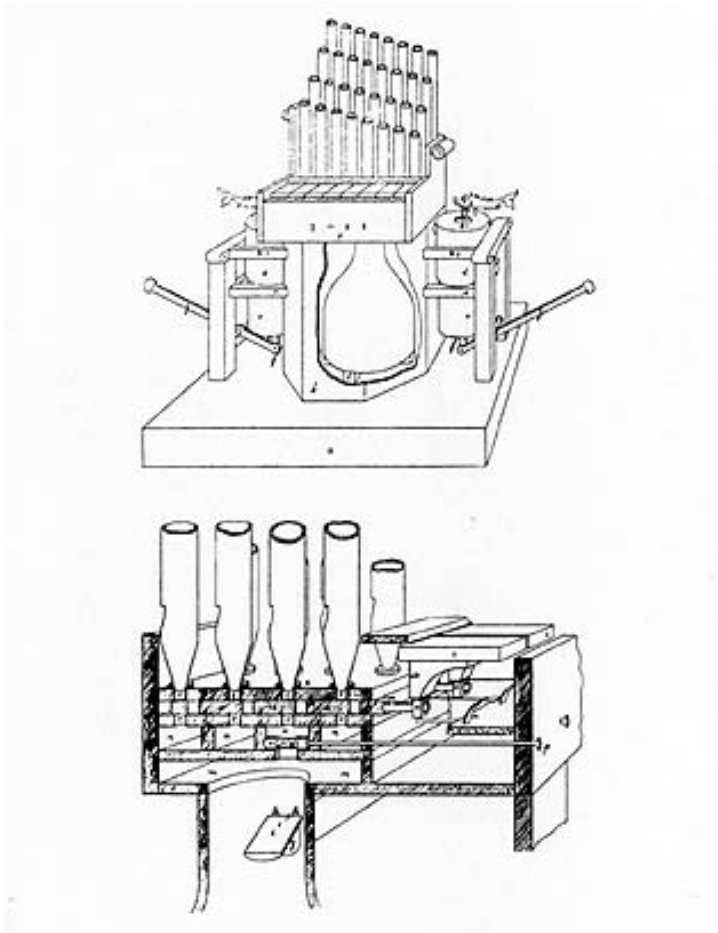
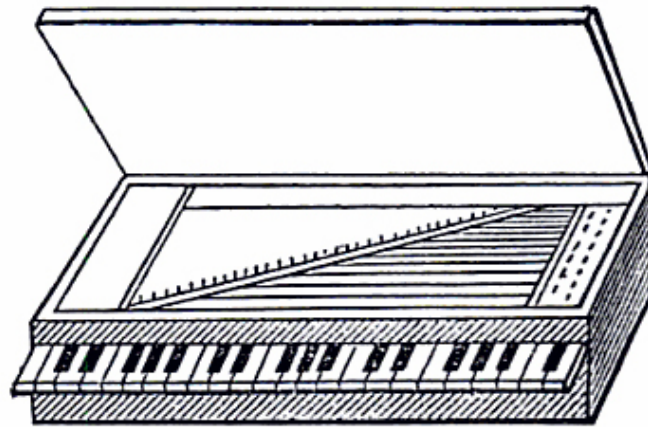

Figure 4
Hydraulis (drawing)
circa 100 B.C.

Image source: http://publishing.cdlib.org/ucpressebooks/data/13030/5f/ft0000035f/figures/ft0000035f_fig35.jpg



Clavicytherium, 14th Century

Figure 5

Clavicytherium (front perspective)

circa 14th century

The clavicytherium is a vertically mounted harpsichord produced in the 14th century. Its strings are arranged in the form of a triangle (harp form) and sounded by a pricking of a quill pleetra, fastened to the end of the clavis.

Image source: *Pianos and Their Makers: A Comprehensive History of the Development of the Piano From the Monochord to the Concert Grand Player Piano.*

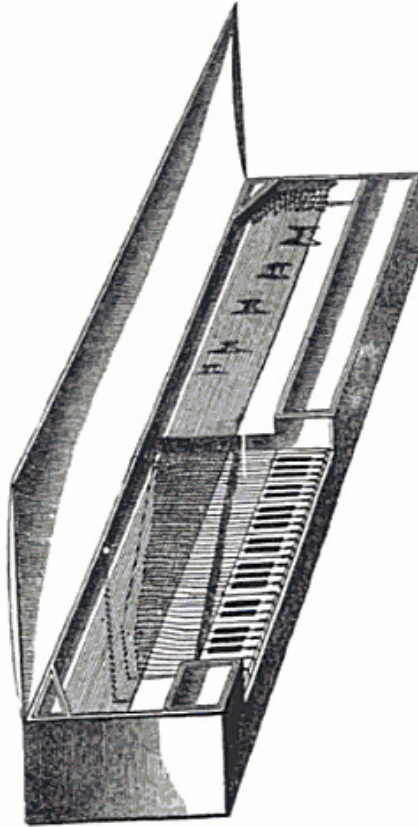

Clavichord, 16th Century

Figure 6
Clavichord (left perspective)
circa 16th century

The clavichord is a Medieval keyboard instrument consisting of 20 or 22 strings of brass, which were agitated by applying pressure to a tangent, brass pin flattened on top fastened to the clavis. The form is similar to the later square piano.

Image source: *Pianos and Their Makers: A Comprehensive History of the Development of the Piano From the Monochord to the Concert Grand Player Piano.*



Figure 7
Spinet (front perspective)
circa 1540

The spinet is a 16th century keyboard in an oblong form with of a compass of four octaves with long strings and a larger soundboard. Its construction allowed for a material increase in sound volume.

Image source: <http://www.metmuseum.org/Collections/search-the-collections/180014811>



Figure 8
Queen Elizabeth Virginal (front perspective)
circa 1594

The virginal is a small rectangular version of a harpsichord created and used in the late Renaissance and early Baroque periods. Utilising one string per note, it was often built without legs to be played on top of a table.

Image source: http://cnmat.berkeley.edu/event/2011/05/06/eigenharp_slabs_and_linnstrument_hands_three_new_musical_instrume



Figure 9

Reproduction of a 1620 Clavichord (front perspective)

circa 21st century

Reproduction of a 1620 Clavichord after *Michael Praetorius*. This instrument was produced by a German craftsman who makes reproductions of the early keyboard instruments.

Image source: <http://www.griewisch.com/englisch/instrumente/index.php>



Figure 10
Pipe Organ (front view)
1850

The pipe organ, which was first created in the 17th century, is a keyboard-controlled instrument which produces sound by blowing air through varying sized pipes. It produces a wide variety of timbres, but offers little dynamic control of individual notes.

Image source: <http://www.metmuseum.org/Collections/search-the-collections/180012258>



Figure 11
Harpsichord (right perspective)
1744

The Harpsichord is a keyboard instrument which produces a relatively loud sound, but offers less dynamic control over individual notes compared to the pianoforte.

Image source: <http://www.metmuseum.org/Collections/search-the-collections/180016455>



Figure 12
Harp (left perspective)
circa 1785

image source: <http://collections.vam.ac.uk/item/O58969/pedal-harp-cousineau-georges/>



Figure 13
Ancient Organ (drawing)
circa 1620

This is an image of the ancient mode of organ blowing from Praetorius's *Theatrum Instrumentorium* 1620.



Figure 14
Cathedral Organ (front perspective)
circa 14th - 15th Centuries

This is an image of the Bordeaux Cathedral Organ.

Image source: http://upload.wikimedia.org/wikipedia/commons/1/17/Bordeaux_Cathedral_organ.jpg



Figure 15
Clavichord (front perspective)
1763

Instruments became beautiful, prized items of luxury as the painting on the interior of this Clavichord shows.

Image source: <http://www.metmuseum.org/Collections/search-the-collections/180015040>



Figure 16

Bartolomeo Cristofori

1655 - 1731

The inventor of the pianoforte.

Image source: http://www.torgny.biz/images/Cristofori_portratt.jpg



Figure 17
Square Piano Forte (right perspective)
circa 18th century

The golden age of the piano occurred in the 18th century through the 19th century. Built on the physical design of its keyboard precursors, it offered greater dynamic control and was capable of producing loud sound and offers dynamic control of individual notes. While the pianoforte represented a huge step forward in terms of dynamics, it still has no continuous dynamic control in that it cannot create crescendo and vibrato during sustained notes. Thus, when playing the piano, it is necessary for the player to simulate crescendo and vibrato effects through hand techniques.

Image source: <http://www.metmuseum.org/Collections/search-the-collections/180015110>



Figure 18
Upright Piano (front perspective)
circa 1869

Image source: <http://collections.vam.ac.uk/item/O58870/piano-john-broadwood-sons/>



Figure 19
Yamaha A1L Baby Grand Piano (right perspective)
circa 2014

Image source: <http://www.petersmithpianos.com/wp-content/uploads/2011/07/Yamaha-A1L-Baby-Grand.jpg>



Figure 20
Da Vinci Piano (back perspective)
circa 2013

Image source: http://hotdigitalnews.com/wp-content/uploads/2013/11/Viola_610x358.jpg



Figure 21
Fluid Piano (left perspective)
circa 2010

Image source: http://www.artscouncil.org.uk/media/uploads/se_website_images/geoff-matthew-fluid-piano_jpg_576x262_crop_upscale_q85.jpg



Figure 22

Thomas Edison

1847 - 1941

Edison's invention of the phonograph changed the way we experience and relate to sound and music.

Image source: <http://www.menloparkmuseum.org/files/the-young-inventor-full.jpg>



Figure 23
Edison's Home Phonograph (front perspective)
1896

In 1878, Edison received a patent (200,521) for the phonograph, a recording and sound production machine which played a spinning cylinder with a piece of tin foil wrapped around it, with a 2-3 minute capacity. The phonograph is also referred to as the gramophone.

Image source: <http://memory.loc.gov/ammem/edhtml/home.jpg>



Figure 24
Theremin (left perspective)
circa 1918 - 1928

The Theremin was and is the most 'continuous' instrument of all time. This is a moog theremin.

Image source: http://www.etheremin.com/wp-content/uploads/2013/09/moog_theremin_standard-500x500-300x300.jpg

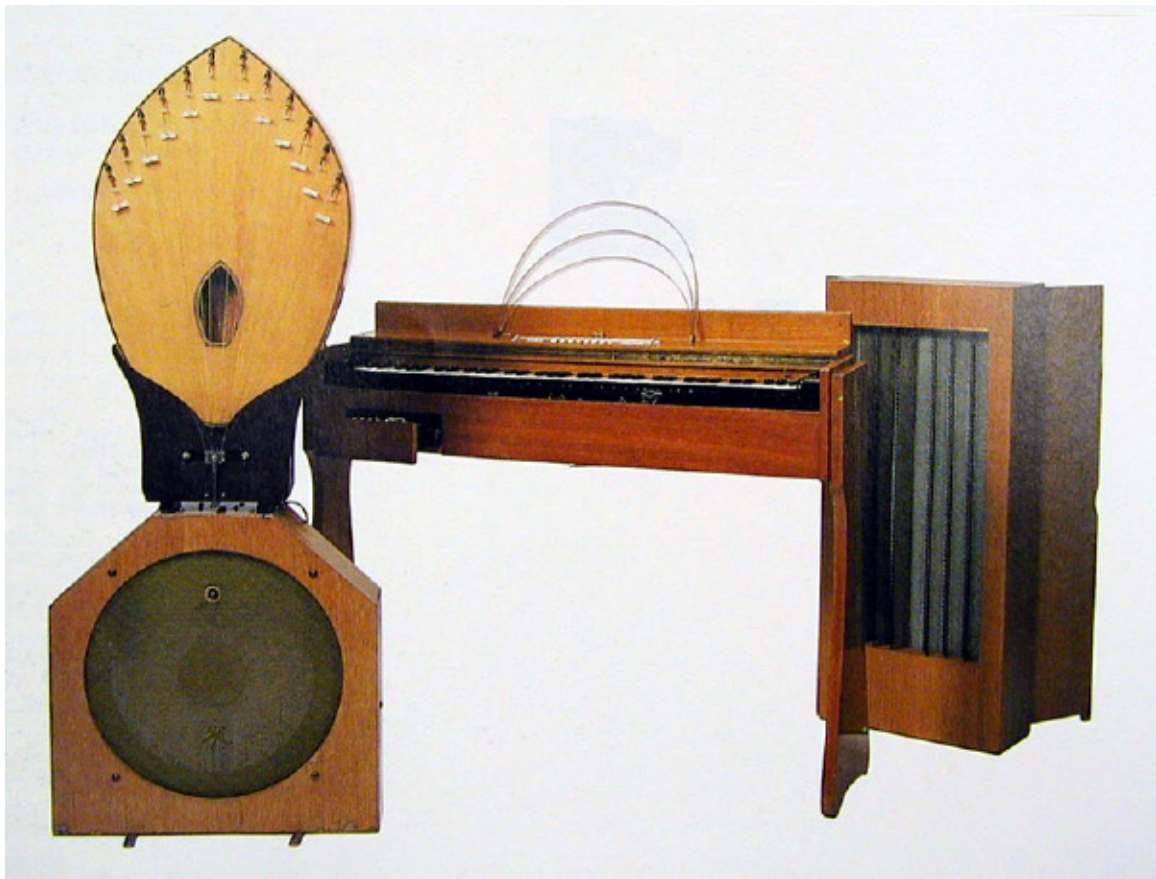

Figure 25
Ondes Martenot (front perspective)
circa 1928

The Ondes Martenot, created by Maurice Martenot in 1928, is one of the earliest electric keyboard instruments. It produces natural pitch bending and sounds which resemble those of a theremin. Later models were attached to loud speakers.

Image source: http://cafemusique.files.wordpress.com/2010/11/ondes_martenot-01.jpg



Figure 26

Ondes Martenot at the Paris World Fair (front stage view)

1937

Image source: <http://www.peterpringle.com/theremin%20jpegs/ondes6.jpeg>



Figure 27
Hammond Novachord (front perspective)
circa 1935

The Hammond Novachord was the first synthesizer to use subtractive synthesis. It was a polyphonic electronic organ that could play 72 notes and used 169 vacuum tubes with five frequency dividers per oscillator. The front of the instrument contained 14 analog rotary knobs to set the timbre, volume, resonance, bass, treble, vibrato, and brightness of the sound. It had 3 foot pedals to control the sustain and volume of notes. The Novachord was manufactured in the US from 1939-1942.

Image source: <http://scienceservice.si.edu/pages/088006.htm>



Figure 28
Novachord (left perspective)
circa 1939

Image source: http://waveformz.com/wp-content/uploads/2013/01/Novachord_insides3.jpg



Figure 29

Rhodes Army Air Corps Piano and Harold Rhodes (left perspective)
circa 1942-5

This is an image of Rhodes Army Air Corps Piano and Harold Rhodes. The Army Air Corps lap model piano was produced in 1942 and built through 1945. Similar to a xylophone, it was a twenty-nine-note keyboard made from aluminum tubing from a B-17.

Image source: <http://www.fenderrhodes.com/pianos/early.html>



Figure 30

Rhodes Pre-Piano (front perspective)

1946

Notice the curvature at the back - truly a baby grand piano.

Images source: http://cdn1.gbase.com/usercontent/gear/3026129/p2_uy0nvobsw_so.jpg

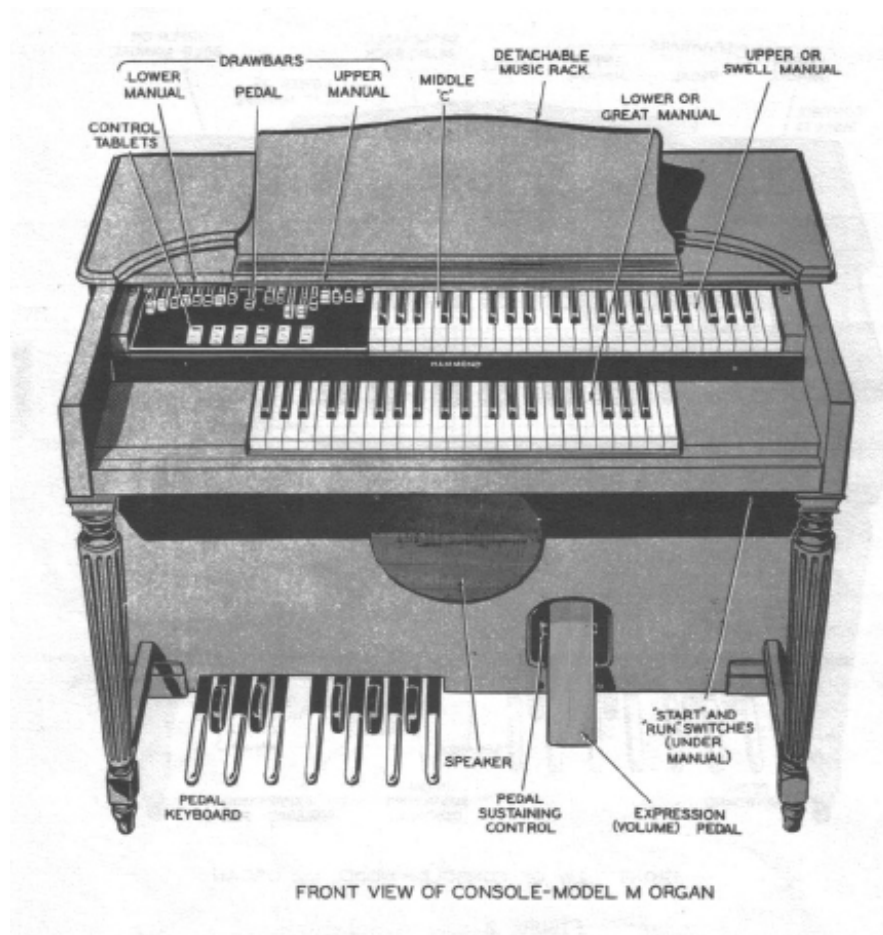

Figure 31
Hammond Organ
1948-51

This is the Hammond Organ Tone Generator Spinet Model M.

Image source: <http://www.organservicecompany.com/idorgan.html>



Figure 32
 Fender Piano Bass (front perspective)
 1959

Image source: <http://www.fenderrhodes.com/pianos/early.html>



Figure 33
Robert Moog
1934 - 2005

The most important sound innovator in the 20th century.

Image source: http://www.nationalturk.com/en/wp-content/uploads/2012/05/robert_arthur_bob_moog_google-doodle-nationalturk.jpg



Figure 34
Moog Modular Synthesizer (front perspective)
1964-81

The Moog Multiply-Touch-Sensitive Keyboard produces polyphonic after touch and glissando effects with the ability to measure pressure on across three axis on the keys. It is the product of research from the Moog Music, Inc. and the Indiana School of Music. For a timeline and description of each Moog Model from 1964 – 81 see: <http://www.vintagesynth.com/moog/modular.php>

Image source: <http://www.vintagesynth.com/moog/modular.php>



Figure 35

Hammond Organ Tone Generator X-66 (right perspective)

1967-73

Image source: <http://www.organservicecompany.com/idorgan.html>



Figure 36
Fender Rhodes Mark 1 Stage Piano (right perspective)
1969-75

The Mark 1 Stage Piano was a fantastic instrument. The electro-acoustic depth of expression makes the Rhodes a closer relative to the Seaboard than many synths and organs.
Image source: <http://www.fenderrhodes.com/pianos/mark1a.html>



Figure 37
Fender Rhodes Stage Piano (front perspective)
1967-75

This Fender Rhodes Stage Piano is seen here with self-amplifier.

Image source: <http://www.fenderrhodes.com/pianos/mark1a.html>



Figure 38
Moog Mini Moog (front perspective)
1970-82

The first truly portable, affordable synthesizer, the Mini Moog had a huge impact on popular music.

Image source: <http://www.vintagesynth.com/moog/moog.php>



Figure 39
Wurlitzer Orbit III (left perspective)
1971

An aunt of mine had a Wurlitzer Orbit at her house and I would play on it for hours each time I visited, exploring all the sounds and settings. As an object, it looks caught between a number of different worlds, like it hasn't quite found a home.

Image source: <http://www.vintagesynth.com/misc/wurlitzerorbit3.php>



Figure 40
Hammond 102200 (right perspective)
1974-75

By the 1970s, organs and synths were becoming more and more portable, like this 102200.

Image source: <http://www.vintagesynth.com/misc/hammond102200.php>



Figure 41
Yamaha CS-80 (front perspective)
1977-79

The CS-80 was the first great polyphonic aftertouch keyboard.

Image source: <http://www.vintagesynth.com/yamaha/cs80.php>



Figure 42
Sequential Circuits Prophet 5 (left perspective)
1978-84

The Prophet 5 was a programmable polyphonic analog synth, and, given that it was polyphonic, was one of the first devices that brought synths and keyboard closer to a union.

Image source: <http://www.vintagesynth.com/sci/p5.php>



Figure 43
Yamaha DX7
1985

One of the most famous and successful keyboards of all time, the DX7 brought frequency modulation synthesis to keyboards.

Image source: <http://www.vintagesynth.com/yamaha/dx7.php>



Figure 44
Kurzweil K250 (front perspective)
1984-90

The K-250 was the first sample-based electronic instrument.

Image source: <http://www.vintagesynth.com/kurzweil/k250.php>



Figure 45
Clavia Nord Lead (front perspective)
circa 1995

The Nord lead introduced a new and stylish, great-sounding, well-made line of instruments to the marketplace.

Image source: <http://www.vintagesynth.com/clavia/nord.php>



Figure 46
Nord Rack 2X Virtual Analogue (top view)
circa 1995

When an interface has many dials on it, each has to be labelled.



Figure 47
Nord Rack 2X Virtual Analogue (right perspective)
circa 1995

Dials are not inherently unattractive, but they also do not feel physically welcoming.



Figure 48
Nord Rack 2X Virtual Analogue (left elevation)
circa 2010

Most contemporary musical hardware has a rough-and-ready quality to it—notice the exposed screws in this side detail.

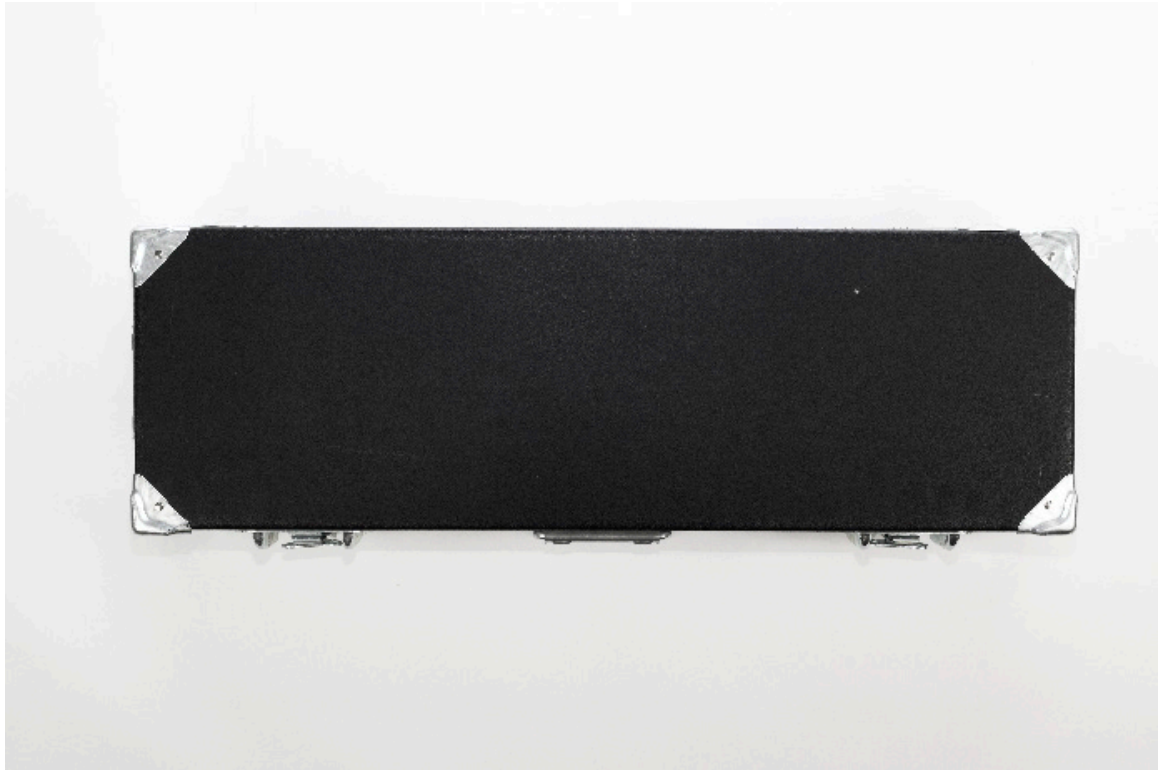

Figure 49
Haken Continuum case (top view)
circa 1998

Casing is an extremely important consideration with any instrumental design, as most musicians will want to transport their instruments.

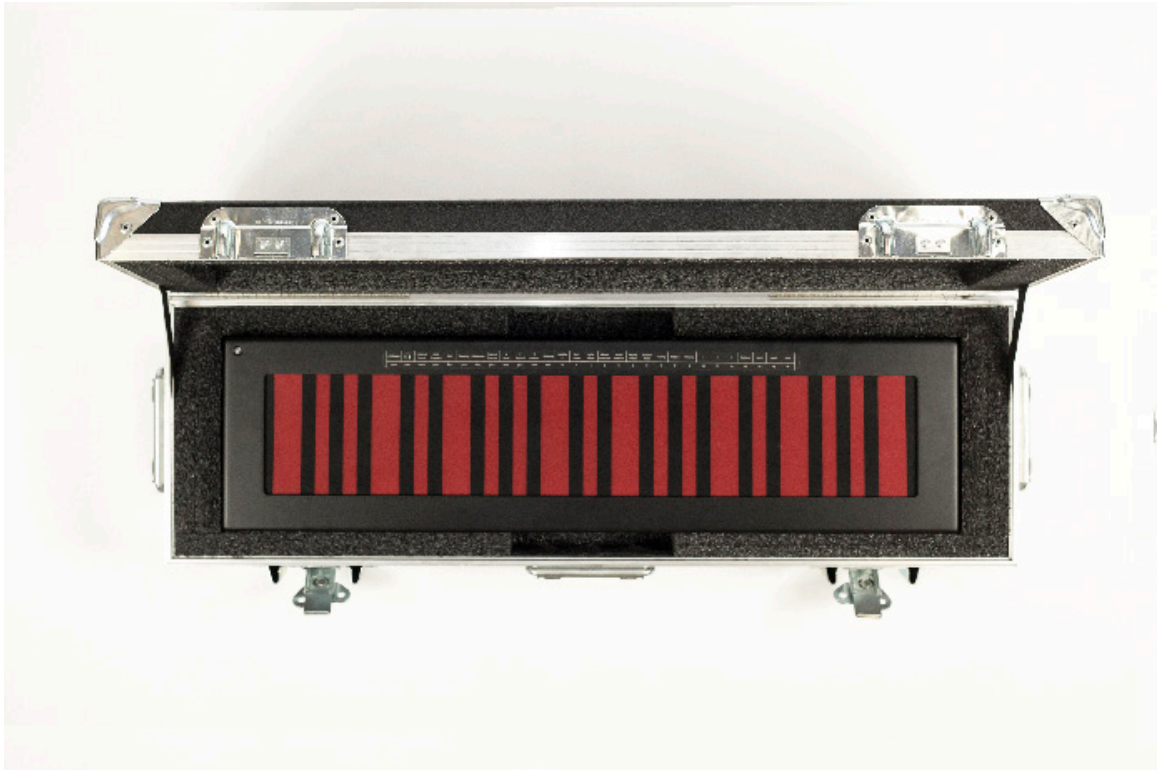

Figure 50
Haken Continuum open case (top view)
circa 1998

When you first see the Continuum, you notice the asymmetry of the sets of two and three strips of black, similar to a piano's black keys.



Figure 51
Haken Continuum (top view)
circa 1998

The Continuum has a simple, sturdy aluminum casing.



Figure 52
Haken Continuum (right perspective)
circa 1998

The playing surface of the Continuum feels nice, like neoprene. You can somewhat feel the Hall sensors underneath and playing creates a small amount of acoustic mechanical noise.



Figure 53
Haken Continuum (side perspective)
circa 1998

The Continuum has several inputs as shown here.



Figure 54
Haken Continuum (side elevation)
circa 1998

It runs an on-board sound engine with an excellent range of sounds.

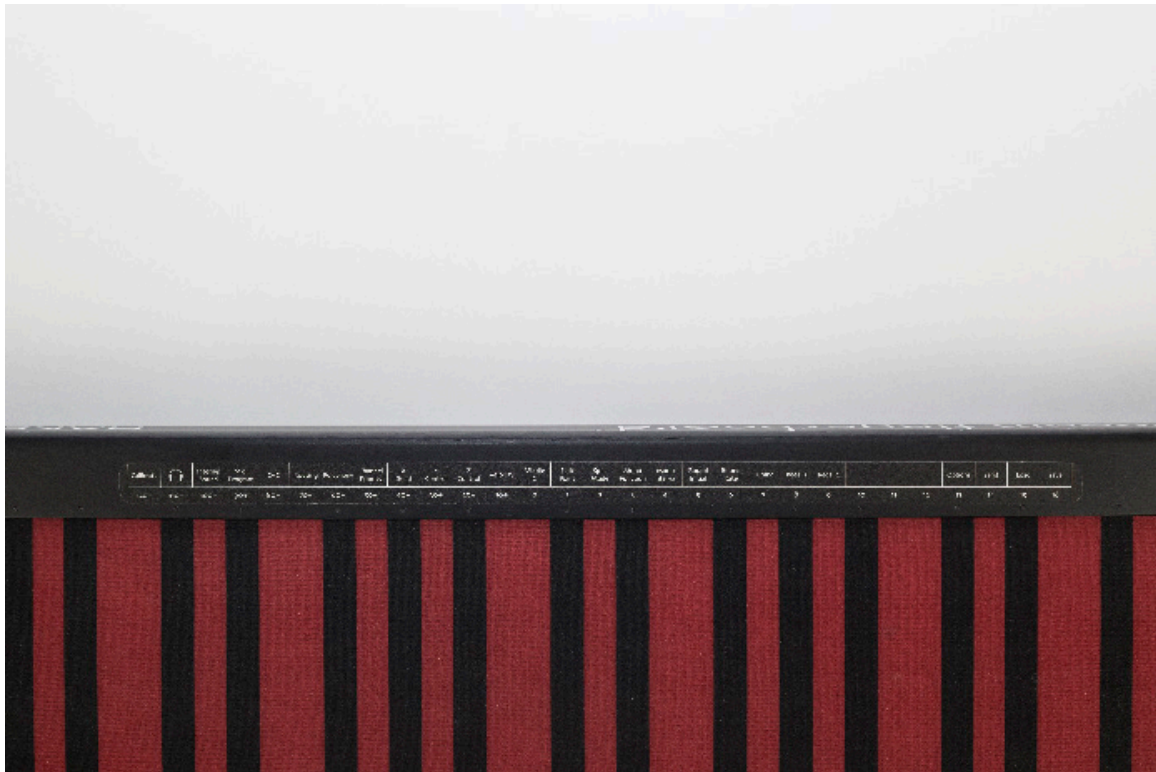

Figure 55
Haken Continuum key top (top view detail)
circa 1998

The Continuum does not have exterior controls, but rather a set of commands that can be accessed via the playing surface.

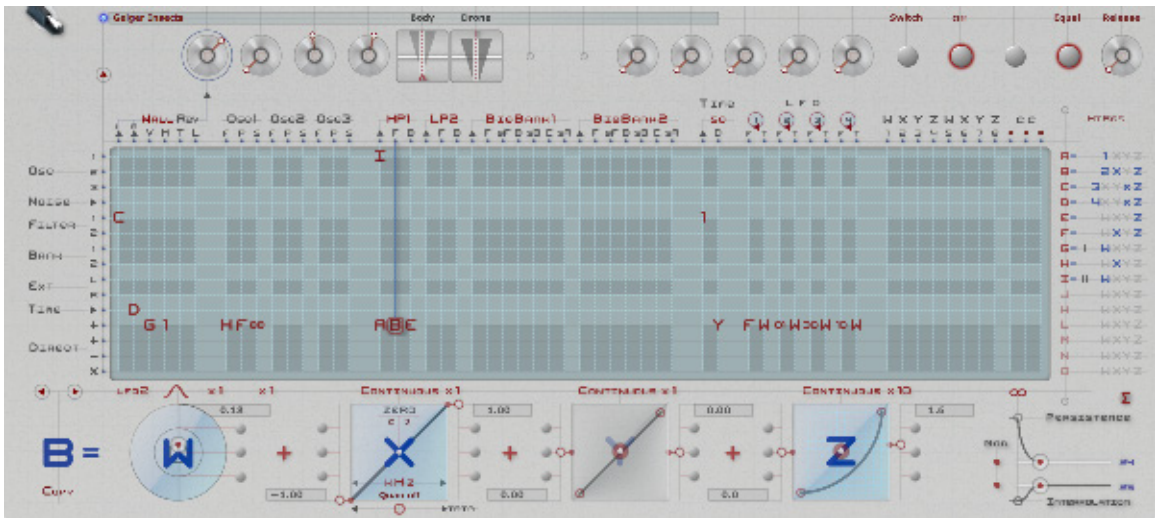

Figure 56
 Eagan Matrix (screenshot)
 circa 2013

The Eagan Matrix is a powerful synth, one of the best sound engines for multi-dimensional controllers. The mapping system is powerful though sometimes hard to learn.

Image source: <http://www.hakenaudio.com/Continuum/Resources/Screen%20Shot%202012-04-19%20at%204.41.26%20PM.png?329>



Figure 57
Reactable Live (front perspective)
circa 2003

The reactTable is a landmark tangible user interface for music, physicalising a complex process.

Image source: <http://www.reactable.com/products/live/order/>

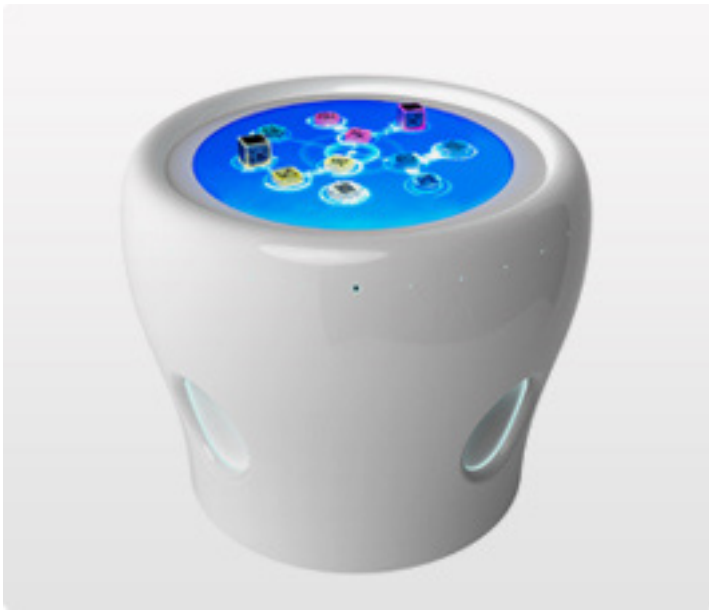

Figure 58
Reactable by MOS "Luxury" Design (front perspective)
circa 2000s

This presents an interesting perspective on what a modern musical instrument might look and feel like.

Image source:<http://www.reactable.com/products/by-mos/>



Figure 59
Reactable Mobile UX (screen view)
circa 2010

Ironically, for an interface based on physicalisation as a key principle, the app version has been its most popular output.

Image source: <http://www.reactable.com/products/mobile/>



Figure 60
Hecscan Rollup Piano
circa 2004

The Hecscan Rollup Piano is a light and flexible keyboard.

Image source: <http://www.dansdata.com/rup.htm>

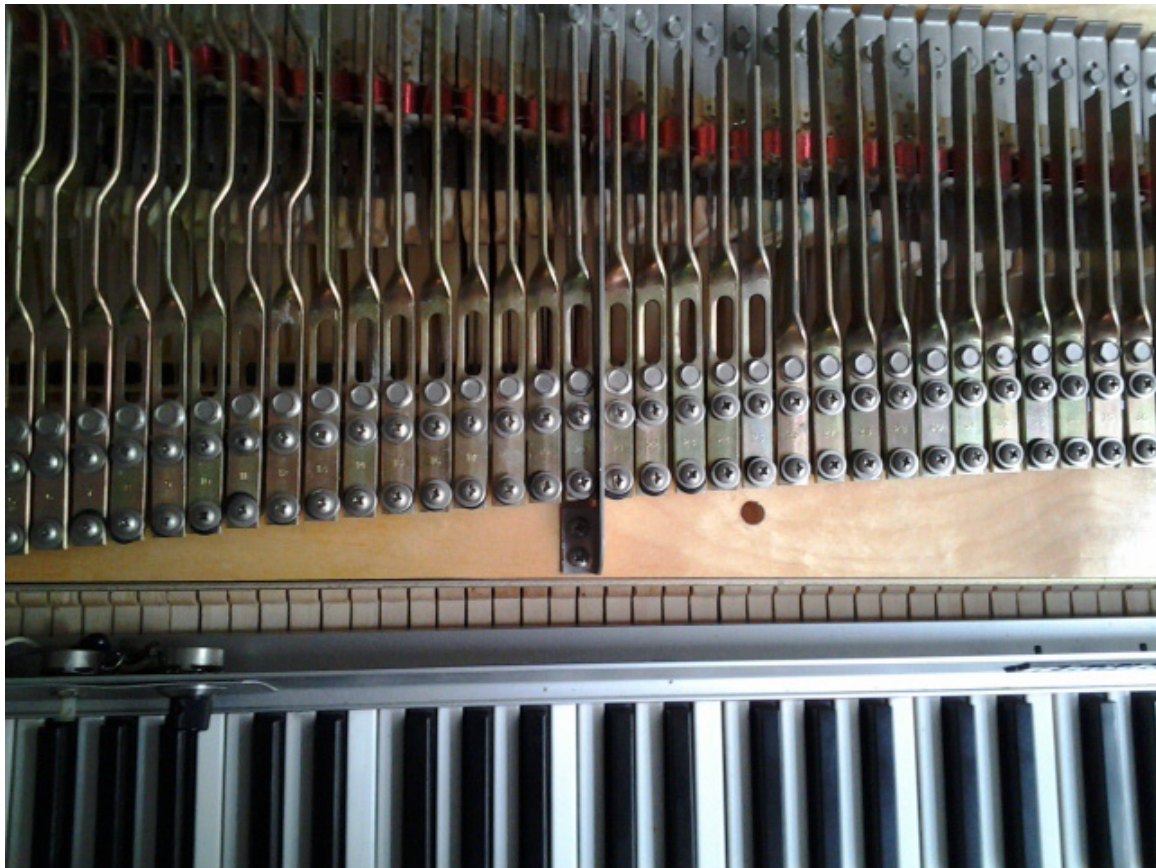

Figure 61

Electromagnetically sustained Rhodes Piano (top view detail)

circa 2011

The Electromagnetically sustained Rhodes Piano is a keyboard interface which allows live performance control of music playing and extension of the standard piano techniques with an interface that retains the original functionality of the instrument. It retains the capacities of the earlier Fender Rhodes Piano with the addition of control over the amplitude envelope of individual notes. It functions similarly to the EBow, a device designed to sustain the vibrations in ferromagnetic guitar strings through positive feedback.

Image year: <http://chicagoelectricpiano.com/wp-content/uploads/2015/02/2012-08-10-16.43.19.jpg>



Figure 62
Arp 26000 (front perspective)
1971-1980

This image and the next effectively show the tendency towards software replication of hardware.

Image source: <http://www.vintagesynth.com/arp/arp.php>



Figure 63

Arturia ARP 2600V (screenshot)

2004

Image source: <http://www.vintagesynth.com/misc/2600v.php>



Figure 64
Bosendorfer 290 SE Recording Piano (right perspective)
circa 1984-1986

The 290 SE Recording Piano or Imperial Bösendorfer is an electromechanical keyboard. Bosendorfer built a concept model in 1982 and released a later product version to market in 1984. It employs electromechanical and computer technology to expand the traditional piano instrument and performance technique by providing high quality gesture recording and playback. The instrument detects piano keys and pedal movements using a system of optical sensors consisting of LED's, phototransistor, and aluminum shutters underneath each key and hammer, records those movements, and stores the data on a disk or tape for editing and mechanical playback. For playback, Stahnke designed the system of adaptive calibration which uses a system of linear motor drive electronics attached to each key and pedal to calibrate itself to match playback velocities to those measured during recording. This system optimizes the performance of the motors and sensors, so that they do not interfere with the player during the initial performance.

Image source: http://www.boesendorfer.com/boesendorfer_en/uploads/web/BSD_



Figure 65
CEUS Bosendorfer (right perspective)
2006

Image source: http://www.boesendorfer.com/boesendorfer_en/uploads/web/BSD_ceus-master_001.jpg



Figure 66
Magnetic Resonator Piano (top perspective)
circa 2009

Image source: <http://andrewmcperson.org/research.html>



Figure 67

Infinite Response VAX77 MIDI Keyboard (front perspective)

2009

A contemporary aftertouch keyboard.

Image source: <http://www.infiniteresponse.com>

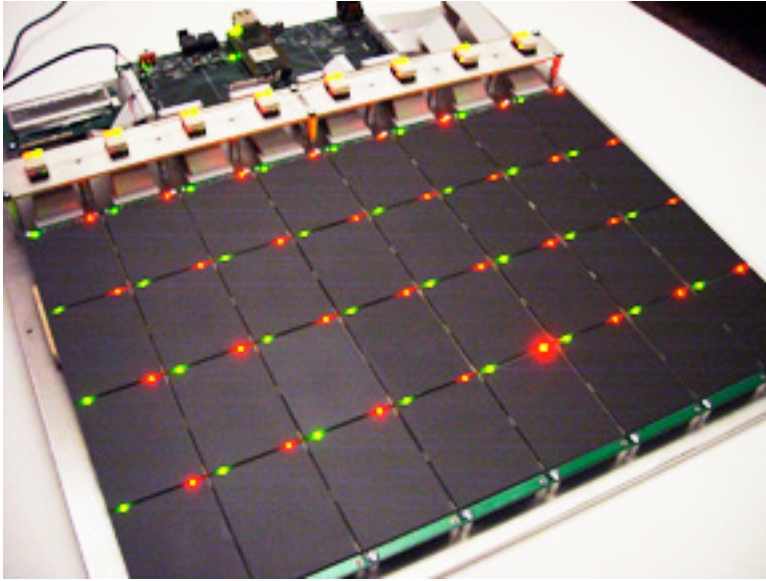

Figure 68
SLABS (top perspective)
circa 2009

SLABS is a highly expressive pressure-based percussive instrument.

Image source: http://cnmat.berkeley.edu/event/2011/05/06/eigenharp_slabs_and_linnstrument_hands_three_new_musical_instrume



Figure 69
Hyperkeys (right perspective)
circa 2010

Image source: Jordan Rudess performing on <http://www.youtube.com/user/Hyperkeys>

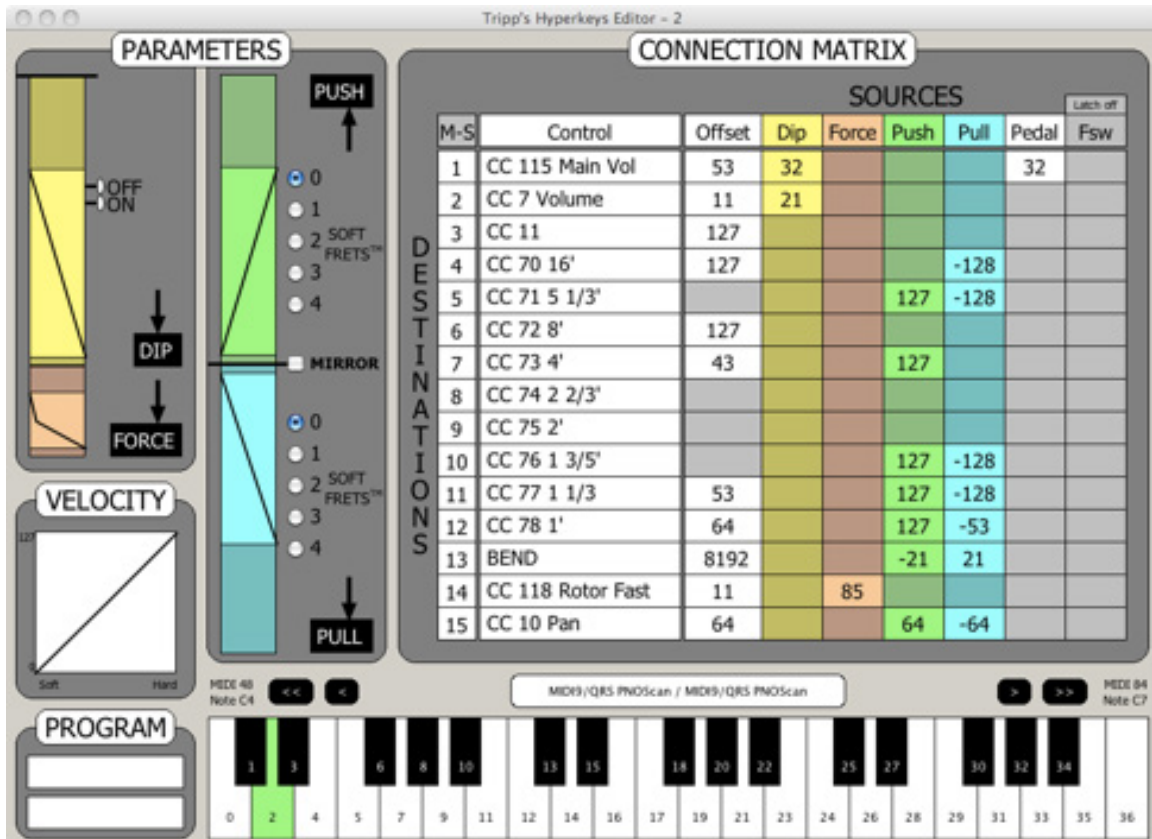

Figure 70
Hyperkeys 3D music editor GUI (screenshot)
circa 2000s

The HyperKeys GUI illustrates how difficult it is to come up with an elegant design when there is no clear conceptual model to build on in the background.

Image Source: http://www.hyperkeys.com/Hyperkeys/Blog/Entries/2011/4/29_The_Organ_Thing.html



Figure 71

Novation Mininova Synthesizer PP unit (front elevation)

circa 2012

Notice the size of the dials relative to the size of the whole instrument.



Figure 72
Novation Mininova Synthesizer PP unit (left elevation)
circa 2012

Wooden side panels are still a popular choice even for many contemporary instruments.



Figure 73
Touchkeys (top view)
January 2014

This TouchKeys has been installed in a LMK2+, which uses a flight case for its body.



Figure 74

Touchkeys (back elevation)

January 2014



Figure 75
Touchkeys without topcase (top view)
January 2014



Figure 76
Touchkeys (right perspective)
January 2014



Figure 77
Touchkeys (top view)
January 2014

Notice the patterning on the keys.

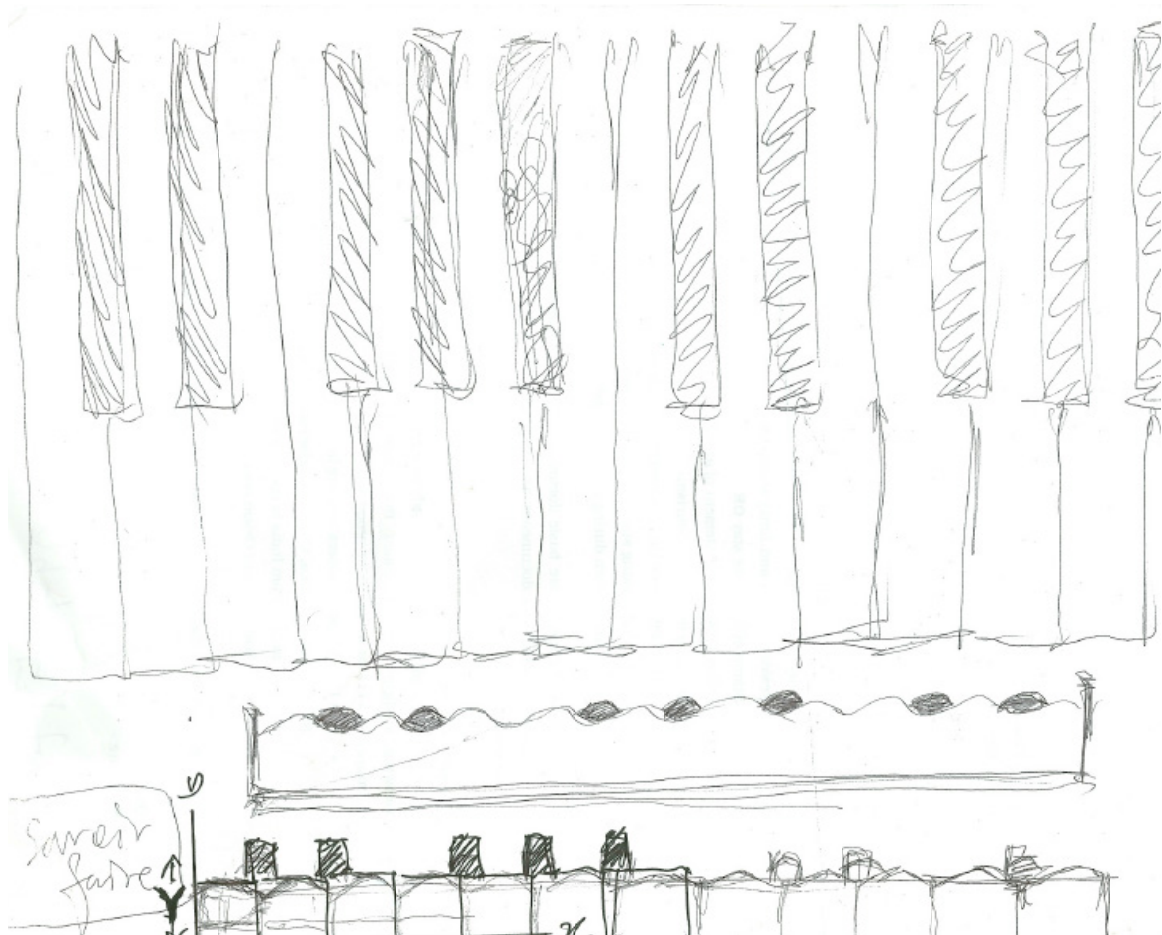

Figure 78

Continuous keywave concept design

January - May 2009

This is the first Seaboard concept design sketch. The wavy horizontal profile line on the top sketch presents the idea of a continuous contour keywave in contrast to the discrete volume blocks separated by vertical lines below.



Figure 79

Key volume concept design

January - May 2009

This is the first Seaboard concept design sketch presenting the 3D volume of the key-waves.



Figure 80

Key volume glissando concept design

January - May 2009

Another first sketch of the Seaboard.

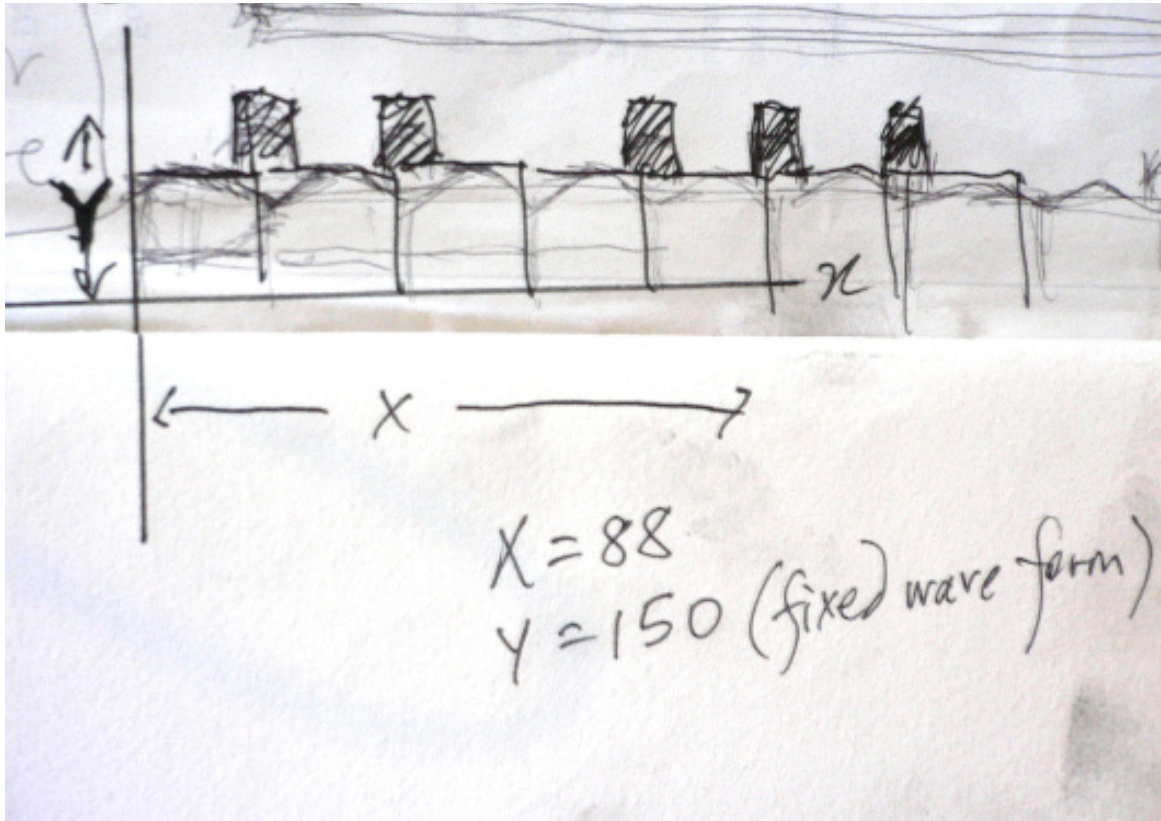

Figure 81

Dual-axis concept design

January - May 2009

This sketch presents the idea of a dual input axis, one horizontal and one vertical.

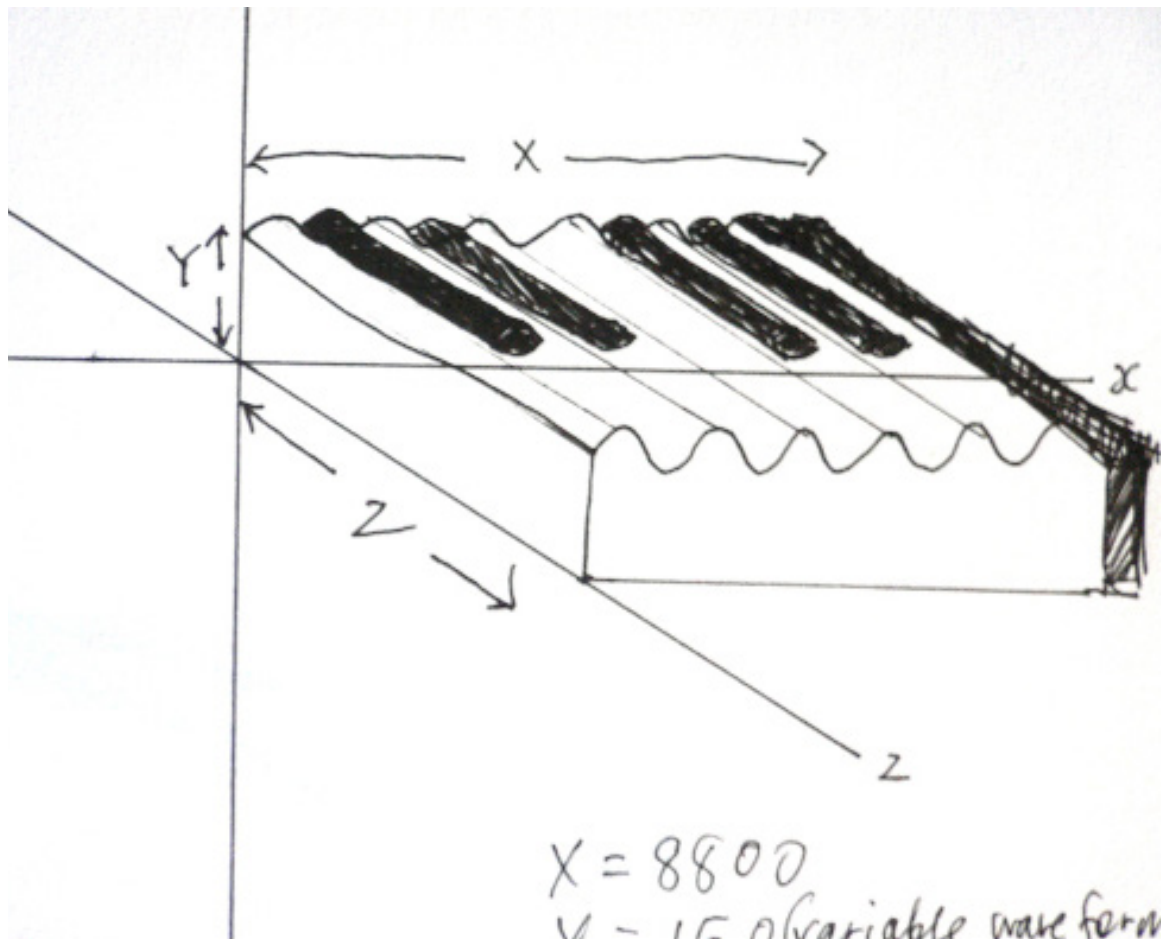

Figure 82
Tri-axis concept design
January - May 2009

What is marked as the y-axis in this sketch I now call the z-axis (i.e. downward pressure)

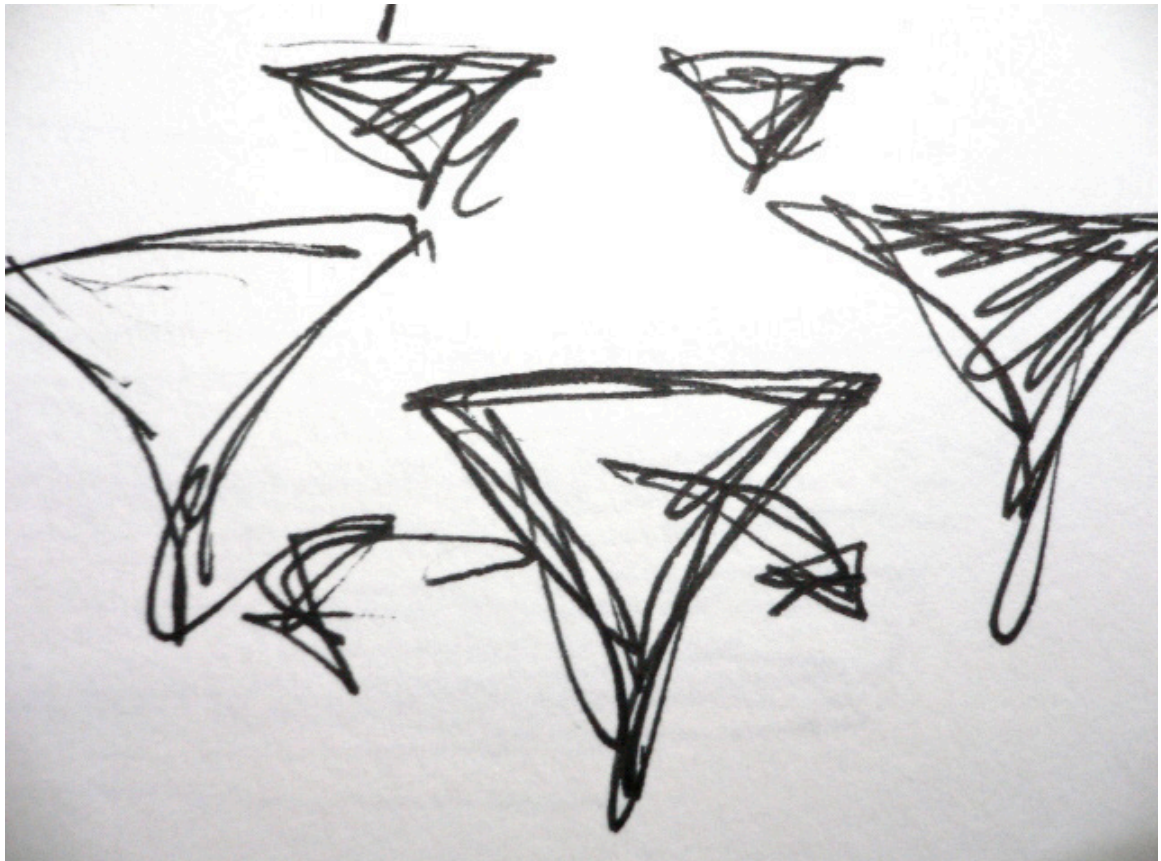

Figure 83

Mechanical pitchbending concept design

January - May 2009

This sketch represents a front view of a D being depressed, and then being able to move left or right.

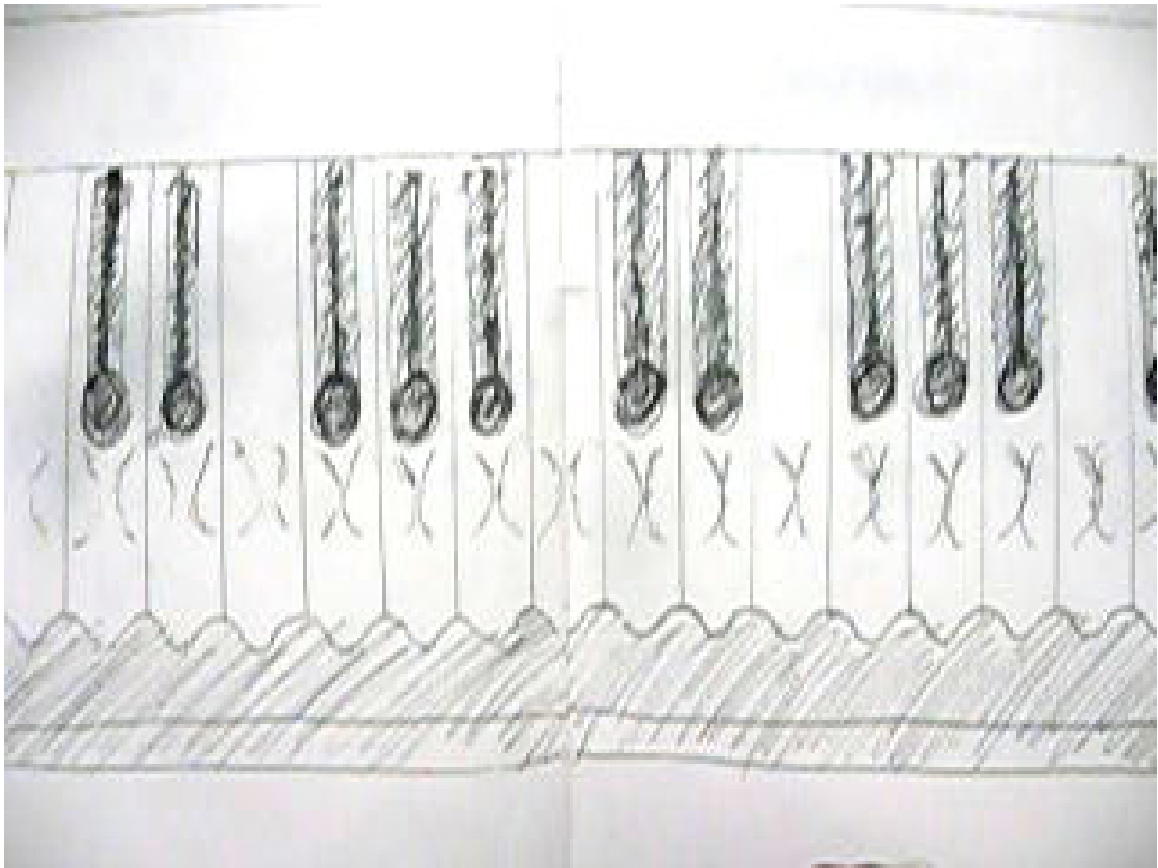

Figure 84

Key interface concept design

January - May 2009

See also key interface concept video.

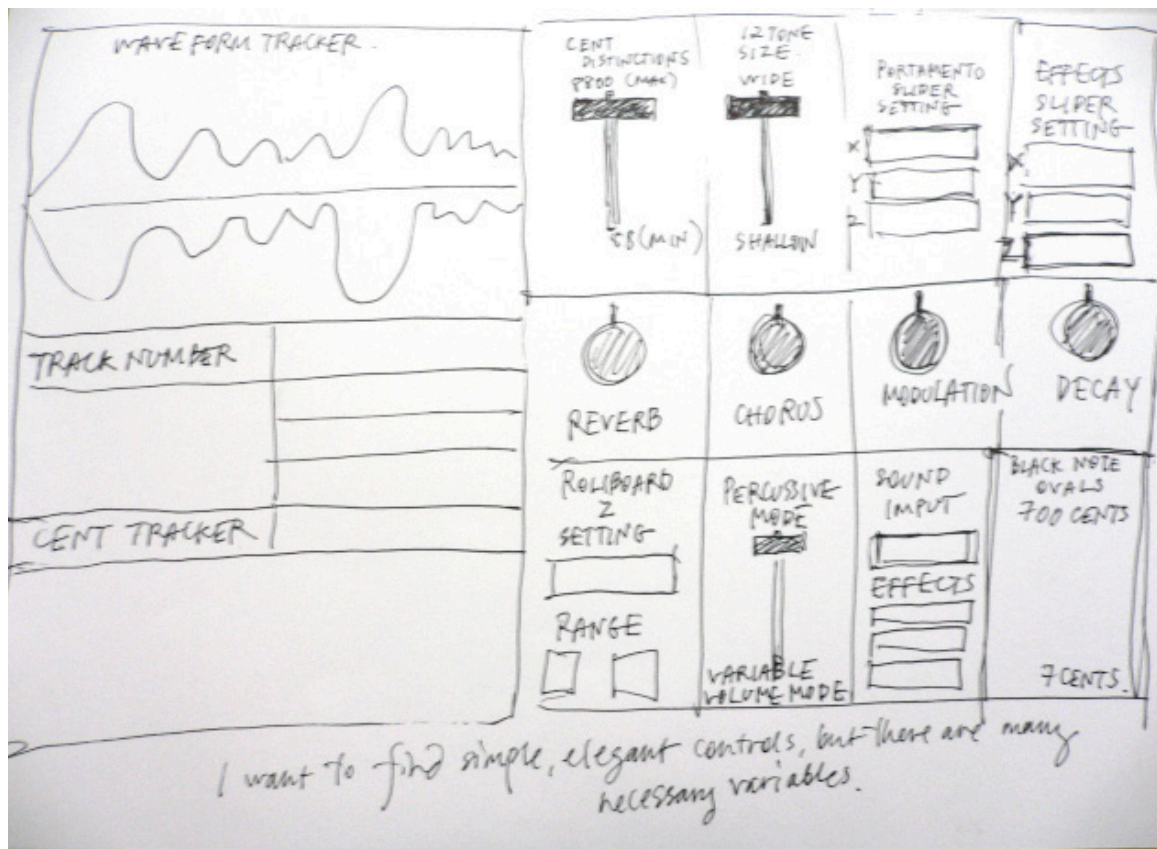

Figure 85

GUI concept design

January - May 2009

This is the first sketch of the functional controls to be displayed in the Seaboard graphical interface. This GUI envisions graphic digital versions of conventional hardware-operated audio controls such as reverb, chorus, modulations, and decay.

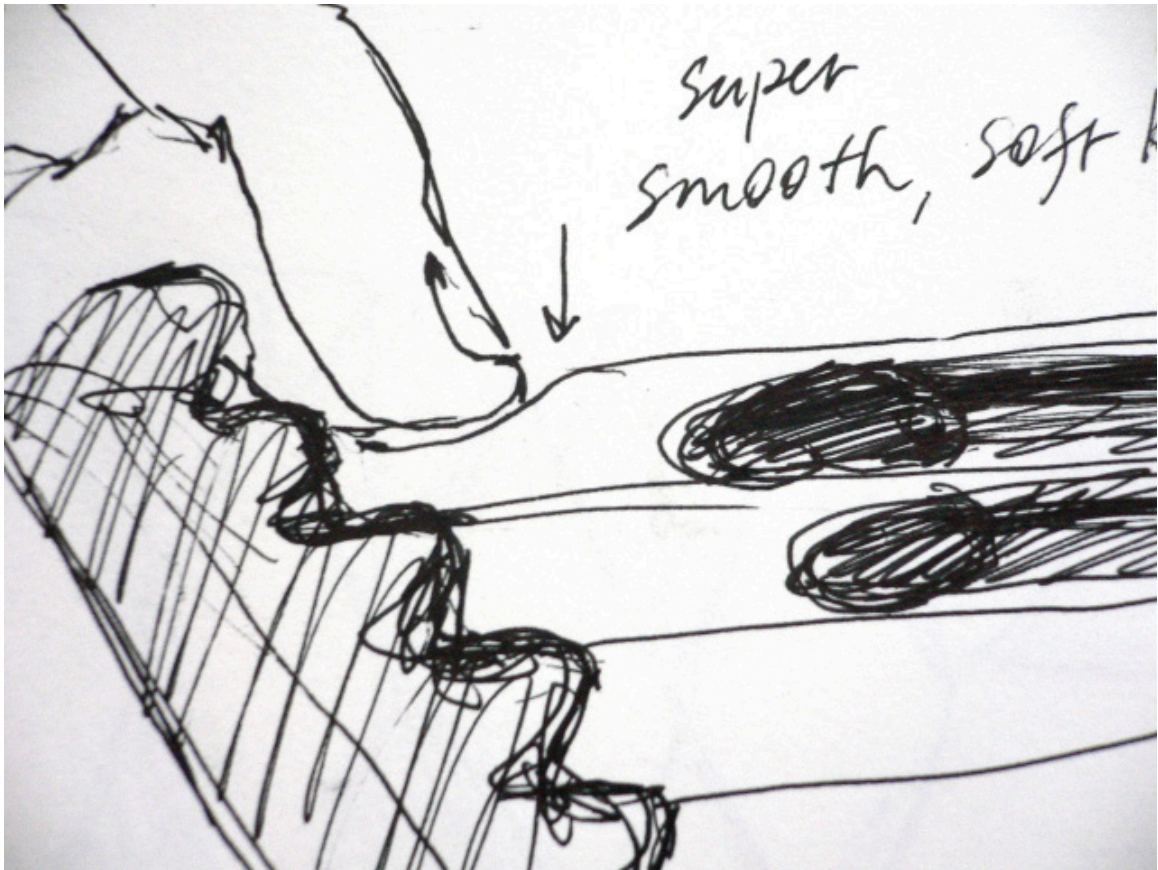

Figure 86

Soft surface keyboard interface idea (right perspective)

January - May 2009

This sketch presents the idea of the Seaboard interaction gesture, a finger pressing a "super smooth, soft" surface. The finger creates an impression on the key.



Figure 87

Silicone sample concept design (top view)

January - May 2009

These samples were developed to try the initial feel of a finger pressing a soft, elastic surface.



Figure 88
Silicone research samples (right perspective)
January - May 2009

These samples were cast to test material and surface qualities.



Figure 89
Silicone research samples (right perspective detail)
January - May 2009



Figure 90
Pointed key volume design trial clay mold (top view)
January - May 2009

This is the first keywave prototype mold. It is a relief made with a chisel and fingers. The keys have pointed ends.



Figure 91

Pointed key volume design trial clay mold (right perspective)

January - May 2009

Here I explored flat tops for the keys to improve playability.



Figure 92
Rounded key volume design trial clay mold (top view)
Month Year

This is the second prototype of the key shape. The key volume is rounded out. The mid-points are slightly thicker, and the shapes recall the lines of a violin or cello.

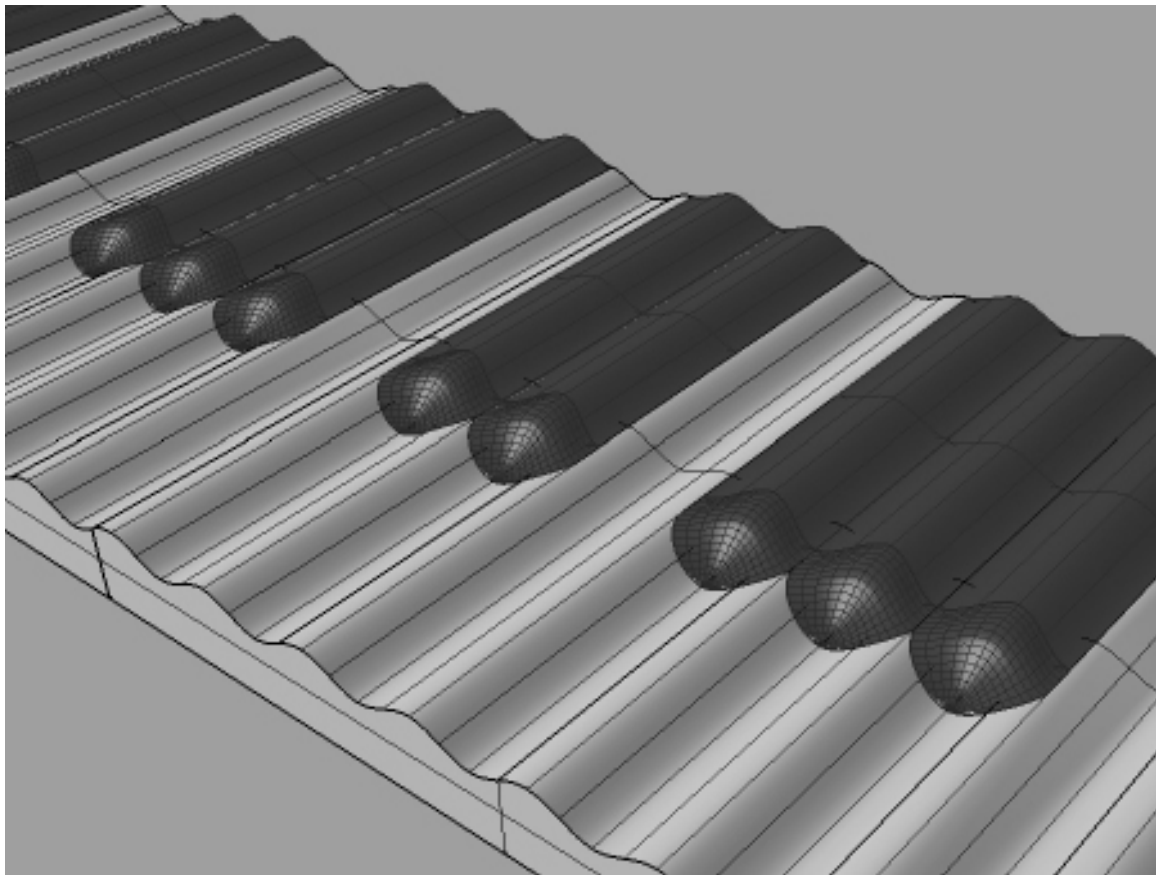

Figure 93
Seaboard 1 keywave CAD drawing (right perspective)
April - July 2009

This was a first CAD model before integrating ribbons.



Figure 94
Curved piano design
circa 20th Century

Image credit: Andrew MacPherson

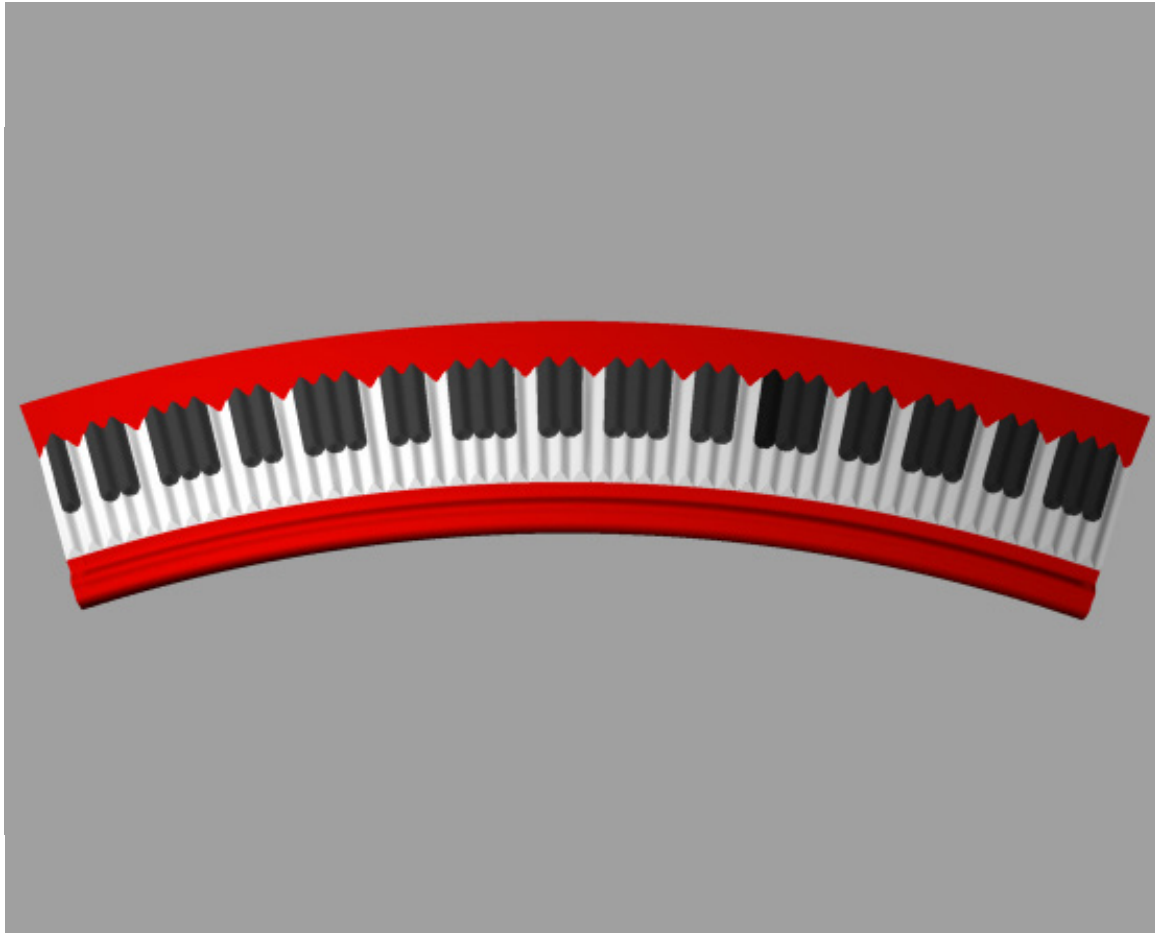

Figure 95

Seaboard 1 CAD rendering (top view)

April - July 2009

The first Seaboard prototype was seven octaves and curved towards the player.



Figure 96

Seaboard 1 key volume CAD rendering (left perspective detail)

April - July 2009

The lower glissando ribbon is separated into two troughs, one narrower concave for general sliding and a lower body for pushing one's palm against.

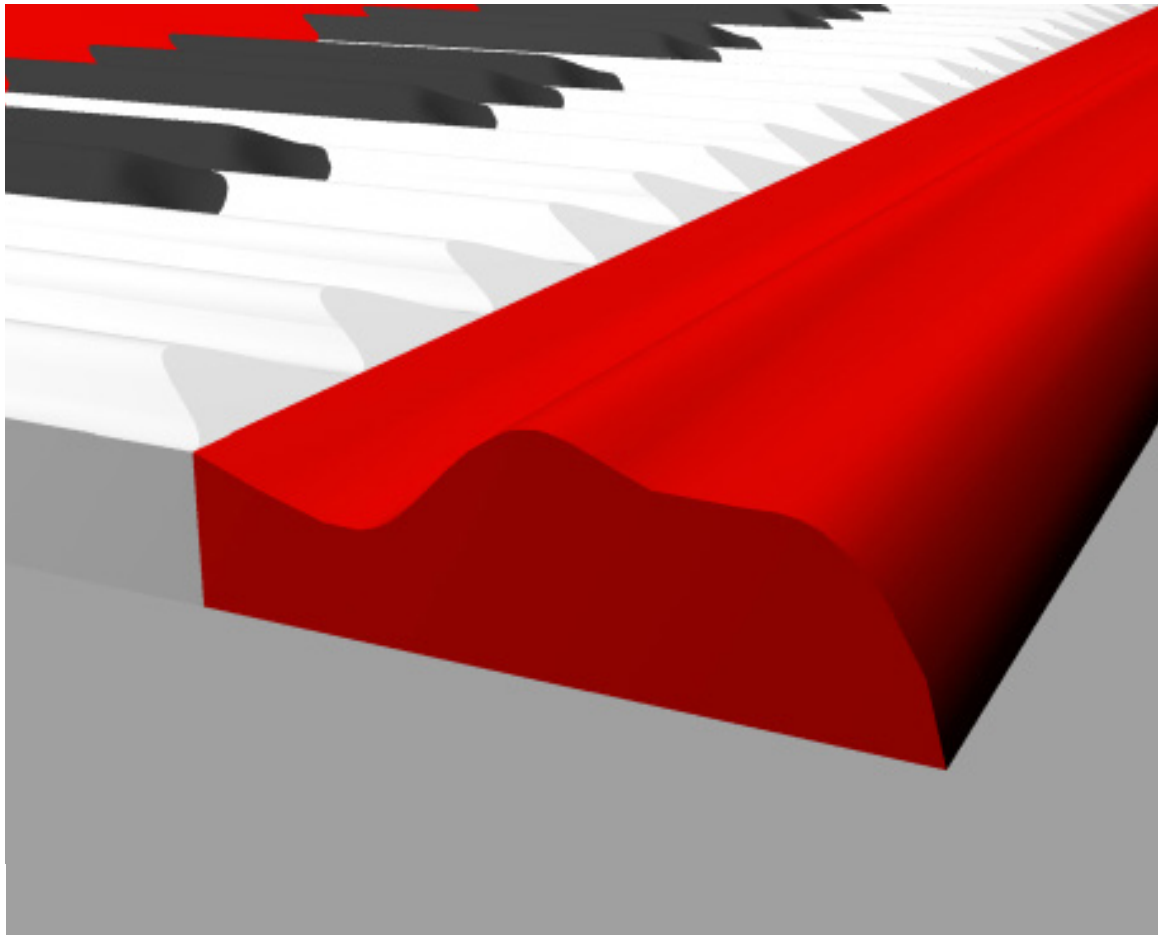

Figure 97

Seaboard 1 key volume CAD rendering (left perspective detail)

April - July 2009

The palm pad felt good, but seemed like an unnecessary feature.



Figure 98

Seaboard 1 rendering (right perspective)

April - July 2009

A first rendering of the Seaboard surface with its case.



Figure 99
Seaboard 1 key ribbon casting (right perspective)
April - July 2009

The Seaboard 1 being cast.



Figure 100

Seaboard 1 partial cast (left perspective)

April - July 2009

This is an example of a casting error. There are air bubbles trapped in the cured silicone. Air bubbles result from uneven liquid mixture and pouring. Air bubbles are problematic for Seaboard playing because they create uneven material consistencies which create unpredictable pressure mapping.



Figure 101

Seaboard 1 cast trial (left perspective)

April - July 2009

The Seaboard 1 was produced at the RCA. All Seaboard prototypes from the Seaboard 1 to the GRAND LFE are cast and removed as one body. However, the recipe has evolved prototype to prototype in order to refine material properties such as hardness, touchback, elasticity, consistency, smoothness, and surface textures.

Seaboard 1's key visual mimicked the piano key shades, white main body keys with black sharp and flat keys. The glissando ribbon is cast in black to distinguish it from the main body keys. The cast above has a visual defect on the bottom left key range. The black pigmented silicone has run into the white body.



Figure 102

Seaboard 1 keys (left perspective detail)

April - July 2009

This was the first beautiful picture of a Seaboard, and shows the surface shape in some detail.



Figure 103

Seaboard 1 (top view)

April - July 2009

The Seaboard Concept Prototype is the first realized 3D form-factor design. It is not a functional prototype in that it does not produce sound. It is designed to resemble the form factor of a curved piano with white main and black sharp and flat keys.



Figure 104

Seaboard 1 (front elevation)

April - July 2009

The height of the chassis is greater than that of the keys. Starting with LUTE D, the chassis was minimized to emphasize the playable input surface.



Figure 105

Seaboard 1 (left perspective)

April - July 2009

The image demonstrates the expressionist style design language. The curvature of the chassis bends towards the player's body. The arched body shape resembles the curved surface contour of each keywave.



Figure 106
Seaboard 1 and generic stand (right perspective)
April - July 2009



Figure 107
Seaboard 1 and generic stand (left perspective)
April - July 2009



Figure 108

Seaboard 2 sample cast (top view)

July 2009 - January 2010

This is an all-black cast of the Seaboard 2.

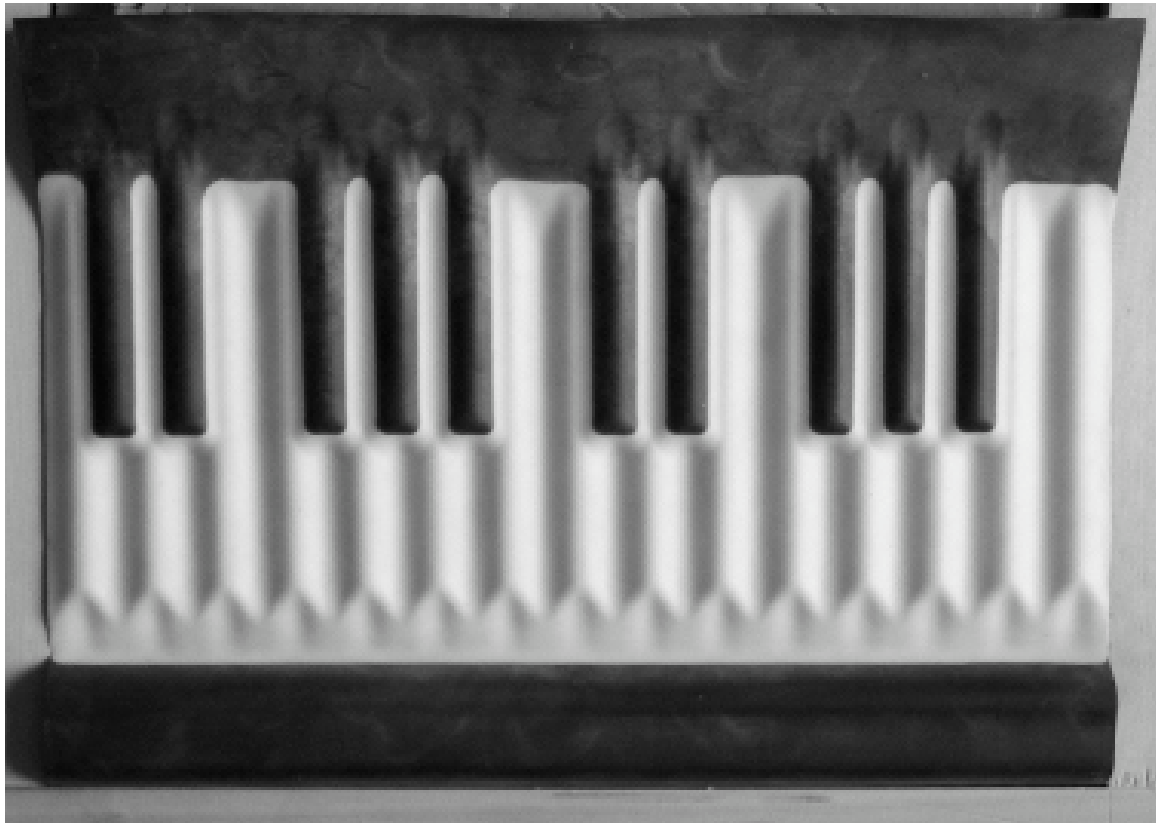

Figure 109

Seaboard 2 cast (top view)

July 2009 - January 2010

This is a standard black-and-white cast of the Seaboard 2.

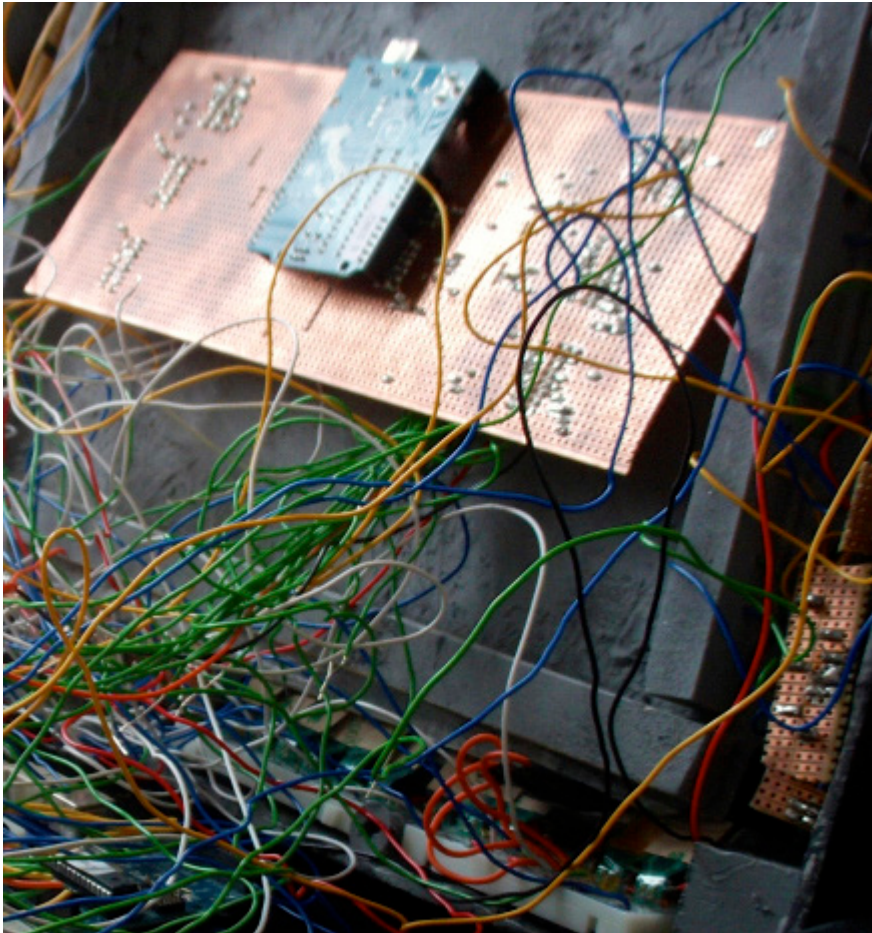

Figure 110
Seaboard 2 internal electronics (right perspective)
July 2009 - January 2010

The first working prototype was constructed by hand. The Seaboard LFE electronics are custom designed, but their production is outsourced to an electronic manufacturer. The number of electrical connections over the course of the Seaboard prototypes have been significantly reduced to a set of 7 wiring assemblies for the Seaboard GRAND LFE and GRAND Stage and 5 for the GRAND Studio.



Figure 111

Seaboard 2 and case (video screen shot)

July 2009 - January 2010

The Seaboard 2 was an effective technology demonstrator. See Video 06.



Figure 112

Seaboard 2 sensor alignment (front perspective)

July 2009 - January 2010

The bends in these sensors created a small amount of sensor noise.



Figure 113
Seaboard 2 sensor alignment (left perspective)
July 2009 - January 2010

The chassis was cast as a single body and the holes for the sensors were drilled out and then filed.

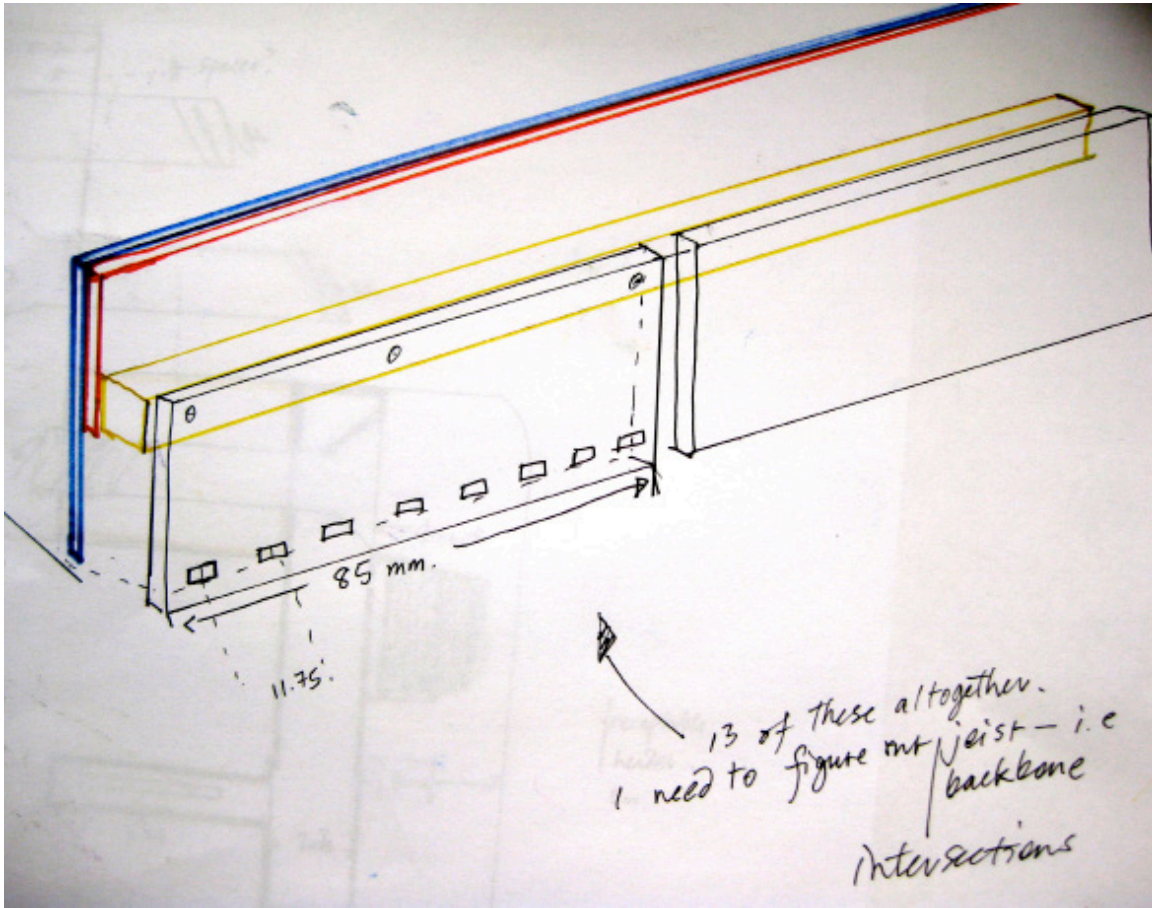

Figure 114

Seaboard 3 chassis inner panel (design)

February - September 2010

With the Seaboard 3, PCBs were printed and their placement was carefully considered.

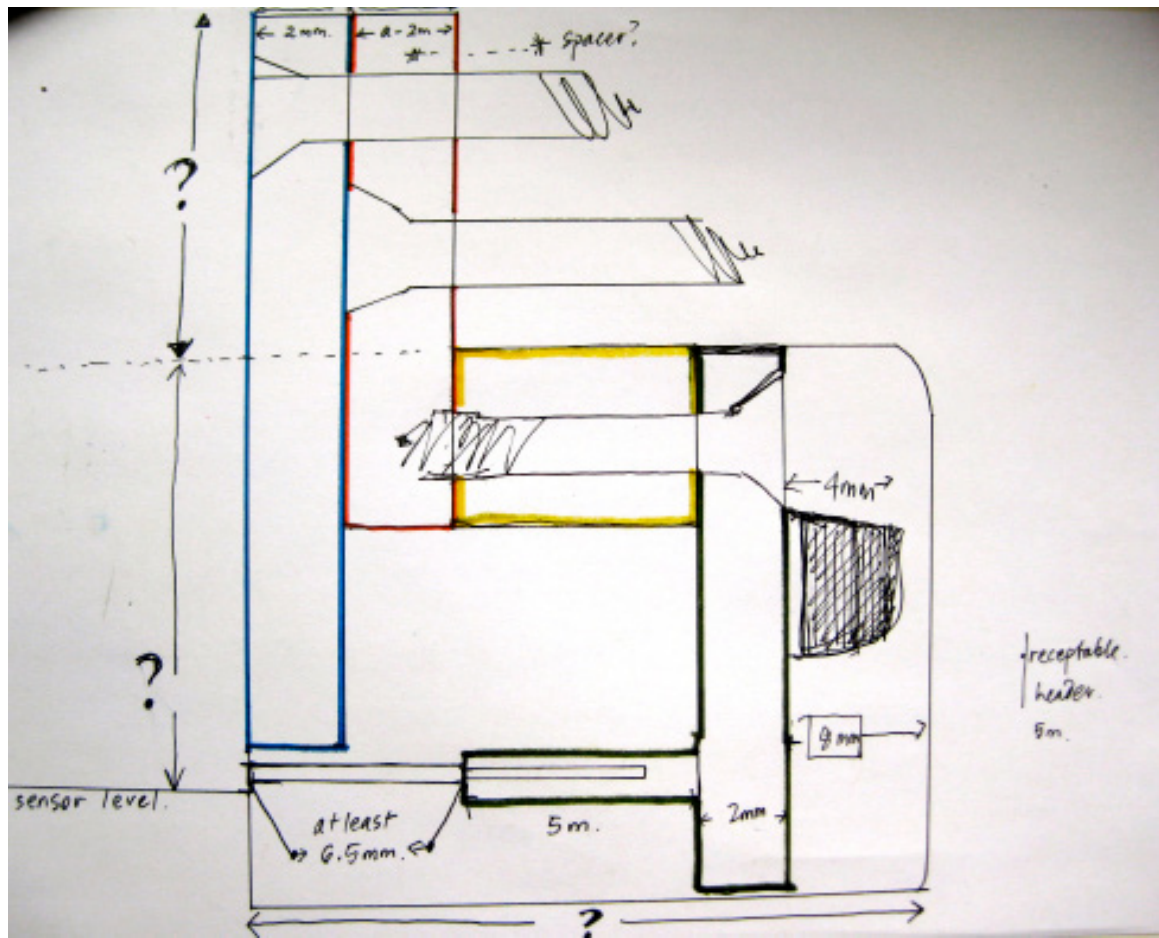

Figure 115
 Seaboard 3 chassis part connection design
 February - September 2010

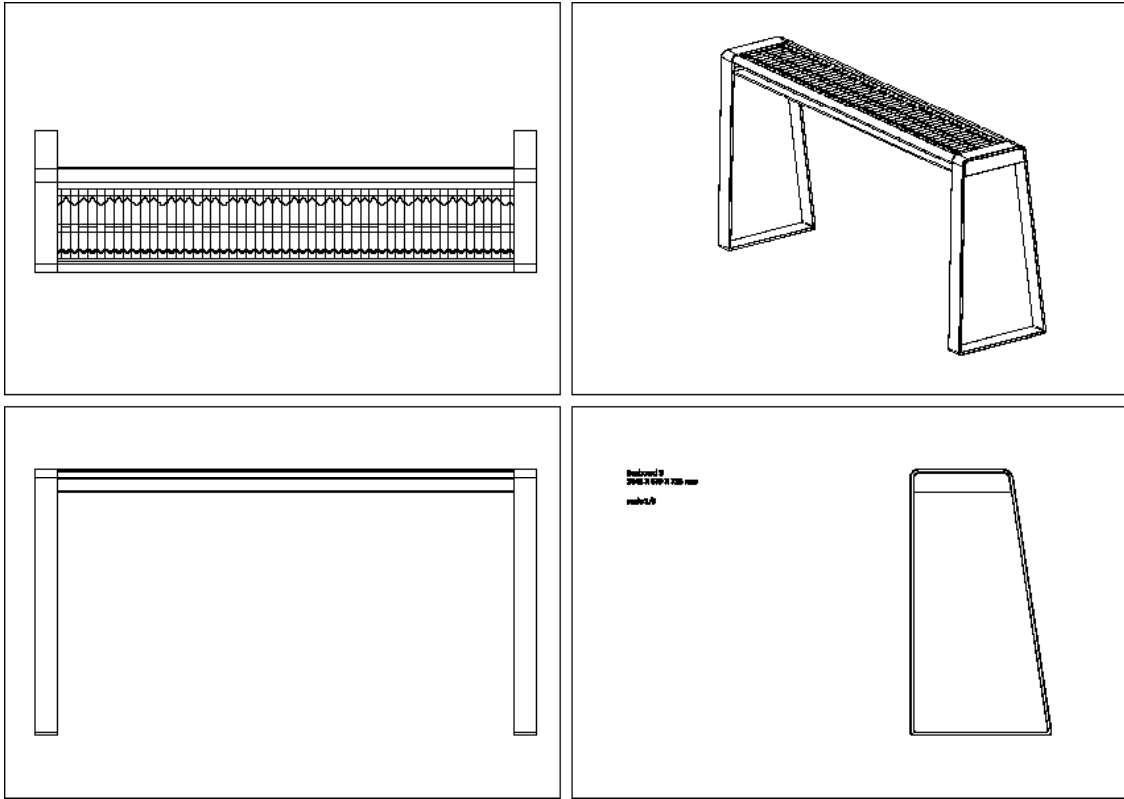

Figure 116

Seaboard 3 2D design drawing (multi-view)

February - September 2010



Figure 117

Seaboard 3 and stand rendering (front perspective)

February - September 2010



Figure 118

Seaboard 3 and stand rendering (right perspective)

February - September 2010



Figure 119
Seaboard 3 and stand rendering (right perspective)
February - September 2010



Figure 120

Seaboard 3 and stand rendering (top view)

February - September 2010

The Seaboard 3 was the first fully-working Seaboard prototype. This 88-key model contains all three major components of the Seaboard: the elastomer surface, the sensors, and the enclosed chassis. This is the first model which contains an enclosure chassis. The design intention was to create a full size model and then redesign another smaller model at a later date which is more easily transported for the artists on the road. The key tones, white main keys and black sharps and flats, as well as the key positioning, vertical to the chassis bottom edge, intentionally resemble the design language of a piano.



Figure 121
Seaboard 3 keys (top view detail)
February - September 2010



Figure 122

Seaboard 3 mold (top view)

February - September 2010

The mold is made of coated AES. The separator allowed modular casting.

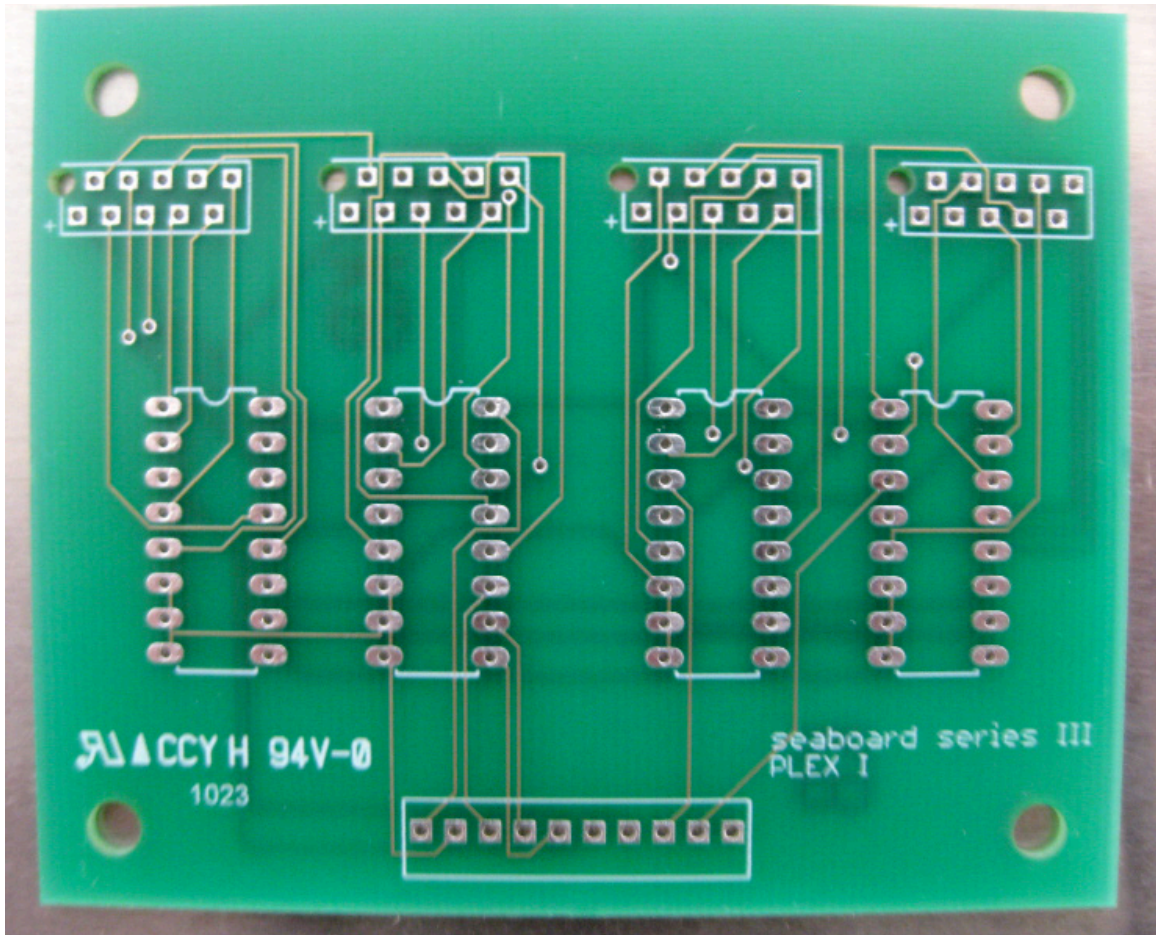

Figure 123
Seabaord 3 PCB (front view)
February - September 2010

A Seabaord 3 multiplexing board.

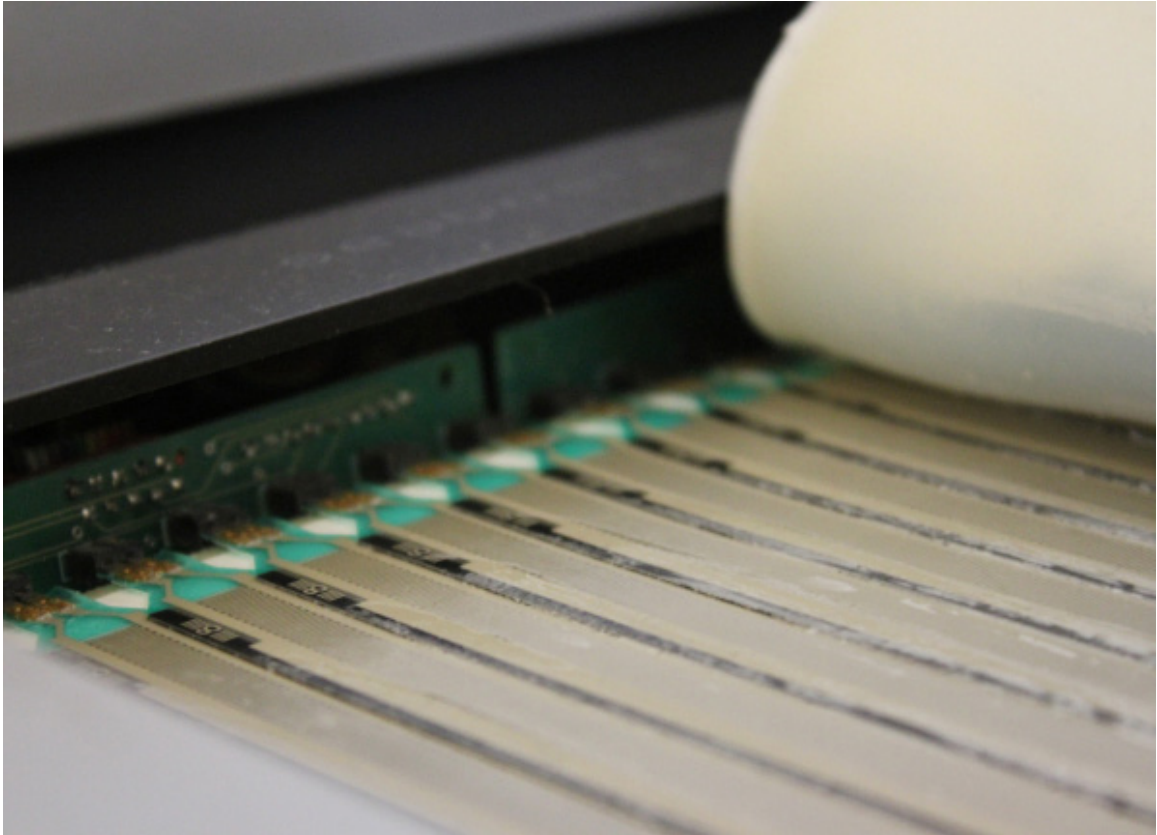

Figure 124

Seaboard 3 sensor to PCB connection (left perspective detail)

February - September 2010

The most difficult part of assembly was plugging the sensors in to these sensor boards.



Figure 125

Seaboard 3 display set-up at the RCA Masters Design Show (right perspective)

February - September 2010

Cables had to be set in place before it could be closed.



Figure 126

Seaboard 3 partial cast (right perspective detail)

February - September 2010

An all white cast for the Seaboard 3.



Figure 127
Seaboard 3 (right perspective)
February - September 2010

Notice the adjusted simpler shaped palm pad.

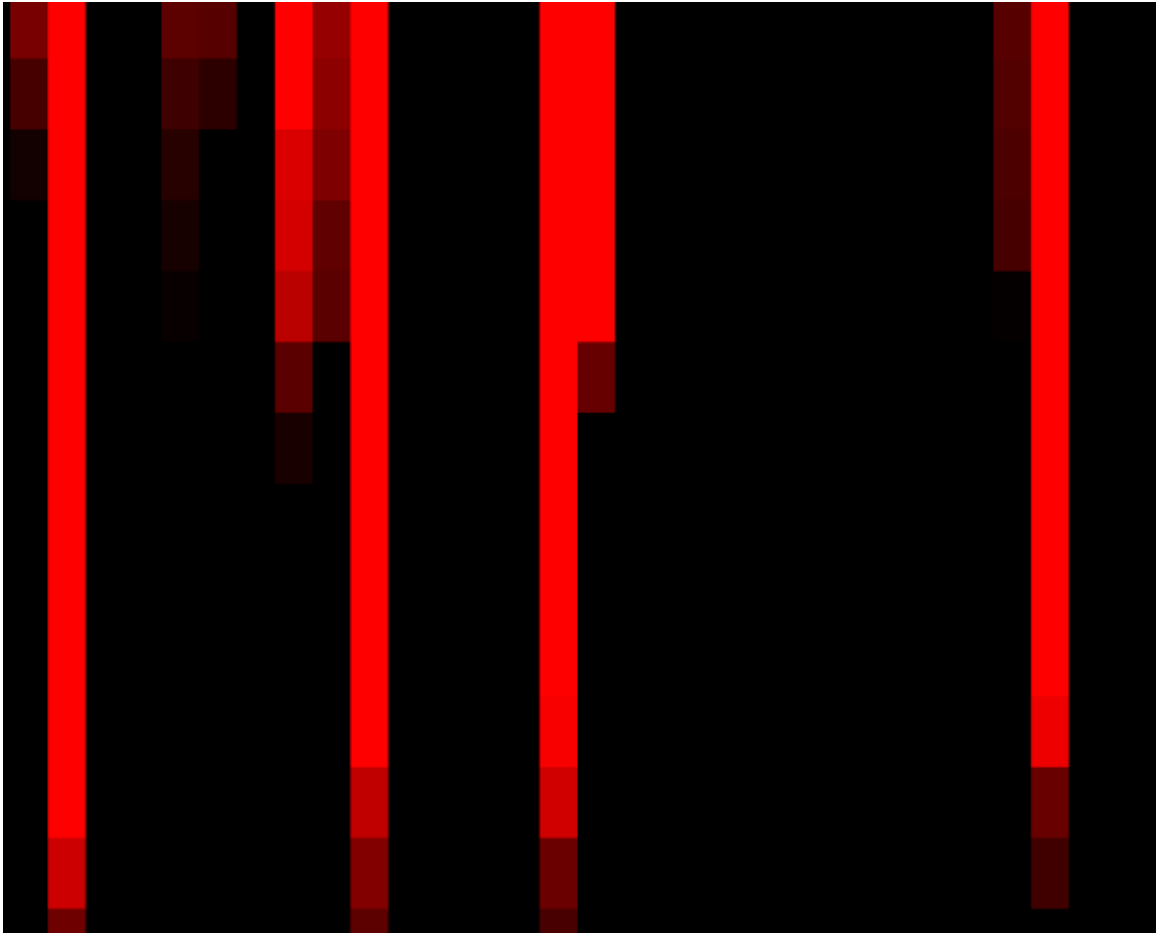

Figure 128

Seaboard 3 GUI (screen view)

February - September 2010

The Seaboard 3 started with a simple GUI showing a pressure map.

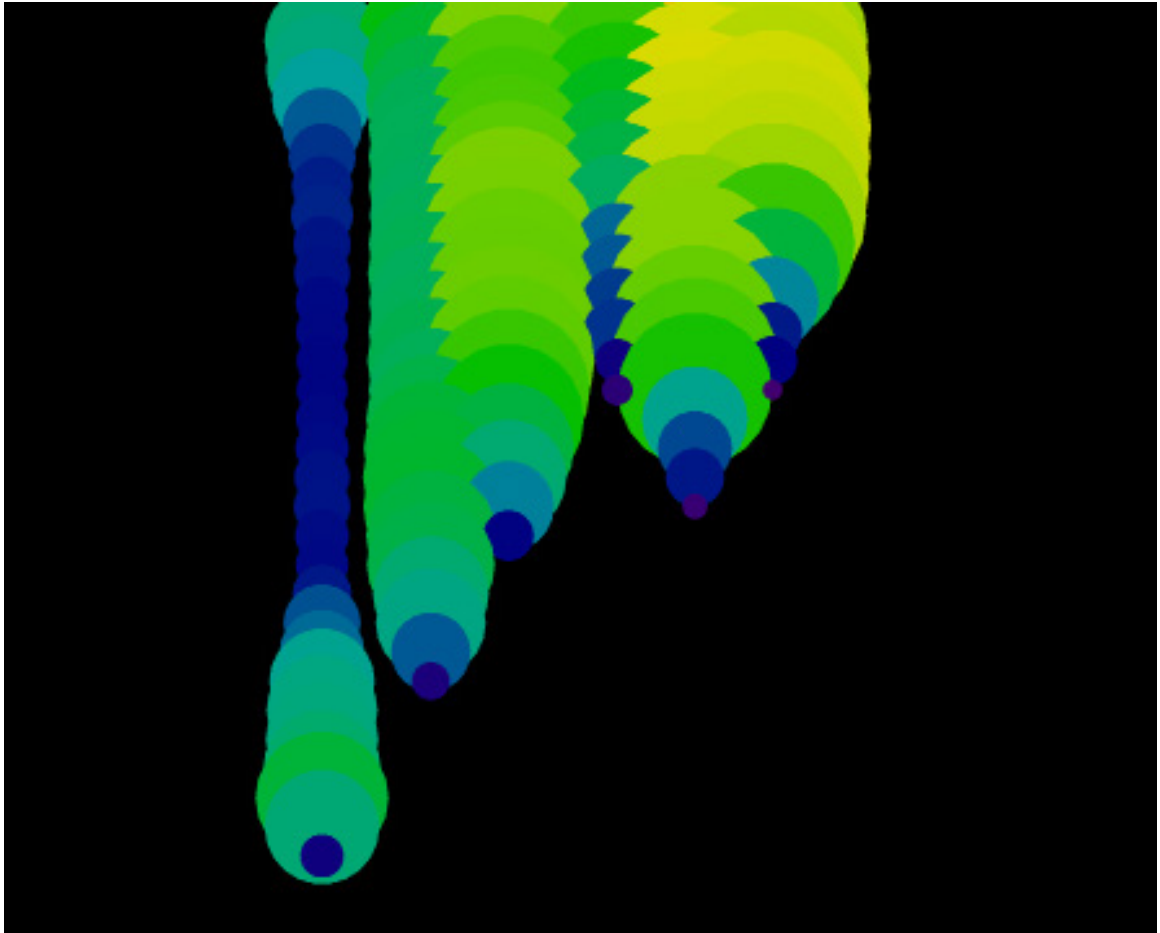

Figure 129
Seaboard 3 GUI (screen view)
February - September 2010

Notes were then visualised once they had been tracked.

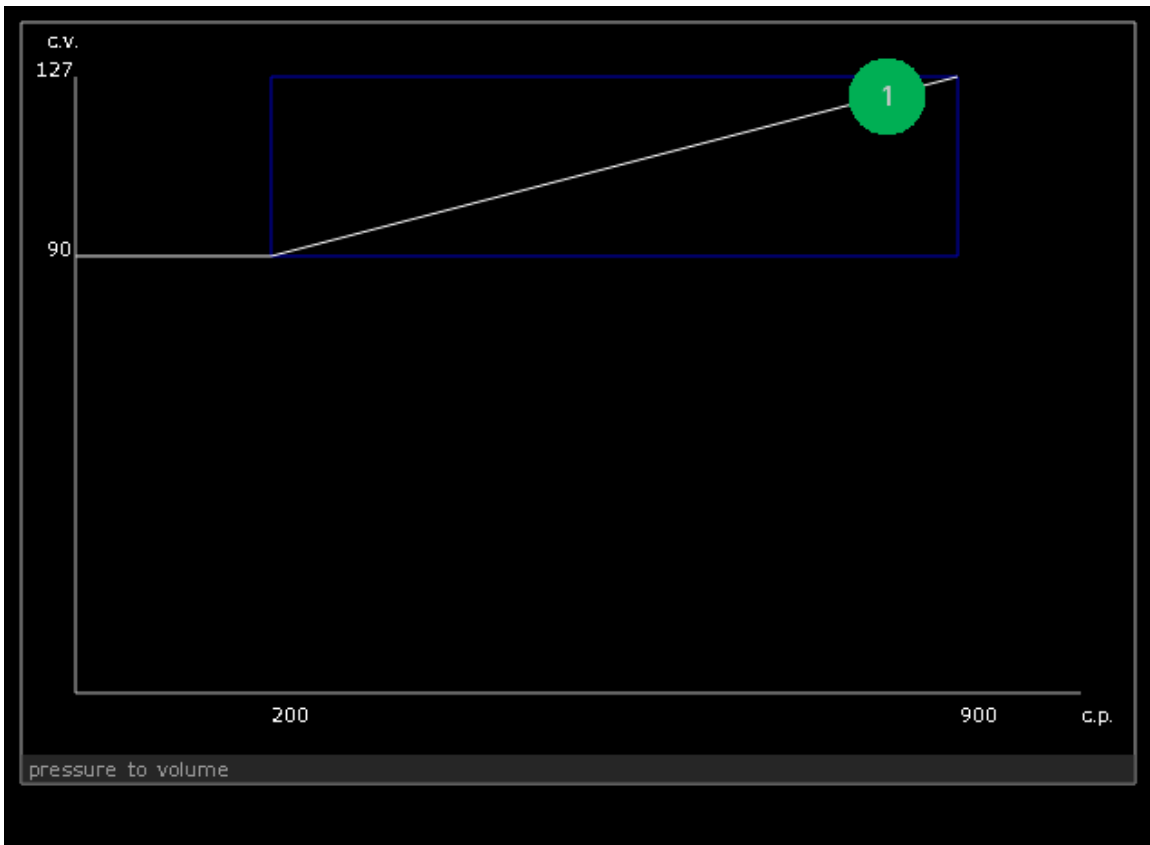

Figure 130

Seaboard 3 GUI (screen view)

February - September 2010

This shows a basic translation graph mapping pressure to volume.

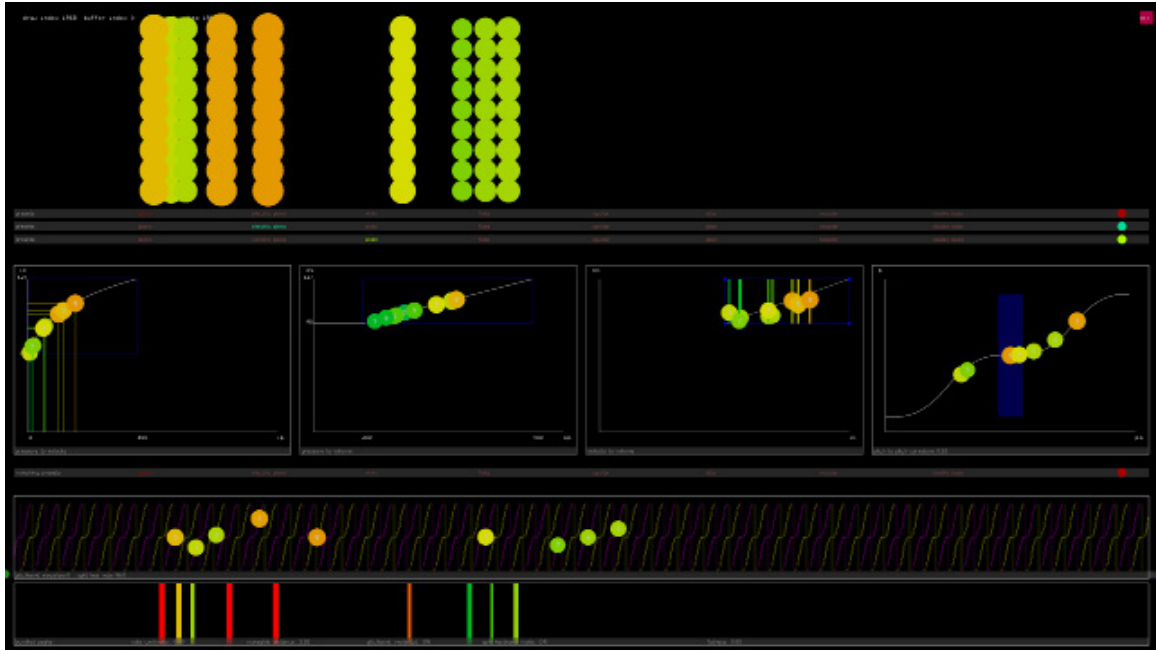

Figure 131
Seaboard 3 GUI (screen view)
February - September 2010

This image shows the full Seaboard 3 GUI, which mapped several different variables in real-time polyphonically.

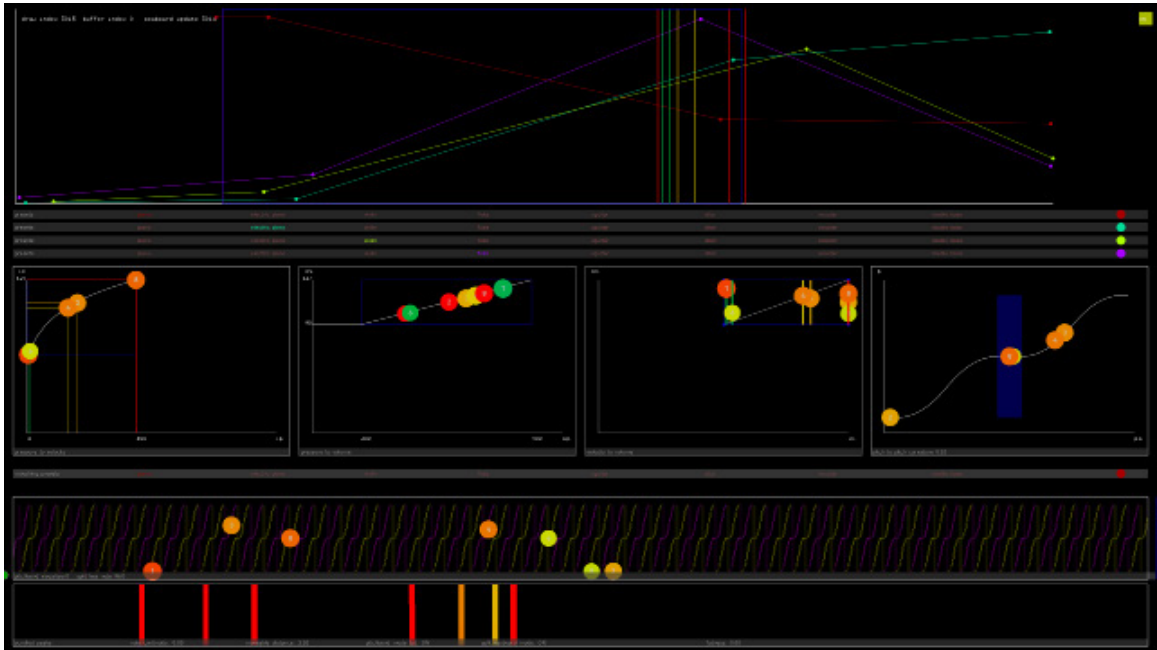

Figure 132

Seaboard 3 GUI (screen view)

February - September 2010

It also enabled one to morph through a relative mix of different sound depending on pressure and pedal location.



Figure 133
Canon digital camera (detail)
circa 2012

This illustrates the 'double pillow.'



Figure 134
iPod (detail)
Circa 2010

The surface is nearly flat with just a subtle finessed edge.



Figure 135
Mac Book Pro (detail)
2010

A detail of the front profile of a Mac Book Pro. This is another double pillow shape. In some cases a double pillow functions to make only the flat edge read as the side edge, meaning that the perception of thinness is emphasized. Notice also that the break line on the bottom side of the case will be hidden from almost all viewpoints that take place during normal use.

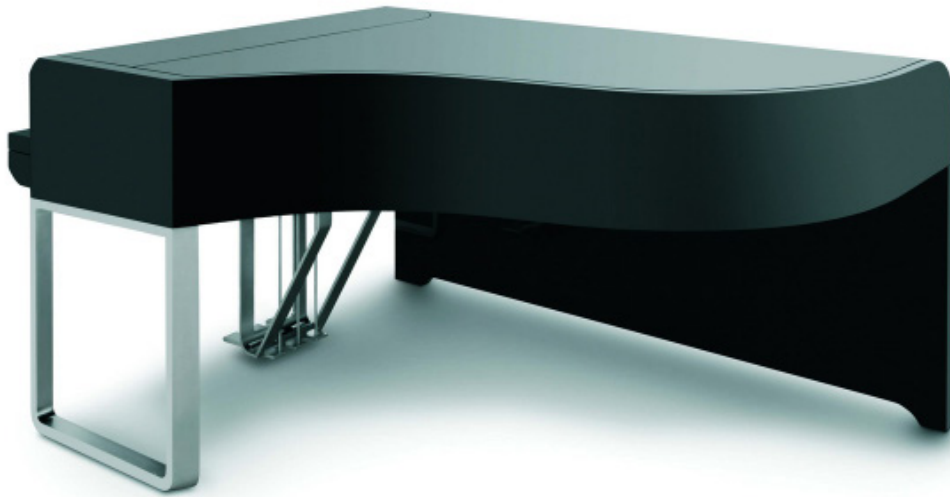

Figure 136

Audi Piano Design (back perspective)

2006

An attempt to modernise the formal design qualities of the piano with stronger mixed lines and materials.



Figure 137
Audio Piano Design (front detail)
2006



Figure 138

B&W Speaker 800 Series Diamond (detail)

2012

The B&W speakers shown here also demonstrate mixed materials, and use a contrast between a traditional material, in this case wood, and very modern organic form factors.



Figure 139
Modern digital piano (detail)
circa 2005

A USB stick in the front of a wood encased digital piano, reveals how difficult it can be to get the right mix of functionality and semantic communication. The USB drive is a helpful contemporary was of uploading sounds, and the wooden case is an attractive traditional casing for a piano, but the two will never sit happily together.



Figure 140
Nokia Lumia Back (back view)
circa 2011



Figure 141
Porsche Piano (right perspective)
circa 2003



Figure 142
Porsche Piano Pedal (detail)
circa 2003

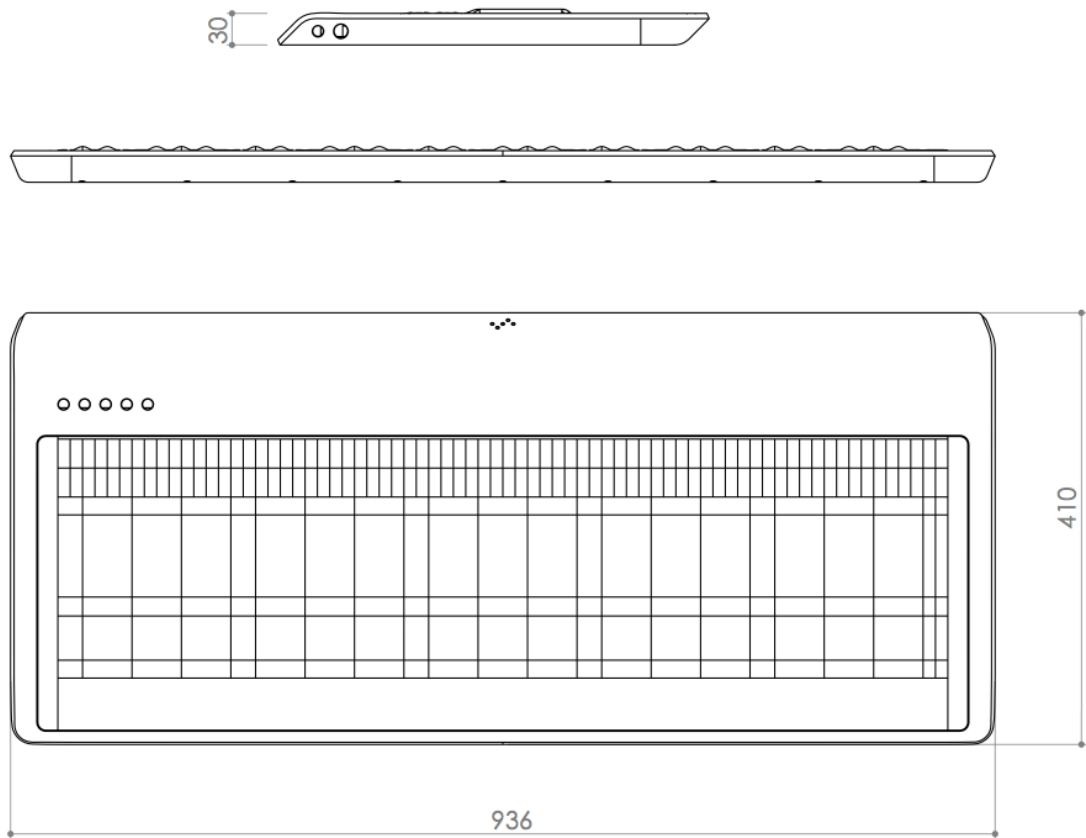

Figure 143
Seaboard LUTE A 2D drawing
April - September 2011

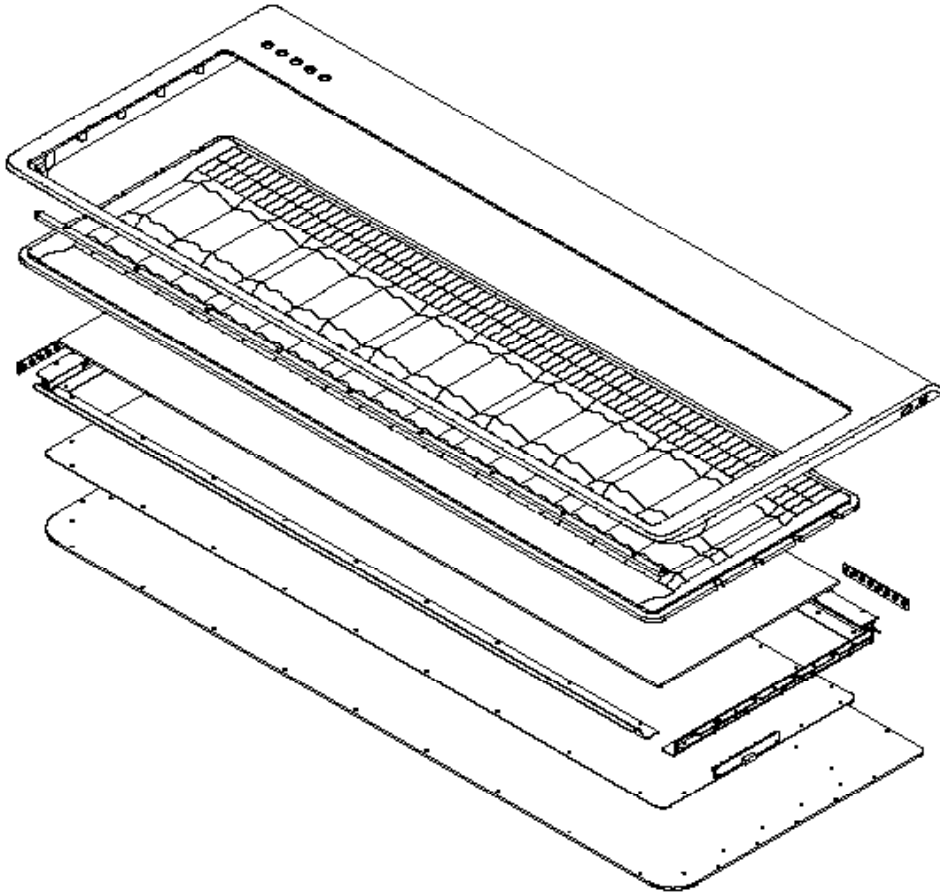

Figure 144
Seaboard LUTE A exploded isometric drawing
April - September 2011

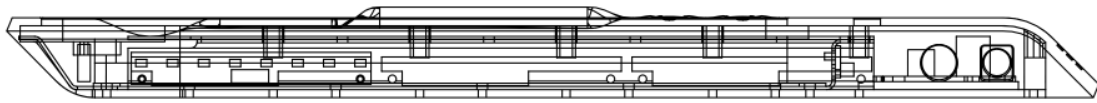

Figure 145
Seaboard LUTE A internal structure
April - September 2011



Figure 146

Seaboard LUTE A rendering

April - September 2011



Figure 147
Seaboard LUTE A rendering
April - September 2011

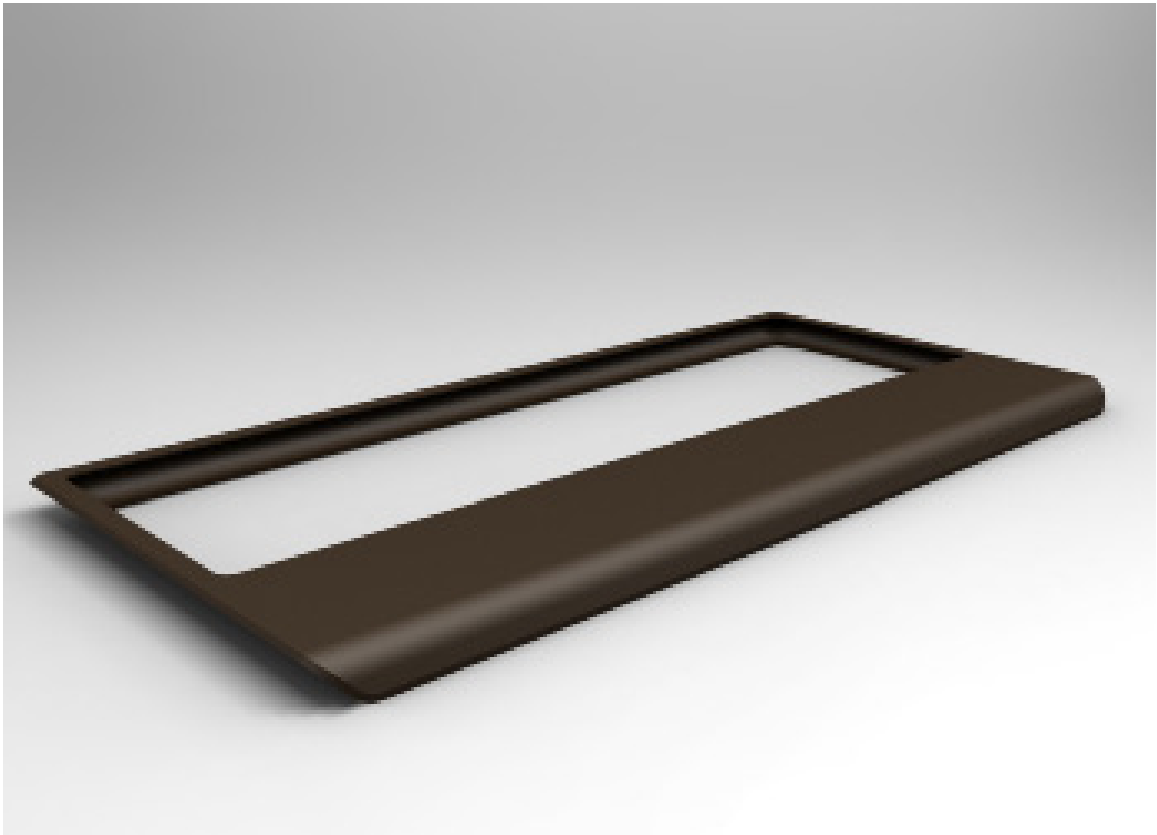

Figure 148

Seaboard LUTE A top chassis (back perspective)

April - September 2011



Figure 149

Seaboard LUTE A silicone alignment (back perspective)

April - September 2011



Figure 150

Seaboard LUTE A top chassis alignment (back perspective)

April - September 2011



Figure 151
Seaboard LUTE A (right perspective)
April - September 2011



Figure 152

Seaboard LUTE A (back perspective)

April - September 2011



Figure 153

Seaboard LUTE B Technology Development (front perspective)

August - November 2011



Figure 154

Seaboard LUTE B top chassis (top view)

August - November 2011

This prototype chassis was designed with a wider upper and thinner lower surface. It is made of aluminium 5 series, sandblasted and anodized ivory black.



Figure 155
Seaboard LUTE B top chassis (front elevation)
August - November 2011



Figure 156

Seaboard LUTE B top chassis (left perspective)

August - November 2011



Figure 157
Seaboard LUTE B top chassis (left side perspective)
August - November 2011

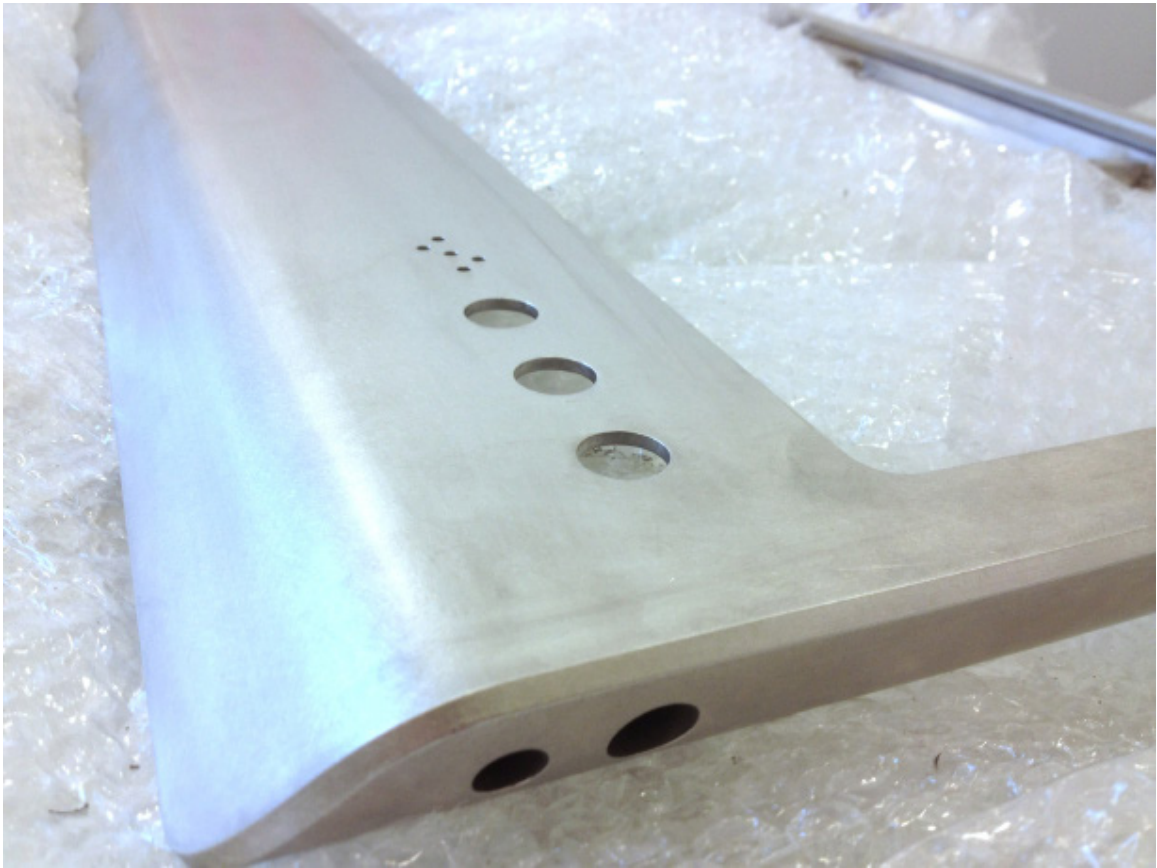

Figure 158
Seaboard LUTE C chassis (right perspective detail)
October 2011 - July 2012



Figure 159
Seaboard LUTE C assembled (left perspective)
October 2011 - July 2012



Figure 160

Seaboard LUTE C (top view)

October 2011 - July 2012

Notice the poor alignment of the silicone component.



Figure 161
Seaboard LUTE C (front elevation)
October 2011 - July 2012

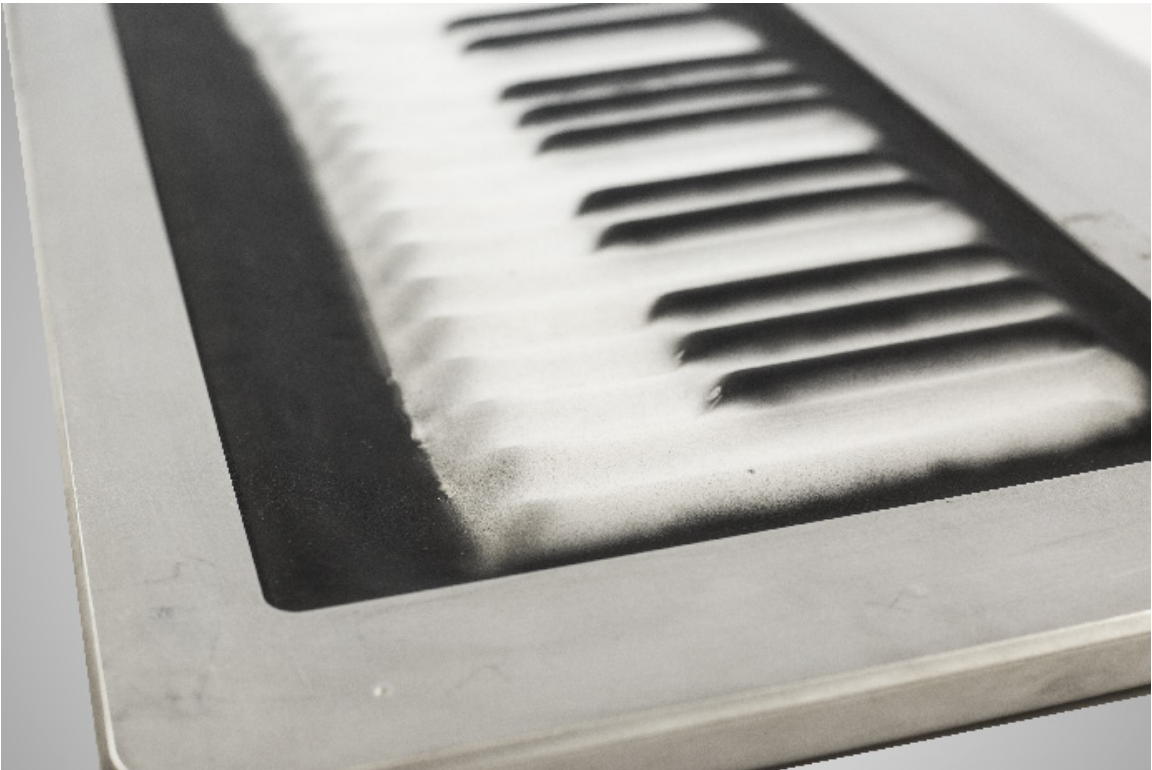

Figure 162

Seaboard LUTE C (right perspective detail)

October 2011 - July 2012

This model ribbon is pigmented black to visually distinguish it from the main white keys using an early and unsuccessful spray technique.



Figure 163

Seaboard LUTE C and generic stand (right perspective)

October 2011 - July 2012



Figure 164
LUTE C cable management
June 2012



Figure 166

Seaboard LUTE D rendering (front perspective)

June - September 2012

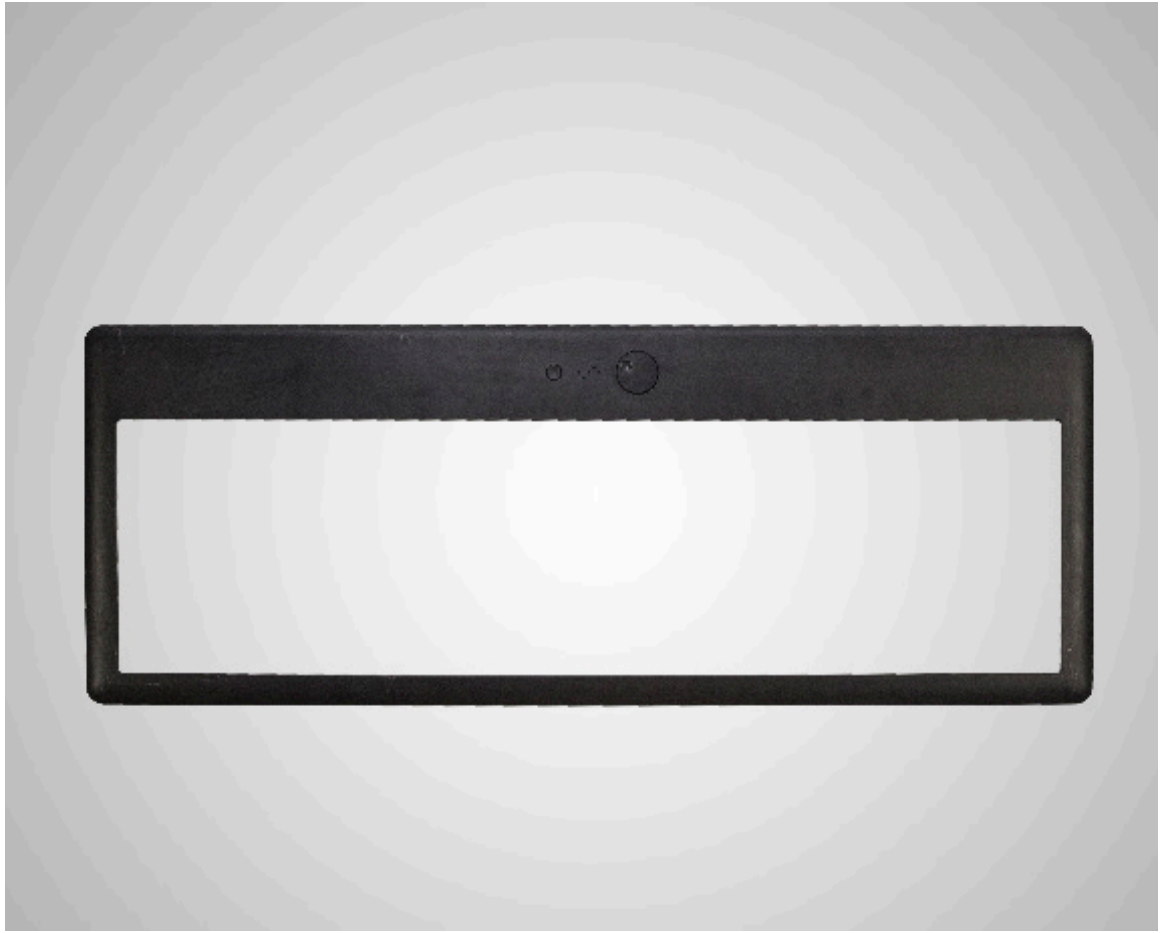

Figure 167

Seaboard LUTE D top chassis (top view)

June - September 2012



Figure 168
Seaboard LUTE D top chassis (front elevation)
June - September 2012



Figure 169
Seaboard LUTE D top chassis (right perspective)
June - September 2012



Figure 170

Seaboard LUTE D top chassis (right side perspective)

June - September 2012



Figure 171

Seaboard LUTE D top chassis (back elevation)

June - September 2012



Figure 172

Seaboard LUTE D top chassis (back elevation)

June - September 2012



Figure 173

Seaboard LUTE D and generic stand (front perspective)

June - September 2012



Figure 174
Seaboard LUTE D Sound Dial (left perspective detail)
June - September 2012



Figure 175

Seaboard LUTE D and generic stand (right perspective detail)

June - September 2012



Figure 176
Seaboard LUTE D (left side detail)
June - September 2012



Figure 177

Seaboard LUTE D and generic stand (right perspective)

June - September 2012

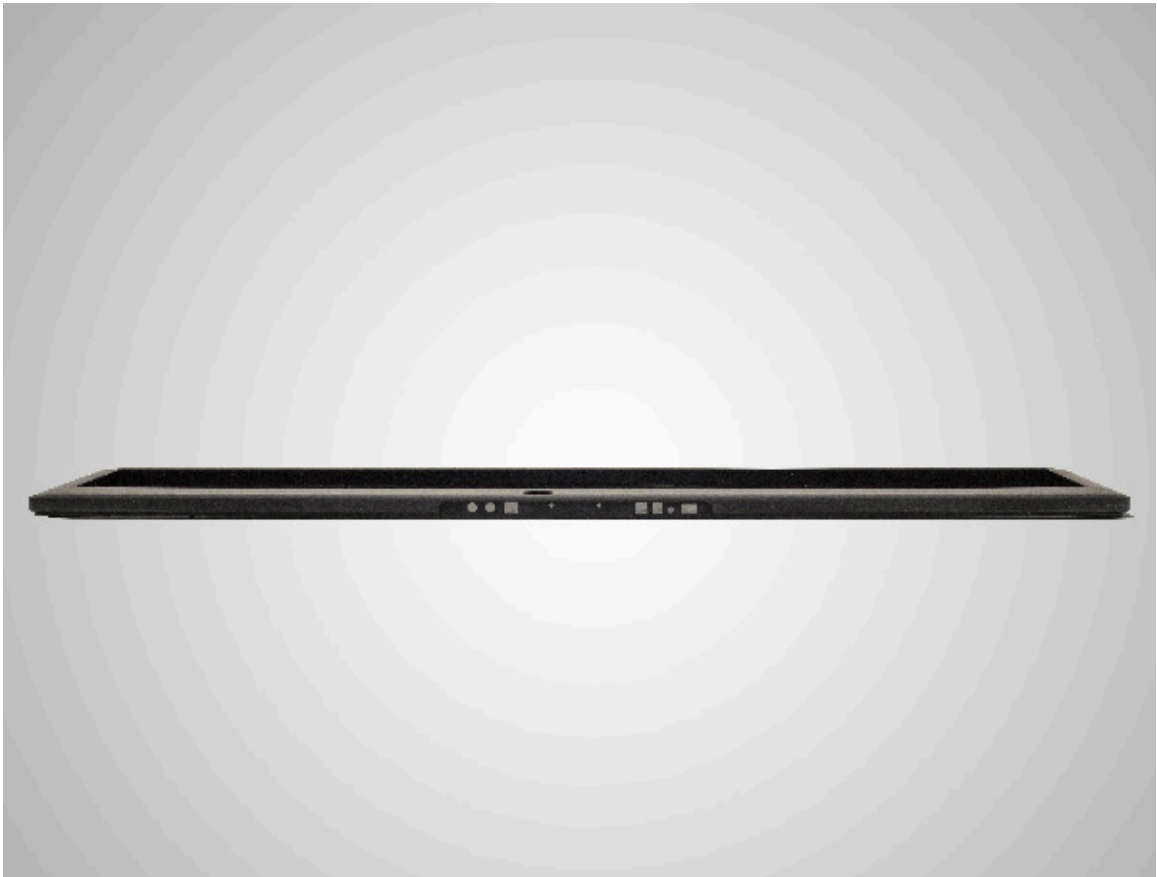

Figure 178

Seaboard LUTE D chassis (back elevation)

July - October 2012

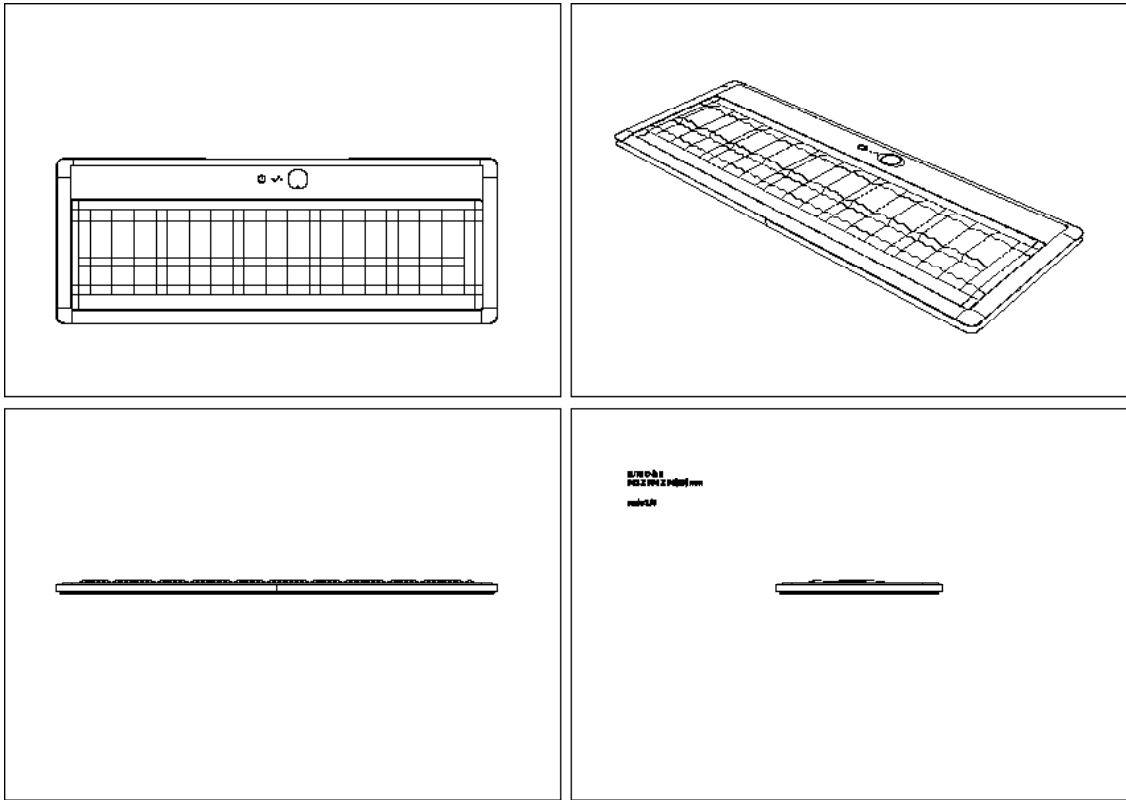

Figure 179
Seaboard LUTE D# 2D drawing (multi-view)
July - October 2012



Figure 180

Seaboard LUTE D# chassis (front elevation)

July - October 2012



Figure 181
Seaboard LUTE D# chassis (left side perspective)
July - October 2012



Figure 182

Seaboard LUTE D# chassis (right perspective)

July - October 2012

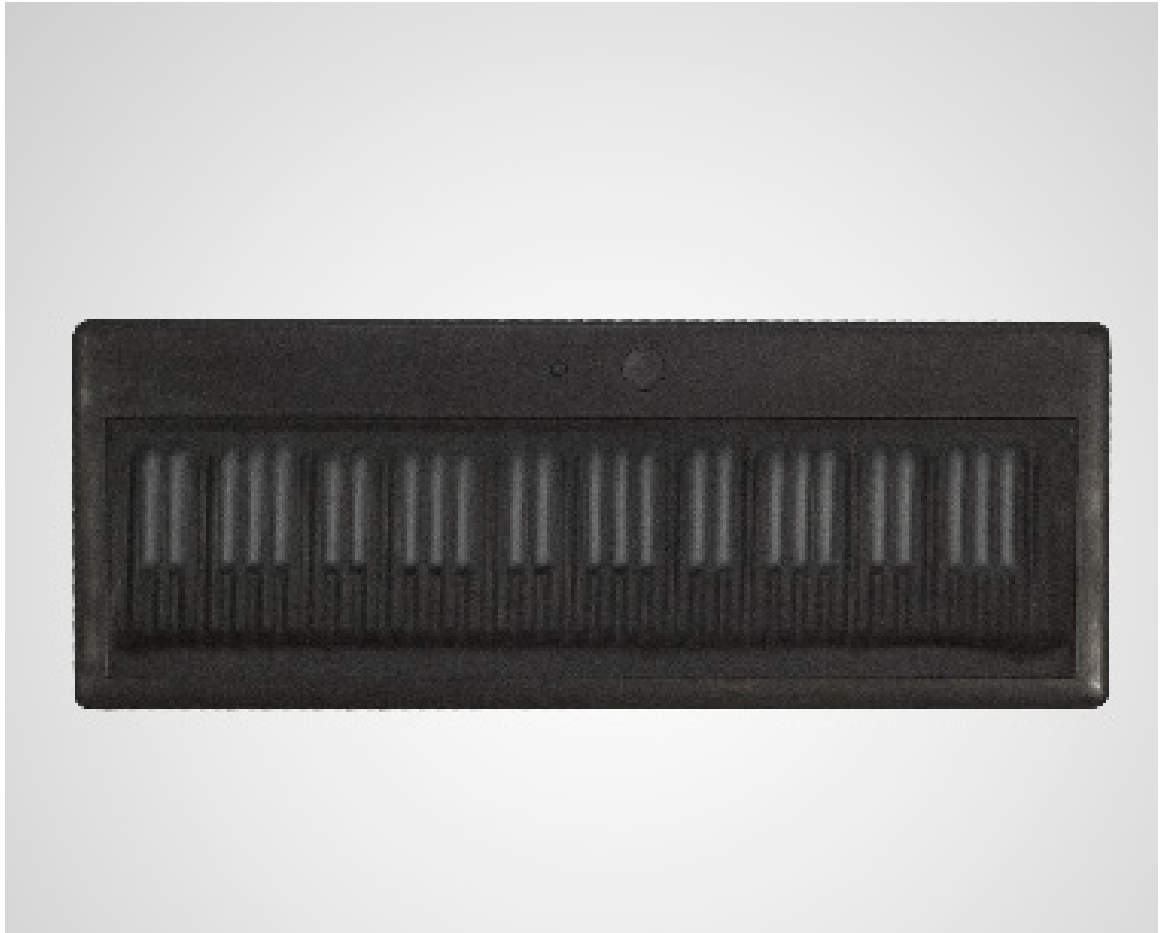

Figure 183
Seaboard LUTE D# (top view)
July - October 2012



Figure 184

Seaboard LUTE D# (front elevation)

July - October 2012

The major design issues with the LUTE D and D# models are that the black panel is too thin to support the load of the internal parts. Three structural weaknesses prompted the question: how should the Seaboard hardware be structured so that it is strong enough of support its component parts but appears as light to present a sleek and minimalist aesthetic? This model is composed of five main components: a silicone body, a back panel, a top panel, PCBs, and functional ports.



Figure 185
Seaboard LUTE D# (right perspective)
July - October 2012



Figure 186
LUTE E chassis (internal view)
August 2012

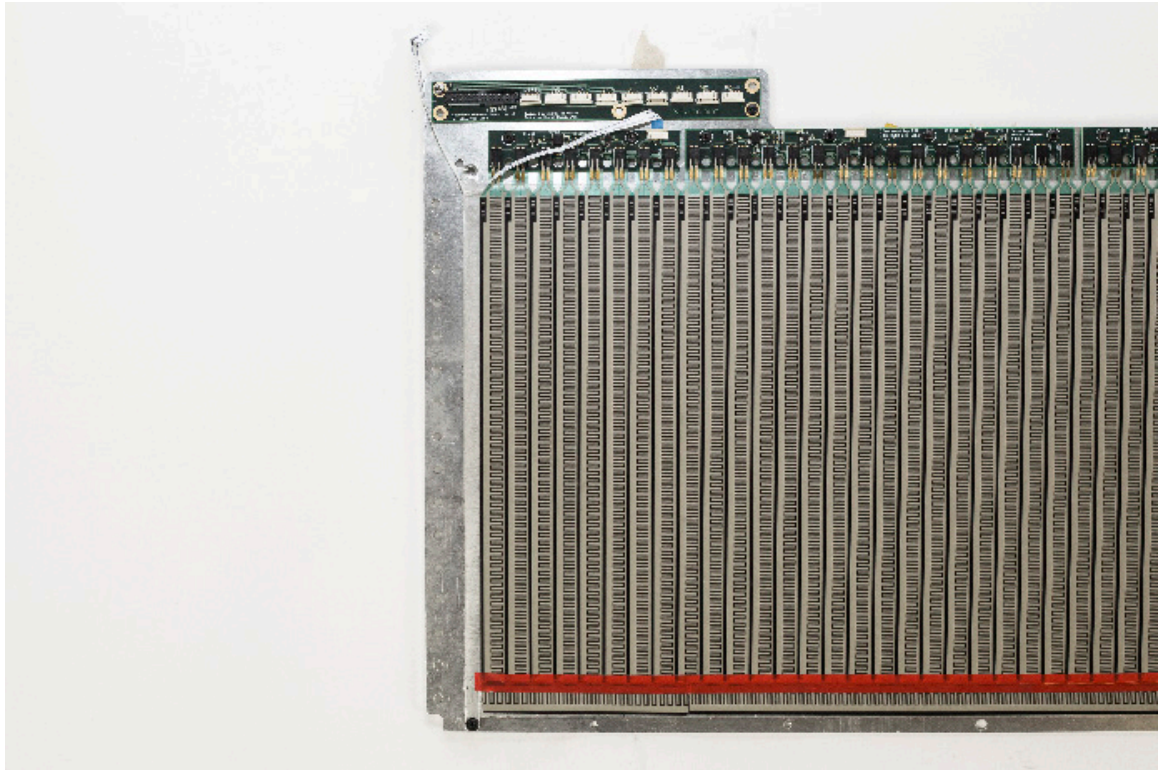

Figure 187
LUTE E sensor array (detail)
August 2012



Figure 188
Seaboard LUTE E (right perspective detail)
August - November 2012



Figure 189
Seaboard LUTE E (right perspective)
August - November 2012



Figure 190
Seaboard LUTE E (back perspective)
August - November 2012

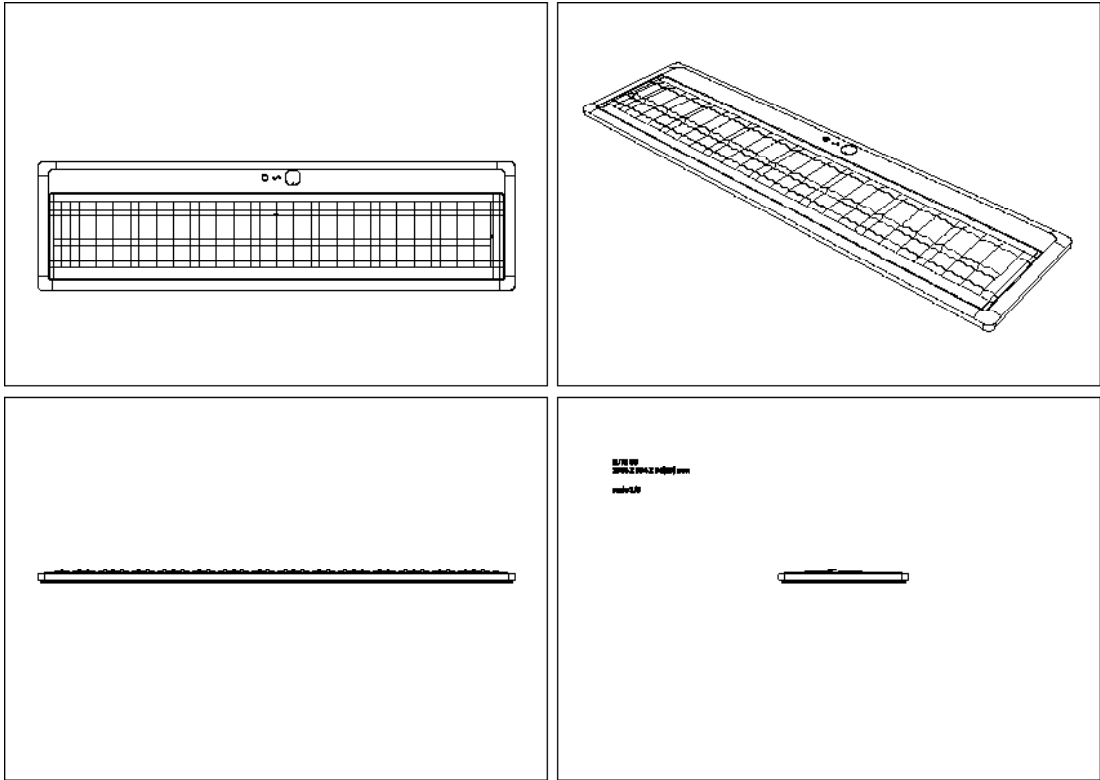

Figure 191
Seaboard LUTE E# (multi-view)
August - November 2012

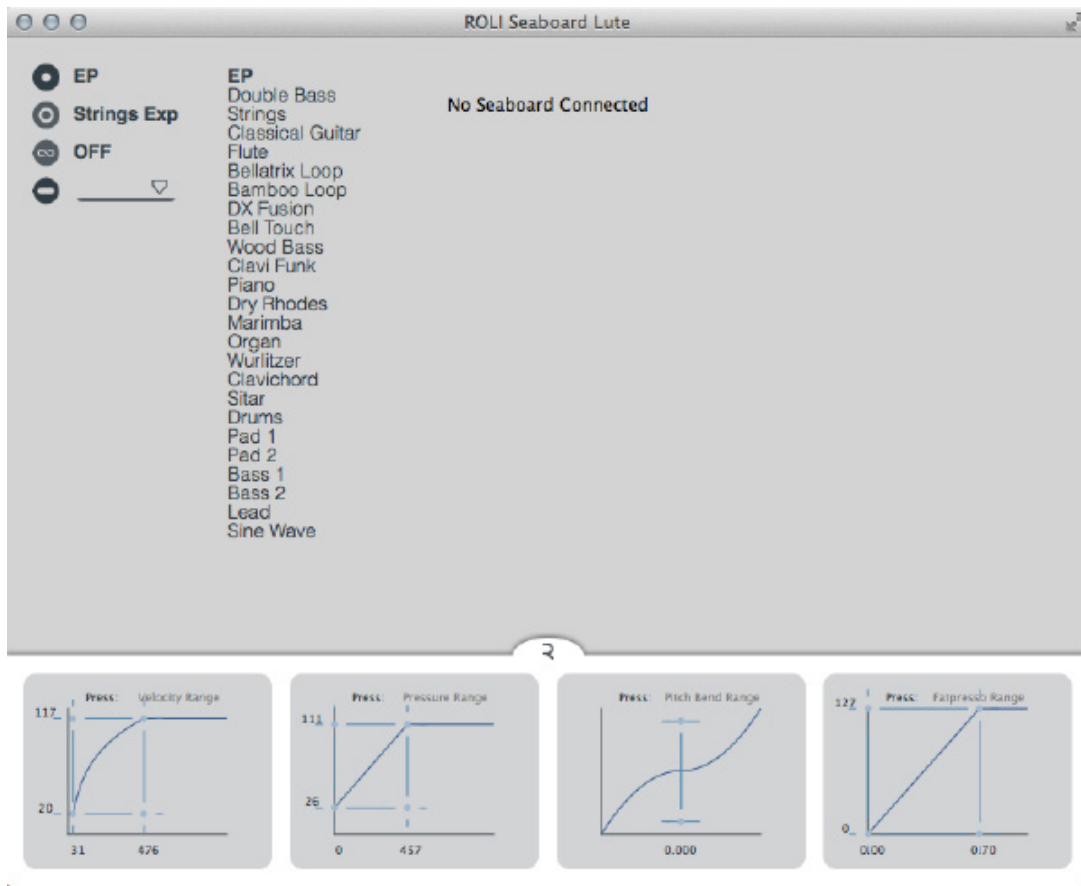

Figure 192
 Seaboard LUTE GUI (screenshot)
 October 2012

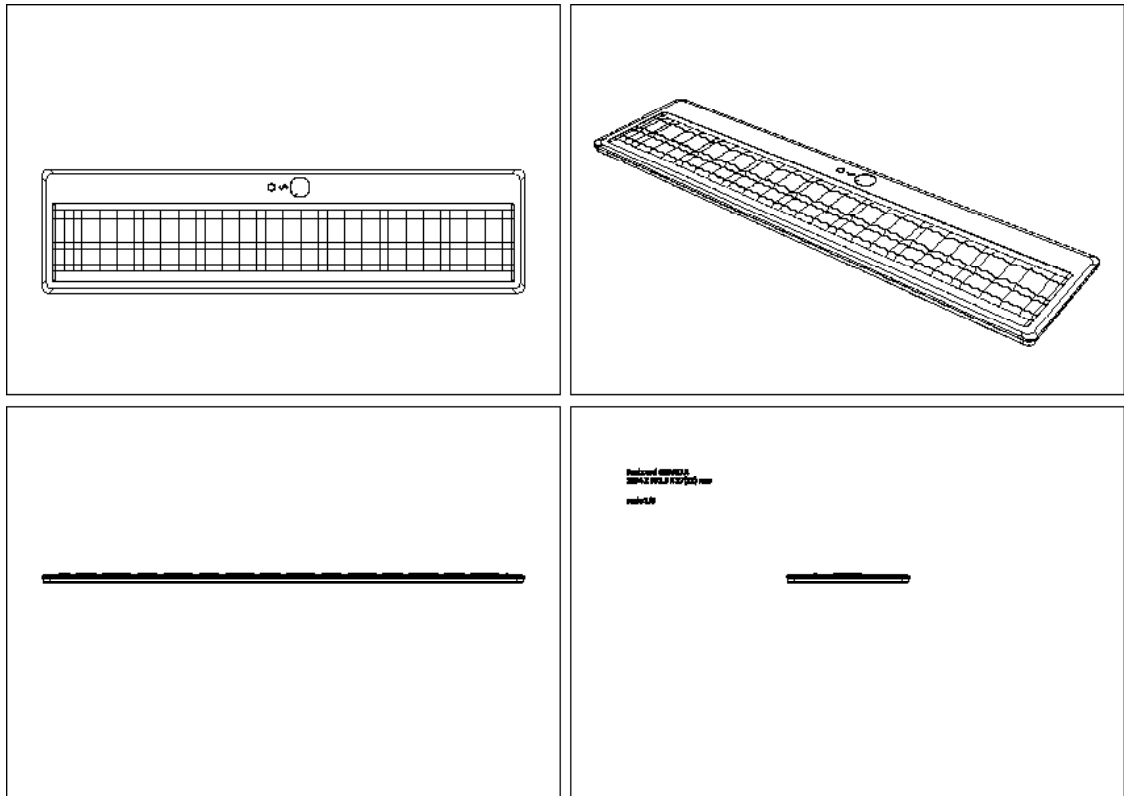

Figure 193
Seaboard GRAND A 2D drawing (multi-view)
October 2012 - January 2013



Figure 194

Seaboard GRAND A chassis (top view)

October 2012 - January 2013



Figure 195
Seaboard GRAND A chassis and sensors (top view)
October 2012 - January 2013



Figure 196

Seaboard GRAND A chassis and sensors (front elevation)

October 2012 - January 2013

The thickness was reduced from the LUTE series to the GRAND A and B by 4mm.

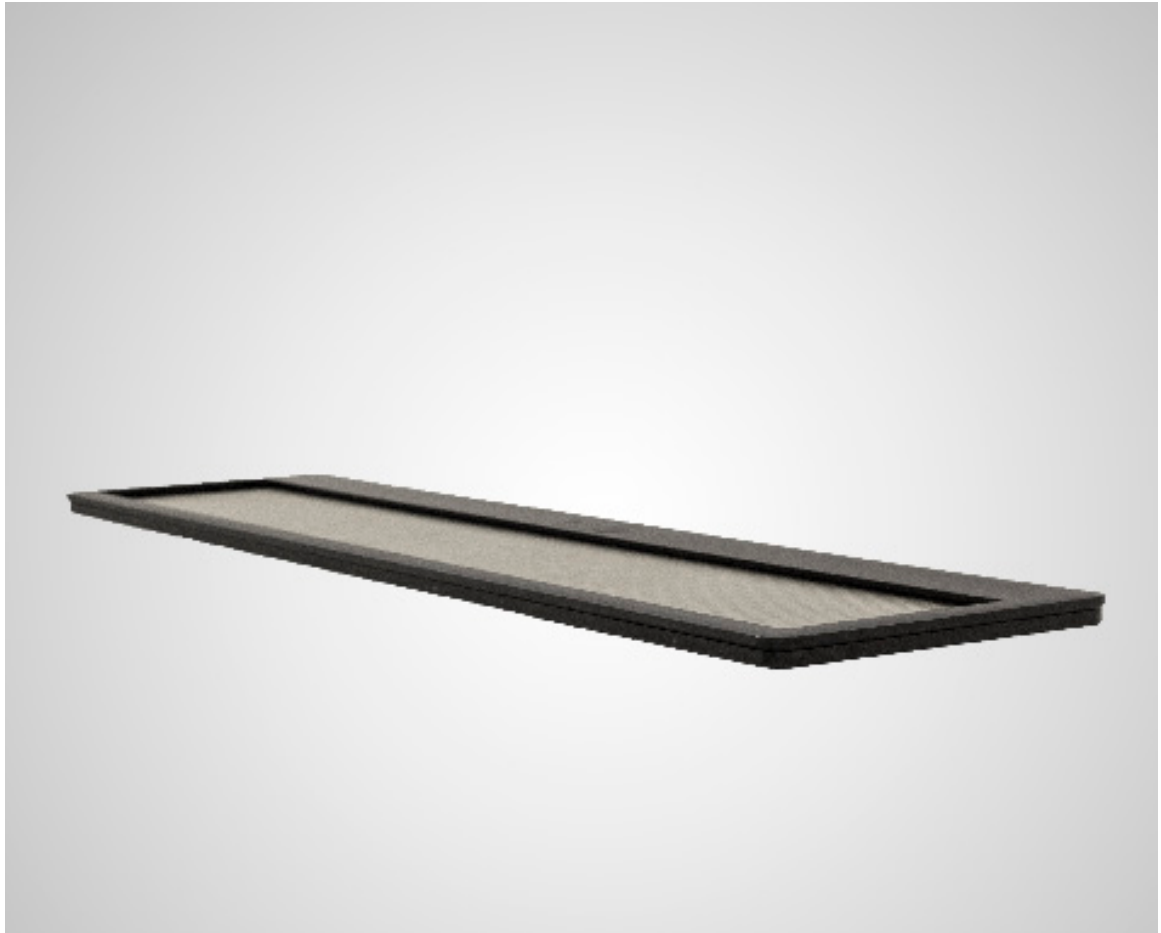

Figure 197

Seaboard GRAND A chassis and sensors (right perspective)

October 2012 - January 2013



Figure 198

Seaboard GRAND A chassis and sensors (right perspective detail)

October 2012 - January 2013

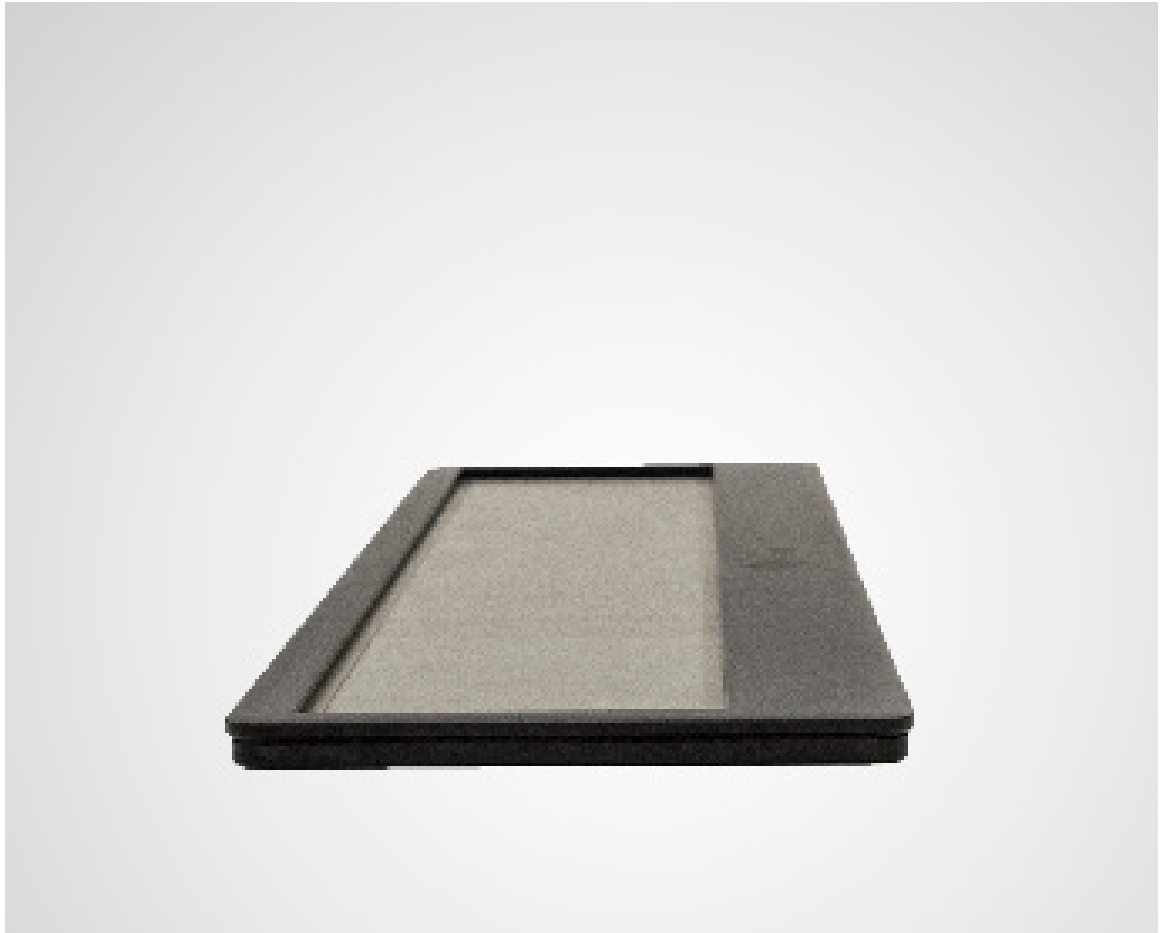

Figure 199

Seaboard GRAND A chassis and sensors (right side perspective)

October 2012 - January 2013

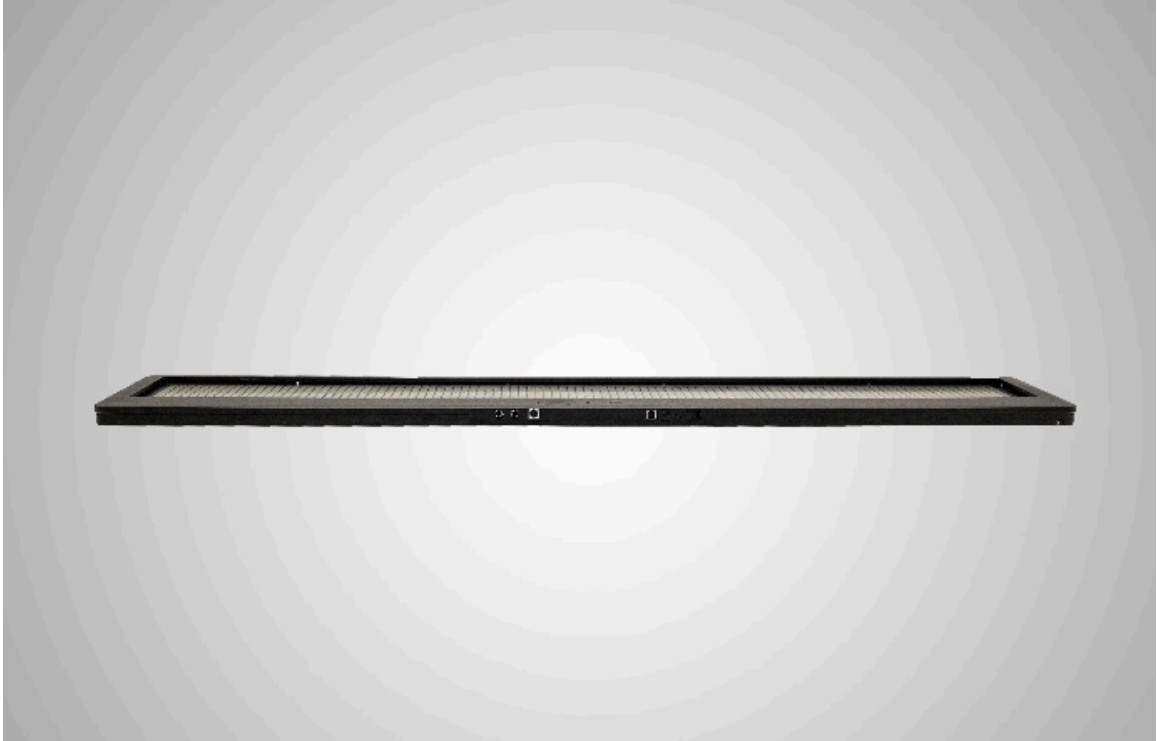

Figure 200
Seaboard GRAND A chassis and sensors (back elevation)
October 2012 - January 2013



Figure 201
Seaboard GRAND A (top view)
October 2012 - January 2013



Figure 202

Seaboard GRAND A (front perspective)

October 2012 - January 2013



Figure 203
Seaboard GRAND A (right perspective)
October 2012 - January 2013

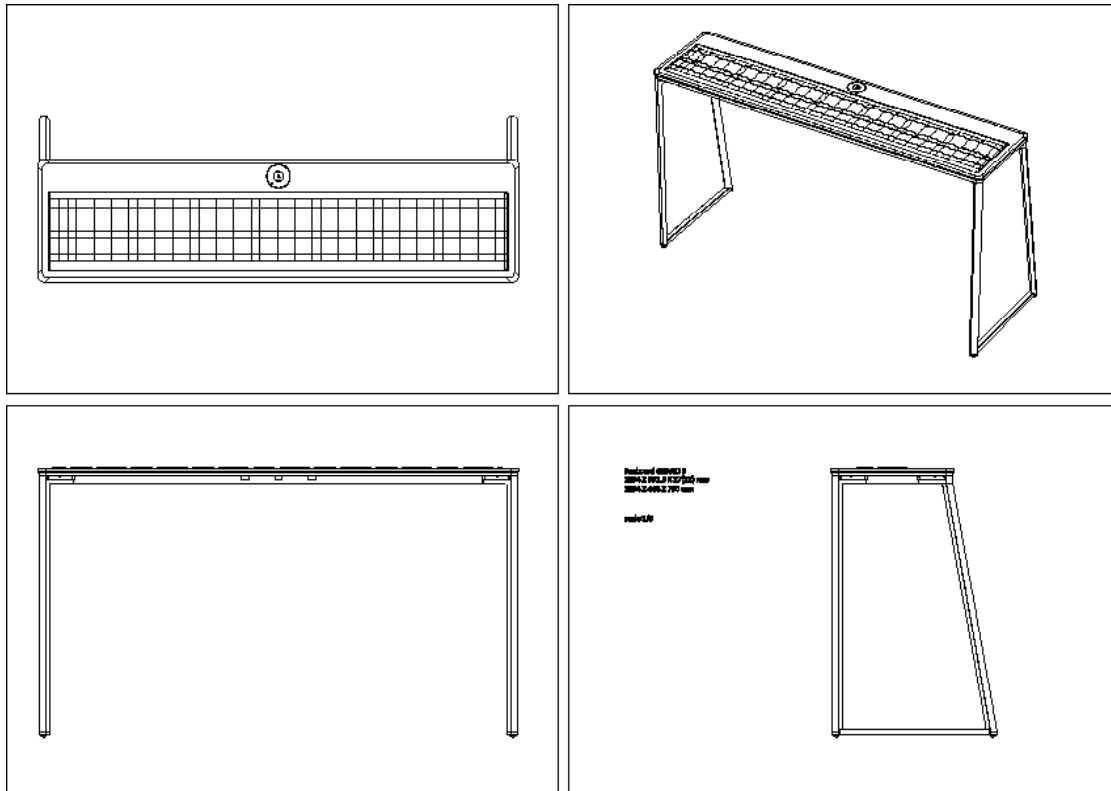

Figure 204
Seaboard GRAND B 2D drawing (multi-view)
November 2012 - April 2013

The Seaboard GRAND B is the second prototype of the Seaboard GRAND. This model marks the beginning of the Seaboard engineering and component part optimization. Until this point, the Seaboard was produced purely through design processes which allowed the product to follow the initial design vision, but which also resulted in a number of unforeseen technical issues. Nonetheless, this model is a successful example of how an initial design vision can be realized through engineering. The Seaboard visual design and design for manufacture were significantly revised for this model.



Figure 205
Seaboard GRAND B (top view)
November 2012 - April 2013



Figure 206
Seaboard GRAND B Sound Dial (detail)
November 2012 - April 2013



Figure 207

Seaboard GRAND B (front elevation)

November 2012 - April 2013



Figure 208
Seaboard GRAND B (right perspective)
November 2012 - April 2013



Figure 209
Seaboard GRAND B (left side perspective)
November 2012 - April 2013

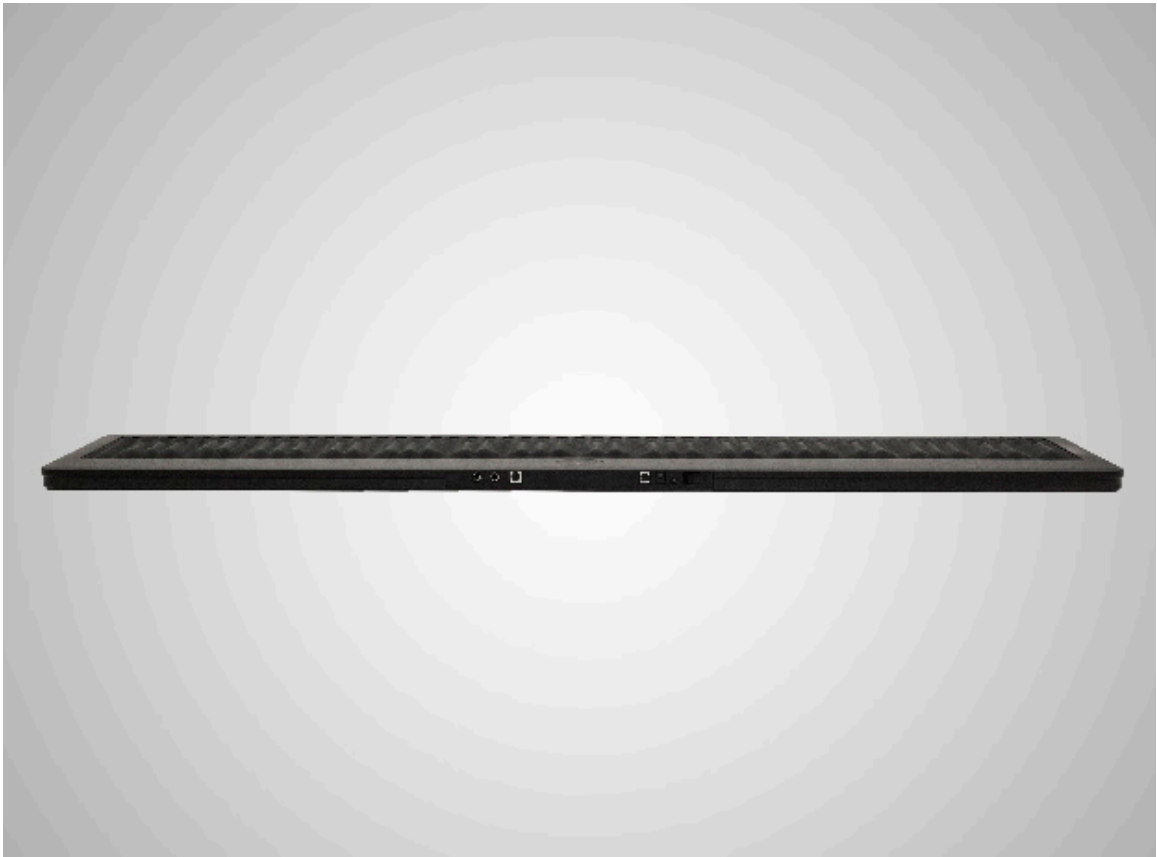

Figure 210
Seaboard GRAND B (back elevation)
November 2012 - April 2013

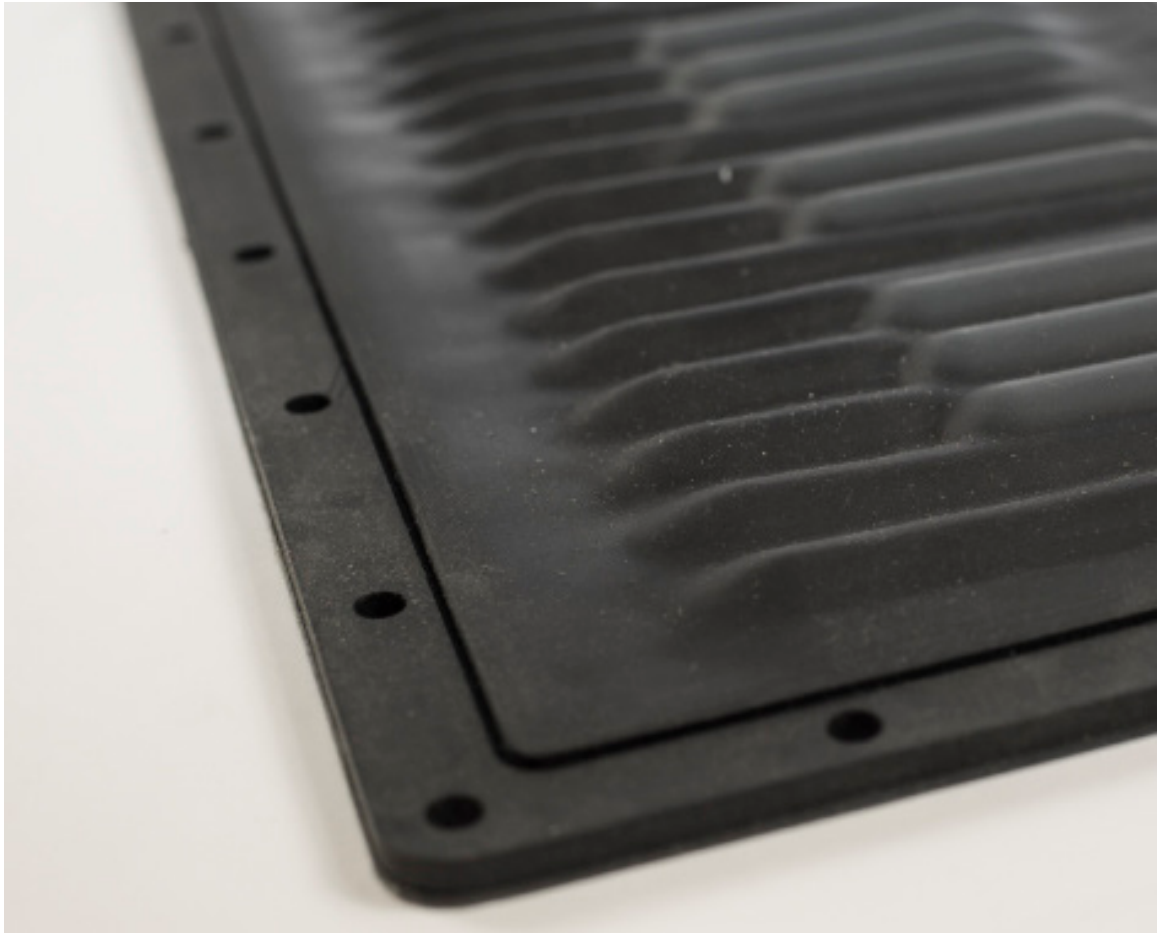

Figure 211
Seaboard GRAND B silicone (right perspective detail)
November 2012 - April 2013

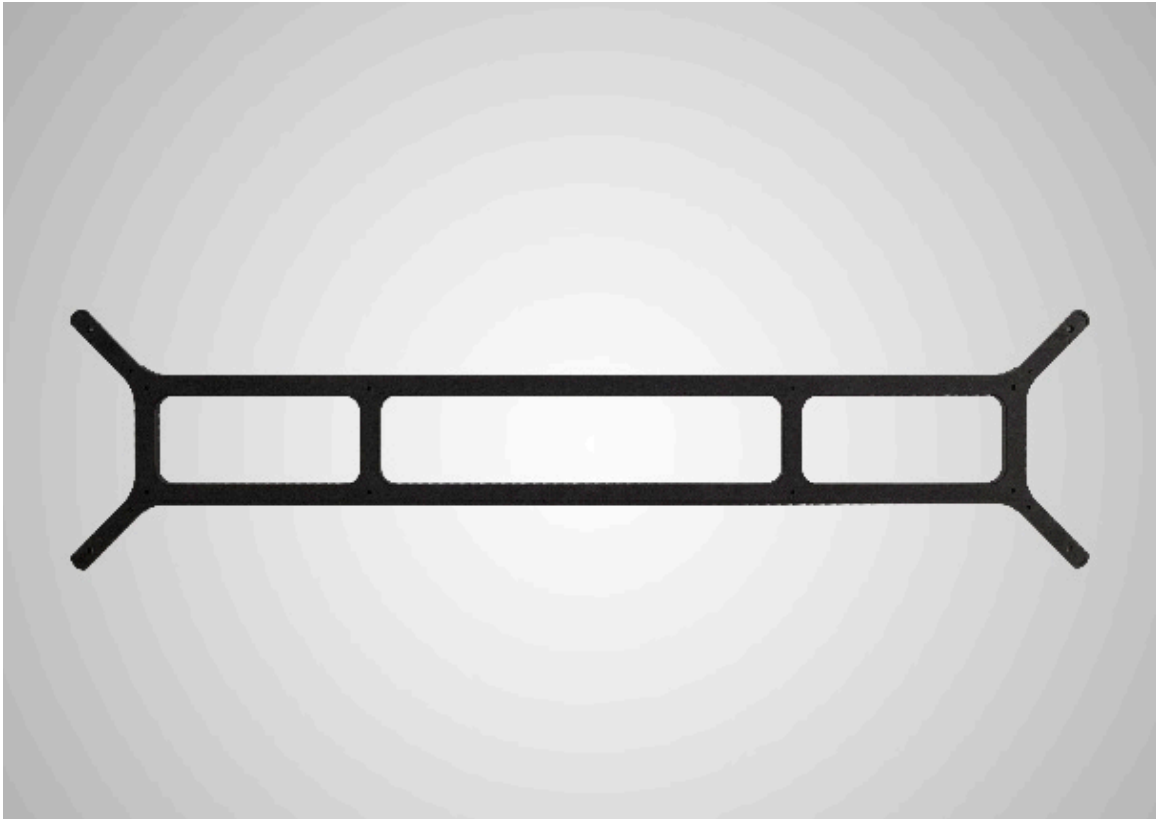

Figure 212

Seaboard GRAND B stand bed (top view)

November 2012 - April 2013

This model does not have a cable channel in the middle cross bars. The length of this body is longer than the LFE stand.



Figure 213
Seaboard GRAND B stand bed (front elevation)
November 2012 - April 2013



Figure 214
Seaboard GRAND B stand bed (right perspective)
November 2012 - April 2013



Figure 215

Seaboard GRAND B stand bed (right perspective detail)

November 2012 - April 2013



Figure 216
Seaboard GRAND B stand bed (right side perspective)
November 2012 - April 2013

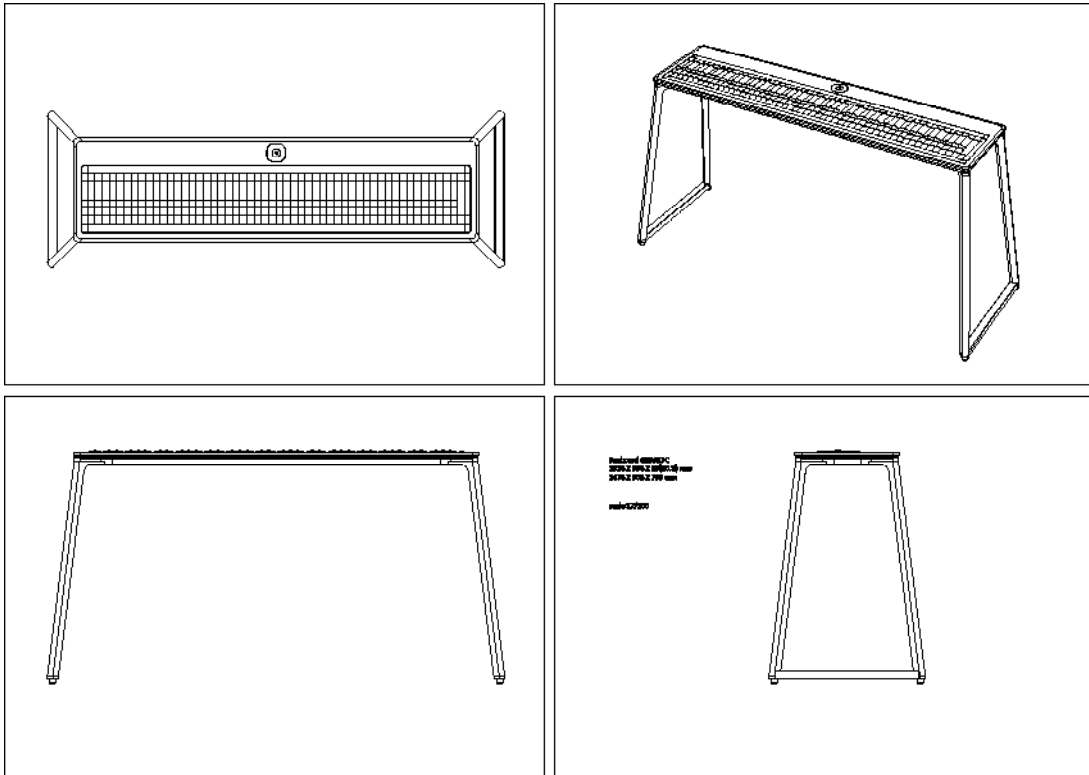

Figure 217
Seaboard GRAND C 2D drawing (multi-view)
January - July 2013

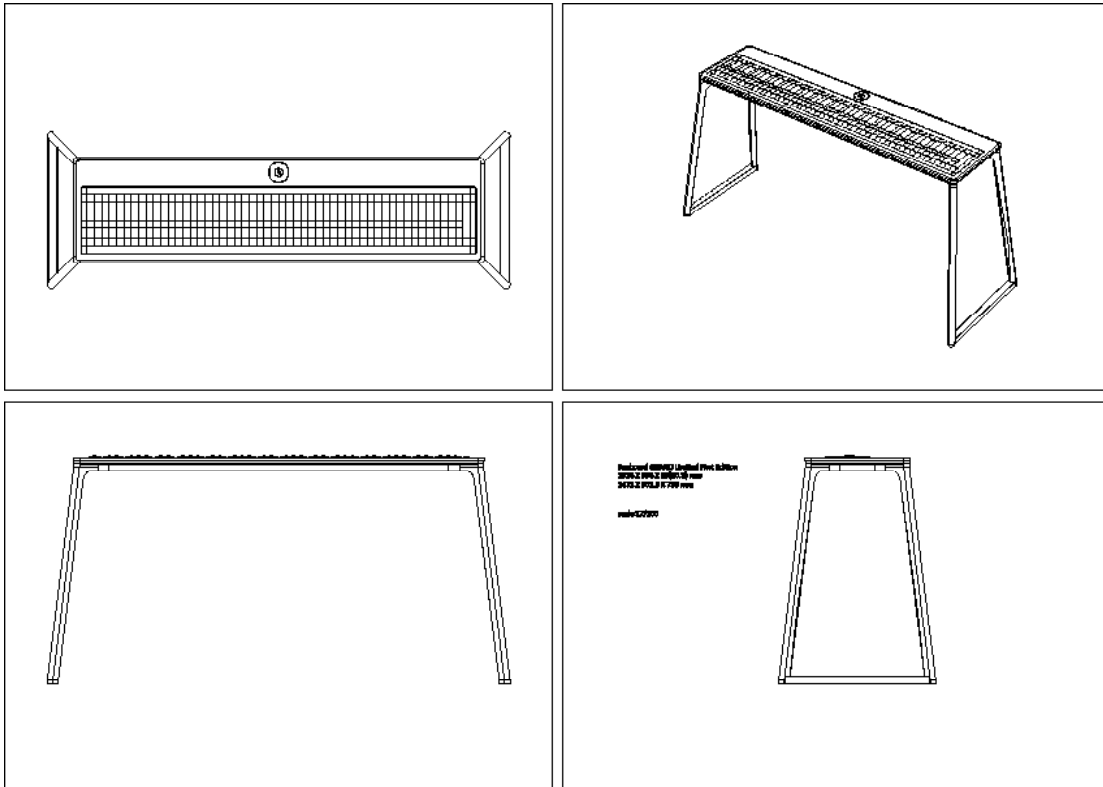

Figure 218
Seaboard GRAND LFE 2D drawing (multi-view)
April 2013 - Present (May 2014)



Figure 219

GRAND LFE, STAGE, STUDIO assembly (right perspective)

April 2013 - Present (May 2014)

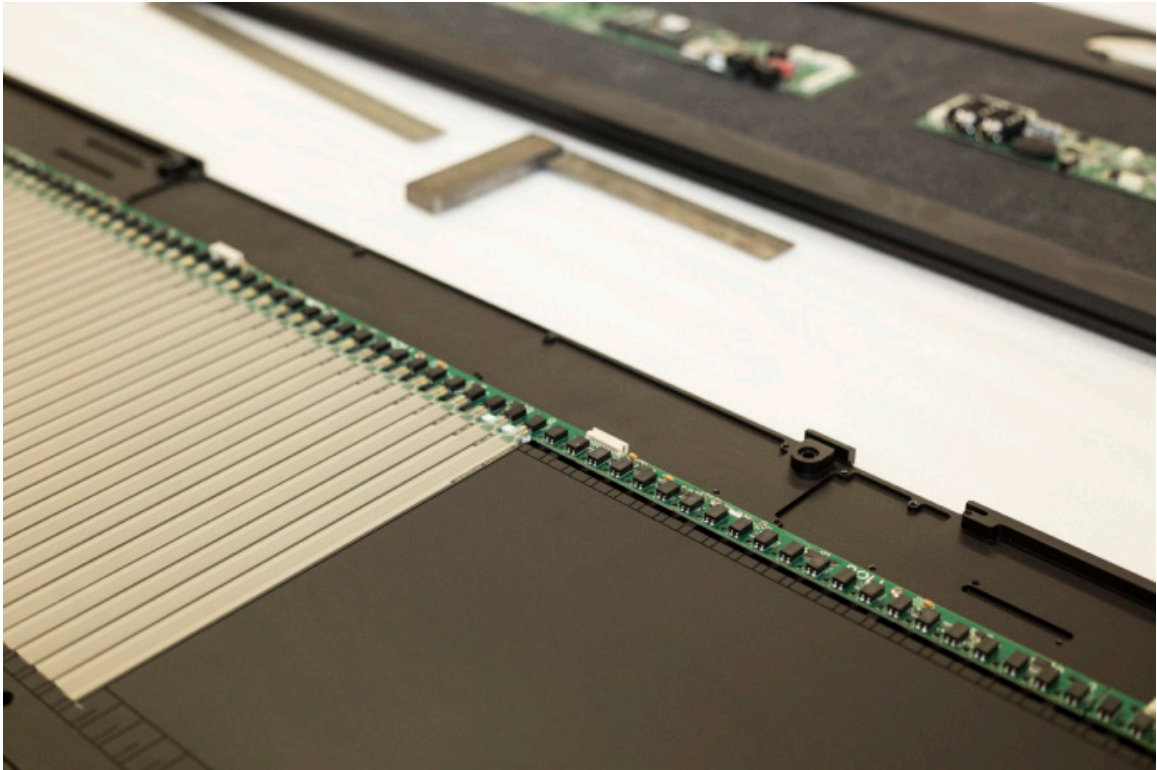

Figure 220
LFE assembly sensor alignment (right perspective detail)
April 2013 - Present (May 2014)



Figure 221

LFE assembly sensor alignment (left perspective detail)

April 2013 - Present (May 2014)



Figure 222

LFE assembly PCB (back perspective)

April 2013 - Present (May 2014)



Figure 223
Seaboard GRAND LFE (top view)
July 2013 - Present (May 2014)

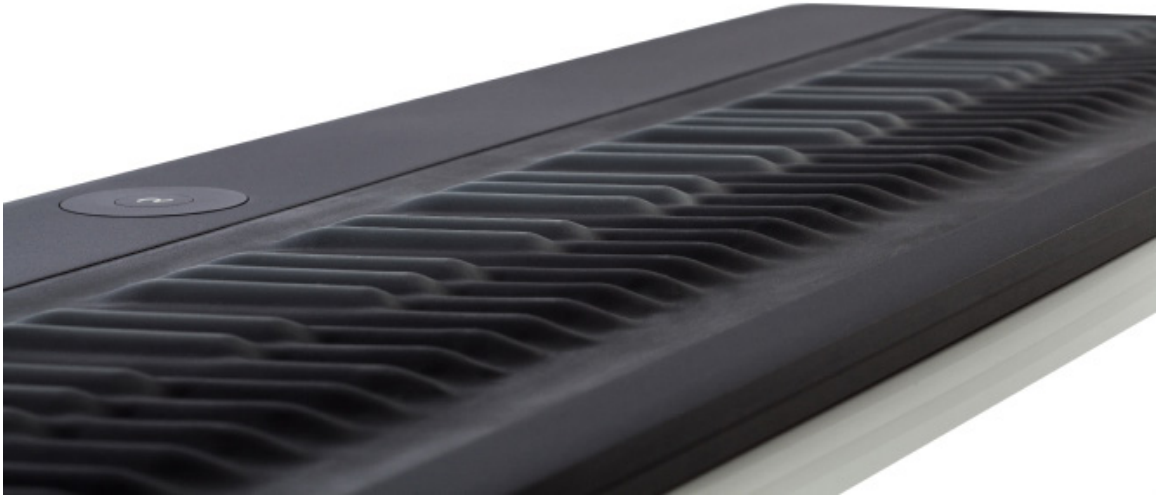

Figure 224

Seaboard GRAND LFE (left perspective detail)

July 2013 - Present (May 2014)



Figure 225

Seaboard GRAND LFE (back perspective detail)

July 2013 - Present (May 2014)

Each of the first 88 LFEs sold will have a customized back panel letter.

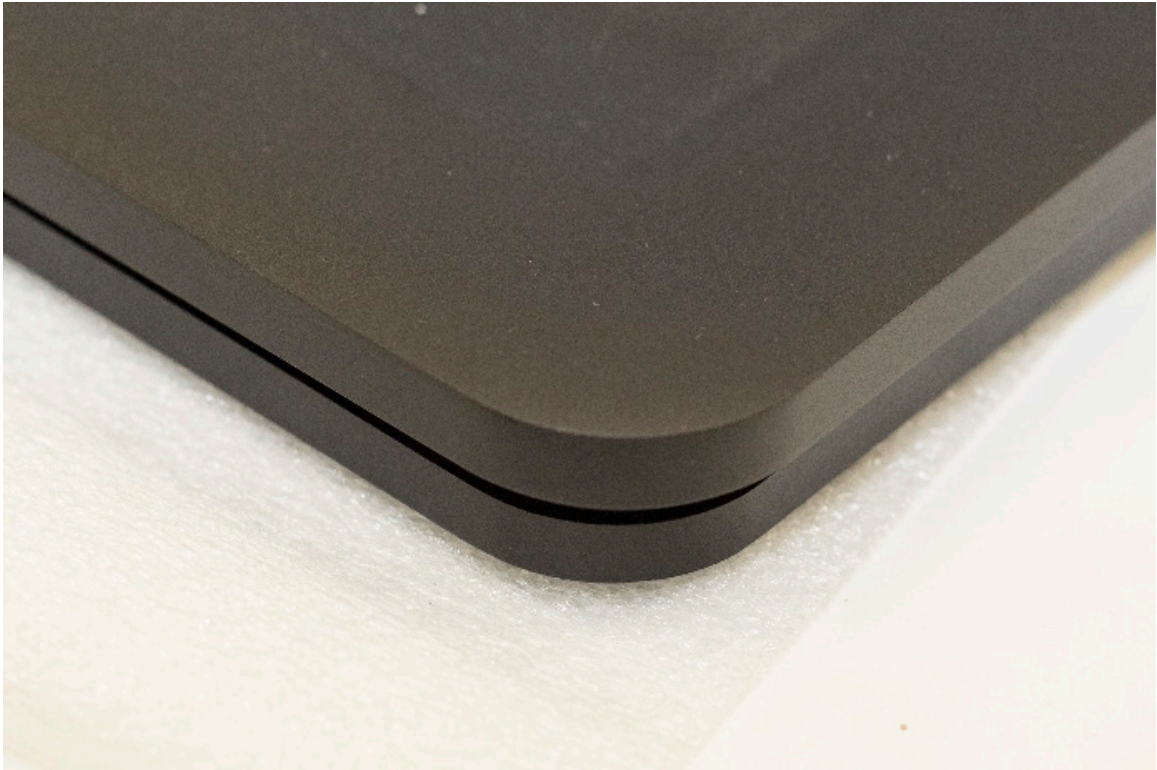

Figure 226
Seaboard GRAND LFE (chassis corner detail)
July 2013 - Present (May 2014)

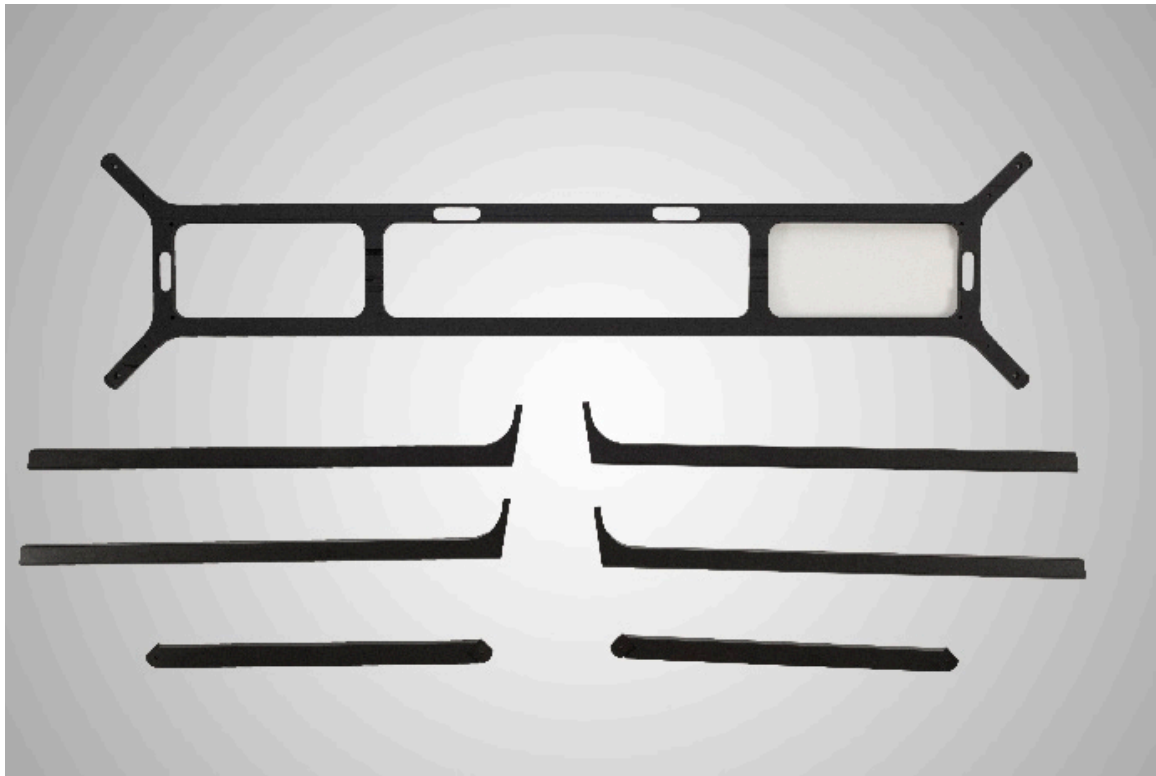

Figure 227
Seaboard GRAND LFE stand pre assembly (top view)
July 2013 - Present (May 2014)



Figure 228
Seaboard GRAND LFE stand (top view detail)
July 2013 - Present (May 2014)



Figure 229
Seaboard GRAND LFE stand (right perspective)
July 2013 - Present (May 2014)



Figure 230

Seaboard GRAND LFE and stand (front perspective detail)

July 2013 - Present (May 2014)



Figure 231
Seaboard GRAND LFE and stand (right perspective)
July 2013 - Present (May 2014)



Figure 232
Seaboard GRAND LFE and stand (front perspective)
July 2013 - Present (May 2014)



Figure 233
Seaboard GRAND LFE and stand (left perspective)
July 2013 - Present (May 2014)



Figure 234
Seaboard GRAND LFE and stand (left side perspective)
July 2013 - Present (May 2014)



Figure 235
Seaboard GRAND LFE (left perspective)
July 2013



Figure 236
Seaboard GRAND LFE (left perspective)
July 2013



Figure 237
Seaboard GRAND LFE (left perspective)
July 2013



Figure 238
Seaboard GRAND LFE (left perspective)
July 2013

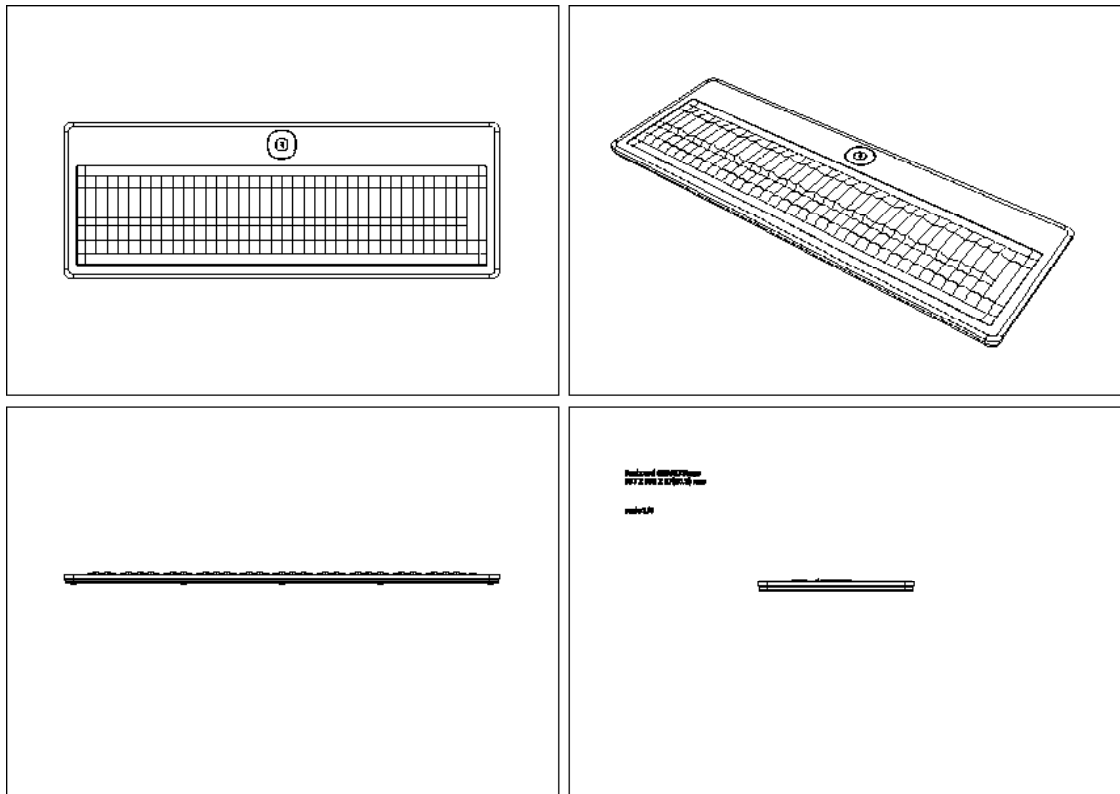

Figure 239
Seaboard GRAND STAGE 2D drawing (multi-view)
July 2013 - Present (May 2014)

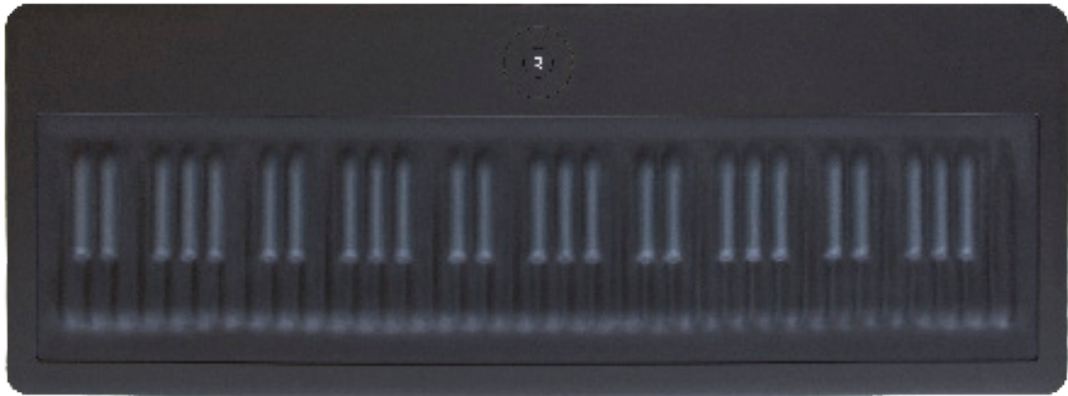

Figure 240
Seaboard GRAND STAGE (top view)
July 2013 - Present (May 2014)



Figure 241

Seaboard GRAND STAGE (front elevation)

July 2013 - Present (May 2014)



Figure 242

Seaboard GRAND STAGE (left perspective)

July 2013 - Present (May 2014)



Figure 243
Seaboard GRAND STAGE (right side perspective)
July 2013 - Present (May 2014)



Figure 244

Seaboard GRAND STAGE (back view detail)

July 2013 - Present (May 2014)



Figure 245
Seaboard GRAND STAGE in studio context (top view)
August 2013

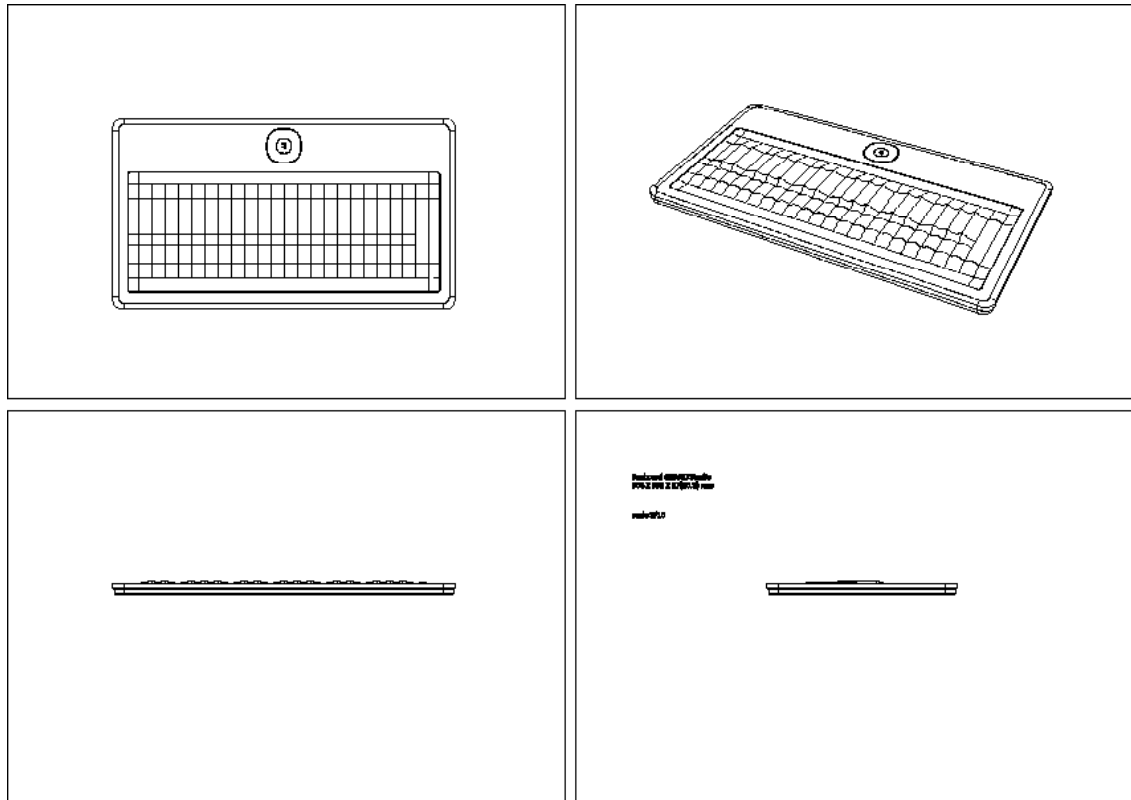

Figure 246

Seaboard GRAND STUDIO (multi-view)

July 2013 - Present (May 2014)



Figure 247
Seaboard GRAND STUDIO (top view)
July 2013 - Present (May 2014)



Figure 248

Seaboard GRAND STUDIO (right perspective)

July 2013 - Present (May 2014)



Figure 249
Seaboard GRAND STUDIO (right perspective)
July 2013 - Present (May 2014)



Figure 250

Seaboard GRAND STUDIO Sound Dial (detail)

July 2013 - Present (May 2014)



Figure 251

Seaboard GRAND STUDIO (back elevation)

July 2013 - Present (May 2014)



Figure 252

Seaboard GRAND STUDIO (back perspective)

July 2013 - Present (May 2014)



Figure 253
Seaboard GRAND STUDIO in context (right perspective)
September 2013



Figure 254

Seaboard GRAND LFE, STAGE, STUDIO Sound Dial (top view)

July 2013 - Present (May 2014)

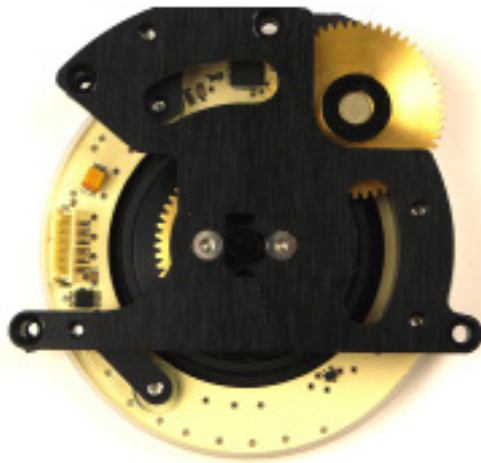

Figure 255

Seaboard GRAND LFE, STAGE, STUDIO Sound Dial (back view)

July 2013 - Present (May 2014)



Figure 256

Seaboard GRAND LFE, STAGE, STUDIO Sound Dial (face down elevation)

July 2013 - Present (May 2014)



Figure 257

Seaboard GRAND LFE, STAGE, STUDIO Sound Dial in chassis (back view)

July 2013 - Present (May 2014)

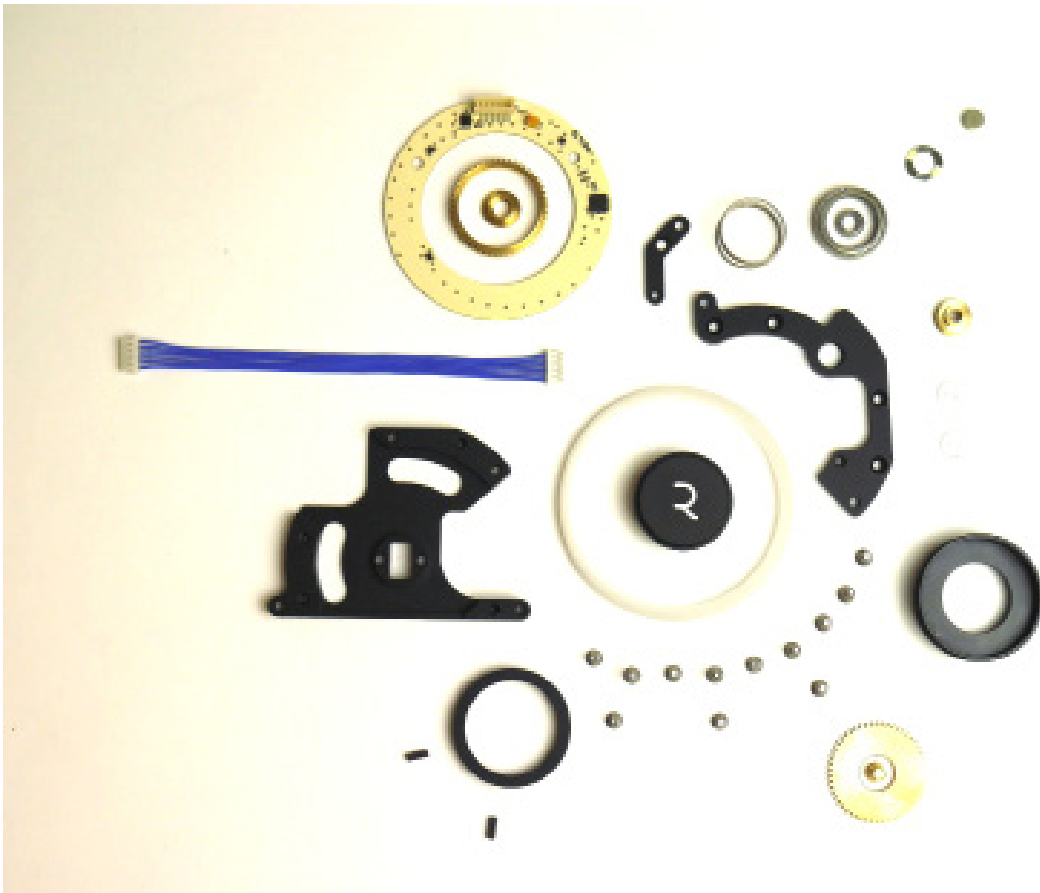

Figure 258

Seaboard GRAND LFE, STAGE, STUDIO Sound Dial pre assembly (top view)

July 2013 - Present (May 2014)

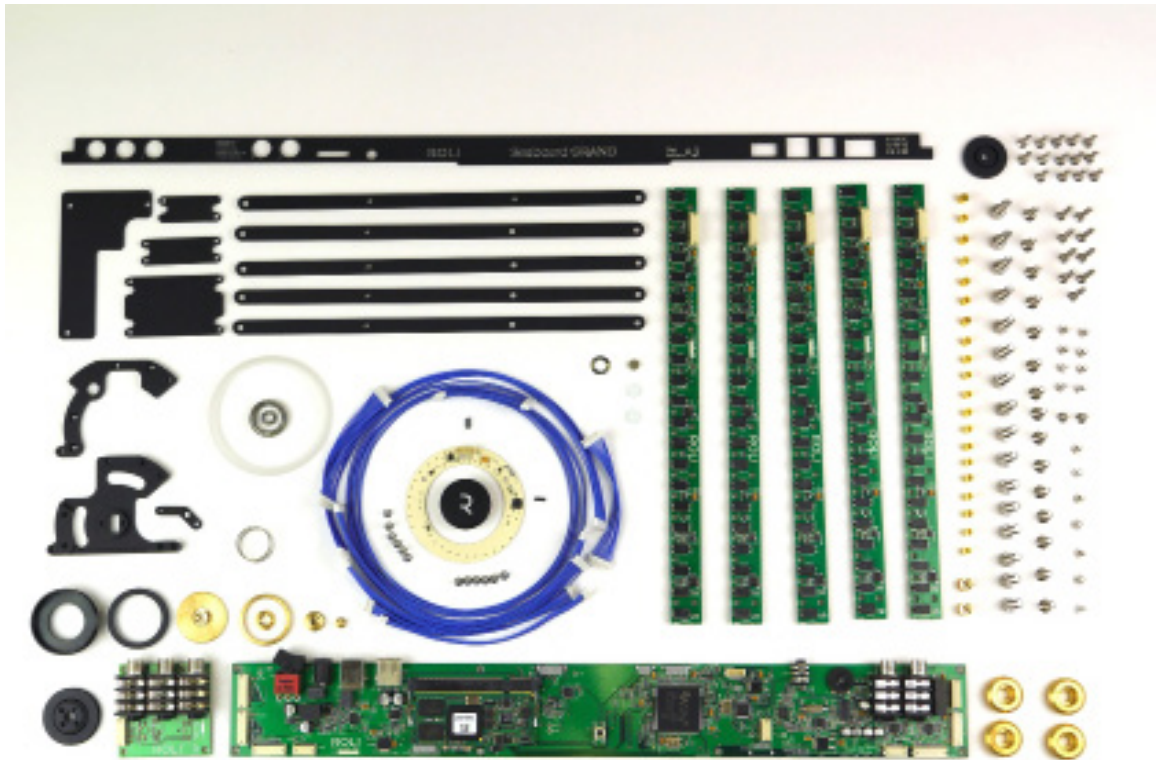

Figure 259

Seaboard GRAND LFE internal parts pre assembly (top view)

July 2013 - Present (May 2014)



Figure 260
Seaboard GRAND LFE hardware assembly tools (top view)
July 2013 - Present (May 2014)

- Left to right:
TX 20 Hexalobe
TX 15 Hexalobe
HX 15 Allen Key
HX 20 Allen Key

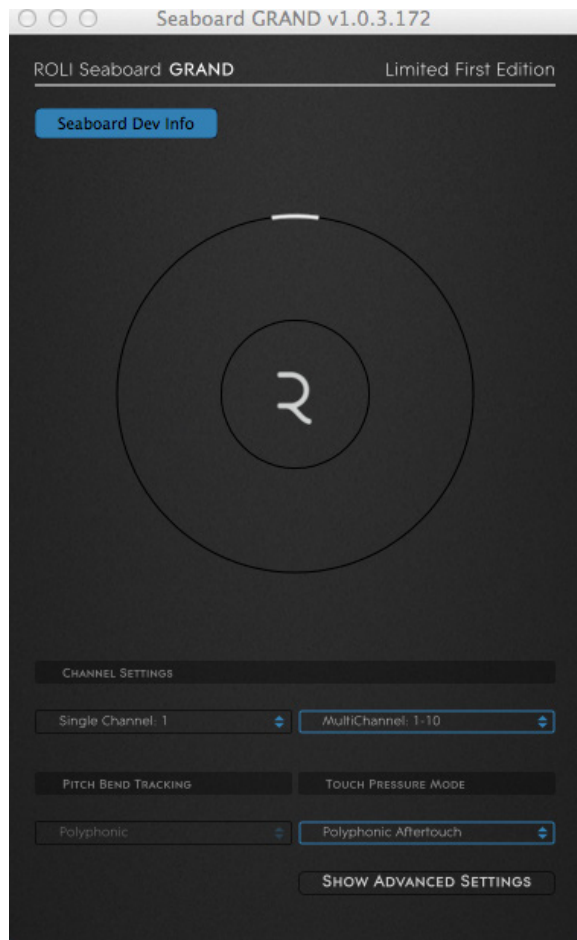

Figure 261
Seaboard GRAND Software (SGS) (screenshot)
February 2014

This is the opening screen image for the Seaboard GRAND Software (SGS) digital interface. The SGS is currently used for operating the Seaboard GRAND LFE, STAGE, and STUDIO. The Seaboard development team periodically updates the SGS features and releases the new versions to its current customers.

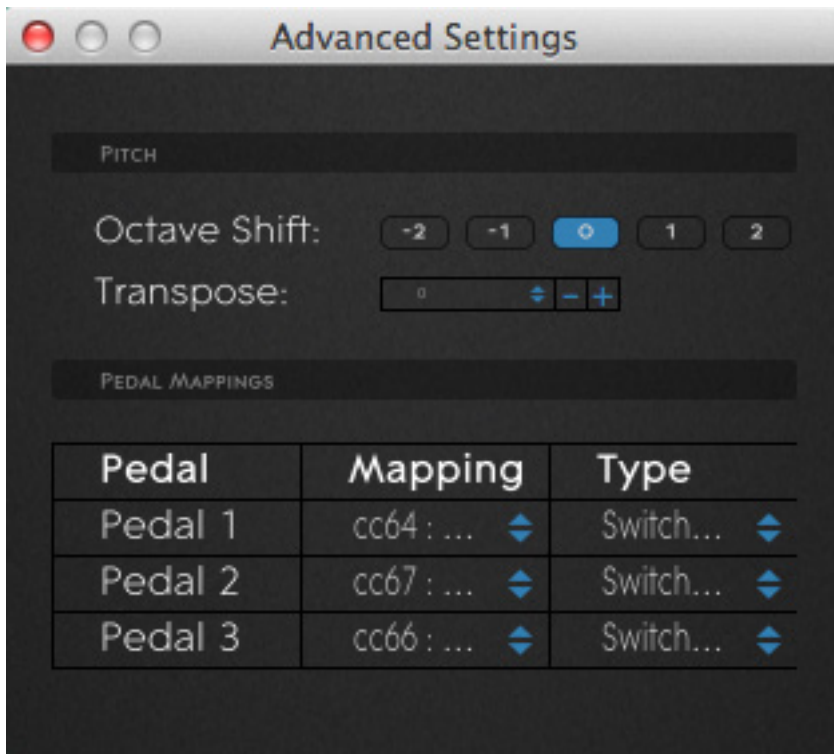

Figure 262

Seaboard GRAND Software (SGS) (screen view)

February 2014



Figure 263
Seaboard GRAND LFE EPP case (front elevation)
July 2013 - Present (May 2014)



Figure 264

Seaboard GRAND EPP case (bottom view)

July 2013 - Present (May 2014)



Figure 265
Seaboard GRAND EPP case (right perspective)
July 2013 - Present (May 2014)

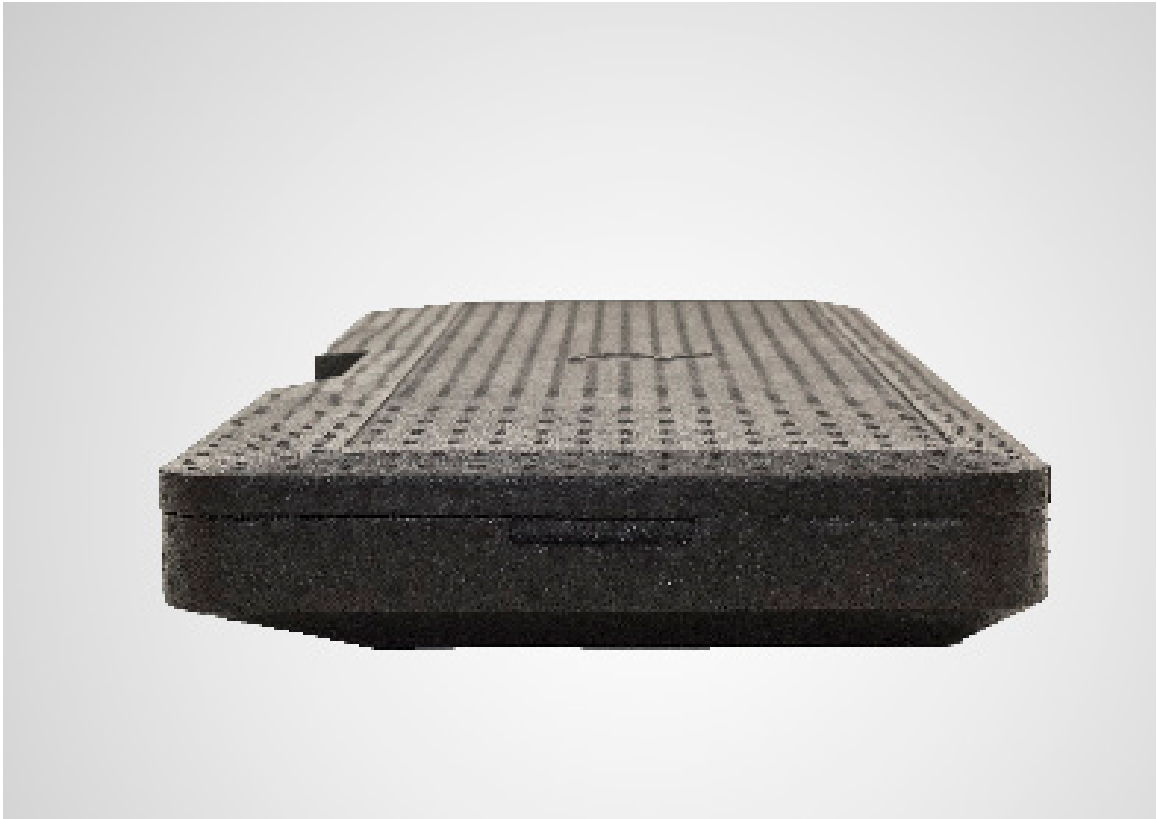

Figure 266
Seaboard GRAND EPP case (right side perspective)
July 2013 - Present (May 2014)



Figure 267

Seaboard GRAND EPP case (back elevation)

July 2013 - Present (May 2014)



Figure 268

Seaboard GRAND EPP case monogram (top view detail)

July 2013 - Present (May 2014)

The ROLI "R" logo is printed on the EPP case in 3D.



Figure 269

Seaboard GRAND EPP open case (right perspective view)

July 2013 - Present (May 2014)

The case contains a relief of the Seaboard keys in order to hold the silicone alignment in place during transport.

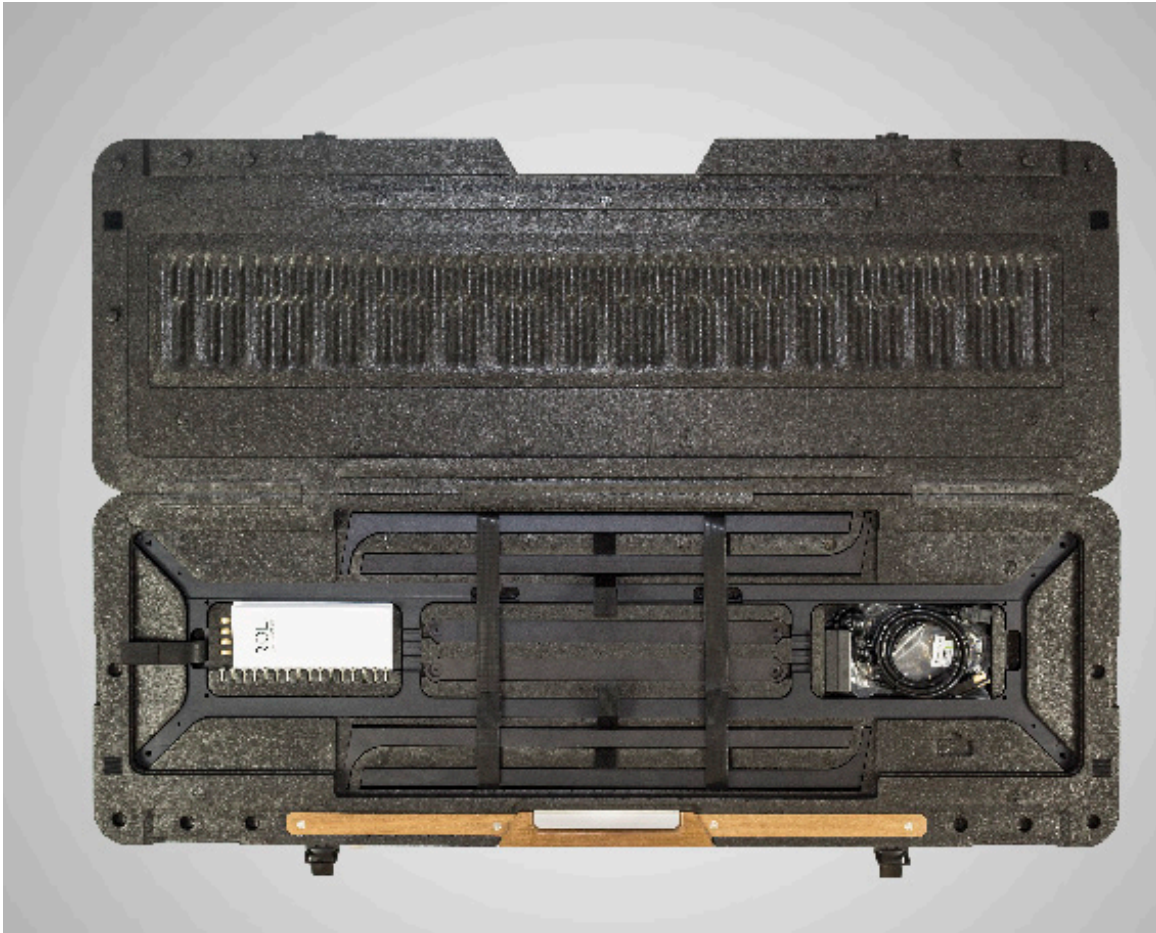

Figure 270

Seaboard GRAND EPP open case (top view)

July 2013 - Present (May 2014)

The EPP case houses the parts used for assembling and routing power to the Seaboard.



Figure 271
Seaboard GRAND EPP open case with LFE (top view)
July 2013 - Present (May 2014)



Figure 272

Seaboard GRAND EPP case fastener (right perspective detail)

July 2013 - Present (May 2014)

There are two fasteners symmetric to the handle. Once the customer opens the fastener latch, there are horizontal cavities in to the outer edge of each fastener to grab and open the case lid.



Figure 273

Seaboard GRAND EPP case handle (top left view detail)

July 2013 - Present (May 2014)

The handle is hand cut in-house.



Figure 274

Seaboard GRAND open EPP case handle (left perspective detail)

July 2013 - Present (May 2014)

The handle is manually screwed into the EPP body.



Figure 275

Seaboard GRAND EPP case interior (right perspective detail)

July 2013 - Present (May 2014)

The troughs hold the LFE stand pieces. The straps secure the LFE in place with velcro.



Figure 276

First Seaboard LFE ship day with the ROLI team

February 2014

From left to right:

Teresa Bianchi, Ben Supper, Danny White, Joe Shite, Charles Cook, Jack Armitage, Chris Fonseca, Gaetano Ling, Heen-Wah wai, Ning Xu, Julian Salaun, Tien-sheng Huang, Lauren Ianni, Roland Lamb, Silvere Letellier, Hong-yeul Eom, Rafael Szaban



Video 01

Pitch wheel demonstration

January 2010

00:00:31

Performing: Roland Lamb

Production: Roland Lamb

This video demonstrates pitch bending on an electric keyboard. The player must play a note and move the pitch wheel simultaneously to bend the pitch.

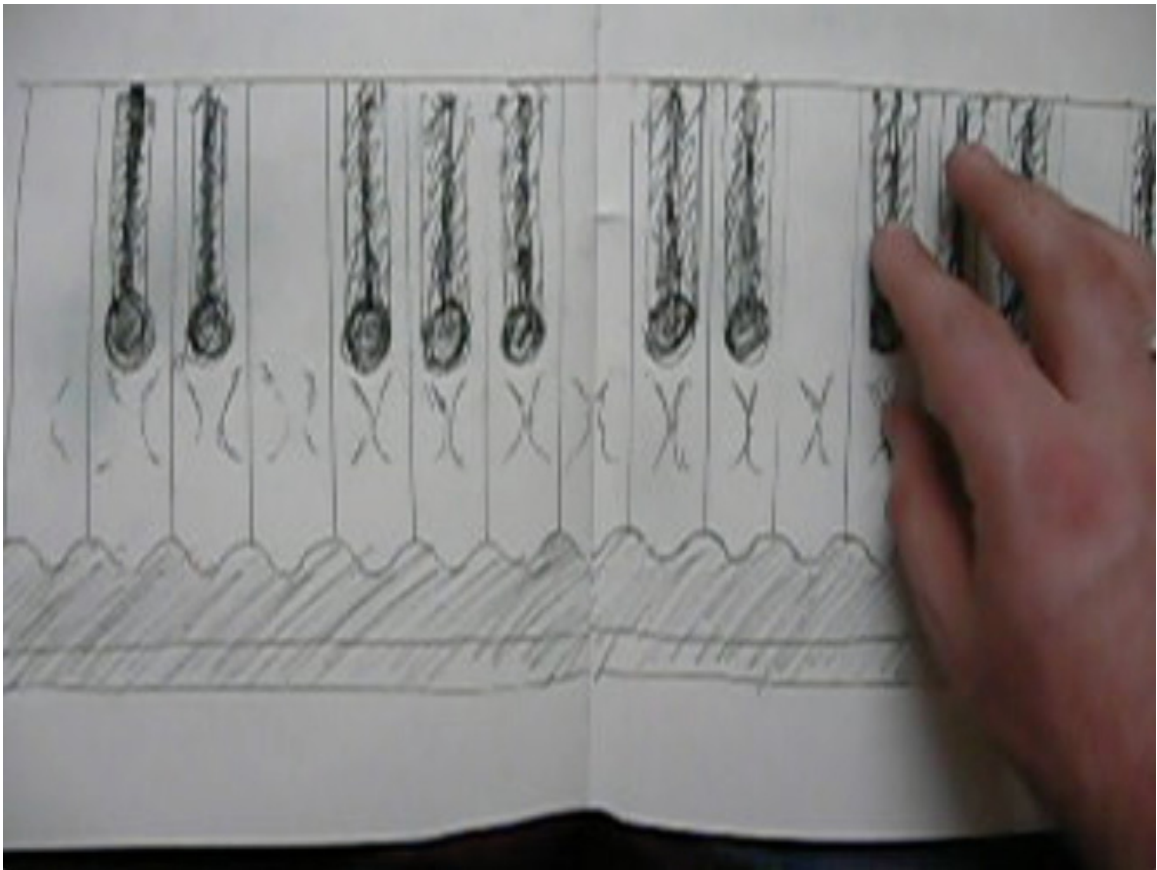

Video 02

Seaboard Interaction Concept Design

February 2009

00:00:22

Performing: Roland Lamb

Production: Roland Lamb



Video 03

Seaboard 1 simulation

May 2009

00:01:57

Performing: Roland Lamb

Production: Roland Lamb

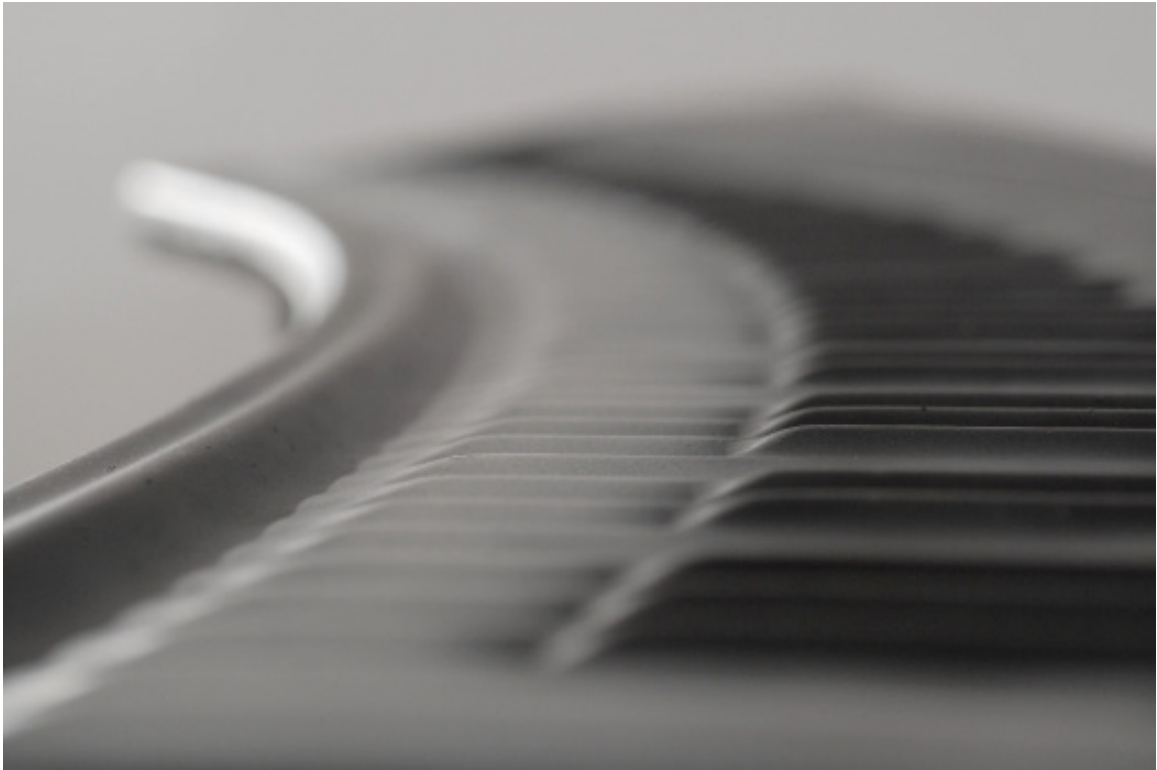

Video 04

Seaboard 1 stop motion

January 2010

00:00:14

Performing: Roland Lamb

Production: Roland Lamb



Video 05

Seaboard 2 demo

January 2010

00:01:53

Performing: Roland Lamb

Production: Roland Lamb



Video 06
Seaboard 2 with GUI demo
January 2010
00:01:49

Performing: Roland Lamb
Production: Roland Lamb

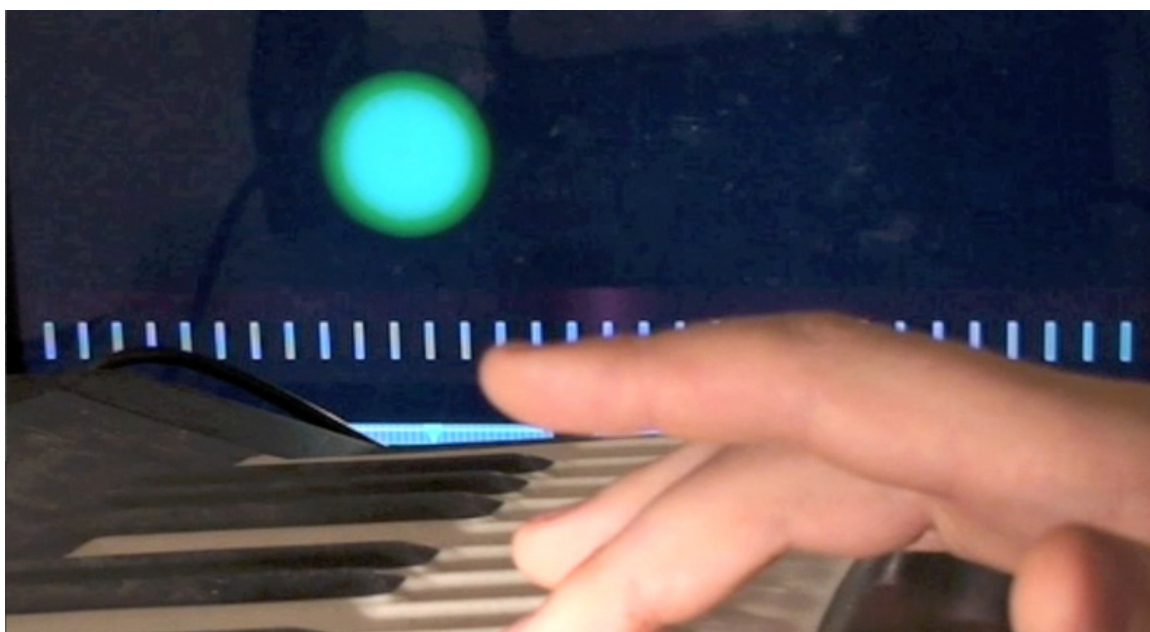

Video 07

Seaboard 2 GUI screen close up demo

January 2010

00:01:49

Performing: Roland Lamb

Production: Roland Lamb

This video presents the Seaboard 2 GUI. The GUI is a graphic which changes over time to represent changes in audio parameters. Visually, the GUI is a series of different color dots which change color and intensity based on audio modulation.



Video 08

Seaboard animated introduction

August 2010

00:01:42

Performing: N/A

Production: Sarah Beeby

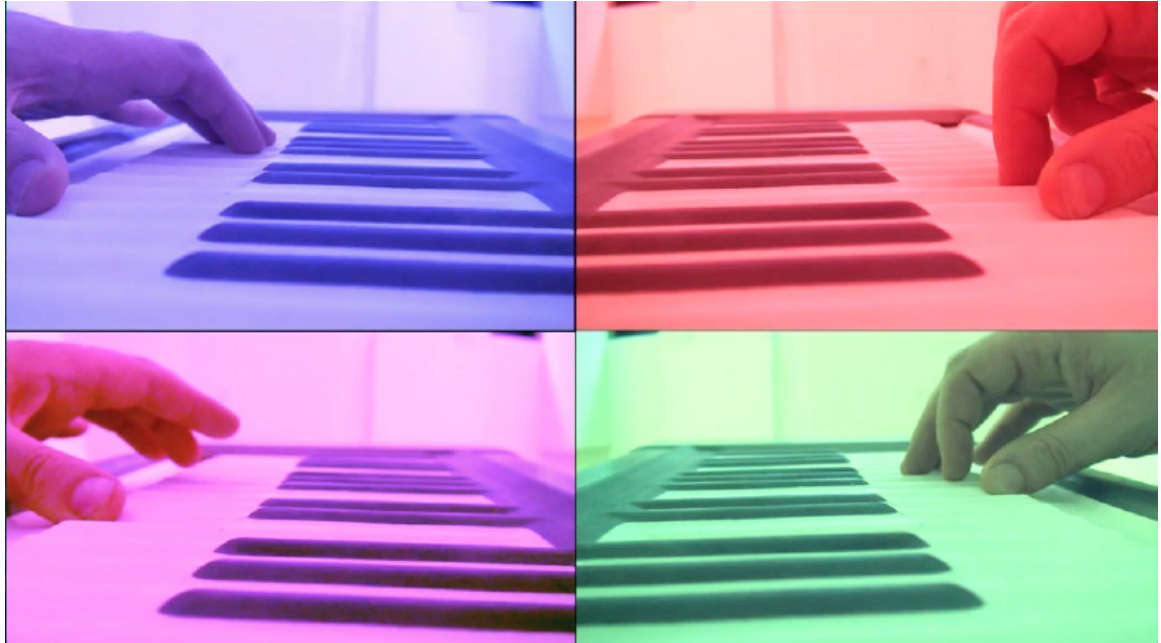

Video 09

Seaboard 3 split screen demo

August 2010

00:03:52

Performing: Roland Lamb

Production: Roland Lamb



Video 10

Michael Price interview

November 2010

00:02:24

Performing: Michael Price

Production: Roland Lamb



Video 11

Seaboard 3 and electronic chromatic chords

May 2011

00:03:28

Performing: Heen Wah-Wai, Luke Barlow, Irfan Hasan, Dean McCormick, Kishon Khan,
Production: Roland Lamb



Video 12

Seaboard 3 demo

May 2011

00:00:40

Performing: Roland Lamb

Production: Roland Lamb

This demonstrates the overall playability of the Seaboard 3. The right hand slides along keywaves to create pitch bends throughout the performance, and the left hand makes use of the pitch ribbon at the end of the performance. The hands sink in and out of the keywaves towards the end of the video, which morphs the sound between a clean Rhodes to a drive-guitar sound.



Video 13

Seaboard 3 development and impact

May 2011

00:03:28

Performing: Heen Wah-Wai, Luke Barlow, Irfan Hasan, Dean McCormick, Kishon Khan,
Production: Roland Lamb



Video 14

Seaboard 3 Pather Panchali

May 2011

00:00:47

Performing: Roland Lamb

This demonstrates the Seaboard simulating a Bansuri flute and sitar with a split on the Seaboard 3.



Video 15

Seaboard 3 Summertime

June 2011

00:01:22

Performing: Roland Lamb

This is a live performance of "Summertime" on the Seaboard, with an EP sound. Throughout the performance you can see the hands adding vibratos to individual notes and creating volume swells by pressing hard into the keywave.



Video 16

Seaboard 3 Chopin performance

June 2011

00:01:22

Performing: Heen-Wah Wai

This demonstrates using the Seaboard to simulate an acoustic guitar. Techniques such as pitch bend and vibratos are used throughout the video.



Video 17

Kunihiro Takei interview

December 2011

00:01:22

Performing: Heen-Wah Wai



Video 18

Seaboard Canon Advert

May 2012

00:01:03

Performing: Heen-Wah Wai

This video shows off how the way you could simulate a variety of instruments on the Seaboard. It also highlights a range of core technique for playing the Seaboard including vibrato, ribbon bend and continuous-touch control. The quality and the arrangement of the sound is not world class as it was produced during the pre-ROLI period, when resources were limited. However, it highlights very clearly the functionality and vision for what the Seaboard is, and will become.



Video 19

Jordan Rudess Seaboard LUTE demo

March 2013

00:00:19

Performing: Jordan Rudess

Production: Jordan Rudess

A short clip of Jordan Rudess playing an interesting synthesized sound on the Seaboard.



Video 20

Imagining the Seaboard

November 2013

00:02:27

Performing: Heen-Wah Wai

Production: TJ Hellmuth, Lily Skove



Video 21

Crafting The Seaboard

November 2013

00:02:45

Performing: N/A

Production: TJ Hellmuth, Lily Skove



Video 22

Exploring the Seaboard

April 2013

00:02:33

Performing: Roland Lamb

Production: TJ Hellmuth, Lily Skove



Video 23

Introducing the Seaboard

November 2013

00:00:59

Performing: The ROLI Team

Production: TJ Hellmuth, Lily Skove

This demonstrates the Seaboard being used to simulate a double bass and a Hybrid Rhodes sound. The double bass part involves using the pitch ribbon, and the Rhodes parts shows off the possibilities polyphonic pitch bend enables.



Video 24

Jamie Cullum and the Seboard GRAND

August 2013

00:17:58

Performing: Jamie Cullum, Roland Lamb

Production: RiffRaff Films



Video 25

Seaboard GRAND performance (Moonwalk)

November 2013

00:00:41

Performing: Heen Wah-Wai, Roland Lamb

Production: TJ Hellmuth, Lily Skove

The video showcases the seaboard enabling polyphonic pitch bend, where the pitch of each triggered note is independent from other notes. It also demonstrates the use of the pitch ribbons through the 'moonwalk' gesture.



Video 26

Seaboard GRAND performance (Prokofiev)

November 2013

00:00:45

Performing: Hao Chen

Production: TJ Hellmuth, Lily Skove

This video demonstrates how the Seaboard can be used to play fast, highly technical piano pieces.



Video 27

Seaboard GRAND performance (Percussion)

November 2013

00:01:01

Performing: Heen-Wah Wai

Production: TJ Hellmuth, Lily Skove

This demonstrates the subtle use of semitone and wholetone pitch bend.



Video 28

Seaboard GRAND performance (Satie)

November 2013

00:01:38

Performing: Hao Chen

Production: TJ Hellmuth, Lily Skove

This video demonstrates subtle uses of pitch bend. Continuous touch is mapped to the rate of the bells at the background, whereby the harder you press, the faster the rate is. This feature helps the performer to create interesting soundscapes simply through intuitive keyboard-like playing techniques.



Video 29

Seaboard GRAND performance (Starfield)

November 2013

00:00:00

Performing: Roland Lamb

Production: TJ Hellmuth, Lily Skove

This video demonstrates subtle uses of pitch bend and the ways in which the performer might use continuous touch to access deeper sound layers.



Video 30

Seaboard GRAND performance (Mystic)

November 2013

00:01:33

Performing: Roland Lamb

Production: TJ Hellmuth, Lily Skove



Video 31

Seaboard GRAND performance (Naima 1)

March 2013

00:02:16

Performing: Roland Lamb

Production: TJ Hellmuth, Lily Skove

This is a live performance on the Seaboard. It uses a layered sound combining a piano and a pad on the continuous-touch. It highlights one of the extended technique at the end of the video, where octave gestures are used between both hands to create a smooth pitch bend of 2 notes an octave apart.



Video 32

Seaboard GRAND performance (Naima 2)

November 2013

00:02:25

Performing: Roland Lamb

Production: TJ Hellmuth, Lily Skove



Video 33

Hans Zimmer and the Seaboard CNN Feature

December 2013

00:01:10

Performing: Hans Zimmer

Production: CNN



Video 34

Cory Henry demonstrates the Seaboard GRAND LFE at NAMM

January 2014

00:01:09

Performing: Cory Henry

Production: TJ Hellmuth, Lily Skove



Video 35

Rob Gentry demos the Seaboard at IRCAM

January 2014

00:03:40

Performing: Rob Gentry

Production: Jean-Baptiste Thiebaut



Video 36

ROLI SoundHive Featured Artist Session 1

October 2013

00:02:38

Performing: Rachel Sermanni, Jennifer Austin

Production: Santiago Ortega, Julian Salaun

This is the first video produced from our SoundHive session series, starring Rachel Sermanni on voice and guitar, and Jennifer Austin on the Seaboard. The sound on the Seaboard has a bell-like sound on the attack and pads on the continuous-touch.

Audio 01

A Bending Rhodes

September 2010

00:01:48

Performing: Heen Wah-Wai

Production: Heen Wah-Wai

This features track many instances of polyphonic pitch bend, but no usage of continuous touch.

Audio 02

Blackbird

August 2011

00:01:18

Performing: Heen-Wah Wai

Production: Heen-Wah Wai

This is a recording of a live performance on the Seaboard 3. The sound was created when first experimenting with layering samples. In this case, an electric guitar is layered on top of a Rhodes.

Audio 03

Mozart alla Turca

August 2011

00:00:27

Performing: Heen-Wah Wai

Production: Heen-Wah Wai

This demonstrates the Seaboard being used to play classical music, with an augmented instrument - a Clavichord where pitch is not fixed and is bendable.

Audio 04

Chopin Nocturne in C

September 2011

00:00:46

Performing: Heen-Wah Wai

Production: Heen-Wah Wai

This demonstrates a classical piece by Chopin (Piano Nocturne in C) being played on the Seaboard, with another pitched percussive sample.

Audio 05

Amelie

December 2012

00:01:30

Performing: Heen-Wah Wai

Production: Heen-Wah Wai

This is a recording of a live performance on a Seaboard GRAND B. The synthesized sound is designed such that continuous touch affects the filter cutoff of the patch.

Audio 06

Mysterious

January 2013

00:01:03

Performing: Heen-Wah Wai

Production: Rafael Szaban, Heen-Wah Wai

This demonstrates the Seaboard being used in a production context. The track consists of several layers, where each layer explores different characteristics that the Seaboard enables.

Audio 07
Coltrane
February 2013
00:02:26

Performing: Roland Lamb
Production: Rafael Szaban, Heen-Wah Wai

This is a live performance on the Seaboard. It uses a layered sound combining a piano and a pad on the continuous-touch.

Audio 08
Bellatrix
April 2013
00:00:46

Performing: Heen-Wah Wai
Production: Rafael Szaban, Heen-Wah Wai

This is a recording of a live performance on a Seaboard GRAND LFE. Continuous touch is mapped to the speed of the looped envelope, increasing its rate as more pressure is applied.

Audio 09
Classical Guitar
April 2013
00:00:21

Performing: Heen-Wah Wai
Production: Rafael Szaban, Heen-Wah Wai

This demonstrates the Seaboard simulating an acoustic guitar with fast, staccato expressions.

Audio 10
Percussive Variation
April 2013
00:01:46

Performing: Heen-Wah Wai
Production: Rafael Szaban, Heen-Wah Wai

This demonstrates the Seaboard being used in a production context. The track consists of several layers, and continuous touch is used throughout to bring the pad layer in and out of the overall soundscape.

Audio 11
Western Fusion
May 2013
00:01:35

Performing: Heen-Wah Wai
Production: Rafael Szaban, Heen-Wah Wai

This demonstrates the Seaboard being used to simulate a Western guitar.

Audio 12
Fairy Loop
June 2013
00:00:59

Performing: Heen-Wah Wai
Production: Rafael Szaban, Heen-Wah Wai

This demonstrates how the Seaboard can create rich and complex soundscapes.

Audio 13
African Fantasy
July 2013
00:02:08

Performing: Heen-Wah Wai
Production: Rafael Szaban, Heen-Wah Wai

This is a recording of a live performance on a Seaboard GRAND B. The synthesized sound is arpeggiated when each note is sustained.

Audio 14
Fretless
August 2013
00:00:54

Performing: Jordan Rudess
Production: Jordan Rudess

This demonstrates one of the core features of the Seaboard - polyphonic pitch bend, where individual notes can have their own pitch bent without affecting other active notes.

Audio 15

India

August 2013

00:00:58

Performing: Jordan Rudess

Production: Jordan Rudess

This demonstrates the Seaboard being used to simulate Eastern-influenced microtonal musical instruments. This piece involves playing notes that are outside of the Western 12-tone scale, making the Seaboard ideal for simulating instruments beyond those of the traditional Western orchestra.

Audio 16

Sahara Dream

August 2013

00:00:56

Performing: Jordan Rudess

Production: Jordan Rudess

This demonstrates the Seaboard simulating a plucked instrument. It shows how quickly you can retrigger the same note, much quicker than you would be able to on a regular keyboard.

Audio 17
Slide Guitar
August 2013
00:00:56

Performing: Jordan Rudess
Production: Jordan Rudess

This demonstrates the Seaboard simulating a guitar-like sound. It begins with a monophonic line, highlighting the pitch bend aspect of the Seaboard. It then introduces other notes for accompaniment, demonstrating the polyphonic pitch bend enabled feature of the Seaboard.

Audio 18
Wudan Path
August 2013
00:00:42

Performing: Heen-Wah Wai
Production: Rafael Szaban, Heen-Wah Wai

This is a live performance on the Seaboard. It demonstrates how pitch bends can be used in a subtle context, and also how it is also possible to play fast runs on the Seaboard.

Audio 19
Claire de Lune
September 2013
00:01:42

Performing: Heen-Wah Wai
Production: Rafael Szaban, Heen-Wah Wai

This demonstrates a classical piece, Clair de Lune by Debussy, performed live on a Seaboard. The sound used in the track is by far the most layered and interesting sound we yet created at ROLI. It requires setting up 52 MIDI channels and involves multiple CPU intensive soft synth plugins including Omnisphere, Kontakt and Zebra. Playing lightly on top of the keywaves of the Seaboard triggers a light plucked instrument initially; then as you sink your fingers into the keywaves, rich orchestral layers float into the mix. Along with a few decorative pad layers, the sound grows into a beautiful soundscape as the piece progresses.

Audio 20
Nostalgic Afterthought
January 2014
00:01:54

Performing: Heen-Wah Wai
Production: Rafael Szaban, Heen Wah-Wai

This demonstrates the Seaboard being used to simulate a jazz guitar.

Audio 21

Drive

February 2014

00:01:39

Performing: Heen-Wah Wai

Production: Rafael Szaban, Heen-Wah Wai

This demonstrates the Seaboard used in a progressive rock context. The bass part includes pitch bends of various bend ranges, which is very difficult to achieve accurately using a pitch wheel. The pad layers preserve interesting motions through the use of polyphonic continuous touch, where the character of each note within a chord is continuously modulated with variation in pressure and pitch. The lead solo demonstrates how a performer can incorporate expressive pitch bends into a fast and technical solo.

Audio 22

Decryption

March 2014

00:03:42

Performing: Heen-Wah Wai

Production: Rafael Szaban, Heen Wah-Wai

This demonstrates the Seaboard used in a more contemporary house music context. The track was heavily layered and produced, where each sound shows off a particular aspect of the Seaboard. Notable musical features to listen out for include glissando in the bassline, LFO rate variations on the pitch ribbon, and subtle glitches on the drumbeat throughout the piece.

Audio 23
Eruption Guitar Solo
March 2014
00:00:22

Performing: Heen-Wah Wai
Production: Rafael Szaban, Heen-Wah Wai

This demonstrates the Seaboard simulating an electric guitar. This is a transcription of the guitar solo of a song "Eruption", which involves expressive pitch bends.

Audio 24
Mellow Horn
March 2014
00:00:52

Performing: Heen-Wah Wai
Production: Rafael Szaban, Heen-Wah Wai

This demonstrates the Seaboard being used to simulate a small brass ensemble. The piece can be divided into two parts: the melody and the accompaniment. The melody consists of a number of lazy-sounding pitch bends, and the accompaniment is played in a more legato way to enable continuous touch on the Seaboard.

Audio 25

Acoustic Piano

April 2014

00:00:36

Performing: Heen-Wah Wai

Production: Rafael Szaban, Heen-Wah Wai

This track demonstrates how one might play traditional piano samples on a Seaboard GRAND LFE.

Audio 26

Clarinet Rhapsody in Blue

April 2014

00:00:14

Performing: Heen-Wah Wai

Production: Rafael Szaban, Heen-Wah Wai

This demonstrates the Seaboard simulating a reed instrument. It showcases the amount of fine control a performer can have over the pitch.

Audio 27
Fusor Dynamic EP
April 2014
00:00:54

Performing: Heen-Wah Wai
Production: Rafael Szaban, Heen-Wah Wai

This demonstrates one of the core features of the Seaboard - polyphonic pitch bend, where individual notes can have their own pitch bends without affecting other active notes.

Audio 28
Horizon
April 2014
00:02:24

Performing: Heen-Wah Wai
Production: Rafael Szaban, Heen-Wah Wai

This demonstrates the Seaboard being used to produce film music. The sound is created by combining sampled and synthesized sounds. Samples have great sounding characteristics on their attacks, whereas synthesized sounds respond better to modulations through pitch bend and continuous touch.

Audio 29
Tears In The Rain
April 2014
00:03:10

Performing: Heen-Wah Wai
Production: Rafael Szaban, Heen-Wah Wai

This demonstrates the Seaboard being used to create substantial orchestral sounds.

Audio 30
Dirt Ribbon
April 2014
00:00:42

Performing: Marco Parisi
Production: Rafael Szaban

This is a short piece performed live on the Seaboard using the "Dirt Ribbon" preset from Fusor.

Audio 31
Flute
April 2014
00:00:29

Performing: Marco Parisi
Production: Rafael Szaban

This demonstrates the Seaboard being used to simulate a flute through Sample Modeling.

Audio 32
Jazz Guitar
April 2014
00:00:41

Performing: Marco Parisi
Production: Rafael Szaban

This demonstrates the Seaboard being used to simulate a jazz guitar performance.

Audio 33

Oboe

April 2014

00:00:51

Performing: Marco Parisi

Production: Rafael Szaban

This demonstrates the Seaboard realistically simulating an oboe sample through Sample Modelling.

Audio 34

Upright Bass

April 2014

00:01:01

Performing: Marco Parisi

Production: Rafael Szaban

This demonstrates the Seaboard being used to simulate an upright double bass.

Appendix D. Research timeline

Prototype & Product Development

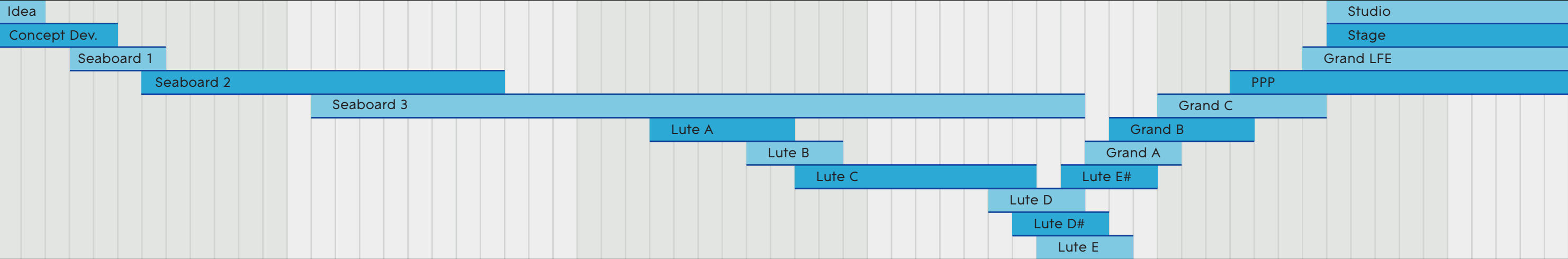

Component Development

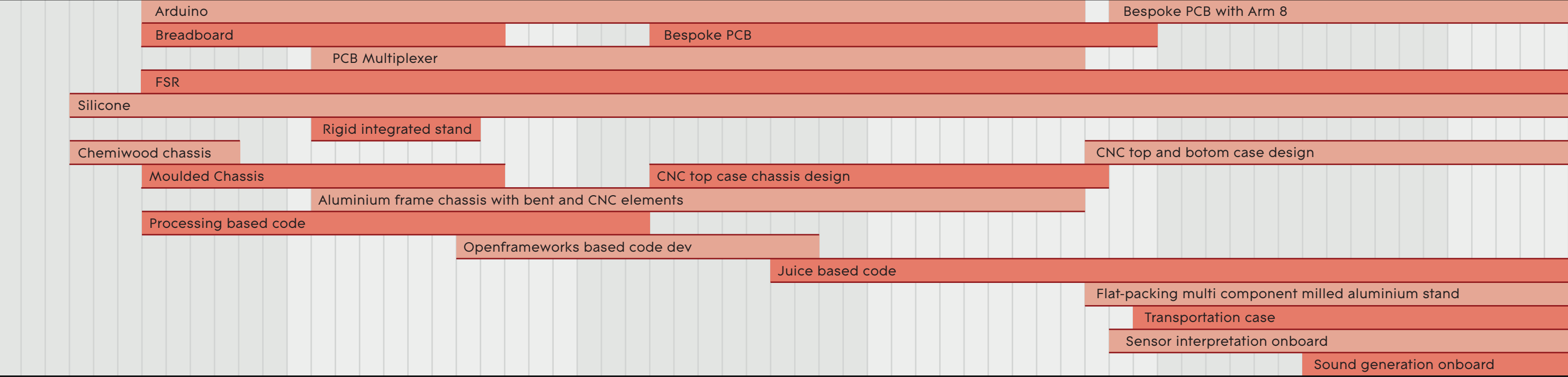

Key Events

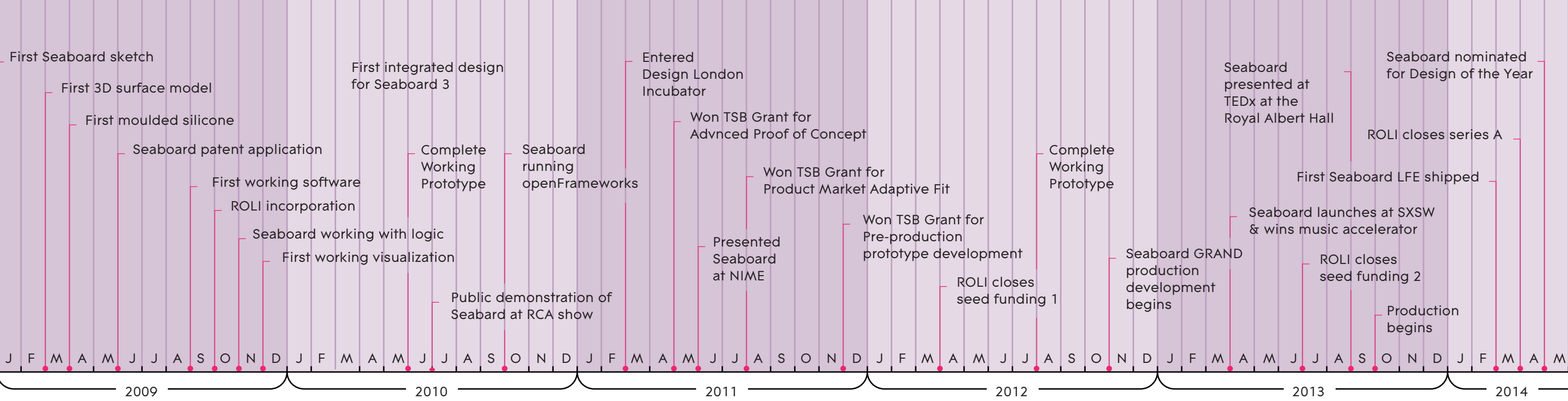

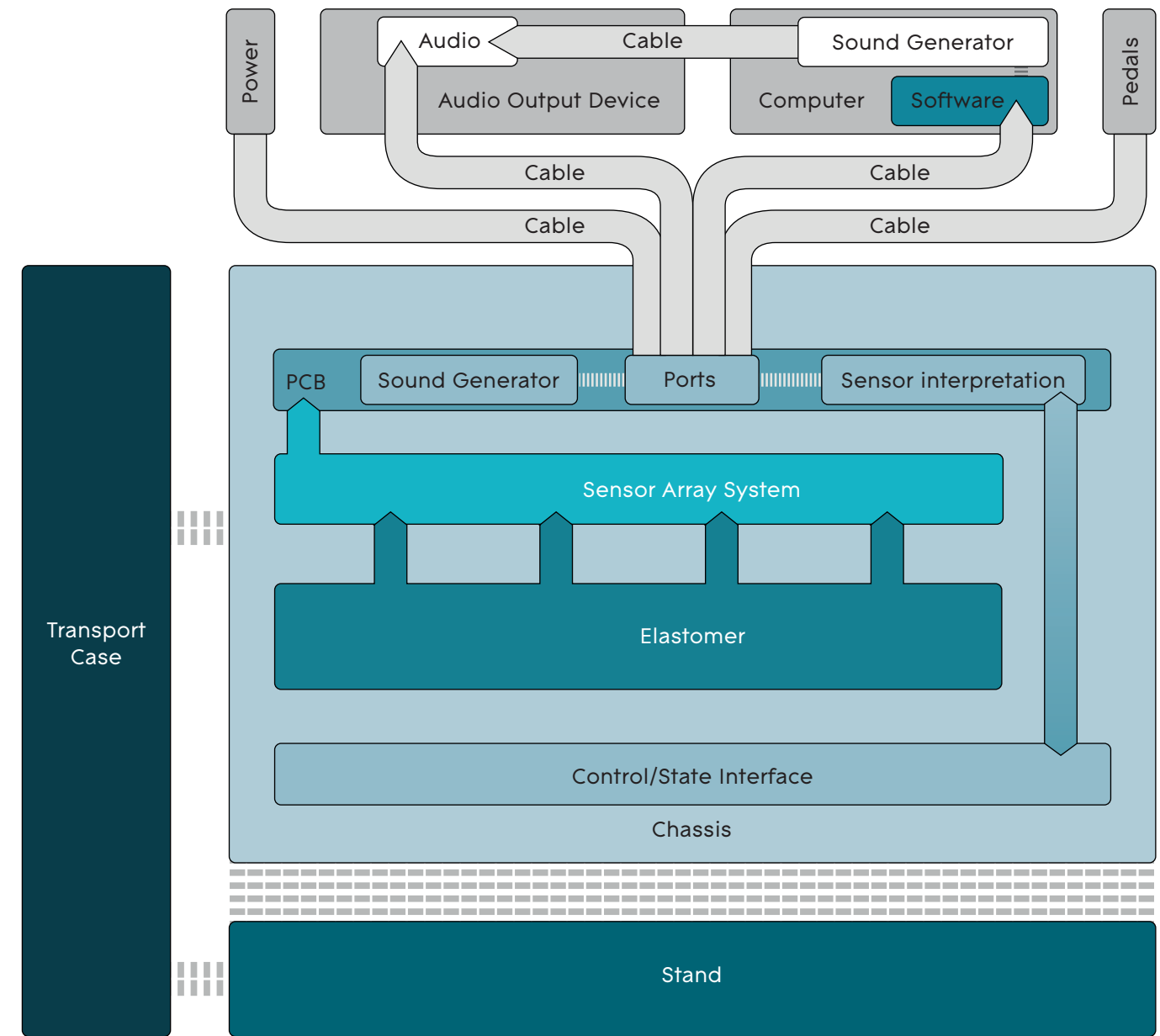
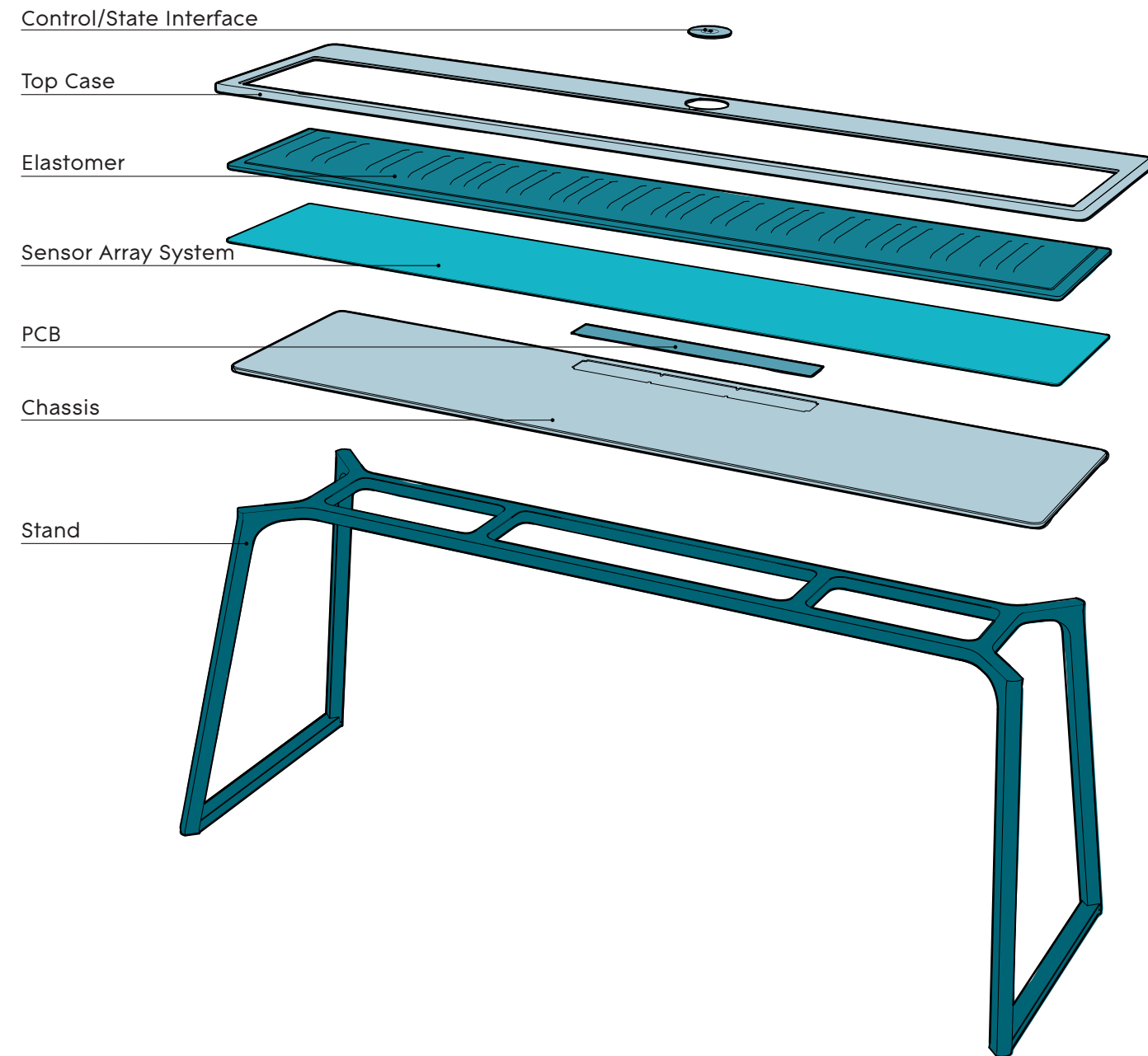

Key Definitions

- Elastomer:** The elastomer is the pliable body that makes up the top interaction surface, and translates forces onto (or into) the sensor system.
- Sensor System:** The sensor system detects the forces applied onto it via the elastomer, and transmits this analogue data to the PCB.
- Sensor Interpretation:** To process the analogue sensor data into digital data, and in some cases for many other operations including communication with the control/state interface, Seaboards require electronics and firmware.
- Control/State Interface:** Most working Seaboard systems will have some form of control/state interface. Depending on the exact system there a wide range of possible requirements for this – the two most minimal include a power on/off button of some kind, and power state indicator, like a LED light.
- Software:** When connected to computers, Seaboards need some form of software to control various settings and parameters.
- Chassis:** The chassis is the main enclosure which holds the elastomer, sensor system, PCB/Ports and Control/State interface rigidly together and provides structural stability. It can sit on a stand where applicable.
- Sound generation:** Once note data, in whatever format, has been created, Seaboards need to utilise some form of sound generation, e.g. sample playback, a synthesis engine, which could run on an embedded system, a computer or hardware synth.
- Ports:** Most possible Seaboards will have ports of some kinds, connecting the PCB to a power source, audio output device, or external computer.

- PCB:** The PCB accepts the data from the sensor system, and, depending on the system configurations, either simply turns the analogue data into digital data and passes the data onto a computer, or further processing of the data and sound generation can take place on board.
- Cover:** Seaboards do not require covers but when left set up in a home environment covers are sometimes used to prevent dust.
- Cables:** In most cases cables of some kind will be necessary to the function of the Seaboard. Given the particular ambition to create the feeling of an acoustic musical instrument, and that cables can effect sound quality, and cable arrangement can have an impact on potential damage to a Seaboard, cables are an important consideration as part of a total working Seaboard system.
- Case:** Transportation is part of the use-profile of most keyboards and musical instruments more generally, so cases are an important component area to consider in relation to the lifecycle of a Seaboard.
- Stand:** Seaboards don't necessarily have bespoke stands. They need to sit on something - a table, a conventional keyboard stand, or a bespoke stand where applicable. Given the additional forms of pressure and left/right movement, Seaboards require more stability than keyboards.
- Audio output device (speaker/headphones):** Obviously speakers do not need to be built into Seaboards, but given that in a working context, Seaboards require amplification, they must be considered as part of a complete system.

3D rendered environment

A three-dimensional virtual environment visualized through computer-generated graphics, containing visual simulations of physical world elements such as perspective, shadow, and depth.

additive synthesis

A method of sound synthesis, constructing complex sounds by adding partials (sine waves) together.

ADSR

Attack, decay, sustain, and release are parameters which effect the sonic characteristic or harmonic content of a note. ADSR refers to the sequential sets of values of change in amplitude within a lifespan of a note. ADSR can be represented graphically. Attack is a note's initial increase or decrease in amplitude or the phase of a note from the time the key is initially pressed through its slope towards the initial decay value. Decay is the transitional phase between attack and sustain in which the amplitude of a note rises or falls to the sustain value. Sustain is the note's main sequence of sound from the point of applied continuous pressure to a key until the key is released. Release is the phase after the key is let off in which the sustain value tends towards zero. Hold is an additional parameter which allows one to maintain the sustain for a fixed length in time before decaying.

adaptive

A characteristic of SEA interfaces; the quality of neither completely rejecting nor accepting existing interfaces. Adaptive also refers to an approach towards SEA interface design; designed to fit a particular user or function-set independent of existing formal types; developing a product based on studies of the desired outputs and sociological facts of existing interface systems and the time required to learn the new skills relative to the efficiency or capabilities gained of the new interface.

aesthetic design

The multi-component issue termed aesthetic design covers the holistic sensory identity of the Seaboard as defined by its look, feel, and sound. This term includes the materials, the shapes, the colors, and the finishes that all define it as a physical object. It directly relates to all the physical component areas, (elastomer, chassis, sensor system, PCB/Ports, control/State Interface, stand, cables) and to the GUI in

any software that is necessary to the function of the Seaboard. Sound generation also directly relates to the aesthetic of the sound generation and design, and bridging this gap between the visual, tactile, and sonic aesthetics is a major challenge.

airbrushing

A tool and method for spraying liquid media such as ink, dye, and paint through the process of nebulization. This tool has been used for Seaboard silicone prototyping and production to create the multi-shade surface visual of the keywaves.

aftertouch

Aftertouch is the pressure applied to an already depressed piano key. It is also the MIDI protocol used for sending per note control and modulation data.

allen key

A wrench (available in a series of sizes) with a hexagonal cross-section used to secure bolts and screws. The Seaboard stand assembly requires an A4 allen key.

Analog-Digital Conversion

The method by which an analog value is converted into a digital representation for use in calculating peaks and producing MIDI data. For the Seaboard GRAND, raw FSR data measuring pressure resistance is translated into MIDI data.

anodization

An electrochemical process in which an oxide layer is chemically built on the surface of the metal. This oxide layer acts as an insulator and can be dyed in a wide variety of colors. Anodizing provides surface corrosion protection along with an excellent substrate for decorative finishes.

Archways

The ROLI prototyping facilities in Dalston, London located at 326-327 Stean Street E8 4ED. The Archways are the base-camp for ROLI's physical development teams: design for manufacture, mechanical engineering, design products, design interaction, and electrical engineering.

areas of development

The disciplines involved in the SEA interface and Seaboard product design and development: material science, silicone engineering, mechanical engineering, sensor development, firmware engineering, electrical engineering, software engineering, graphic design, sound design, audio engineering, interface design,

product design, industrial design, design for manufacture, and quality and assurance testing.

AU

Audio unit. Sets of application programming interface services provided by the operating system to generate, process, and receive streams of audio. It may be thought of as Apple's architectural equivalent to the other popular plug-in format, Steinberg's VST.

audio output device (speaker/headphones)

Speakers do not need to be built into Seaboards, but given that in a working context, Seaboards require amplification, they must be considered as part of a complete system.

auditory-visual correlations

A feeling of strong association between audio and visual stimuli. For example, when one hears volume or amplitude he/she may relate that to the physical size of a sound. Synaesthesia is an intensified state of auditory-visual correlations in which sensory stimulation of one sensory modality directly elicits an involuntary sensation in another sensory modality.

augmented reality (AR)

A real-time view of a physical environment augmented by computer generated audio-visual sensory input, which can be overlaid with one's naked-eye view of the physical world. AR is an environment to be contrasted with virtual reality -- a simulated real-world environment that replaces its real-world counterpart.

back panel

The anodized aluminium plate secured perpendicular to the top and bottom Seaboard GRAND chassis. The Seaboard GRAND LFE's each have a unique model number, a piano key note i.e. A0, engraved on the back panel.

balanced audio

A method of connecting audio equipment which is often used by professionals because it reduces the signal's likelihood of external noise. The Seaboard GRAND outputs balanced audio. In the system, there are two signals of opposite polarity rather than a single signal referenced to ground.

binary

A binary file is a computer file that is not a text file; it may contain any type of data, encoded in binary form for computer storage and processing purposes.

Bootloader

In computing, booting (also known as booting up) is the initial set of operations that a computer system performs after electrical power to the CPU is switched on or when the computer is reset.

Buildbot

Buildbot is a software development continuous integration tool which automates the compile/test cycle required to validate changes to the project code base.

build server

A computer that is dedicated to automatically compiling any programming project that is worked on by a team of people. It provides a way of guaranteeing the integrity of shared code as it changes, and of generating centralized, universally agreed version numbers.

build slave

A build server may instruct additional computers, called build slaves, to assist it. These either enable it to augment its computing power, or provide alternative environments for compiling the project (such as different operating systems).

cables

In most cases cables of some kind will be necessary to the function of the Seaboard. Given the particular ambition to create the feeling of an acoustic musical instrument, and that cables can effect sound quality, and cable arrangement can have an impact on potential damage to a Seaboard, cables are an important consideration as part of a total working Seaboard system.

case

Transportation is part of the use-profile of most keyboards and musical instruments more generally, so cases are an important component area to consider in relation to the lifecycle of a Seaboard.

chamfer

A bevelled edge connecting two surfaces. A chamfer is a form-factor used in the Seaboard design. The top and bottom end of the Seaboard keywave connects to the ribbon through a chamfer.

chassis

A hard, skeleton structure which supports an object's internal structure. The Seaboard GRAND has an aluminium structure referred to as the top and bottom

case or the top and bottom chassis respectively. The chassis is the main enclosure which holds the elastomer, sensor system, PCB/Ports and Control/State interface rigidly together and provides structural stability. It can sit on a stand where applicable.

clearance

The amount of 2D space an object occupies.

CLIVE

A machine developed by the ROLI Quality and Assurance team to test the Seaboard pressure sensitivity of integrated silicone sensor layers through variables such as the minimum activation. CLIVE is built on a CNC rig and measures points with a 3D rotational arm, programmable motor, and manual force gage.

CMF

Color, Material, Finish. An acronym used when talking about the aesthetic and textural details of a surface.

CNC

Computer Numerical Control. An end-to-end automated component design tool which cuts pre-programmed designs with a number of tools. It is composed of a chamber with a 3D arm programmable by computer-aided design (CAD) tools and computer-aided manufacturing (CAM) tools. ROLI has an in-house CNC for prototyping new designs.

code review

A software development term. Once a new feature or bug fix has been completed, it needs to be pushed into the codebase. Prior to it being formally merged with the existing code two other developers look over the code that is submitted to spot any errors with implementation, or formatting. Only once both are satisfied is the code made official on the repository.

continuous touch

GRAND, when a player presses a note with his/her finger, the silicone deforms, and then exerts after pressure back onto the player's finger.

continuous pressure

The degree of depression in a medium after the initial point of pressure.

Control / State Interface

Most working Seaboard systems will have some form of control/state interface. Depending on the exact system there a wide range of possible requirements for this – the two most minimal include a power on/off button of some kind, and power state indicator, like a LED light.

cover

Seaboard systems do not require covers but when left set up in a home environment covers are sometimes used to prevent dust.

code base

In software development, refers to the whole collection of source code used to build a particular application or component.

community

For ROLI, this refers to the joint group of people who contribute to ROLI, the internal team members, customers, etc. This group shares an interest in music.

compression moulding

A manufacturing process consisting of heating and adding pressure to a material in a mould cavity. Compression moulding can be used to produce curved solids. ROLI is considering using compression moulding to scale the Seaboard elastomer cast production.

continuous

Uninterrupted by time. A continuous action interface (CAI) is a human-computer Interactive system in which continuous user action generates continuous representation of objects. The Seaboard is a CAI. Users make spatial, gestural, and haptic movements to fluctuate sound dynamics. Continuous control is the ability to gather and map rich sets of data in a variety of ways, surpassing the limitations of discrete control. A continuous function is a function for which small changes in input produce small changes in output.

continuous pressure

Polyphonic pressure which is independent for each played note. Continuous pressure is activated at the moment the second a finger presses the key. The harder one presses down, the stronger the modulation.

continuous touch

The variation of finger pressure after the initial point of pressure is made and sustained on a key. This user function is a feature of the Seaboard embedded engine and soft surface.

craftsmanship

The skill of a particular method of making. The Seaboard design is a product of craftsmanship and mechanical and digital engineering.

customer experience

The full customer journey, from point of sale through product ownership.

cycle time

The time it takes to assemble and ship one product from in-house.

Cypher

A software synthesizer by Expansion from their DCAM Synth Squad instruments suite.

Dashboard

The Seaboard GRAND software user facing control software, which allows users to set custom expression curves, and access to preset and utility management through a custom, designed GUI.

DAW

Digital Audio Workstation. A tool for recording, editing, and playing back digital audio. This term refers to software which is used to record and produce music such as Cubase, ProTools, and Logic. The ROLI sound design team use DAWs.

debugging

A methodical process of finding and reducing the number of bugs, or defects, in a computer program or a piece of electronic hardware, thus making it behave as expected.

DFM

Design For Manufacture. This is the practice of optimizing a design so that it can be easily manufactured and assembled on a large scale for production.

dimensionality

Refers to the mapping capacity of a control. High dimensionality is optimal for optimizing musical expression in sound devices. To optimize dimensionality of real-time sound control and musical expression, a program should map medium dimensional user input to high dimensional sound output and increase the control parameters and the complexity of preset organization.

discrete

Individually separate and distinct. A discrete control interface (DCI) is a human-computer interactive system in which individual and separate user actions generate distinct representations of objects. Discrete control is an analogue, switch-based ability to simulate mechanical action. The Seaboard contains the functions of, but is not limited to a DCI.

design pattern

In software engineering, a general reusable solution to a commonly occurring problem within a given context in software design.

design practice

An individual's directed design objectives and conceptual and technical approach.

development build

Software that is released to internal testers. It usually contains extra diagnostics or special settings to enable faults to be traced more easily.

DSP

Digital Signal Processor; a device that is designed to efficiently process large amounts of digital data. This may be implementing filters, or in the case of the Seaboard GRAND, scanning the keyboard to determine the location of a player's fingers.

durometer

An instrument used to measure hardness of a material.

editable sound visualization

A screen-based tool used for generating, producing effects, and editing sound through the manual manipulation of a graphical user interface.

elasticity

The physical property of a material to reform to its original shape after deformation. The ability of the Seaboard to use distances as a way to amplify the perception of inputted pressure. The Seaboard contains a raised silicone surface which when pressed creates central notes. By stretching the elastic surface material, the note can be bent.

elastomer

A polymer with viscoelasticity. For the Seaboard, the elastomer constitutes the pliable body that makes up the top interaction surface, and translates forces onto (or into) the sensor system.

embedded system

A computer system with a set of designated functions, containing a processing core such as a microprocessor or a digital signal processor (DSP). The Seaboard GRAND contains firmware embedded in the top case.

EPP

Expanded Polypropylene. The Seaboard GRAND flight cases are made out of this material in the UK.

Equator

The name for the Seaboard GRAND data synthesis which accounts for one part of the ROLI Seaboard GRAND Software. The software and system that converts the Seaboard GRAND's control messages into sound that is outputted through the computer's speakers.

Equator Synthesis Engine (Embedded Equator)

The Seaboard GRAND's custom-built, embedded engine which allows it to work as a stand-alone synthesizer instrument. Equator Embedded is identical to an earlier development version, Equator, but can run fewer voices and does not have the user interface.

evolutionary approach to design

Creating and modifying the design as it is developed rather than pre-determining the design before the start of the development. This is an approach taken into account in the history of a given interface development, such as the piano keyboard, in considering how to innovate its key principles.

expression

One of three Seaboard mapping functions. These include the control of velocity, continuous touch, and pitch bending behavior. The users can modify expressions using the Dashboard software to change the touch sensitivity of their Seaboard.

extrusion

A manufacturing process in which a material is forced through a die of a specific cross-section. This process generates long components of a fixed-cross sectional geometry, and is a much more cost-effective method of producing such components than alternate processes such as CNC milling.

fat-presso

The width or fatness of a note. On the Seaboard, fat-presso is controlled by varying the finger pad's area of contact on the keys. Fat-presso was implemented on Seaboard 2 – LUTE series.

fillet

Interchangeable with radius, can also imply that it is not a circular arc, as seen on the top surface of the Seaboard.

firmware

In electronic systems and computing, firmware is the combination of persistent memory and program code and data stored in it. For the Seaboard, to process the analogue sensor data into digital data, and in some cases for many other operations including communication with the control/state interface, Seaboard requires firmware.

FSR

Force-sensing resistor. A conductive polymer whose resistance changes upon application of pressure. This is the sensor technology in the Seaboard GRAND and Seaboard POC and LUTE prototypes.

feedback

The effect of an action which in turn influences the following action within a loop of information. The Seaboard interaction experience is a synthesis of visual, tactile, and auditory feedback. The Seaboard provides visual feedback through a graphical user interface and the visuals of the silicone keys. The instrument provides tactile feedback through the deformation and reformation of the silicone surface. The instrument provides auditory feedback through the sound it transmits.

fluid interface

An interface which changes shape in reaction to human contact.

footprint

The amount of 2D space an object occupies.

glissando (or portamento)

A keyboard technique in which the player glides or slides from one pitch to another. On the Seaboard, glissando is produced by sliding the finger up and down the lower and upper ribbons.

glitch

Irregular and unwanted behavior of a technical tool. For example a glitch in the Seaboard could be a note which fluctuates between MIDI "Note On" and "Note Off" when the player applies the minimum activation pressure.

GUID

Global Unique Identifier; a string of numbers and letters that is unique to every Seaboard. This is stored in the STM32 (one of the processors inside the Seaboard) and ensures that any instrument can be uniquely identified.

GUI

Graphical User Interface. A virtual interface which represents interaction through images on a two-dimensional display screen. The Seaboard GRAND GUI graphs depict functions such as velocity mapping, pressure mapping, and pitch-bend mapping.

haptic

Of or related to the sense of touch. Haptic technology or haptic interface is a tactile feedback tool which responds to or amplifies the user's sense of touch by applying force, vibration, or motion to the user's body. Haptic feedback is the reactionary force applied to a user's body in response to an input. The Seaboard is a haptic technology, the player produces music by touching the silicone keys.

hexalobular

A screw head type used to prevent tampering in cases which require a high torque application. One must use a special torx head driver to screw these types of fasteners.

HCI

Human-computer interaction is the study and design of the physical and cognitive interaction between people and computers. HCI subfields include graphical user interface, tangible user interface, fluid interface, embedded and embodied interfaces, kinetic user interface, and organic user interface.

ICD

Interface Control Document. A ROLI development document that describes the messages and signals between two or more parts of a system. ICD is used between mechanical design & electronic design, electronic design & firmware, and firmware & software.

IDE

In software engineering, integrated development environment or interactive development environment is a software application that provides comprehensive facilities to computer programmers for software development.

injection moulding

A manufacturing method for producing component parts by injecting fluid material such as elastomers and thermoplastics into a mould where the fluid material hardens into shape. ROLI is considering compression moulding as an option for scaling Seaboard silicone cast production.

instrument

A device intended to perform a specific action to fulfil a given function. A musical instrument is a device which produces and adapts to musical sound. ROLI designs musical instruments for music performance and production.

interaction design

The practice of designing interactive products, services, environments, and systems.

interface

This term refers to the Sound Dial, used to identify the dial/button assembly on the Seaboard.

interpolation

A technical method use to turn raw sensor data into precise interaction data. The Seaboard firmware interpolates.

intuitive design

The creation of systems and objects according to the tendencies and properties of human inclination.

jitter

Undesired randomness in time of a system. For real-time sound control, temporal jitter reduces sonic quality by inhibiting consistent information transmission rates. Minimizing jitter is part of the Seaboard UX spec.

JTAG

Joint Test Action Group. A protocol agreed on by many microchip manufacturers that enables them to be tested, programmed, and debugged in a commonly agreed upon way. A JTAG programmer is a piece of hardware that connects a

computer with such microchips. At ROLI, this is a tool used to program and debug firmware running on our hardware (in our case, used for the STM32 and DSP)

JUCE

Jules' Utility Class Extensions. A series of programming libraries that the Seaboard GRAND User Dial, amongst other features, uses. JUCE enables MIDI, audio, and user interface design to be treated in the same way irrespective of whether a programmer is writing for Windows, Mac OS, Linux, or a mobile device.

keywave(s)

The undulating curved surface contour of the Seaboard key. Number and size of keywaves per Seaboard is a multi-component issue. It is an important design issue for any particular Seaboard product. It is directly relates to the elastomer, chassis, sensor system, PCB/Ports. It also indirectly relates to control/state interface, stand, firmware, software, sound generation, as well indirectly relating to other multi-component issues including visual design, cost, assembly, transportation, latency, and use.

kinaesthetic feedback

The awareness of one's body parts, position, and movement based on information from the nerves in joints and muscles, sometimes referred to as proprioception.

KUI

Kinetic User Interface. An interface, which allows humans and computers to interact through objects.

Lambde Ltd.

The ROLI company name before May 2013, whereupon it became ROLI Ltd.

laddering

The rippling or bunching effect of a material when an object is moved across it. The Seaboard aims to eliminate laddering of fingers across the keys, particularly for the glissando effect on the ribbon.

latency

The measure of a system's time delay. For the Seaboard real-time sound control, latency obstructs the system's ability to translate human touch to sound. The objective is to reduce latency in order to map event parameters to output data immediately.

lathe

A machine tool with a 3D rotating arm used to create objects. ROLI has an in-house lathe for prototyping.

lead time

The time it takes to make something.

LFO

Low-frequency oscillator. An element in sound synthesis that can be used to add vibrato, tremolo, or similar wobbly effects. This is an element of Equator.

Linux

Linus Torvald's Unix. A Unix-like operating system kernel used by a variety of operating systems usually in the form of Linux distributions. The operating system upon which the Seaboard's internal synthesizer runs.

Logic

Apple Mac's Digital Audio Workstation (DAW). It is a self-contained software music production studio, which allows recording and editing audio plus MIDI data.

LUTE Seaboard

Lead User Test Enabled Seaboard. It is a 61-note Seaboard prototype previously used for user trials and endorsement. Each LUTE Seaboard is identified by a character (C, D, D#, E) and a number (1 to 5).

mapping

The association of one set of elements with another, often the domain with the range. Data mapping is transferring information between distinct data models. The Seaboard GRAND LFE, STAGE, and STUDIO is a MIDI controller which maps FSR 3D input into MIDI data.

MDC

Multi-dimensional controller. A protocol, which allows event information to be mapped and transferred digitally in multiple dimensions into multiple inputs. For example, location can be mapped to pitch. Different MDC attributes are commonly used as inputs in a modulation matrix. The Seaboard employs a revolutionary MDC, which maps physical input from a person's gestures to a software output for a computer to produce sound.

merge conflict

A software development term. When each developer's code needs to be merged together for the another build of the software, it is possible for the same line to

have been modified in two different ways, causing a conflict. These are flagged prior to a merge request, and requires developer intervention to resolve before their request may be submitted.

merge request

A software development term. Once a developer has completed a task, feature, or bug fix, he or she submits the code to the repository as a merge request. This request goes through code review, and once approved, it merged into the codebase for the next build.

MIDI

Musical Instrument Digital Interface is a music industry standard communication protocol used to transfer abstract musical information i.e. note, number, and pitchbend values between digital instruments, computers, applications, and other related devices.

MIDI Controller

A physical interface, which uses physical sensors to capture input from a user to control a synthesizer. The Seaboard is a keyboard MIDI controller.

milling

A manufacturing process in which rotary cutters are computer-programmed to remove material, leaving the desired final shape intact. This process can produce very complicated shapes with high precision, but is also quite costly, mainly due to the long setup and production times required to manufacture each component.

Minimum Activation Point (MAP)

The point of applied pressure at which the Seaboard registers a note on. (Generally, the lower the MAP, better the Seaboard performs. If a Seaboard has high or inconsistent MAPs across the board, then it will be more difficult to play.) LFE MAP is about 2 newton/key (200 grams). Disambiguated by referring to P-MAP or V-MAP.

Model Number (Seaboard GRAND LFE)

The model number refers to the keynote inscribed on the back panel of the Seaboard GRAND LFE back panels.

Modulation Matrix

A feature of the ROLI Equator Synthesis Engine. It allows the user to define changes to the synth engine parameters i.e. X-location, touch-pressure, with respect to a set of inputs and then modulates them to alter their target variables

i.e. frequency, volume. The modulation 'animates' the sound in various ways to make it dynamic and expressive for music in response to player's expressive gestures. (i.e. the amount of aftertouch affects the volume of Oscillator 1).

MPE

Multi-point envelope. ROLI Seaboard envelopes are more versatile than traditional ADSR envelopes because they allow periodic retriggering and multiple attack and release portions.

multiplexing

A method used to 'combine' several analog signals into one single one. In the case of the Seaboard, several FSRs (Force Sensitive Resistors) are multiplexed so that many can be read by a single analog to digital converter.

MIDI

Musical instrument digital interface. A music industry command standard that enables a wide variety of digital musical instruments, computers and other related devices to connect and communicate with each other. MIDI was developed during the 1970s as a way of integrating different polyphonic synthesizer machines, which were initially incompatible. The term may refer to the commands themselves, software, hardware device, computer, digital interface, and/or connectors and type of connection. The MIDI protocol poses a number of challenges to sound designers, including encoding pitch-bend and volume as global parameters, which limits a player's expressivity. The Seaboard can function as a MIDI controller.

noise

Irregular fluctuations in data or electrical signals that does not obscure the primary trend or behaviour. The design team rarely deals with audio noise, which is in our case is a downstream result of electrical noise.

optimization

The process of altering a system to maximize the efficiency of certain parameters without creating additional constraints to the system.

OSC

Open Sound Control. A content format for communicating between computers, sound synthesizers, and other multimedia devices.

OUI

Organic User Interface. A non-planar, touch sensitive surface which may actively or

passively change shape via analogue physical inputs. One OUI performance specification is that the form of the interface follows the flow of its function. The Seaboard is an OUI.

P-MAP

Pressure minimum activation point. A term in Seaboard development synonymous with MAP.

PCB

Printed Circuit Board. The Seaboard embedded engine hardware component which may refer either to a bare circuit board, or collectively, one that is populated with components. In the Seaboard, the PCB accepts the data from the sensor system, and, depending on the system configurations, either simply turns the analogue data into digital data and passes the data onto a computer, or further processing of the data and sound generation can take place on board.

ports

Most possible Seaboards will have ports of some kinds, connecting the PCB to a power source, audio output device, or external computer.

PPP

An acronym for Pre Production Prototype, the last product prototype before production.

piano keyboard-related interface

An interface, which borrows functions and forms from the piano keyboard interface. Traditional piano keyboard-related interfaces are limited by the keyboard paradigm: on a piano, the note starts when the movement finishes. The Seaboard is a piano-keyboard related interface but it challenges the conventional keyboard paradigm. On the Seaboard, the note starts when the finger exerts the minimum activation pressure. From the initial point of touch, the user can modulate dynamics through aftertouch and continuous touch.

piano mode

A Seaboard performance mode. Every touch is quantized to the nearest note, in order to keep Seaboard in tune. Pitch bend is turned off, so a glissando generates many separate notes as it would on a piano. Piano mode can be activated either via Dashboard or by holding down a specially configured pedal.

piezo-resistive

The change of electrical resistance corresponding to applied force.

pitch control

The degree to which a user can change the pitch of a musical note on an audio device.

pitch-bending

A smooth change in pitch from one tone to another. On the Seaboard, one changes the pitch by pressing the vertical axis of symmetry of a key and then rotating the pressure from left to right of the axis continually. The Seaboard allows for continuous and discrete polyphonic pitch bending of up to ten notes simultaneously by modulating the fingers across the x-axis and ribbon.

pitch-bend quantization

The digital manipulation of pitch bend data from the Seaboard, controlled using Dashboard, so that it can change smoothly (linear), be quantized to the nearest semitone (stepped), or somewhere in-between.

pitch rounding

The snapping of pitch to the nearest semitone when a note is played (as opposed to its subsequent behavior).

planar interface

A physical interface composed of a singular, flat surface. A multi-planar interface is composed of multiple flat surfaces.

plasticity

The physical property of a material to be reformulated as desired.

polymer

A macromolecule composed of monomers. Polymers come in both natural and synthetic varieties. Examples include biological polymers such as DNA and proteins and plastics such as polystyrene (Styrofoam). Silicone, the material used for the Seaboard GRAND surface, is a polymer.

Polyphony

Consisting of two or more voices played simultaneously or two or more lines of independent melody. For example, 1 note polyphony means that a sound is effectively monophonic and only one note can be played at a time. 10 note polyphony means that the sound can produce ten simultaneous voices. 2 polyphonic detection is the capacity of a device to identify multiple, discrete notes simultaneously. 3 polyphonic expression is the playing of multiple notes

simultaneously. 4 polyphonic pitch-bending is the ability to bend the pitch of individual notes independently. 5 polyphonic aftertouch is the respective sensation of pressure transmitted for each key. 6 the Seaboard is capable of polyphonic expression, polyphonic pitch-bending, and polyphonic aftertouch.

primary output vs. secondary output

Refers to the Seaboard interaction. The primary output is the note event; the secondary output is the change in volume or pitch of that note.

production build

Software that is intended for release to the general public. It is usually compiled with special settings to be as fast and compact as possible, and is free of all but the most basic diagnostics.

pushing and pulling

Software development terms. Pushing is the act of moving code from your local machine to the repository (which is located on the internet). Pulling is the act of pulling the latest code from the repository onto your local machine.

QA

Quality assurance. QA is a wide field of engineering that is concerned with making sure that products and services meet an expected level of quality.

QC

Quality control. The testing of any product, process, or service in a systematically defined way. The ROLI QA team is designing a QC test to be carried out during assembly.

QLIVE

Quick, Look Impressive! Visitor Encroaching. A ROLI development test run by CLIVE to gather Minimum Pressure Activation Points from the different silicone recipe, sensor aligning, and software algorithm combinations.

radius

A rounded corner, either internal or external, on the edge or profile of a part.

rational design

The strategy of creating an object or system with a certain functionality based on the prediction of how the object or system's structure will effect its behaviour through a physical model.

ribbon

The continuous, horizontal area perpendicular to the keys of the Seaboard GRAND. There are two ribbons, one at the top of the keys and one at the bottom. A player can slide his/her finger back and forth across the ribbon or down the keys to the ribbon to create a glissando or waver a finger on it to bend pitch.

real-time timbre synthesis engine

An engine which recognizes, models, and predicts the timbre of acoustic instruments in real-time based on perceptual features extracted from an audio stream. The Seaboard is a real-time timbre synthesis engine.

RedBoot

A Linux bootloader. The bootloader runs basic checks of the embedded Linux software before the processor runs it in order to detect corruption. It also contains powerful facilities for upgrading, debugging, and manipulating the embedded software (including Linux) that cannot be provided by Linux itself.

redline

A minor change to a technical drawing, usually at the request of the manufacturer of a part. These were traditionally done with red pen, hence the name, and can be tracked to measure design oversights or improvements to DFM.

reflective morphology

The shaping factors and tendencies, which reflect the potential of a particular set of characteristics.

repo

Repository. A software development term which refers to the entity used to store, backup, and maintain versions of all to software written at ROLI.

RTAS

Real Time Audio Suite. A format of audio plug-in developed by Digidesign, (now AVID Technology), for their Pro Tools LE, and Pro Tools M-Powered systems.

SEA Interface

Sensory, Elastic, Adaptive Interface. A new patent-pending interface system technology developed by ROLI. It is based on touch-applied pressure diffusing through an elastomer and being registered by an array of pressure sensors, with software using interpolation to infer the precise position and nature of the touch interaction through an embedded microprocessor. SEA Interfaces provide information-rich variables and simultaneously allow for multiple kinds of inputs,

including those which denote discrete and continuous commands, spatial location, and pressure-level.

SEA Labs

ROLI's former trading name.

Seaboard

The first application of the SEA Interface. The Seaboard is a new musical instrument and sound controller which combines the qualities of acoustic instruments with digital music allowing the player to continuously and discretely control pitch, volume, and timbre of notes through haptic interaction with an elastic keyboard surface.

Seaboard 3

The earliest working prototype of a complete Seaboard, from 2009. It's the spongy, one-of-a-kind Seaboard with white keys and an integrated stand.

Seaboard Core Versions [DEVELOPMENT]

This is a reference code (for example 1.0.0.123) for developers which links to a series of subcodes (examples in parenthesis) in the ROLI build records online (builds.roli.com) for the following digital components: DSP (0.1.9) , Embedded Equator (1.0.1.96_dev), Kernel-Image (b4d1be0), Kernel-Rootfs (b4d1be0), Manager (b4d1be0), STM32 (0.1.3), STM32boot (0.0.2), and Update (b4d1be0). This code is used to keep track of build updates.

Seaboard Core Versions [PRODUCTION]

This is a reference code for customers displayed in the Seaboard GRAND Software home window and links to the following subcodes (examples in parenthesis) for developers the following digital components: DSP (0.1.4) , Embedded Equator (1.0.1.18), Kernel-Image (b4d1be0), Kernel-Rootfs (b4d1be0), Manager (b4d1be0), STM32 (0.1.2), STM32boot (0.1.2), and Update (b4d1be0). This code should be used to identify Seaboards for the purpose of customer service issue tracking.

Seaboard PPP A

The first prototype of the Proof of Product Concept: Seaboard PPP prototypes. The Pre-production prototype used new PCBs and FSR sensors. The main difference between PPP and retail units is that PPP units lack a SD memory card, so cannot play back samples.

Seaboard PPP B

The second prototype of the Proof of Product Concept: Seaboard PPP prototypes.

This model was demonstrated at the SXSW launch in March 2013.

Seaboard GRAND LFE

Seaboard GRAND Limited First Edition 88-note market product.

Seaboard GRAND Software

The software for OSX (and ultimately Windows) that ships with the Seaboard, comprising Dashboard and eventually Equator.

Seaboard GRAND STAGE

The Seaboard GRAND 61-key model designed for a studio environment and “to go on the road.”

Seaboard GRAND STUDIO

The Seaboard GRAND 37-key model designed to be portable, versatile, affordable enough to be purchased for a home studio.

Seaboard Peripherals

Parts on the back panel: power supply, USB ports, audio outputs, pedal inputs and Sound Dial.

sensor system

The Seaboard sensor system detects the forces applied onto it via the elastomer, and transmits this analogue data to the PCB.

Serial Number

A unique ID given to each Seaboard GRAND. This number is viewable in the Seaboard GRAND Software and serves as the first point of identification for the internal assembly line and issue tracking and external unit identification and customer service enquiries.

silicone

A synthetic polymer used for the Seaboard GRAND surface. The ROLI silicone mixture components are: base, catalyst, deadener, pigment (BP- black Pigment, WP- white Pigment), toluene, acetone. The layers in procedural order (top down from Seaboard player’s POV) are: 1st Layer Spray, 2nd Layer Spray, Top (layer), Ribbon (layer), Filler (Layer), Bulk (Layer).

skeletal

Refers to the feeling of unevenness in hardness in the Seaboard silicone body. The Seaboard aims to reduce skeletal feel and achieve a target balance of

hardness and thickness of silicone, through the casting mixture ratios and procedure.

slur

A symbol of musical notation and performance technique in which consecutive notes of different pitches are to be played without separation. This is a technique playable with the Seaboard but not as intuitively achieved with most other keyboard instruments. A slur is most commonly used with wind or stringed instruments.

SMT

Surface-Mount Technology; a type of electrical/electronic component package where the device is mounted directly to the surface of a PCB rather than having legs which extend through the board. This technology allows for denser circuitry, and is used throughout the Seaboard.

software

Seaboard, when connected to a computer, need some form of software to control various settings and parameters.

SOM

System-on-Module. A complete computer system including all support circuitry built in to a single circuit board. ROLI will be using a Cortex-A8 SOM as the main processor in the Seaboard GRAND to allow for future upgradeability and reduced design time.

Sound Dial

Seaboard component. A custom-built aluminum, circular hardware component positioned at the top center of the chassis. It is used to manually select Seaboard sounds, control between presets, as well as shift octaves. This is referred to as the User Dial or the hardware dial in the Seaboard user manual.

sound generation

Once note data, in one format or another has been created, Seaboard, need to utilise some form of sound generation, e.g. sample playback, a synthesis engine, which could run on an embedded system or a computer or hardware synth.

SoundHive

The sound design and demo room at the ROLI Head Quarters. It is the primary workspace for the audio engineering and sound design teams. The room has custom designed acoustics and a performance stage. The interior walls of the

room are covered in hand-cut wooden hexes with varying thicknesses and top planar angles to deflect sound for live Seaboard and other instrument performance.

sound morphing

The process of morphing between two presets.

stand

Seaboards don't necessarily have bespoke stands. They need to sit on something - a table, a conventional keyboard stand, or a bespoke stand where applicable. Given the additional forms of pressure and left/right movement, Seaboards require more stability than keyboards.

STM32

SGS-Thomson Microelectronics 32-bit is a 32-bit ARM microcontroller made by ST Microelectronics which oversees internal communication inside the Seaboard, and controls the LED ring as well as monitoring the pedals and User Dial.

STM32 Common Library

A set of firmware modules in C that ROLI has developed and declared as Gitsubmodule to simplify common programming tasks. The STM32 is used to fix bugs and make improvements in firmware development projects by simply changing a single file in one repository.

STRiFiBu

Refers to the Seaboard silicone process in the order of layers sprayed and casted: Sprayed XTX + Top Silskin 10+ Ribbon Silskin 10+ Filler Silskin 10 + Bulk Silskin 10.

subtractive synthesis

A method of sound synthesis, which uses filters to attenuate or limit the partials (simple sine wave components of a complex sound) of an audio signal. The most common audio signals used in subtractive synthesis are simple sound wave oscillators i.e. sinusoid wave, square wave, triangle wave.

Supervisor

The part of Embedded Equator that deals with audio and MIDI traffic.

supple

The property of a material to readily change or adapt to the application of physical forces. A supple body can be stretched from its original form and then return to it. The suppleness of the Seaboard enhances its tactile feedback, and allows for a

diffusion of forces through a relatively soft body which in turn creates a non-planar pressure sensitive surface and enhances the size of the pressure signature on the bottom of the body. This action increases sensor efficiency.

tactile

Of the sense of touch. Tactile feedback is the sensation of the force exerted in reaction to the input of the user's touch. A tactile interface is a physical interface which is activated by touch.

taxel

Tactile cell: an individual reading in a series of finger pressures.

tickets

A software development term sometimes referred to as "issues". This is a single, quantifiable task that a member of the digital team (typically, but not always) is to perform. Tickets are grouped into milestones which correspond to software releases. Tickets can be made internally to specify new features or as a result of user feedback, or testing, to detail bugs that have been found.

temporal accuracy

Refers to the temporal accuracy with which the performance of a task can be started at a predetermined time. This term is used in the context of real-time music gestural performance.

temporal precision

The smallest time interval over which humans have control. Temporal precision is usually a smaller numeric value compared to temporal accuracy. Spatial audio control data requires high temporal precision to avoid artefacts in multi-loudspeaker arrays. This term is used in the context of real-time music gestural performance.

timbre

The intangible quality or audio characteristics of a sound. Timbre is sometimes described as the tone or color of a sound. A timbre distinguishes sounds with similar parameters from each other. Different instruments produce different timbres.

Tomato

Control software for the LUTE and Grand A and B Seaboards. Running on a Mac, it turns the Seaboard's raw sensor data into MIDI events. The ROLI retail products integrate this functionality into Seaboard, so they do not require Tomato.

top case

The top chassis of the Seaboard GRAND made of anodized aluminium.

torx

A star shaped screw head. In Seaboard assembly, used to secure the exterior screws on the bottom of the chassis.

Touch 2.0

An internal ROLI term used to describe the SEA interface, meaning the collection of all the touch-based interface technologies that the company develops. Touch 3.0 will refer to the next generation of touch-based technology.

TPE

Thermoplastic elastomers. This material is often used for manufacturing such as injection moulding. This is a possible option for the new Seaboard surfaces.

transfer function

A function, which maps variables between varying contexts. For example, a pressure value between 0 and 1024 can be mapped to the velocity range of the MIDI protocol 0-127.

tribometer

An instrument used to measure the coefficient of friction.

TUI

Tangible user interface. A physical interface in which a user interacts with digital information through a physical environment. Tangible media is tactile or touchable media.

U-Boot

A bootloader. An alternative to RedBoot that exists for the same reasons, but provides a slightly different class of functionality.

Unit test

In computer programming, a method by which individual units of source code, sets of one or more computer program modules together with associated control data, usage procedures, and operating procedures are tested to determine if they are fit for use.

USB Type A

A socket, often referred to as a 'USB Host' socket, which allows devices such as USB memory sticks, and USB-MIDI adapters to be plugged in. The rear of the Seaboard GRAND has a USB Type A socket.

USB Type B

The Seaboard GRAND has a USB Type B connector to allow connection to a host computer.

user

A human or software agent who takes part in an interaction. 2 user-centered design is a process of conception and development focused on the specific needs of a target user. 3 user-generated design incorporates the input from its target user in its construction. 3 user-oriented design is developed for a specific user. 4 the Seaboard is created through user-interface design, the way in which living, organic beings interact with, intersect with, and ultimately integrate embodied digital technologies into the self. 5 The primary Seaboard users are: artists or end users (players, performers, producers), sound software developers, and hardware manufacturers.

R button

The physical push-button switch in the center of the Sound Dial. The button is used to put the Seaboard GRAND into Standby (low-power) mode and wake it up again (long press), to change presets (short press) and to enter 'octave shift' mode (medium press).

value engineering

A method to improve the value of a product through examination.

velocity

For the Seaboard, velocity refers to the initial point of pressure of the finger on the key's surface.

velostat

The polymeric foil with carbon additive which features piezo-resistive effect.

vibrato

A musical effect, a pulsing change in pitch or rapid reiteration of a tone. The Seaboard player can produce vibrato by modulating the finger between notes across the vertical axis of symmetry of each key.

virtual reality

A simulated real-world environment that replaces its real-world counterpart. An environment in contrast with augmented reality.

visualization

A communication technique, producing images or animations to illustrate a message.

volume

The sonic intensity of a note. A note's volume is a function of its amplitude. For the Seaboard, volume is tangibly controlled by finger pressure.

V-MAP

Velocity minimum activation point. V-MAP as a concept concerns the modulation of key pressure over time that causes it to register as a touch. V-MAP is not measured directly, but is a qualitative phenomenon. Seaboard firmware uses different rules to process fast-rise and slow-rise touches to improve V-MAP.

VST

Virtual Studio Technology. Virtual Studio Technology (VST) is an interface developed by Steinberg (the company that makes Cubase) for integrating software audio synthesizer and effect plugins with audio editors and hard-disk recording systems.

waterfall

Waterfall model is a sequential design process, often used in software development processes, in which progress is seen as flowing steadily downwards (like a waterfall) through the phases of Conception, Initiation, Analysis, Design, Construction, Testing, Production/Implementation, and Maintenance.

white glove customer support

First class support for our customers.

wiring table

A table showing every internal electrical interconnection within a product. This data is used to produce the physical wiring assemblies that connect the various PCB assemblies in the Seaboard.

work flow

The sequence of actions unique to each user or group of users. The Seaboard capabilities are designed to be flexible so that end users (artists, performers,

producers) may integrate the instrument with their current workflow.

XTS

Refers to the Silskin 10, the newest 2014 production batch silicone supply.

XYZ

Refers to the dimensions of pressure-sensor interaction on the SEA Interface: X to horizontal or left-right input, Y to vertical or away-towards input, Z to upward-downward. Currently the Seaboard processes X and Z input, but not Y.

Bibliography

- Andersen, T.H., Zurich, E.T.H. & Fjeld, M., 2006. Feel the Beat : Direct Manipulation of Sound during Playback. *TABLETOP*, (06 Proceedings of the First IEEE International Workshop on Horizontal Interactive Human-Computer Systems), pp.123–126.
- Aristotle, and Terence Irwin. *Nicomachean Ethics*. Indianapolis, IN: Hackett Pub., 1985.
- Arts, M. et al., 2011. The Electromagnetically Sustained Rhodes Piano. In *NIME*. Oslo, Norway, pp. 14-17.
- Atkinson, P. "The (in)difference Engine. Explaining the Disappearance of Diversity in the Design of the Personal Computer." *Journal of Design History* 13, no. 1 (12, 2000): 59-72 .doi:10.1093/jdh/13.1.59.
- Austin, L., Kahn, Douglas, and Nilendra Gurusinghe. 2001 *Source: Music of the Avant-gard*. Berkeley: University of California Press.
- Balaban, Mira, and Michael Elhadad. "On the Need for Visual Formalisms in Music Processing." *Leonardo* 32, no. 2 (12 1999): 127-34. doi:10.1162/002409499553109.
- Barron, James. *Piano: The Making of a Steinway Concert Grand*. New York: Times Books, 2006.
- Bellotti, Victoria, Maribeth Back, W. Keith Edwards, Rebecca E. Grinter, Austin Henderson, and Cristina Lopes. "Making sense of sensing systems: five questions for designers and researchers." In *Proceedings of the SIGCHI conference on Human factors in computing systems*, pp. 415-422. ACM, 2002.
- Benjamin, Walter, Hannah Arendt, and Harry Zohn. *Illuminations*. New York: Harcourt, Brace & World, 1968.
- Berman, Boris. *Notes from the Pianist's Bench*. New Haven: Yale University Press, 2000.
- Berthaut, F., Desainte-Catherine, M. & Hachet, M., 2011. Interacting with 3D Reactive Widgets for Musical Performance. *Journal of New Music Research*, 40(3), pp.253-263.

- Blaine, Tina, and Sidney Fels. "Contexts of collaborative musical experiences."
In *Proceedings of the 2003 conference on New interfaces for musical expression*,
pp. 129-134. National University of Singapore, 2003.
- Born, Georgina. *Rationalizing Culture: IRCAM, Boulez, and the Institutionalization of the Musical Avant-garde*. Berkeley: University of California Press, 1995.
- Born, Georgina, and David Hesmondhalgh. *Western Music and Its Others: Difference, Representation, and Appropriation in Music*. Berkeley: University of California Press, 2000.
- Bott, Jared N., James G. Crowley, and Joseph J. LaViola Jr. "Exploring 3D gestural interfaces for music creation in video games." In *Proceedings of the 4th international Conference on Foundations of Digital Games*, pp. 18-25. ACM, 2009.
- Bradley, Arthur. *A Language of Emotion: What Music Does and How It Works*. Bloomington, IN: AuthorHouse, 2009.
- Burdea, Grigore, and Philippe Coiffet. *Virtual Reality Technology*. New York: Wiley, 1994.
- Byrne, David. *How Music Works*. San Francisco: McSweeney's, 2012. Print.
- Cance, Caroline, Hugues Genevois, and Danièle Dubois. "What is instrumentality in new digital musical devices? A contribution from cognitive linguistics and psychology." *arXiv preprint arXiv:0911.1288* (2009).
- Casagrande, N., Eck, D. & Kegl, B., 2005. GEOMETRY IN SOUND: A SPEECH/MUSIC AUDIO CLASSIFIER INSPIRED BY AN IMAGE CLASSIFIER. In *Proceedings of the International Computer Music Conference (ICMC)*. pp. 207–210.
- Castellano, Ginevra, Marcello Mortillaro, Antonio Camurri, Gualtiero Volpe, and Klaus Scherer. "Automated analysis of body movement in emotionally expressive piano performances." (2008): 103-119.
- Cheng, I., et al. 3D online multimedia & games : processing, transmission and visualization. Singapore; Hackensack, N.J. : World Scientific, c2009.
- Churchland, Paul M. *Plato's Camera: How the Physical Brain Captures a Landscape of Abstract Universals*. Cambridge, MA: MIT Press, 2012.

- Collicutt, Mike, Carmine Casciato, and Marcelo M. Wanderley. "From real to virtual: A comparison of input devices for percussion tasks." In *Proceedings of NIME*, pp. 46. 2009.
- Conference, I. & Display, A., 2006. CONVERTING IMAGES TO MUSIC USING THEIR COLOR Department of Informatics Aristotle University of Thessaloniki. , pp.198–205.
- Cook, Nicholas. *The Cambridge Companion to Recorded Music*. Cambridge: Cambridge University Press, 2009.
- Cook, Perry R. *Music, Cognition, and Computerized Sound: An Introduction to Psychoacoustics*. Cambridge, MA: MIT Press, 1999.
- Cook, Perry R. "Re-Designing Principles for Computer Music Controllers: a Case Study of SqueezeVox Maggie." In the *Proceedings of New Interfaces for Musical Expression*. 2009.
- Cope, David. *Computer Models of Musical Creativity*. Cambridge, MA: MIT Press, 2005.
- Corbett, Richard, Kees Van Den Doel, John E. Lloyd, and Wolfgang Heidrich. "TimbreFields: 3D Interactive Sound Models for Real-Time Audio." *Presence: Teleoperators and Virtual Environments* 16, no. 6 (12 2007): 643-54. doi:10.1162/pres.16.6.643.
- Cox, Christoph, and Daniel Warner. *Audio Culture: Readings in Modern Music*. New York: Continuum, 2004.
- Dean, Matt. *The Drum: A History*. Lanham, MD: Scarecrow Press, 2012.
- Desainte-catherine, M. & Hachet, M., 2010. COMBINING AUDIOVISUAL MAPPINGS FOR 3D MUSICAL INTERACTION.
- Dobrian, Christopher, and Daniel Koppelman. "The'E'in NIME: musical expression with new computer interfaces." In *Proceedings of the 2006 conference on New interfaces for musical expression*, pp. 277-282. IRCAM—Centre Pompidou, 2006.
- Dolge, Alfred. *Pianos and Their Makers: A Comprehensive History of the Development of the Piano from the Monochord to the Concert Grand Player Piano*. New York: Dover Publications, 1972.

- Dolhansky, Brian, Andrew McPherson, and Youngmoo E. Kim. "Designing an expressive virtual percussion instrument." In *Proceedings of the 8th Sound and Music Computing Conference, Padova, Italy*, pp. 6-9. 2011.
- Eaton, J., and Robert Moog. 2005. Multiple-touch-sensitive keyboard. In *Proceedings of the 2005 conference on New interfaces for musical expression (NIME '05)*. National University of Singapore, Singapore, Singapore, 258-259.
- Farnell, Andy. *Designing Sound*. Cambridge, MA: MIT Press, 2010.
- Fingelkurts, Andrew A., and Alexander A. Fingelkurts. "Timing in Cognition and EEG Brain Dynamics: Discreteness versus Continuity." *Cognitive Processing* 7, no. 3 (12 2006): 135-62. doi:10.1007/s10339-006-0035-0.
- Fitz, Kelly, Lippold Haken, Susanne Lefvert, Corbin Champion, and Mike O'donnell. "Cell Utes and Flutter-Tongued Cats: Sound Morphing Using Loris and the Reassigned Bandwidth Enhanced Model." *Computer Music Journal* 27, no. 3 (12 2003): 44-65. doi:10.1162/014892603322482529.
- Fitzmaurice, G.; Ishii, H.; Buxton, W.: Bricks: Laying the Foundations for Graspable User Interfaces. In: *Proceedings of the CHI'95*. New York, USA, ACM, 1995; pp.442-449.
- Follmer, S. et al., 2011. deForm. In *Proceedings of the 24th annual ACM symposium on User interface software and technology - UIST '11*. New York, New York, USA: ACM Press, p.527.
- Franinovic, Karmen and Serafin, Stefania eds., 2013. *Sonic Interaction Design*. Cambridge: MIT Press.
- Freyer, Conny, Sebastien Noel, and Eva Rucki. *Digital by Design: Crafting Technology for Products and Environments*. London: Thames & Hudson, 2008.
- Freed, A. and Aviziens R. A New Music Keyboard featuring Continuous Key-position Sensing and High-speed Communication Options, In *Proceedings, International Computer Music Conference, Berlin, Germany, 2000*.
- Garvey, Gregory P. "The Split-Brain Human Computer User Interface." *Leonardo* 35, no. 3 (12 2002): 319-25. doi:10.1162/002409402760105352.
- Gelineck, Steven, and Stefania Serafin. "A quantitative evaluation of the differences between knobs and sliders." In *New Interfaces for Musical Expression*. 2009.

- Ghamsari, Mahtab, Amandine Pras, and Marcelo Wanderley. "Combining musical tasks and improvisation in evaluating novel Digital Musical Instruments." In *Proceedings of the 10th International Symposium on Computer Music Multidisciplinary Research*, 2013.
- Giannakis, K. & Smith, M., 2000. Auditory-Visual Associations for Music Compositional Processes: A Survey. In *Proceedings of the International Computer Music Conference (ICMC)*. Berlin.
- Giannakis, K. & Smith, M., 2001. Imaging Soundscapes : Identifying Cognitive Associations between Auditory and Visual Dimensions. In R. Godoy and H. Jorgensen, ed. *Musical Imagery*. New York: Taylor & Francis, pp. 51–69.
- Goebel, W., Bresin, R. and Galembo, A. 2004. Once Again: The Perception of Piano Touch and Tone. Can Touch Audibly Change Piano Sound Independently of Intensity? *Proceedings of the International Symposium on Musical Acoustics*
- Goebel, Werner, and Caroline Palmer. "Tactile Feedback and Timing Accuracy in Piano Performance." *Experimental Brain Research* 186, no. 3 (12 2008): 471-79. doi:10.1007/s00221-007-1252-1.
- Greenberg, S.; Fitchett. C.: Phidgets: Easy Development of Physical Interfaces through Physical Widgets, *Proceedings of UIST'01*, ACM Press, 2001.
- Gritten, Anthony, and Elaine King. *New Perspectives on Music and Gesture*. Farnham: Ashgate Pub., 2011.
- Gurevich, Michael, Paul Stapleton, and Adnan Marquez-Borbon. "Style and constraint in electronic musical instruments." In *Proc. NIME*, vol. 10. 2010.
- Hafner, Katie. *A Romance on Three Legs: Glenn Gould's Obsessive Quest for the Perfect Piano*. New York: Bloomsburg, 2008.
- Haken, Lippold, Ed Tellman, and Patrick Wolfe. "An Indiscrete Music Keyboard." *Computer Music Journal* 22, no. 1 (12 1998): 30. doi:10.2307/3681043.
- Handel, Stephen. *Listening: An Introduction to the Perception of Auditory Events*. Cambridge, MA:MIT Press, 1989.
- Hanington, Bruce. "Methods in the Making: A Perspective on the State of Human Research

in Design." *Design Issues* 19, no. 4 (12 2003): 9-18.
doi:10.1162/074793603322545019.

Hatfield, H. *The Inventor and His World*. West Drayton, Middlesex: Penguin, 1948.

Hendy, David. *Noise: A Human History of Sound and Listening*.

Hornecker, Eva, and Jacob Buur. "Getting a grip on tangible interaction: a framework on physical space and social interaction." In *Proceedings of the SIGCHI conference on Human Factors in computing systems*, pp. 437-446. ACM, 2006.

Holman, David, and Roel Vertegaal. "Organic User Interfaces." *Communications of the ACM* 51, no. 6 (12, 2008): 48. doi:10.1145/1349026.1349037.

Holmes, Thom, and Terence M. Pender. *Electronic and Experimental Music: Technology, Music, and Culture*. New York: Routledge, 2012.

Hodges, D. Why are we musical? Speculations on the Evolutionary Plausibility of Musical Behavior. *Bulletin of the Council for Research in Music Education*, No. 99, pp.7-22.

Hunt, Andy, and Ross Kirk. "Mapping strategies for musical performance." *Trends in Gestural Control of Music* 21 (2000): 2000.

Hunt, Andy, and Ross Kirk. "Radical user interfaces for real-time control." In *EUROMICRO Conference, 1999. Proceedings. 25th*, vol. 2, pp. 6-12. IEEE, 1999.

Hunt, Andy, Marcelo M. Wanderley, and Matthew Paradis. "The importance of parameter mapping in electronic instrument design." *Journal of New Music Research* 32, no. 4 (2003): 429-440.

Isacoff, Stuart. *A Natural History of the Piano: The Instrument, the Music, the Musicians from Mozart to Modern Jazz, and Everything in between*. New York: Alfred A. Knopf, 2011.

Johnston, Andrew. "Beyond evaluation: Linking practice and theory in new musical interface design." *interpretation* 14 (2011): 105.

Johnstone, E.. The Rolky: A poly-touch controller for electronic music. In *Proc. of the International Computer Music Conference*, pages 291–295, 1985.

- Jordà, Sergi. "Digital Instruments and Players: Part II–Diversity, Freedom and Control." In *Proceedings of the International Computer Music Conference*, pp. 706-710. 2004.
- Jordà, Sergi. "Instruments and Players: Some Thoughts on Digital Lutherie." *Journal of New Music Research* 33, no. 3 (12 2004): 321-41.
doi:10.1080/0929821042000317886.
- Jordà, S. et al., 2007. The reacTable : Exploring the Synergy between Live Music Performance and Tabletop Tangible Interfaces. In *Proceedings of the first international conference on "Tangible and Embedded Interaction"*. Baton, pp. 139–146.
- Kandel, Eric R. *Principles of Neuroscience*. Appleton & Lange, 2005.
- Kaye, Joseph Jofish. "Evaluating experience-focused HCI." In *CHI'07 extended abstracts on Human factors in computing systems*, pp. 1661-1664. ACM, 2007.
- Ke, Y., Hoiem, D. & Sukthankar, R., 2005. Computer Vision for Music Identification 2 . Representing Audio as Images. In *Proceedings of Computer Vision and Pattern Recognition (CVPR'05)*. pp. 597–604.
- Kiefer, Chris, Nick Collins, and Geraldine Fitzpatrick. "HCI methodology for evaluating musical controllers: A case study." In *Proceedings of NIME*, vol. 8. 2008.
- K. Hinckley and M. Sinclair. Touch-sensing input devices. In *Proceedings of the SIGCHI conference on Human factors in computing systems: the CHI is the limit*, pages 223–230, 1999.
- Kiefer, Chris, Nick Collins, and Geraldine Fitzpatrick. "HCI methodology for evaluating musical controllers: A case study." In *Proceedings of NIME*, vol. 8. 2008.
- Kojs, Juraj, Stefania Serafin, and Chris Chafe. "Cyberinstruments via Physical Modeling Synthesis: Compositional Applications." *Leonardo Music Journal* 17 (12 2007): 61 66. doi:10.1162/lmj.2007.17.61.
- Krause, F. L.; Israel, J. H.; Neumann, J. and Beckmann-Dobrev, B: A 6-DOF User Interface for Grasping in VR-based Computer Aided Styling and Design. In: *Proceedings of the ACM Symposium on Virtual Reality Software and Technology (VRST)*, Monterey, CA, USA, ACM Press, 2005; p. 110-112.

- Laozi, and Jonathan Star. *Tao Te Ching: The Definitive Edition*. New York: Jeremy P Tarcher/Putnam, 2001. Print.
- Leman, Marc. *Embodied Music Cognition and Mediation Technology*. Cambridge, MA: MIT Press, 2008.
- Leman, Marc. *Music, Gestalt, and Computing: Studies in Cognitive and Systematic Musicology*. Berlin: Springer, 1997.
- Lipscomb, S.D. & Kim, E.M., 2004. PERCEIVED MATCH BETWEEN VISUAL PARAMETERS AND AUDITORY CORRELATES : AN EXPERIMENTAL MULTIMEDIA INVESTIGATION. In P. W. S. Lipscomb, R. Ashley, R.O. Gjerdingen, ed. *Proceedings of the 8th International Conference on Music Perception & Cognition*. Evanston, IL, pp. 72-75.
- Lobel, Thalma. *Sensation: The New Science of Physical Intelligence*.
- Loesser, Arthur. *Men, Women and Pianos: A Social History*. New York: Simon and Schuster, 1954.
- Lynch, Wilfred. *Handbook of Silicone Rubber Fabrication*. New York: Van Nostrand Reinhold, 1978.
- MacPherson, Fiona. *The Senses: Classic and Contemporary Philosophical Perspectives*. New York: Oxford University Press, 2011.
- Magnusson, T., 2005. IXI SOFTWARE : OPEN CONTROLLERS FOR OPEN SOURCE AUDIO SOFTWARE. In *Proceedings of the 2005 conference on New interfaces for musical expression*. Vancouver, Canada: MPublishing, University of Michigan Library.
- Malloch, Joseph, David Birnbaum, Elliot Sinyor, and Marcelo M. Wanderley. "Towards a new conceptual framework for digital musical instruments." In *Proceedings of the 9th International Conference on Digital Audio Effects*, pp. 49-52. 2006.
- Malloch, Joseph, Stephen Sinclair, and Marcelo M. Wanderley. "From controller to sound: Tools for collaborative development of digital musical instruments." In *Proceedings of the 2007 International Computer Music Conference, Copenhagen, Denmark*. 2007.
- Marshall, M.T. and M. M. Wanderley. Evaluation of sensors as input devices for computer music interfaces. In *Proc. Of Computer Music Modeling and Retrieval 2005 Conference, LNCS 3902. Berlin Heidelberg*, pages 130–139. Springer-Verilog, 2006.

- McCarthy, John, and Peter Wright. "Technology as experience." *interactions*11, no. 5 (2004): 42-43.
- McPherson, A., Adrian Gierakowski, and Adam M. Stark. 2013. The space between the notes:adding expressive pitch control to the piano keyboard. In *Proceedings of the SIGCHIConference on Human Factors in Computing Systems (CHI '13)*. ACM, New York, NY, USA, 2195-2204. DOI=10.1145/2470654.2481302
- McPherson, A., and Kim, Y. Design and applications of a multi-touch musical keyboard. In *Proc. SMC (2011)*.
- Mcpherson, Andrew P., and Youngmoo E. Kim. "The Problem of the Second Performer: Building a Community Around an Augmented Piano." *Computer Music Journal* 36, no. 4 (12 2012):10-27. doi:10.1162/COMJ_a_00149.
- McPherson, A., and Youngmoo Kim. 2010. Toward a computationally-enhanced acoustic grand piano. In *CHI '10 Extended Abstracts on Human Factors in Computing Systems (CHI EA'10)*. ACM, New York, NY, USA, 4141-4146. DOI=10.1145/1753846.1754116. <http://doi.acm.org/10.1145/1753846.1754116>
- Menzies, Duncan WH, and Andrew P. McPherson. "A Digital Bagpipe Chanter System to Assist in One-to-One Piping Tuition." (2013).
- Menzies, Duncan WH, and Andrew McPherson. "An Electronic Bagpipe Chanter for Automatic Recognition of Highland Piping Ornamentation." *Proc. NIME, Ann Arbor, MI, USA (2012)*.
- Miranda, Eduardo Reck, and Marcelo M. Wanderley. *New Digital Musical Instruments: Control and Interaction beyond the Keyboard*. Middleton, WI: A-R Editions, 2006.
- Moog, A., 2011. of the Keyboard The Interface : The Recording Piano Moog Sensitive Keyboards. *Computer Music Journal*, 14(2), pp.52–60.
- Muller, M. et al., 2011. Signal Processing for Music Analysis. *IEEE Journal of Selected Topics in Signal Processing*, 5(6), pp.1088–1110.
- M. Wright and A. Freed. Open Sound Control: A new protocol for communicating with sound synthesizers. In *Proceedings of the International Computer Music Conference, Aristotle University, Thessaloniki, Greece*, pages 101 – 104, 1997.

- Nicolls, Sarah. "Seeking Out the Spaces Between: Using Improvisation in Collaborative Composition with Interactive Technology." *Leonardo Music Journal* 20 (12 2010): 47-55. doi:10.1162/LMJ_a_00012.
- Norman, Donald A. *Living with Complexity*. Cambridge, MA: MIT Press, 2011.
- Norman, Donald A. *The Psychology of Everyday Things*. New York: Basic Books, 1988.
- Nussbaum, Charles O. *The Musical Representation: Meaning, Ontology, and Emotion*. Cambridge, MA: MIT Press, 2007.
- O'modhrain, Sile. "A framework for the evaluation of digital musical instruments." *Computer Music Journal* 35, no. 1 (2011): 28-42.
- Oosterhuis, K. Intuitive Three-Dimensional Sketching in Digital Space: The Synthesis of the Genetic Code for Buildings/Organisms *Leonardo*, Vol. 28, No. 2 (1995), pp. 123-127.
- Orio, Nicola, Norbert Schnell, and Marcelo M. Wanderley. "Input devices for musical expression: borrowing tools from HCI." *Proceedings of the 2001 conference on New interfaces for musical expression*. National University of Singapore, 2001.
- Ortmann, Otto. *The Physical Basis of Piano Touch and Tone; an Experimental Investigation of the Effect of the Player's Touch upon the Tone of the Piano*. London: K. Paul, Trench, Trubner &, 1925.
- Ostertag, Bob. "Human Bodies, Computer Music." *Leonardo Music Journal* 12 (12 2002): 11-14. doi:10.1162/096112102762295070.
- O'Sullivan, D. Choosing Tools for Virtual Environments, *Leonardo*, Vol. 27, No. 4 (1994), pp. 297-302.
- Paine, Garth. "Towards Unified Design Guidelines for New Interfaces for Musical Expression." *Organized Sound* 14, no. 02 (12 2009): 142. doi:10.1017/S1355771809000259.
- Parakilas, James. *Piano Roles: A New History of the Piano*. New Haven: Yale Nota Bene, 2002.
- Parakilas, James. *Piano Roles: Three Hundred Years of Life with the Piano*. New Haven: Yale University Press, 1999.

- Patel, Aniruddh D. *Music, Language, and the Brain*. Oxford: Oxford University Press, 2008.
- Paine, Gareth. "Towards a Taxonomy of Realtime Interfaces for Electronic Music Performance." In the *Proceedings of the Conference on New Musical Interfaces for Musical Expression*, pages 436-439, 2010.
- Peretz, Isabelle, and Robert J. Zatorre. *The Cognitive Neuroscience of Music*. Oxford: Oxford University Press, 2003.
- Pierce, John Robinson. *The Science of Musical Sound*. New York: Scientific American Library, 1983.
- Pinch, T. J., and Frank Trocco. *Analog Days: The Invention and Impact of the Moog Synthesizer*. Cambridge, MA: Harvard University Press, 2002.
- Pinker, Steven. *How the Mind Works*. New York: Norton, 1997.
- Polotti, Pietro, and Davide Rocchesso. *Sound to Sense, Sense to Sound: A State of the Art in Sound and Music Computing*. Berlin: Logos, 2008.
- Rabin, Ely, and Andrew M. Gordon. "Tactile Feedback Contributes to Consistency of Finger Movements during Typing." *Experimental Brain Research* 155, no. 3 (12, 2004): 362-69. doi:10.1007/s00221-003-1736-6.
- Raizman, David Seth. *History of Modern Design*. Upper Saddle River, NJ: Prentice Hall, 2004.
- Ramachandran, V. S. *The Tell-tale Brain: Tales of the Unexpected from inside Your Mind*. London: Windmill, 2012.
- Redström, Johan. "Towards User Design? On the Shift from Object to User as the Subject of Design." *Design Studies* 27, no. 2 (12 2006): 123-39. doi:10.1016/j.destud.2005.06.001.
- Rhodes, H., 2001. Harold Rhodes, 89, Inventor of an Electronic Piano. *The New York Times*, pp.12 13.
- Roads, Curtis. "Early Electronic Music Instruments: Time Line 1899-1950." *Computer Music Journal* 20, no. 3 (12 1996): 20. doi:10.2307/3680817.

- Russell, Raymond. *Early Keyboard Instruments*. London: H.M. Stationery Off., 1959.
- Rūmī, Jalāl Al-Dīn, and Coleman Barks. *The Essential Rumi*. San Francisco, CA: Harper, 1995.
- Schkolne, Steven. "Drawing with the Hand in Free Space: Creating 3D Shapes with Gesture in a Semi-Immersive Environment." *Leonardo* 35, no. 4 (12 2002): 371-75. doi:10.1162/002409402760181132.
- Schwesig, C., Poupyrev, I. & Mori, E., 2004. Gummi: a bendable computer. In *Proceedings of the CHI 2004 Conference on Human Factors in Computing Systems*. Vienna, Austria: ACM, pp. 263–270.
- Sengers, Phoebe, and Bill Gaver. "Staying open to interpretation: engaging multiple meanings in design and evaluation." In *Proceedings of the 6th conference on Designing Interactive systems*, pp. 99-108. ACM, 2006.
- Sennett, Richard. *Together: The Rituals, Pleasures, and Politics of Cooperation*. New Haven, CT: Yale University Press, 2012.
- "Sensors and Actuators A." *Sensors and Actuators B: Chemical* 85, no. 3 (12 2002): II. doi:10.1016/S0925-4005(02)00235-6.
- Smela, E. "Conjugated Polymer Actuators for Biomedical Applications." *Advanced Materials* 15, no. 6 (12, 2003): 481-94. doi:10.1002/adma.200390113.
- Sterne, Jonathan. *MP3: The Meaning of a Format*. Durham: Duke University Press, 2012.
- Sterne, Jonathan. *The Audible Past: Cultural Origins of Sound Reproduction*. Durham: Duke University Press, 2003.
- Stowell, Dan, Mark D. Plumbley, and Nick Bryan-Kinns. "Discourse analysis evaluation method for expressive musical interfaces." In *Proceedings of the International Conference on New Interfaces for Musical Expression (NIME)*, pp. 81-86. 2008.
- Sudnow, David, and Hubert L. Dreyfus. *Ways of the Hand: A Rewritten Account*. Cambridge, MA: MIT Press, 2001.
- Sundin, Martin, and Morten Fjeld. "Softly Elastic 6 DOF Input." *International Journal of Human Computer Interaction* 25, no. 7 (12, 2009): 647-91. doi:10.1080/10447310902964124.

- Swann, Cal. "Action Research and the Practice of Design." *Design Issues* 18, no. 1 (12 2002): 49-61. doi:10.1162/07479360252756287.
- Théberge, Paul. *Any Sound You Can Imagine: Making Music/consuming Technology*. Hanover, NH: Wesleyan University Press, 1997.
- Thrasher, Alan R. *Chinese Musical Instruments*. New York: Oxford UP, 2000. Print.
- Ullmer, B., and H. Ishii. "Emerging Frameworks for Tangible User Interfaces." *IBM Systems Journal* 39, no. 3.4 (12 2000): 915-31. doi:10.1147/sj.393.0915.
- Ullmer, B., and H. Ishii. The metaDESK: Models and Prototypes for Tangible User Interfaces. In: Proceedings of UIST'97. New York, USA, ACM Press, 1997 pp.223-232.
- Vertegaal, R., T. Ungvary, and M. Kieslinge. Towards a musician's cockpit: Transducers, feedback and musical function. In *Proc. of the International Computer Music Conference*, pages 308-311, 1996.
- Vertegaal, R. & Poupyrev, I., 2008. Organic User Interfaces. *Communications of the ACM*, 51(6), p.26.
- Wallin, Nils Lennart., Björn Merker, and Steven Brown. *The Origins of Music*. Cambridge, MA: MIT Press, 2000.
- Warner, M., and E. M. Terentjev. *Liquid Crystal Elastomers*. Oxford: Oxford University Press, 2003.
- Wessel, David, and Matthew Wright. "Problems and prospects for intimate musical control of computers." *Computer Music Journal* 26, no. 3 (2002): 11-22.
- Whitehead, Alfred North. *The Concept of Nature*. Ann Arbor: University of Michigan Press, 1957.
- Williamon, Aaron. *Musical Excellence: Strategies and Techniques to Enhance Performance*. Oxford: Oxford University Press, 2004.
- Window, A. L., and G. S. Holister. *Strain Gauge Technology*. London: Applied Science, 1982.

Xiao, X. & Ishii, H., 2011. Duet for solo piano: MirrorFugue for single user playing with recorded performances. In *Proceedings of the 2011 ACM SIGCHI Conference on Human Factors in Computing Systems*. Vancouver, BC, Canada: ACM, pp. 1285-1290.

Xiao, X., Gust, L. & Ishii, H., 2012. MirrorFugue2 : Embodied Representation of Recorded Piano Performances. In *Proceedings of the 2012 Interactive Tabletops & Surfaces (ITS)*. Cambridge, MA, pp. 2-5.

Yonezawa, T. & Mase, K., *Tangible Sound : Musical Instrument Using Fluid Media* ≠ Keio University Graduate School of Media and Governance, Kyoto.

Index

Abstraction, 24, 45-48, 57- 59, 61- 64, 101, 129, 130

Aftertouch. 61, 72, 84, 98, 123

Chassis, 86, 90, 91, 93, 96, 102, 103, 105, 109, 116, 120

Continuity, 24, 45-48, 59, 61, 62, 129

Continuous touch, 92, 111, 112, 118

Continuum, 70, 90, 117, 122

Discreteness, 24, 38, 45-48, 59, 61, 62, 129

Elastomer, 76, 84, 86, 90, 93, 96, 97, 102-106, 109, 116, 120, 121

Gesture, 23, 44, 46, 58, 61, 64, 70, 74, 85, 100, 111, 117, 121 122, 129

Immediacy, 24, 37, 46-48, 58, 59, 61, 116

Keyboard, 22, 24, 48-54, 56, 60-62, 64, 70-74, 84, 86, 92, 93, 96, 101, 102, 111, 117, 120, 123, 126, 127

Piano, 22-24, 27, 28, 38, 45, 47, 48, 50, 51, 53, 54, 55, 56, 61, 64, 70-74, 86, 96, 117, 120, 124, 126, 127

Pitchbend, 73, 92

Softness, 84, 128

TouchKeys, 32, 72, 126

Endnotes

¹ Rumi, (1995, 391)

² From *The Revenge of the Intuitive*, WIRED Magazine, Issue 7.01, Jan 1999

³ Holmes, (2012, 3)

⁴ Marx, 2011 *The Economic and Philosophical Manuscripts; 3rd edition*

⁵ The following discussion of neuroscience and philosophy of mind is not intended as a scholarly summary of either field or an argument in favor of a particular interpretation of the fields in conjunction. The assertions are generally not controversial ones, bearing in mind that nearly everything is controversial if you look hard enough. Rather than referencing each claim, I suggest a few books which are good introductions to the fields in questions: Pinker, *How the Mind Works*; Ramachandran, *The Tell-tale Brain*, Macpherson (2011), Patel (2008).

⁶ Macpherson (2011,15)

⁷ Marx, 2011 *The Economic and Philosophical Manuscripts; 3rd edition*

⁸ For an excellent discussion of how our 'common sense' view of our sense of sound and sense of sight turns out to be problematic, especially with respect to categories of interior and exterior, see Chapter 2 of *The Audible Past*, Sterne (2003)

⁹ *Music, Language, and the Brain*, by Patel, Aniruddh D, p.3. This book is generally the best overview of the topic of musical cognition and linguistic neuropsychology. For a popular, less scholarly discussion of some of the same themes, see pp. 528-538 in Stephen Pinker's *How the Mind Works*.

¹⁰ Chapter 3 of *The Tell-Tale Brain* by V.S. Ramachandran has an excellent discussion on synesthesia. The research he recounts primarily focuses on associations between the senses which are odd or unusual. It is valuable to make a distinction between conditioned synesthesia as opposed to synesthesia which may be associated with different brain architecture of function. Conditioned synesthesia would cover rather than what Ramachandran calls "a surreal blending of sensation, perception, and emotion," rather a real and ordinary blending of sensation, perception and emotion that nevertheless creates multi-modal intuitions and expectations which are highly relevant to the interactive designer.

¹¹ *The Science of Musical Sound* by John R Pierce (1983, 5)

¹² I have found it helpful to make a distinction between two different levels of intuition or learned associations. *Fundamental intuitions* are those that arise from all human experience, whereas *trained intuitions* arise from particular forms of training. Certain

associations between touch and sound and visual representations of state are product elements that relate to fundamental intuitions. The idea that on a Continuum pitch is mapped from left to right low to high is a response to a *trained intuition*. Given the relationship with a keyboard, it would be highly unintuitive for pitch to be mapped from right to left low to high. But this would go against the gain of a trained intuition rather than a fundamental intuition. Velocity/volume being mapped such that it increases from a light touch to a hard touch builds off a fundamental intuition rather than a trained intuitions, because such is the property of all our everyday physical interactions.

¹³ Jonathan Sterne in *The Audible Past* (2003, 23)

¹⁴ Ibid p. 23

¹⁵ Incidentally, the third most important category of musical perception is harmony, or multi-vocalisation. Where pure vocalisation evokes individual human consciousness, and impact evokes the physical, multi-vocal harmonies carry with them the association of sociality.

¹⁶ Journal of Human Evolution Volume 62, Issue 6, June 2012, Pages 664–676, *Testing models for the beginnings of the Aurignacian and the advent of figurative art and music: The radiocarbon chronology of Geißenklösterle*, Thomas Higham, Laura Basell, Roger Jacobi, Rachel Wood, Christopher Bronk Ramsey, Nicholas J. Conard)

¹⁷ For more on the differences between rhythm in speech and music see Chapter 3 of *Music, Language, and the Brain*, Patel, Aniruddh D.

¹⁸ Dean, *The Drum: A History*, (2012, 5-6)

¹⁹ *Psychobiology of Musical Gesture: Innate Rhythm, Harmony and Melody in Movements of Narration*, Trevarthen, Delafield-Butt, and Schogler, in *New Perspective on Music and Gesture*, Edited by Anthony Gritten and Elaine King.

²⁰ Bradley, Arthur, *A Language of Emotion: What Music Does and How It Works* (2009, 7)

²¹ To be slightly more technical, a point is an example of one-dimensional spatial discreteness, and a line an example of one-dimensional spatial continuity. A triangle is an example of two-dimensional spatial continuity, and a cube an example of three dimensional spatial continuity and so forth.

²² See for example, Fingelkurts and Fingelkurts, *Imaging Cognition and EEG Brain Dynamics: Discreteness versus Continuity* in which they conclude that “brain functioning is best conceptualized in terms of continuity-discreteness unity which also the characteristic property of cognition” (from the abstract).

²³ For a fascinating case study in this regard, see Paul M. Churchland’s *Plato’s Camera: How the Physical Brain Capture a Landscape of Abstract Universals*, in which he investigates how we develop a background framework that informs our immediate perceptions and categorizations.

²⁴ See Purpura, DP *Functional Studies of Thalamic Internuclear interactions, Brain Behavior*, 6:203-234 1972

²⁵ As a footnote, my earlier studies in mereology and process ontology suggested that one may be able to trace the importance of the themes of discreteness and continuity back even deeper than our primordial associations with voice and impact. The division between things and processes, between nouns and verbs arises in part from the relative speed of transformation.

²⁶ Brian Eno, *The Revenge of the Intuitive*, WIRED Magazine, Issue 7.01 | Jan 1999

²⁷ Théberge, Paul. *Any Sound You Can Imagine: Making Music/consuming Technology*. (1997, 1)

²⁸ Marshall McLuhan, 1962 *The Gutenberg Galaxy: The Making of Typographic Man*, p. 4

²⁹ Other useful books include *A Natural History of the Piano: The Instrument, the Music, the Musicians--from Mozart to Modern Jazz and Everything in Between* by Stuart Isacoff, 2011.

³⁰ *A New History of the Organ: From the Greeks to the Present Day*, Peter Williams (1980, 28)

³¹ In the social history of tool use, tools have always had a double-edge psychological status. On the one hand, they are sources of human power and thus the tools and their skilled users usually gain a certain degree of respect and recognition. At the same time, what the tool allows is in many cases just a more effective form of labour, and as such even skilled users are still subordinated into the political system. The most powerful form of control was not the use of tools, but the power to command and control the tool users. The gods were enthroned, seated, and capable of powerful intervention through a word, a thought, or the movement of a finger. This reflection of human attitudes towards tool use and power as amplified in the transition from polytheistic pantheons of gods—with particular powers, and in many cases powerfully enchanted tools—to a monotheistic God who created with words and ruled omnipotently.

³² Apparently Jaron Lanier makes a similar claim about a Chinese mouth organ. In *How Music Works*, David Byrne, writes "He [Jaron Lanier] claimed that this instrument [a Chinese mouth organ called a *sheng*] was maybe the first in which the notes to be played were chosen by a mechanism, a mechanism that was a precursor to binary theory and thus all computers." See also page 5-7 of *Chinese Musical Instruments*.

³³ *A New History of the Organ: From the Greeks to the Present Day*, Peter Williams (1980, 46)

³⁴ One of the important costs, though, of this domestication comes with the 12 tone scale.

³⁵ Ernest Closson, *History of the Piano*, (1974, 11)

³⁶ Ibid. p. 44

³⁷ *Piano Roles* by James Parakilas (2000, 5)

³⁸ In *Physics* by Charles Riborg Mann and George Ransom Twiss (1910)

³⁹ *The Work of Art in the Age of Mechanical Production*, Walter Benjamin (1936)

⁴⁰ On the history of recording technologies, *The Audible Past* is an excellent post-modern look at the history of sound recording and its cultural meaning and impact. *Electronic and Experimental Music* is a superb overview to the field.

⁴¹ This lack of binary or one-dimensional controls is true of almost all acoustic instruments, though organs are an important exception here.

⁴² For a clear overview of the innovations in this area in the first half of the twentieth century, see C. Roads, *Early Electronic Music Instruments: Time Line 1899 – 1950*.

⁴³ And there were a number of early pre-cursors which bear mentioning, such as the Ondes Martinot (figures 25-26) and a range of other experiments in keyboard and organ design in the early twentieth century which set the stage for the groundbreaking innovations of the synthesizer.

⁴⁴ Moog and Rhea, *Evolution of the Keyboard Interface: the Bosendorfer 290SE Recording Piano and the Moog Multiply-Touch-Sensitive Keyboards*, and J. Eaton and R Moog, *Multiple-Touch-Sensitive Keyboard*. Moog was not alone in pushing the boundaries of the piano keyboard – other notable recent work not mentioned elsewhere includes MacPherson and Kim's Resonant Piano (see *Toward a Computationally-Enhanced Acoustic Grand Piano*) and Freed and Avizienis's *A New Music Keyboard with Continuous Key-position Sensing and High-speed Communication*. Also see Niccols (2010)

⁴⁵ Paul Theberge, *Any sound you can imagine; making music/consuming technology*. p. 87. There are some common workarounds for multi-dimensional controllers like setting up multiple MIDI channels, and there have been some very successful and important wind based controllers, like the EWI (electronic wind instrument) and others. These have provided a compelling source of sonic inspiration for the Seaboard.

⁴⁶ Gareth Paine, *Towards Unified Design Guidelines for New Interfaces for Musical Expression* (2009, 142)

⁴⁷ Ibid. p. 142

⁴⁸ <http://madronalabs.com/hardware> (circa April 2014)

⁴⁹ <http://www.eigenlabs.com/info/> (circa April 2014)

-
- ⁵⁰ *The Inventor - His World and His Inventions*, H Stafford Hatfield (c.1930)
- ⁵¹ Katie Hafner, *A Romance on Three Legs: Glenn Gould's Obsessive Quest for the Perfect Piano* (2009, 94-95)
- ⁵² The keyboardist of Jethro Tull captured best the problem of precision in the use of pitch wheels when he told me, 'There are a number of great Waggle Merchants out there, and I've done a fair bit of waggling in my time, but this [the Seaboard] gives a much finer range of control.'
- ⁵³ TouchKeys is extremely well documented, and McPherson's scholarship sheds light on many concerns that are relevant to the Seaboard. See McPherson, *TouchKeys: Capacitive Multi-Touch Sensing on a Physical Keyboard*, and McPherson and Kim, *Design and Applications of a Multi-Touch Keyboard*.
- ⁵⁴ Aristotle, *Nicomachean Ethics*, p. 1
- ⁵⁵ Sergi Jorda, *Instruments and Players; some thoughts on digital lutherie* (2005, 1)
- ⁵⁶ Richard Sennett, *Together* (2012, 18)
- ⁵⁷ Ibid, p.19
- ⁵⁸ O'Modhrain *A framework for the evaluation of digital musical instruments* (2013)
- ⁵⁹ Tao Te Ching, poem 76, translated by the author, see also Star, *Tao Te Ching*
- ⁶⁰ Raizman, David Seth. *History of Modern Design* (2004, 396)
- ⁶¹ Boris Berman *Notes from the Pianist's Bench*, (2000, 4)
- ⁶² Aware that the pitch of a sound depends on its wavelength, Newton invented a toy—a musical keyboard—that flashed up different colors on a screen for different notes. Thus every song was accompanied by a kaleidoscope display of colors. As recounted in *The Tell-Tale Brain* by V.S. Ramachandran (2012, 77)
- ⁶³ Duke Ellington (1931)
- ⁶⁴ Donald A. Norman, *The Psychology of Everyday Things* (1988, 197)
- ⁶⁵ *The Concept of Nature*, A. N. Whitehead (1936)
- ⁶⁶ Johan Redstrom *Towards user design, On the shift from object to user as the subject of design* (2006, 131)
- ⁶⁷ *Design Methods 1* by Robert Curedale (2012, 324)

⁶⁸ Herbert Simon, *Science of the Artificial*, 1969

⁶⁹ I use the term *creator* rather than user. There is some question about whether user-centered design is to be preferred to people-centered design. People-centered is probably too broad – designs should be designed for a particular community who will benefit from them rather than the abstract person. Having said that, the word user implies only use, which narrowly emphasizes functionality. A case can be made for words like agent, or subject, in general, but when a more specific characteristic is available, it can be a stronger orientation. In the case of the Seaboard, the Seaboard is a tool for creating music, so people using it are creators, and the approach I have taken can be called creator-centered design.

⁷⁰ Robert Moog, quoted in *Analog Days*

⁷¹ Moog and Rhea (1985)

⁷² Donald A Norman, *Living with Complexity* (2011, 40)

⁷³ Holmes (2012, 3)

⁷⁴ 1925, Otto Ortmann *The Physical basis of Piano Touch and Tone*, pp. v-vi. For a more up-to-date paper (still) investigating a similar topic see Goebel, Bresin, and Galembo, *Once again: The perception of piano touch and tone. Can touch audibly change piano sound independently of intensity?* Their conclusions are similar, with the exception of noting that in some cases the nature and quality of the touch creates an acoustic sound based on the impact of the finger on the key. It is worth noting that one noticeable feature of Seaboard playing is that fingers on the elastomer make almost no noise whatsoever, compared to the very loud action of a mechanical key with a piano or even electric keyboard.

⁷⁵ Ibid, p. 171

⁷⁶ Ferruccio Busconi *Sketch of a New Esthetic of Music (1911)* in *Three Classics in the Aesthetic of Music* (1962); pp. 89-95

⁷⁷ <https://www.facebook.com/TrinityLabanSeaboardGroup> (circa April 2014)

⁷⁸ Marquis Scipione Maffei, 1709 (as quoted in pp.33-34 of *Men, Women, and Pianos*), on the pianoforte

⁷⁹ Two small further points to make on this front. First, MacPherson and Kim have provided a useful roadmap for establishing the early stages of ecosystem adoption in *The Problem of the Second Performer: Building a Community around an Augmented Piano*. The second is that although this cannot be judged at this stage, the Seaboard appears to be off to a good start with an exciting group of artists already using the Seaboard on tour and in recordings.

⁸⁰ At every stage, it is essential to clearly articulate and prioritize goals. In particular, it is helpful to take a precise approach to breaking complex propositions down into sets of simple propositions. Trying to invent a red ball that cures cancer is different than trying to invent something which (a) is red, (b) is a ball, and (c) cures cancer. With the second list, once complex propositions have become simple, you can reprioritize (a), (b) and (c).

⁸¹ *Audio Culture, Readings in Modern Music*, ed. Cristoph Cox and Daniel Warner (2004, 174)