



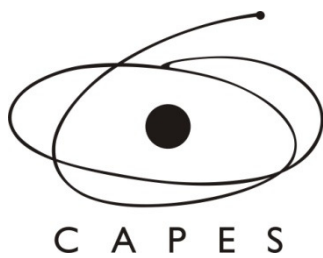
# PARADIGM SHIFT

The aesthetic of the automobile in the age of sustainability

**Artur Grisanti Mausbach**

Thesis submitted to the Board of Research of the Royal College of Art for the degree of  
Doctor of Philosophy.

March 2010



**Royal College of Art**  
Postgraduate Art & Design

"This text represents the submission for the degree of Doctor of Philosophy at the Royal College of Art. This copy has been supplied for the purpose of research for private study, on the understanding that it is copyright material, and no quotation from the thesis may be published without proper acknowledgment".



# Frontispiece

## Abstract

A great challenge for a future sustainable society is to create a new design culture protecting environmental value. A new product's language is determinant not only for marketing success and public acceptance, but also for a new understanding of the conflict between aesthetics and ethics that haunts the development of this new design language. The designer's approach to the new trends will certainly deal with the relationship between industry and society, form and function, package and architecture, and it is an opportunity to create new and coherent design.

These changes introduce new questions for vehicle design:

**How will the tradition of vehicle design influence this new aesthetic?**

**Will a new language change the image of the car as an enemy of the environment?**

**What will be the relationship between technology and aesthetics in the sustainable car?**

**How will the aesthetic of the automobile manifest itself in an age of sustainability?**

The hypothesis of this research is that new cars designed according to principles of environmental sustainability, will create a specific market and aesthetic, and consequently a new style. This segment will progressively take over the market, as sustainable cars become ubiquitous.

The research investigates both the industry and users to understand how society can be transformed towards a more sustainable future. The research firstly identifies design trends for environmental sustainability in the development of new cars; secondly studies the new aesthetics, and thirdly defines the conceptual design and profile of a new vehicle which would correspond with the expectations of a sustainable society.

In addition, the research includes the development of proposals for car concepts designed according to principles of environmental sustainability, with their own specific new style. It is developed as practice-based work, as a design process, including sketching and modelling, in order to produce experiments for constant verification of the hypothesis.

# Contents

Frontispiece .....	3
Abstract .....	4
Contents .....	5
List of Figures .....	9
List of Tables .....	18
Acronyms and Abbreviations .....	19
Acknowledgment .....	20
Author's Declaration .....	21
1. Introduction .....	22
2. Literature Review .....	33
2.1. The Automobile and Sustainability .....	35
2.1.1. The impacts of mobility .....	35
2.1.2. Crisis and Opportunity .....	43
2.1.3. Sustainable Development .....	44
2.1.4. Sustainable Design .....	45
2.1.5. Life Cycle Analysis .....	50
2.1.6. Improving the traditional model .....	55
2.1.7. Energy and engines .....	59
2.1.8. Biofuel .....	62
2.1.9. Hybridization .....	65
2.1.10. Battery Electric Vehicle .....	68
2.1.11. Hydrogen .....	71
2.1.12. Solar and Wind Power .....	73
2.1.13. Aerodynamics .....	75
2.1.14. Rolling Resistance .....	79
2.1.15. Design Concept .....	81
2.2. The Automobile and Aesthetics .....	85

2.2.1.	Introduction .....	85
2.2.2.	A story of fantastic artistry and inventiveness.....	92
2.2.3.	The Age of Pioneers .....	94
2.2.4.	The Evolutionary Age .....	107
2.2.5.	The Age of Sustainability.....	146
2.3.	Conclusion .....	164
3.	Methodology .....	169
3.1.	Design model .....	170
3.2.	Research stages .....	172
3.2.1.	Literature review .....	172
3.2.2.	Case studies.....	173
3.2.3.	Project .....	174
4.	Case Studies.....	176
4.1.	Smart .....	177
4.1.1.	Introduction .....	177
4.1.2.	History of the company.....	179
4.1.3.	Smart and sustainability.....	183
4.1.4.	The Fortwo .....	184
4.1.5.	Driving the Smart.....	190
4.1.6.	Conclusion.....	191
4.2.	Venturi .....	192
4.2.1.	Introduction .....	192
4.2.2.	History of Venturi.....	193
4.2.3.	Venturi and sustainability.....	196
4.2.4.	The Fétish .....	197
4.2.5.	The Astrolab .....	202
4.2.6.	The Eclectic.....	207
4.2.7.	Driving an electric car.....	213
4.2.8.	Conclusion.....	214

4.3.	Prius.....	216
4.3.1.	Introduction .....	216
4.3.2.	Toyota and sustainability.....	217
4.3.3.	Toyota’s ecological portfolio .....	219
4.3.4.	The Prius.....	222
4.3.5.	Driving the Prius.....	231
4.3.6.	Conclusion.....	232
4.4.	Conclusion .....	234
5.	Project.....	235
5.1.	Frisbee and Freedom.....	245
5.1.1.	Freedom in the Age of Sustainability .....	246
5.1.2.	Project challenges .....	247
5.1.3.	Conceptualization phase .....	248
5.1.4.	Experimentation phase.....	252
5.2.	Fluid and Speed.....	258
5.2.1.	Speed in the Age of Sustainability .....	259
5.2.2.	Project challenges .....	260
5.2.3.	Conceptualization phase .....	260
5.2.4.	Experimentation phase.....	265
5.3.	Core and Comfort.....	270
5.3.1.	Comfort in the Age of Sustainability .....	271
5.3.2.	Project challenges .....	271
5.3.3.	Phase of conceptualization.....	272
5.3.4.	Experimentation phase.....	275
5.4.	Evaluation .....	280
5.4.1.	Stéphane Schwarz addresses the Paradigm Shift Project .....	281
5.4.2.	Christopher Reitz addresses the Paradigm Shift Project .....	282
5.4.3.	Aesthetics of the Paradigm Shift Project .....	283
5.4.4.	Sustainability of the Paradigm Shift Project.....	287

5.4.5.	Validation .....	288
5.5.	Conclusion .....	289
6.	Conclusion, recommendations and future research .....	290
6.1.	Conclusion .....	290
6.2.	Recommendations.....	297
6.3.	Future research.....	299
	Bibliography.....	300
	Appendix .....	312

# List of Figures

Figure 1: Mies van der Rohe, German Pavilion, Barcelona (1929).....	24
Figure 2: Fritz Lang, Metropolis (1927) .....	25
Figure 3: Robert Moses, Lower Manhattan Expressway, New York (1962) .....	26
Figure 4: Lucio Costa, Monumental Axle, Brasilia (1960) .....	27
Figure 5: Norman Foster, Masdar (2006) .....	28
Figure 6: Per Capita GDP and Vehicles (Gott, 2008). .....	39
Figure 7: Chinese symbol for 'crisis' .....	43
Figure 8: Smart Fortwo (2008) .....	48
Figure 9: Description of ELV Arising and Treatment in Europe (GHK, 2006) .....	52
Figure 10: BMW 118d (2008).....	56
Figure 11: Zaha Hadid BWM Central Building, Leipzig (2005).....	58
Figure 12: Resources, Fuels and Engines (Kloess et al. 2008). .....	59
Figure 13: Saab 93 Convertible BioPower (2008). .....	63
Figure 14: The Three Basic Kinds of Hybridization (AVERE, 2008). .....	66
Figure 15: Toyota Prius (2004).....	66
Figure 16: Baker Electric (1911). .....	68
Figure 17: Pile of Crushed EV1s. ....	69
Figure 18: Tesla Roadster (2007). .....	70
Figure 19: BMW Hydrogen 7 in a hydrogen fuelling station. ....	72
Figure 20: GM Autonomy Skateboard Architecture (2002).....	73
Figure 21: Venturi Eclectic (2006).....	74
Figure 22: Il Delfino (1956).....	77
Figure 23: Pininfarina CNR Research Model (1978).....	77
Figure 24: GM EV1 (1997). ....	77
Figure 25: Audi A2 (1999).....	78
Figure 26: Toyota Prius (2004).....	78
Figure 27: Honda Insight (2010).....	78
Figure 28: Dunlop Pininfarina Ultra-Light Weight Tyre (2009). ....	80

Figure 29: Better Place Electric Car Battery Swap Station (2009).....	84
Figure 30. A red rose.....	85
Figure 31. The Victory of Samothrace (Approximately 200 B.C.).....	90
Figure 32: Geraldo Dottori, Trittrico della velocita - III) L'arrivo (1926).....	91
Figure 33: Benz Patent Motorwagen (1886). ....	94
Figure 34: La Jamais Contente (1899).....	95
Figure 35: Mercedes 35HP (1901). ....	96
Figure 36: Ford Model T production line.....	97
Figure 37: Rolls-Royce Silver Ghost (1912). ....	98
Figure 38: Bugatti Type 35 (1924). ....	99
Figure 39: Bugatti Type 57 Atlantic (1937). ....	100
Figure 40: Buick Y-Job Concept Car (1937).....	101
Figure 41: Alfa Romeo 8C 2900 (1935). ....	102
Figure 42. Citroen 11CV Traction Avant (1934).....	103
Figure 43: Volkswagen Prototype (1935). ....	104
Figure 44: Jeep (1941). ....	105
Figure 45: Citroen 2CV (1948).....	106
Figure 46: Cisitalia 202 (1947).....	109
Figure 47: Porsche 356 (1948). ....	110
Figure 48: Citroen DS (1957).....	111
Figure 49: BMW Isetta (1955). ....	112
Figure 50: FIAT Nuova 500 (1957).....	112
Figure 51: The Mini in the film <i>The Italian Job</i> (1969). ....	113
Figure 52: Lockheed P-38 Lightning (1941). ....	114
Figure 53: Oldsmobile Rocket 88 advertising (1951). ....	115
Figure 54: Jaguar XK120 (1949).....	116
Figure 55: Jaguar E-type (1961).....	117
Figure 56: Dino 206 (1967).....	118
Figure 57: Porsche 911 (1963). ....	118



Figure 58: Chevrolet Corvette Sting Ray (1963).....	119
Figure 59: Ford Mustang (1964).....	119
Figure 60: Lincoln Continental Mark IV (1972).....	120
Figure 61: <i>Il Carroziere Italiano</i> magazine cover with the Fissore Aruanda concept (1965).....	121
Figure 62: Italdesign Bizzarrini Manta concept (1968).....	122
Figure 63: Bertone Carabo Alfa Romeo 33 concept (1968).....	122
Figure 64: Lotus Esprit (1976).....	123
Figure 65: Lancia Stratos (1973).....	123
Figure 66: Porsche 928 (1978).....	124
Figure 67: Giugiaro's drawing of the Volkswagen Golf.....	125
Figure 68: Giugiaro's drawing of the Lancia Delta.....	127
Figure 69: Audi Quattro rally car (1983).....	127
Figure 70: Senna's McLaren and Prost's Ferrari racing cars (1990).....	128
Figure 71: Ferrari F40 (1987).....	129
Figure 72: Jeep Cherokee (1984).....	130
Figure 73: Porsche Cayenne (2008).....	131
Figure 74: Renault Twingo (1993).....	132
Figure 75: Renault Mégane Scenic (1996).....	133
Figure 76: BMW Mini (2002).....	134
Figure 77: Golf blueprint over the New Beetle.....	135
Figure 78: Audi TT (1998).....	135
Figure 79: GM EV1 (1996).....	136
Figure 80: Mercedes Benz A-Class (1997).....	137
Figure 81: Zaha Hadid installation at Venice Architecture Biennale (2008).....	138
Figure 82: BMW GINA Light Concept (2008).....	138
Figure 83: BMW 5-series (2003).....	139
Figure 84: Cadillac STS (2005).....	139
Figure 85: Raul Pires drawings of the Bentley Continental GT.....	140
Figure 86: Alfa Romeo 156 Sportwagon (1997).....	142

Figure 87: Hummer H3 and VW Polo in the streets of London. ....	143
Figure 88: Audi A2 (1999).....	144
Figure 89: Toyota Prius (2004).....	144
Figure 90: Smart Fortwo in the streets of New York. ....	145
Figure 91: Fiat Ecobasic Concept (2000). ....	147
Figure 92: Citroen C-Cactus concept (2007).....	148
Figure 93: Mercedes-Benz Bionic Concept (2005). ....	148
Figure 94: McLaren F1 (1994). ....	149
Figure 95: Mazda Taiki concept (2007).....	149
Figure 96: Mazda Taiki concept (2007).....	150
Figure 97: Mazda Taiki concept (2007).....	150
Figure 98: BMW Vision concept (2009). ....	151
Figure 99: BMW Vison concept (2009). ....	152
Figure 100: Lamborghini Marzal concept (1967). ....	152
Figure 101: GM Autonomy Concept (2003).....	153
Figure 102: Giugiaro's Trilogy on a Fun Theme (1988).....	154
Figure 103: Giugiaro Vad.ho concept (2007).....	154
Figure 104: Toyota Alessandro Volta concept (2004). ....	155
Figure 105: Tesla Roadster (2008). ....	156
Figure 106: Chevrolet Volt (2010).....	156
Figure 107: Morgan LIFE Car concept (2009).....	157
Figure 108: GM Jay Leno Eco-Jet concept (2006).....	158
Figure 109: Fisker Karma (2009).....	158
Figure 110: Pininfarina Sintesi concept (2008). ....	159
Figure 111: Giugiaro Quaranta concept (2008).....	160
Figure 112: Fioravanti Thalia concept (2007). ....	161
Figure 113: Pininfarina Bo concept (2009).....	161
Figure 114: Pininfarina Bo concept (2009). ....	162
Figure 115: Renault Twizy Z.E. concept (2009). ....	162

Figure 116: Nissan Pivo 2 concept (2007). .....	163
Figure 117: Benz Patent and Mercedes-Benz Fuel Cell Roadster.....	168
Figure 118: Paradigm Shift Research Method Map.....	169
Figure 119: Design models used as references: (top) Design Process by Pahl and Beitz, (bellow) Three Phase Model and Men-Tool-Work-Environment System by Archer. ....	171
Figure 121: Smart Fortwo (2007). .....	177
Figure 120: Smart logo. ....	177
Figure 122: Swatch watches.....	179
Figure 123: Eco Sprinter Concept (1993). .....	180
Figure 124: Smart Atlanta Show Car (1996). ....	180
Figure 125: Smart City-Coupé Fashion Victim Concept (1997).....	180
Figure 126: Smart Roadster (2003). .....	181
Figure 127: Smart Forfour (2004). .....	181
Figure 128: Smart Crossblade (2002). .....	182
Figure 129: Smart Crosstown Concept (2005).....	182
Figure 130: MCC Smart City-Coupe (1997). .....	184
Figure 131: Smart Fortwo Electric Drive (2008). .....	186
Figure 132: Competitors of the Smart Fortwo: Microcar M.Go Electric, Elettrica Electric, Xiao Ya, Nice MyCar Electric, Lumeneo Smera, Mega E-City, Reva G--Wiz and Toyota Iq. ....	187
Figure 133: Design analysis of the Smart Fortwo.....	189
Figure 134: Smart Cabrio in the narrow streets of Castelsardo, Sardinia, Italy (2007).....	190
Figure 135: Smart Cabrio in Alghero, Sardinia, Italy (2007). .....	191
Figure 136: Venturi logo. ....	192
Figure 137: MVS Venturi 200 (1987).....	193
Figure 138: Venturi 300 (1991). .....	193
Figure 139: Venturi 400GT (1993).....	194
Figure 140: Venturi LM (1993). ....	194
Figure 141: Venturi Fétish concept (ICE) (2002). .....	195
Figure 142: Venturi Grand Prix (2003) .....	195
Figure 143: Venturi's slogan plate.....	196

Figure 144: Venturi Fétish in the streets of Monte Carlo.....	197
Figure 145: Competitors of the Venturi Fétish: Audi E-tron and Tesla Roadster.....	199
Figure 146: The interior of the Venturi Fétish.....	200
Figure 147: Design analysis of the Venturi Fétish.....	201
Figure 148: Venturi Astrolab concept (2006).....	202
Figure 149: Noun Solar Team Nuna 3 solar-powered racing car (2004).....	203
Figure 150: Swarovski Crystal Aerospace Car.....	203
Figure 151: Two other concept cars with a Cockpit Body: Rinspeed Exaxis and Giugiaro VAD HO .....	204
Figure 152: Design analysis of the Astrolab.....	205
Figure 153: Design analysis of the Astrolab.....	206
Figure 154: Venturi Eclectic concept (2006).....	207
Figure 155: Venturi Eclectic production model (2009).....	207
Figure 156: Solarshuttle 66.....	208
Figure 157: Citroen Mehari.....	208
Figure 158: Venturi Eclectic (2009).....	209
Figure 159: Competitors of the Venturi Eclectic: GEM e4 and e2 with bicycles, Ligier electric and the Renault Twizy Z.E. concept.....	211
Figure 160: Design analysis of the Venturi Eclectic concept.....	212
Figure 161: Interior of the Venturi Eclectic concept.....	213
Figure 162: Venturi Volage concept (2008).....	215
Figure 163: Toyota logo.....	216
Figure 164: Toyota Prius (2009).....	216
Figure 165: Toyota's hybrid technology plate.....	218
Figure 166: Toyota Alessandro Volta concept (2004).....	219
Figure 167: Toyota FT-HS concept (2007).....	220
Figure 168: Iq electric concept (2009).....	220
Figure 169: Toyota I-REAL concept for individual mobility (2007).....	221
Figure 170: Toyota Fine T concept (2006).....	221
Figure 171: Toyota Hybrid X concept (2007).....	221
Figure 172: Toyota Highlander Hybrid (2007).....	222

Figure 173: Toyota Prius (first generation, 1997).....	223
Figure 174: Toyota Prius (second generation, 2004).....	224
Figure 175: Toyota Prius (third generation, 2009). ....	224
Figure 176: The new icon: Cameron Diaz, Gwyneth Paltrow and the cartoon dog Brian with their Prius. ....	226
Figure 177: Competitors of the Toyota Prius: Honda Insight (first and second generation), Honda Civic Hybrid, Chevrolet Volt, Ford Fusion Hybrid, Mercedes-Benz S400 Hybrid.....	227
Figure 178: Different approaches to hybrid powertrain (clockwise from the top): Toyota Synergy Drive, Lexus Hybrid Drive, GM Two-Mode, Honda Integrated Motor Assist.....	228
Figure 179: Design analyses of the second generation Prius. ....	229
Figure 180: The interior of the second generation Prius. ....	230
Figure 181: The interior of the third generation Prius. ....	230
Figure 182: Design analysis of the Toyota Hybrid-X concept.....	231
Figure 183: Design analysis of the third generation Prius.....	231
Figure 184: Toyota 1/X concept (2007).....	233
Figure 185: The Seedcar (2007). ....	235
Figure 186: Crystal Aerospace concept (2006). ....	239
Figure 187: Map developed from the results of Puchaski's research, <i>Feel the Future</i> (2009). ....	241
Figure 188: Project Chart - first part.....	243
Figure 189: Scene from Ridley Scott's film <i>Thelma &amp; Louise</i> (1991).....	245
Figure 190: Sketch of the Frisbee Blank Car (2009). ....	248
Figure 191: Sketch of the Frisbee Blank Car (2009). ....	249
Figure 192: Sketch of Frisbee Blank Cars parked in a street (2009). ....	249
Figure 193: Sketch of a Frisbee standing out in the row to be used (2009).....	250
Figure 194: Sketch of the impact of Frisbees on the city landscape (2009).....	250
Figure 195: Bio-resin model of the Frisbee Blank Car (2009).....	251
Figure 196: Bio-resin model of the Frisbee Blank Car (2009).....	251
Figure 197: Bio-resin model of the Frisbee Blank Car (2009).....	251
Figure 198: Hoxton Square, BedZED and The Boltons. ....	252
Figure 199: Presentation board for Hoxton Frisbee by Fernando Ocana Espinosa (2009).....	255
Figure 200: Presentation board of Hoxton Frisbee by Ido Baruchin (2009).....	255

Figure 201: Presentation board for BedZED's Frisbee by Juha-Pekka Rautio (2009).....	256
Figure 202: Presentation board for BedZED Frisbee by David Eburah (2009).....	256
Figure 203: Presentation board of BedZED Frisbee by Heikky Juvonen (2009).....	257
Figure 204: Presentation board for The Boltons Frisbee by Young-Seong Kim (2009).....	257
Figure 205: Investigative sketch of fluid lines (2008).....	261
Figure 206: Investigative sketch of marine animal shape (2008).....	261
Figure 207: Sketch of the Fluid (2008).....	261
Figure 208: Sketch of the Fluid (2008).....	262
Figure 209: Sketch of the Fluid, top view (2008).....	262
Figure 210: Sketch of the Fluid, front view (2008).....	262
Figure 211: Bio-resin model of the Fluid Sports Car (2008).....	264
Figure 212: Bio-resin model of the Fluid Sports Car (2008).....	264
Figure 213: Bio-resin model of the Fluid Sports Car (2008).....	264
Figure 214: Presentation board for the Fluid Sports Car by Julliana Cho (2009).....	267
Figure 215: Presentation board for the Fluid Sports Car by Murray Westwater (2009).....	267
Figure 216: Presentation board for the Fluid Sports car by Elizabeth Pinder (2009).....	268
Figure 217: Presentation board for the Fluid Sports Cars by James Brookes (2009).....	268
Figure 218: Presentation board for the Fluid Sports Car by James Harness (2009).....	269
Figure 219: Presentation board for the Fluid Sports Car by Hitesh Panchal (2009).....	269
Figure 220: Film stills from the TV commercial for the Citroen DS (Citroen,1963).....	270
Figure 221: Sketch of passengers interacting in the interior of the Core (2009).....	272
Figure 222: Sketch of the architecture of the Core (2009).....	273
Figure 223: Sketch of the Core Control Interface (2009).....	273
Figure 224: Model of the Core in wood (2009).....	274
Figure 225: Model of the Core in wood (2009).....	274
Figure 226: Presentation board for the Core by Rui Guo (2009).....	277
Figure 227: Presentation board for the Core by Shawn Deutchman (2009).....	278
Figure 228: Presentation board of the Core by Ian Kettle (2009).....	278
Figure 229: Presentation board for the Core by Richard Bone (2009).....	279

Figure 230: Presentation board for the Core by Adam Kerr Phillips (2009).....	279
Figure 231: Debate with Christopher Reitz (left), Design Director of Alfa Romeo (2009). .....	280
Figure 232: Stéphane Schwarz (left) evaluating the Paradigm Shift Project (2009). .....	281
Figure 233: Core by Adam Phillips (2009). .....	284
Figure 234: Fluid Sports Car by Murray Westwater (2009).....	284
Figure 235: Hoxton's Frisbee by Ido Baruchin (2009). .....	285
Figure 236: Fluid Sports Car initial concept (2008). .....	286
Figure 237: Frisbee by David Eburah (2009). .....	286
Figure 238: Project Chart - part two. ....	287

## List of Tables

Table 1: Changes in temperature, sea levels, and Northern Hemisphere snow cover (IPCC, 2007) .....	36
Table 2: Green house emissions per sector in 2004 (UNFCCC, 2008) .....	37
Table 3: Inhabitants per Vehicle – 1994 and 2003 (ANFAVEA, 2007) .....	38
Table 4: Economic Forecast to 2035 (Gott, 2008) .....	39
Table 5: Vehicle's Fleet, 2000 and 2005 (Gott, 2008) .....	40
Table 6: Equivalent Emissions During Use and Preparation of Final Energy (AVERE, 2008). .....	60
Table 7: Emissions from Different Engines (AVERE, 2008). .....	61
Table 8: Average Consumption of Conventional Cars and Electric Vehicles. (AVERE, 2008) .....	61
Table 9: Comparative table of life cycle analyses of the Prius and equivalent ICE cars, petrol and diesel (Toyota, 2007). .....	218
Table 10: Index of cars included in the Car Design Timeline.....	312



## Acronyms and Abbreviations

ANFAVEA	Associação Nacional dos Fabricantes de Veículos Automotores, Brazilian National Association of Motoring Industry.
ASR	Auto Shredder Residue
AVERE	European Association for Battery, Hybrid and Fuel Cell Electric Vehicles
BEV	Battery Electric Vehicle
DFD	Design For Disassembly
ELV	End of Life Vehicle
EV	Electric Vehicle
FC	Fuel Cell
HEV	Hybrid-electric Vehicle
ICE	Internal Combustion Engine
IPCC	Intergovernmental Panel on Climate Change
LCA	Life Cycle Analysis
NG	Natural Gas
PHEV	Plug-in Hybrid-electric Vehicle
SUV	Sport Utility Vehicle
UNFCCC	United Nations Framework Convention on Climate Change
WCED	World Commission on Environmental Development

## Acknowledgment

I would like to thank a number of people for making this research possible.

First I would like to thank my family for their love and encouragement .

I'm grateful to former professors at the University of Sao Paulo, Brazil, for granting me the spirit and foundation of the academic research.

I would like to thank my supervisors: Dr Paul Ewing, for his very inspirational and challenging guidance that transformed this research and my design thinking; and Professor Dale Harrow, for believing in and supporting the research from the very beginning.

Thanks to the Royal College of Art staff, specially Andrew Nahum, Brian Davey, Cathy Johns, Clive Birch, Harriet Edwards, Julian Reichman, Peter Stevens, Richard Windsor, Sam Livingstone, Stéphane Schwarz, Wanda Polanski and Xavier Pick.

A special thanks to all the students who kindly collaborated, with their amazing designs, on the Paradigm Shift Project; and to Christopher Reitz for his precious participation in the final debate.

At the same time, I would like to thank my RCA colleagues, Daria Cabaj, Emilia Serra, Joe Simpson, Jorge Lopes, Kleber Puchaski, Lino Vital, Louise Kiesling, Luke Hammer, Osmar Rodrigues, Sergio Loureiro and Sheila Clark, for their friendship and support.

Finally, I would like to thank the sponsors of this research, the Brazilian Government and the CAPES Foundation.

This thesis is dedicated to my beloved ones at home.

## Author's Declaration

1. During the period of registered study in which this thesis was prepared the author has not been registered for any other academic award or qualification.
2. The material included in this thesis has not been submitted wholly or in part for any academic award or qualification other than for which it is now submitted.

Artur Grisanti Mausbach

March 2010

# 1. Introduction

'Paradigm Shift: The Aesthetic of The Automobile in The Age of Sustainability' investigates, in its widest context, the relationship between the automobile, the environment and people's aesthetic experience, through the perspective of a future sustainable society. The findings of this investigation led to the development of design concepts based on the reinterpretation of the myths that drive people's love affair with the automobile. These designs refer to the way in which an attractive car design may evolve under the guidance of ecological principles. Moreover, they represent an effort to align design and engineering disciplines with the development of more sustainable solutions to individual mobility.

The research is structured into two main areas of investigation: sustainability and aesthetics. Both areas are examined in relation to the automobile. Starting from the study of environmental impacts, the effort which has been made to develop more sustainable technologies is the focus of a qualitative analysis. The study progresses from broad issues to increasingly detailed design considerations. Thus, the review observes the improvements in traditional paradigms, biofuels, solar and wind power, hybridization, battery electric and hydrogen-powered vehicles, as well as developments in aerodynamics and design concepts, with a direct influence on sustainability and aesthetics.

In order to understand the reflection of sustainability in the aesthetic of the automobile, it was necessary to develop an organized analysis of the language of car design. Thus, a historical study of trends and styles helped to recognize the particularities of the aesthetics of different ages. The reflective observation of the evolution of car design often highlighted its incompatibility with growing environmental concerns, resulting in a series of questions about how technology and aesthetics will encompass the needs of a sustainable society. The failures in the current paradigms also represent the end of era in car design. The undeniable relationship between form, function and content, object and context, has exposed the existence of a possible paradigm shift in the aesthetics of the automobile.

A revolution in design is necessary, to establish new and sustainable values and practices that must be informed by an aesthetic typology. Thus, the Paradigm Shift project challenges the traditional understanding of the functional and mythical facets of the automobile in order to reframe its aesthetics based on meaningful principles of sustainability. With respect for the many approaches to sustainable design observed in the

review, the project focuses on creative design, based both on concrete needs and abstract aspirations.

**Meaningful Aesthetics** | Sustainability is becoming an increasingly popular subject of discussion in social and academic environments. This comes principally as a consequence of environmental concerns about climate change and global warming, pollution, waste, re-use and recycling, and the use and conservation of materials and energy.

Besides the commonsense benefits of a cleaner environment, recent studies by governmental, non-governmental and inter-governmental organisations have proved scientifically that the consequences of the misuse of planetary resources are catastrophic, and the expected future scenarios are far from sustainable unless there are global changes in behaviour. Even if these studies are still under discussion, concern for the protection of the environment is a moral issue. This issue encompasses modifying both the way we consume products and services and also the way in which these are designed and produced.

Alastair Fuad-Luke (2002) believes that 'designers actually have more potential to slow environmental degradation than economists, politicians, businesses and even environmentalists. The power of designers is catalytic. Once a new, more environmental benign design penetrates markets its beneficial effects multiply'. As a language, a meaningful design communicates its principles.

To achieve its objectives, design implies the observation of a number of factors, including function, ergonomics, manufacturing, materials, socio-economic issues, aesthetics and environmental issues. The relative importance of these factors in the process is defined by the priorities of the project and driven by the designer. The aesthetics of an object might seem to be the priority for design, yet more often it is decided by a combination of all factors. The best examples have coherence between most of the aforementioned factors, and the aesthetics of the project represents the whole design concept. Thus products become manifestos of a wider design proposal.

The Modern movement is an example of this kind of process. In architecture and design, it proposed a completely transformational project. Changes in production and manufacture, socio-economic issues and functionalism were all integrated to the aesthetic of the object.

Two iconic masterpieces of Modernist architecture, Mies van der Rohe's German Pavilion at Barcelona (1929, figure 1) and Le Corbusier's Villa Savoye (1928-31), present all the

aspects of the renewal of architecture proposed by the Modern movement. The new aesthetic was achieved without the need to repeat traditional architectural forms that would obstruct the evolution of architecture. (Lupfer et al., 2006)



**Figure 1: Mies van der Rohe, German Pavilion, Barcelona (1929)**

Following the same principles, furniture designs developed by the same architects harmonized perfectly with the language of architecture, and had the same coherence. Like the buildings, these furniture designs have been perennially admired, and have become design icons, desired and not discarded. These icons promulgated Modernist ideas beyond the design concept and significantly influenced subsequent generations of designers. Clearly, the idea of a total design process gave these objects their meaning, and further, its significance gave them the status of an artwork.

The Modern movement, with its belief in industrialised society, Futurism, mass-production and consumerism, are themselves all symbols of the 20<sup>th</sup> century, and the automobile, the materialisation of its spirit. Nevertheless, from William Morris (Sudjic, 2008) to Jane Jacobs (1961), the impact of these changes on society, cities and culture have always been critiqued.

**Future Retrospectives and Sustainable Perspectives** | At the beginning of the 20<sup>th</sup> century, the impact of industrialization predicted the worst for the century. In fact, Chaplin's famous image of the robotic man on the assembly line (in his film *Modern Times*, 1936) or Fritz Lang's huge machine (in his film *Metropolis*, 1927, figure 2) didn't really dominate human life, as had been feared. Eventually, we were able to make machines smaller,

enabling them to work for us. Most of the heavy labour is now carried out by machine, and still we call the spare time we created 'unemployment'. It continues to be difficult for humans to share the benefits of our achievements in science and technology, what we might call sustainable development. On the other hand, we are sharing the worst impacts of development, and weaker nations carry the heaviest burden, being at the bottom of the capitalist pyramid.



**Figure 2: Fritz Lang, Metropolis (1927)**

The situation in a city context can be extended and identified at a global scale. The structure inherited from church, government or market-centred settlements is the basis of many cities. It determines mobility patterns, urban flow and the social barriers of the city. (Kostof, 1991)

Urban planning has played a major role in adapting the city to an up-to-date model of mobility. And no matter how important the achievements of public transport - underground trains, trams and buses - what really changed cities, more than anything in the past, was the car. The car was the starting point for designing a city in the 20<sup>th</sup> century.

The USA was the first country to develop car ownership widely, thanks to the revolution of Ford's mass-production. By 1927, the USA was producing 85% of the world's cars, and there was one car for every two American families (McCarty, 2007). Therefore, the USA was the first country to suffer the impact of this transformation, and it has grown to the dangerous point where today, North American cars alone, if the fleet was seen as a

nation, are at fifth place in the world ranking of carbon dioxide emissions. (Hickman, 2005)

The ever-growing volume of cars transformed North American city planning. In the 1920s, the new city was intended to be horizontal, turning the suburbs into the next ideal neighbourhood. New York's master builder, Robert Moses, built expressways to give access to beaches and suburbs.



**Figure 3: Robert Moses, Lower Manhattan Expressway, New York (1962)**

The suburb, together with these suburban and urban expressways, embraced the population increase in the post-war era. But in 1961, Moses' unstoppable bulldozers were halted by a book. Jane Jacobs' 'The Death and Life of Great American Cities' (Jacobs, 1961) critiqued simultaneously the garden city's paternalistic tedium, Le Corbusier's correct, magnificent and egocentric game, and the de-humanization of cities fragmented and divided into isolated areas by the expressway. Jane Jacobs suggested that high population densities, mixed land use, street interaction and people with different activities and time schedules all added to the enrichment of the city life. It was an opposition to the Modern movement.

Jacobs' ideas saved Greenwich Village from Moses' expressways (figure 3), and promoted throughout the USA an anti-Corbusian urban approach, based on the value of the organically-developed city, which is connected not to its geometry but to its metabolism and life cycle. The irony was that 20 years later, this process resulted in the gentrification of the city, which was made suitable for the upper classes, while public housing, which



often followed Corbusian models, was disgraced. Thus, the demolishing of the Pruitt-Igoe apartment blocks in Saint Louis in 1972 was considered the end of Modernism in architecture and urbanism. (Hall, 1988)

**Cars and pedestrians** | Modernist urban planning designed for an industrialized society, aiming for the dream of speed, and created cities to suit the most desirable industrial object: the car.

*"WE MUST BUILD ON A CLEAR SITE! The city of today is dying because it is not constructed geometrically. Statistics show us that business is conducted in the centre. This means that wide avenues must be driven through the centres of our towns. Therefore the existing centres must come down. To save itself every great city must rebuild its centre". (Le Corbusier, 1929)*

In the 1950s, when the Brazilian president Juscelino Kubitschek decided to build Brasilia (figure 4), the long-promised new capital in the countryside of Brazil, and move the seat of government from an increasingly chaotic Rio de Janeiro, Lucio Costa, a modernist Brazilian architect was commissioned to design it. Following Le Corbusier's ideas, Brasilia's streets were designed to enable vehicles to travel fast and without congestion, and were not made for pedestrians.



**Figure 4: Lucio Costa, Monumental Axle, Brasilia (1960)**

At the same time, Brazil was just beginning to experience the car at mass-production volumes. Juscelino Kubitschek was also the president who introduced the car industry to Brazil. Thus, Volkswagen started its production of the Brazilian Beetle in 1959. In the first

few decades, Brasilia was a city designed for the car, but there weren't many, and the people had to endure desert-like, warm and dry walking distances. The city completely lacked Jane Jacobs' animated street life.

The modernist utopia of creating a city by rational planning, instead of the organic development model, was questioned for decades while Brasilia was growing.

Unfortunately, the modernist city depends heavily on the car, and consequently relies nowadays on burning fuel. No matter whether this is bio-fuels or fossil fuels, this model has to be redesigned in the 21<sup>st</sup> century, for the sake of the environment.

The challenge of the 21<sup>st</sup> century is sustainable development – to ensure that we meet the needs of the present without compromising the ability of future generations to meet their own needs (WCED, 1987). In urban planning this can be translated into self-sustaining metabolisms and better-balanced urban spaces and opportunities. The city is a living organism on the planet, which consumes energy, resources and space, and produces heat, waste and pollution. The 21<sup>st</sup> century aspiration will be the zero-carbon city, which might also require a redesign of modes and habits of transportation.



**Figure 5: Norman Foster, Masdar (2006)**

The task of designing a zero-carbon city was taken on by the British architect Norman Foster in his project for Masdar City (figure 5), a key eco-development in the United Arab Emirates city of Abu Dhabi. To reach the planned zero-carbon and zero-waste targets, recycling polices were adopted, the use of cars was totally discontinued and sustainable

energy resources were mandatory, even for the construction process. Photovoltaic panels will also partially shade the streets, which are narrowed by the proximity of the buildings, creating a pedestrian environment appropriate to the extreme climatic conditions of the place. The master plan defines a maximum distance of 200 metres to the nearest transport link and amenities. A fully automatic electric personal transport system will provide an alternative to the private car, and a light railway will connect Masdar with Abu Dhabi's centre and the airport. (Masdar, 2008)

Being a suburb of Abu Dhabi, Masdar is a very particular development which does not follow the traditional metabolism of a city. The development seems to fit a business model, more than reflecting inclusive design. This doesn't make it unworthy as a solution for a more sustainable urban model, but it is not an ideal solution for every city – from what we know from the 20<sup>th</sup> century experience, this doesn't exist.

The notable difference between Masdar and Brasilia is the fact that the private car was banned completely, for the sake of the environment. As a living organism, the city's circulatory system is transport, and the car is part of its blood. A planned sustainable city without the car might function, but a sustainable car must be designed for the cities where it is needed.

**21st Century Challenges** | It is expected that by the middle of the 21<sup>st</sup> century, the number of internet users will reach almost the size of the world population. The vehicle's global market may stabilize (Andrews et al., 2002). The United Nations projects that the world population will reach almost 9 billion, and a significant majority of the increase will be in the urban environments of the less-developed countries. This figure is close to a 50% increase in the current world population figure, and may be the biggest challenge urban planning ever faces – if it is going to face it. Vehicle design must align to these concerns too.

To achieve sustainability, it will be necessary to use cleaner energy and transportation with a smaller environmental impact. A revolution in our concepts of mobility is thus mandatory. This would involve the use of private cars with zero CO<sub>2</sub> emissions, improved public transport systems for people and freight, public-private mixed transport modes, and the creation of streets suitable for pedestrians and cyclists. Without re-thinking the urban context as whole, and the cities as living cells on earth, it will be impossible to achieve sustainability.

Most cities have grown as an unintended assemblage of constructions, a collage of street textiles, where urban culture is negotiated in public spaces. The city is a very sensitive organism that requires a lot of attention in each intervention. The inclusion of diverse populations takes on special significance for its sustainable development. Nevertheless, most of the planning in the past lacked the ability to develop opportunities equitably. However, as the numbers of internet users start to match population numbers, it is expected that cities will develop with a more balanced spatial distribution, which will not abandon the old centres, but will help to create value throughout the city, and facilitate mobility. Contemporary communication and transportation networks already allow for greater urban dispersal; urban planning might help to decentralise high densities of activity and innovation.

In more developed countries, the infrastructure of public transport will definitely be renewed, also allowing the use of the private car. But the freedom of driving a car in a big city will be reduced by regulations associated with electronic traffic control and navigation.

There may be cities, neighbourhoods and mega-structures such as Masdar, which signify as special developments, where it will be possible to implement sustainable mobility systems easily. In existing city centres, light impact trams are more likely to mix with pedestrians, and the car will progressively be banned, as is already happening.

Everything indicates that Jacobs' hypothesis will continue to be true, because we want our existing cities to last and to be pleasant environments. We are capable of and willing to design so that we suffer less from the negative impact of our own development and growth, and to increase dialogues and positive interactions in our cities, thus aiming for a better quality of life and sustainability at the same time.

**Designing for People, Place, Production and Poetry** | As mobility solutions need to take account of the vehicle and the city, in order to achieve sustainability through design it is necessary to understand the context. Only by observing it is it possible to match user needs with industrial and environmental requirements. There is place, people and production, but also poetry. Sudjic (2008) points out that 'design is about the creation of anonymous mass-production objects, by people who spend a lot of time worrying about injection moulding, or about the precise degree of curve needed to blunt the sharp edges of a monitor screen. It is also about making objects that feel good to touch and to use'. Thus, a sustainable design has to be developed by also taking into account its aesthetics.

The literature review in this thesis studies both backgrounds. It starts by looking at the automobile and sustainability. Firstly, the research focuses on the investigation of sustainable solutions to automobile development, addresses the definition of sustainable development and sustainability, and reviews energy sources and materials and the car industry. A key factor in my accomplishment of this work was my participation in multidisciplinary conferences about mobility and sustainability. These include: *Challenges of Urban Mobility* organized by the Society of Automotive Engineers of Brazil (Sao Paulo, 2008); *CIANTEC International Conference of Art and New Technologies* at the Museum of Contemporary Art (Sao Paulo, 2007), and three editions of *EVER - Conference on Ecological Vehicle and Renewable Energies*, (Monaco, 2007-9).

In relation to the aim of my research, in 2009 I organized a section on vehicle design at the Monaco EVER Conference, which aimed to show the emerging language of sustainable design, outside designers' usual audience. Some of this work is presented in Chapter 5. I also organized the *City Mobility Sustainability Workshop* at the College of Architecture, Urbanism and Design of the University of Sao Paulo (Sao Paulo, 2007).

The second part of the literature review, entitled *The Automobile and Aesthetics*, focuses on the history of the automobile as an aesthetic experience. The historical study of aesthetics recognises, throughout the evolution of car design, many different trends and styles, and three ages, all explained in the second part of the literature review. The historical study in this chapter was developed in relation to the concept of the timeline presented at the opening of this thesis, and studies the epitomes of the Three Myths, within various chronological periods.

The Three Myths that have sustained our love affair with the automobile is an important concept within this research. This concept emerged from the historical study of the automobile and aesthetics, and is used as a pathway to the investigation of the design language of the past, present and future.

The Case Studies presented in Chapter 4 investigate today's ecological interpretation of the Three Myths. At the same time, the case studies looked at the current state of the art in terms of production cars, and questions the values and meanings of their credentials of sustainability. The Myth of Freedom is represented by the Smart Fortwo model, a rather ecological car that made its name by being a product of pop-culture. The Myth of Speed is represented by the study of the Venturi brand that produces electric vehicles for a very exclusive market and attempts to create references to car design based on principles of

sustainability. The Myth of Comfort is represented by the Toyota Prius, the most successful car on the market among those perceived to be ecological by the general public. Together, the literature review and case studies offer a broad examination of the past and present nature of automobile design in relation to aesthetics and sustainability.

The future of the sustainable automobile is then investigated in the project in Chapter 5. Firstly, the Three Myths are reinterpreted according to the expectations of a sustainable society. Then, to shed a light on the propositions, I developed interpretations of the Three Myths, through practice design work. Later, these design hypotheses were turned into a workshop theme and given to a group of Master's degree students to develop further. At the same time the three design themes tried to cover common functional and symbolic aspects of the automobiles. The Myth of Freedom is reinterpreted in the Frisbee Project, that also investigates the car as a mobility device for the city. The conciliation between the Myth of Speed and sustainability is explored through the Fluid Project, that also investigates the future of the sports car. The Myth of Comfort is taken to an extreme, through the design of autonomously-driven family saloons, in the Core Project.

The design concepts created were exhibited and discussed with specialist designers from industry and academia. The results of the project were evaluated, in the light of the research findings and adopted methodology, to validate the hypothesis of the research. The methods of enquiry and analysis were transparent, and systematically conducted. The evaluation is presented in the respective section of Chapter 5. Thus, the final outcome is an assessment of the future aesthetics of automobile in the age of sustainability.

The original contribution of this research is, therefore, as much a methodology for the evolution of car design in the age of sustainability as an original interpretation of this aesthetic, represented through a thesis and a series of design concepts, which covers the search for beauty and sustainability and a design for people, place, production and poetry.

## 2. Literature Review

**Introduction** | The literature review is structured into two main areas in regard to the objectives of this research: firstly, sustainability, and secondly, aesthetics. Both areas are studied in relation to the automobile.

Firstly, this study reviews the subject of sustainability. In aiming to clarify the relationship between the environment and the automobile, the first section covers a broad spectrum of technologies and design solutions, with many examples. This section also presents the concepts of sustainable development, sustainability, sustainable design, and eco-design. This section of the literature review observes the concerns about the impacts of mobility on the environment in accordance with both the forecasted growth in the numbers of vehicles on the road following current patterns of consumption and the prevailing methods of design and production. The review then focuses on the alternative solutions being investigated, both by the automobile industry and in academia. A qualitative analysis of these propositions is undertaken to create a reference guide to this project - and to designers in general - respecting, however, the holistic and multidisciplinary approach necessary for the definitive development of more sustainable solutions to auto-mobility. Moreover, the aim of this section is to understand the failures inherent in the current paradigms and the way in which new ones are being developed in the direction of sustainability.

Secondly, the aesthetics of the car is investigated in a historical context, observing styles, typologies, brand identity, iconic models and their meaning. This section presents the concepts of beauty, aesthetics, aesthetic experience, and the symbolism associated with the object that culminates in the creation of the myths of the automobile. An analysis is made by observing the production models that are also shown in the historical timeline presented at the beginning of this research. To give a broad picture of automobile aesthetics, the survey relating to this subject brought together three different approaches found in the literature. The first relates the history of the automobile chronologically to the evolution of technologies and the development of typologies, both mainly seen as consequence of paradigms of production and consumer demand. The second approach, based on aesthetic sensibilities, studies the characteristics of the design language through the observation of styling themes. As a consequence, this study primarily focuses on the post-war period - i.e. the study by Paolo Tumminelli (2004), that was used as the starting point for the creation of the timeline. The third approach, relating to the aesthetic

experience, is found in books by Bayley (2008), Glancey (2003) and Nahum (2009), and offers an appraisal of cars as cultural symbols, magical objects or icons of the last hundred or so years. In bringing the three together, the terminology included names from either style themes or typologies, reflecting their importance in defining a trend in car design.

The study is organized into three ages and within these many different design trends (all explained later in the research). The trends are named as they are commonly referenced in the current literature, with the original addition of a classification for the new concept cars, which were developed with the aim of a more ecological performance. The classification was created to help to create an understanding of the aesthetic properties of different designs and to be able to identify when and how the current aesthetic paradigms would be replaced. Moreover, the structure of the study indicates how the aesthetics of the automobile is approached in this research: on the one hand it covers contextual experiences and meanings; on the other, it encompasses the physicality of the architecture and styling which the designer manipulates to create the aesthetic properties of the automobile.



## 2.1. The Automobile and Sustainability

### 2.1.1. The impacts of mobility

The spectre of global warming has been raised concerning the impact of transport on the environment at an unprecedented pace. The first section of this literature review investigates the impact mobility has on climate and environment, and studies the relationship between consumption, global warming, habitat and human health.

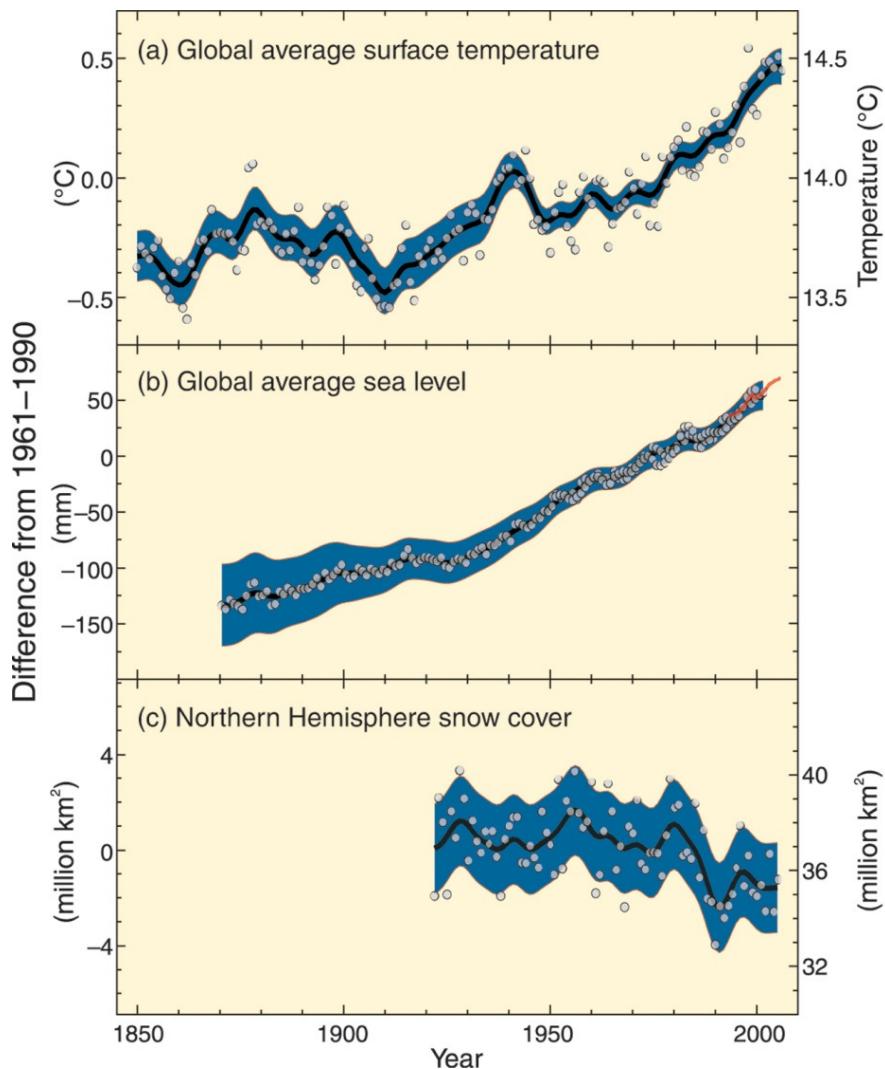
The Stern Review (2007) indicates that 'Climate change is a serious and urgent issue. The Earth's climate is rapidly changing, mainly as a result of increases in greenhouse gases caused by human activities'. Meanwhile, outside the scientific community the validity of global warming studies has been questioned. However, the former North American Vice-President, Al Gore (2006) points out that a University of California scientist, Dr. Naomi Oreskes, published in *Science* magazine a massive study of every peer-reviewed science journal article on global warming from the previous 10 years. Of the 928 articles published on climate change, none was in doubt as to the causes of global warming. But in the popular press, including *The New York Times*, *The Washington Post*, *The Los Angeles Times* and *The Wall Street Journal*, out of 636 articles 53% were in doubt as to the causes of global warming.

This research regards the background provided by the Intergovernmental Panel on Climate Change and the scientific community involved in it. The IPCC report published in Paris on 2 February 2007 is the second of the kind in this century. It is the first official text from the United Nations, and indicates a very likely level of certainty (90%) that the rise in the temperature of the Earth is provoked by human activity. The document states that 'warming of the climate system is unequivocal, as is now evident from observations of increases in global average air and ocean temperatures, widespread melting of snow and ice, and rising global average sea level'. The temperatures will increase between 1.1 to 6.4 degrees Celsius until the end of this century. (IPCC, 2007) (UNFCCC, 2008)

The IPCC (2007) defines Climate Change as 'a change in the state of the climate that can be identified (e.g. using statistical tests) by changes in the mean and/or the variability of its properties, and that persists for an extended period, typically decades or longer. It refers to any change in climate over time, whether due to natural variability or as a result of human activity.'

The observed warming of the system (Table 1) is called global warming. The IPCC (2007) concludes that 'many natural systems are being affected by regional climate changes, particularly temperature increases.'

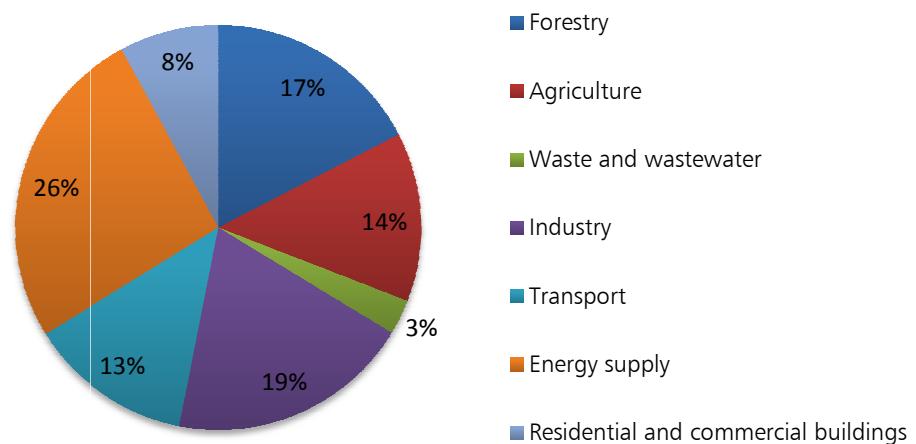
**Table 1: Changes in temperature, sea levels, and Northern Hemisphere snow cover (IPCC, 2007)**



Furthermore, the IPCC (2007) states that 'changes in the atmospheric concentrations of greenhouse gases and aerosols, land cover and solar radiation alter the energy balance of the climate system and are drivers of climate change. They affect the absorption, scattering and emission of radiation within the atmosphere and at the Earth's surface'. According to the report, 'human activities result in emissions of four long-lived greenhouse gases: CO<sub>2</sub>, methane (CH<sub>4</sub>), nitrous oxide (N<sub>2</sub>O) and halocarbons.' Global atmospheric concentration of the three first gases 'have increased markedly as a result of human activities since 1750 and now far exceed pre-industrial values determined from ice cores spanning many thousands of years'. The increases in CO<sub>2</sub> and CH<sub>4</sub> are strongly related to use of fossil fuels. (IPCC, 2007)

The non-governmental organization One Planet Living has calculated that personal transport accounts for 18% of the total CO<sub>2</sub> emissions of a British citizen, second only to the consumption of food, (24%) and the use of shared infrastructure (20%) (Desai and King, 2006). Global figures of green house gases emissions can be seen on table 2.

**Table 2: Green house emissions per sector in 2004 (UNFCCC, 2008)**



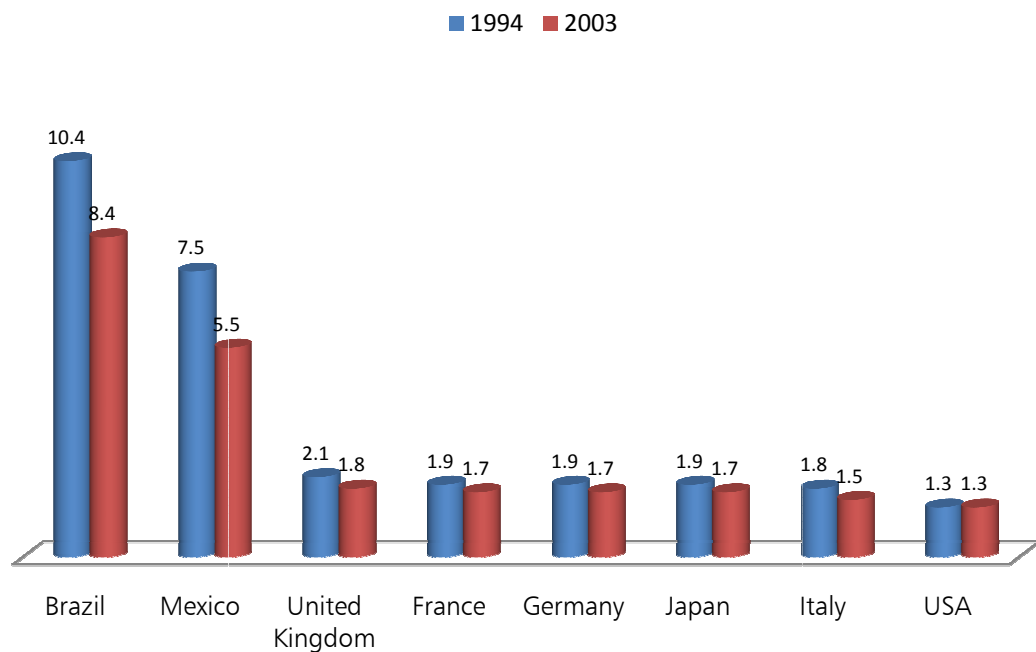
The current model of mobility is mainly based on road transport. The Stern Review (2007) reports that road transport accounts for 76% of the total CO<sub>2</sub> emissions of the transport sector in the world. In detail, cars and vans represent 45%; two and three wheeled vehicles, 2%; buses, 6%; freight trucks, 23%; rail transport accounts for 2%, water transport 10%, and air transport 12%.

According to Hickman (2005) 'for as long as we continue to rely on fossil fuels to move us from A to B, our unprecedented mobility will continue to have a profound impact on the environment'. The Union of Concerned Scientists states that 'the choice of vehicle you drive has a greater effect on the environment than any other choice you make as a consumer. They are one of the world's greatest sources of pollution, their presence blights much of our landscape, and they are responsible for thousands of deaths each year through accidents and air pollution. But as long as cars continue to give us a sense of freedom and mobility, their allure will remain irresistible.'(Hickman, 2005)

Thinking globally, the problem is not just about which car the consumer will buy, but also how many will be bought. Ekins (1992) uses the equation  $I=PCT$  to represent Impact on the environment (I) as a product of Population (P) X Consumption (C) X Technology (T). (Whitelegg, 1993)

Today there are an estimated 840 million vehicles in the world, for a population of 6,300 million. The average proportion of 7.5 inhabitants per vehicle does not represent an egalitarian distribution of the benefits of mobility, as shown in table 3. (ANFAVEA, 2007)

**Table 3: Inhabitants per Vehicle – 1994 and 2003 (ANFAVEA, 2007)**



Andrews, Nieuwenhuis and Ewing (2007) state that ‘mobility has contributed to and is a consequence of economic growth in industrialised countries, while in less developed countries it is viewed as a necessary requirement for sustaining economic growth and perceived as benefit of such growth’. Philip Gott (2008) observes that mechanized mobility has become essential for our modern way of life. There is a strong correlation between per capita income and the number of vehicles in use, as shown in figure 6. ‘Increasing wealth is accompanied by an increase in the motorization rate that begins in earnings at about \$5,000 per person and levels off in the range of \$35,000 per person, on a globally normalized basis of Purchasing Power Parity’<sup>(1)</sup>. (Gott, 2008)

---

<sup>1</sup> Purchase Power Parity (PPP) – meaning that the value of the Dollar is normalized such that in each country it has the same purchasing power (Gott, 2008)

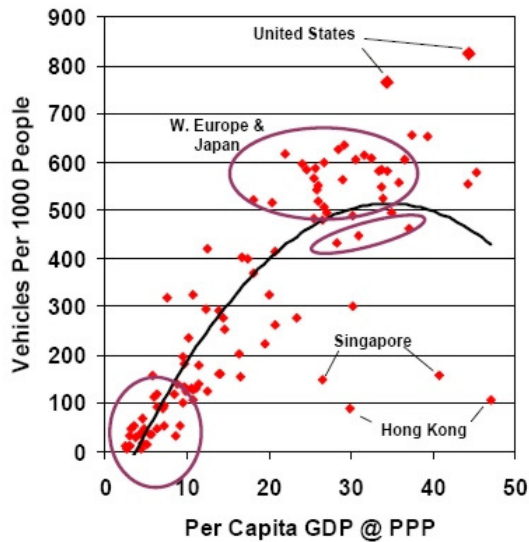


Figure 6: Per Capita GDP and Vehicles (Gott, 2008).

Gott (2008) states that economic forecasts anticipate increased prosperity in all regions of the world. 'These forecasts indicate that by 2035, national economies will grow such that every region of the world will have a per-capita GDP above \$5,000 at PPP', as shown in table 4. Once above \$5,000, it means the possibility of acquiring mobility. Taking into account the growth of the population until 2035, it is possible through this projection that vehicle numbers will quadruple, as shown in table 5.

Table 4: Economic Forecast to 2035 (Gott, 2008)

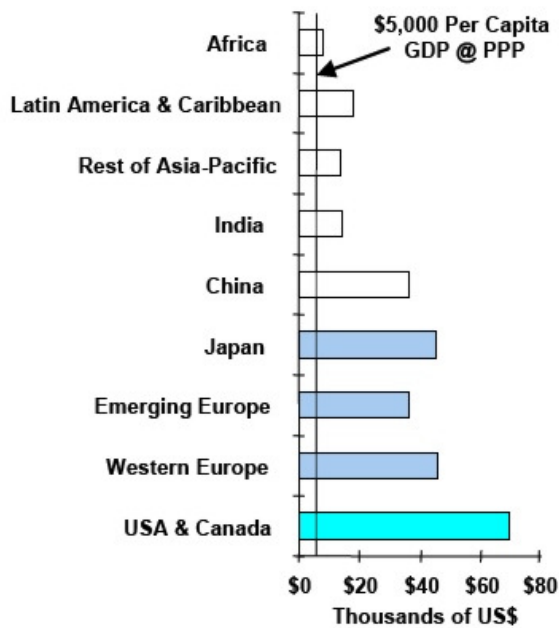
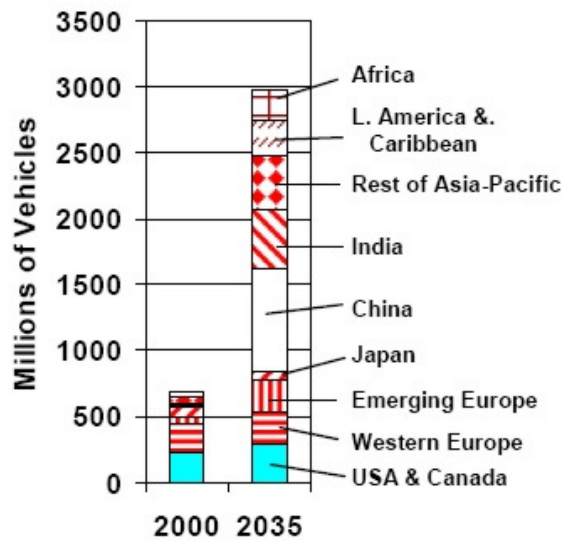


Table 5: Vehicle's Fleet, 2000 and 2005 (Gott, 2008)



If all countries follow the development model of the United States of America, which owns about one third of the world's vehicles, the consequences to the environment may be catastrophic. Today, the CO<sub>2</sub> emissions of cars in the USA alone could be listed, are the equivalent of a hypothetical fifth most polluting nation in the world, behind only the USA, China, Russia and Japan. (Hickman, 2005)

However, Hickman (2005) states that the effects of CO<sub>2</sub> emissions on climate change are not the only negative consequences of the current model of mobility. 'The list of problems is long and far-reaching: localised air pollution leading to health problems such as asthma; road-related fatalities and injuries; social exclusion caused by busy roads; noise pollution; the impact of road building on the wildlife and rural environments'. Car ownership itself accounts for numerous costs to society, as Whitelegg (1993) lists below:

- Individual costs
  - Ownership costs
  - Operating costs
- Direct costs
  - Highway and road expenditures
  - Interest on provincial debt due to previous highway spending
  - Government spending on the environment (pollution control and clean up)
  - Road safety
  - Health care

- Policing
- Court costs
- Subsidies to companies
- Hidden costs
  - Destruction of farmland, urban green space and habitats
  - Excessive energy costs from making and using the car, especially in areas of urban sprawl
  - Damage to air and water from mining
  - Air and soil pollution from drilling and processing petroleum
  - Air and soil pollution and contamination from smelting
  - Water pollution from the production of petroleum-based chemicals
  - Damage from the transport of petroleum on land and water
  - Acidification of land and water from car emissions and auto industry smokestacks
  - Damage to plant and crop growth from elevated levels of ozone
  - The growing environmental and health costs of global warming
  - Damage to air, land and water from the disposal of cars and their component parts
  - Damage to human health from regular discharge of toxic waste into lakes and rivers by auto industry
  - Respiratory damage from elevated levels of SO<sub>x</sub> and ozone
  - Neurological damage from elevated levels of lead
  - Damage to skin and eyes from ozone depletion
  - Loss of time due to overcrowded highways and roads
  - Stress and decline of quality of life
  - Financial costs due to lost productivity
  - Emotional damage to victims of accidents and families
- Opportunity costs of car dependence
  - Lack of research and development for rural and public transit and alternative fuel
  - Growing inflexibility of the economy

Whitelegg (1993) adds that 'there can be no understanding of sustainability at any other level than global'. Therefore, the social and environmental implications of current modes of production adopted by the industrialized economies have to be tackled.

David Harvey declared in an interview to the Danish Architecture Centre (2008) that 'competitive capitalist growth is the driving force behind many of the changes going around us. The social inequalities and discriminatory structures of gender, race and ethnicity, which this competitiveness brings about, are not conducive to sustainable practices. (...) The organization of production systems relates to the organization of social and technical divisions of labour as well as to technologies. This system is driven by a political economic system in which the coercive laws of competition and market valuations hold priority of place'. The designer Philippe Starck adds that 'the veneration of progress for its own sake has resulted in a world where things take precedence over people' (Datschefski , 2001).

Stuart Walker (2006) points out that 'a central tenet of industrial capitalism is growth, but nothing can grow forever, and we now seem to be reaching the limits of growth – at least in terms of the types of growth we have valued over the past century'. Walker (2006) considers that 'whatever one thinks about the continual growth model of today's capitalist economies, there is no doubt that technological development and product manufacturing have both positive and negative effects. (...) Resources are extracted from the earth, refined, formed into parts and assembled into products using mass-production processes; these products are then widely distributed, sold, used, discarded and replaced. This system, which has become increasingly automated over years, is mainly unidirectional in terms of flow of resources and energy. For most consumer products, post-use processing such as repair, refurbishment and redistribution, retrieval of materials and components, are economically marginal and relatively rare.' Moreover, Walker (2006) points out the 'to ignore the evidence around us of the consequences of our actions reveals a blindness to the circumstances, a lack of creativity and moral failing'.

Ezio Manzini (1992) uses the Greek myth of Prometheus (2) to explain the consequences of the negative use of men's capacity for utilising nature. His thesis is that the environmental problematic can generate a new sensuous horizon for design and can be

---

2 Greek myth of Prometheus: "Zeus in his wrath denied men the secret of fire. Prometheus felt sorry for his creations, and watched as they shivered in the cold winter's nights. He decided to give his most loved creation a great gift that was a "good servant and bad master". He took fire from the hearth of the gods by stealth and brought it to men in a hollow wand of fennel, or ferule that served him instead of a staff. He brought down the fire coal and gave it to man. As the introducer of fire and inventor of crafts, Prometheus was seen as the patron of human civilization. Uncertain sources claim he was worshiped in ancient Rome as well, along with other gods." (Wikipedia, 2009)



the source of vast series of cultural transformations and contemporary societal practices. More specifically, starting from inevitable discussions about the values of the industrial society, on which the emergence of the environmental problematic imposes, it will be possible not only to arrive at a system of consumer production more favourable to the environment but also to propose new values and deeper conceptions of quality.

The consequences of this process in terms of aesthetics are investigated later in this research. For design and business, changes in the systems also represent new opportunities and perspectives of sustainable development, as studied in the next section.

### 2.1.2. Crisis and Opportunity

In his book *An Inconvenient Truth*, Al Gore (2006) reminds that the Chinese expression for "crisis" consists of two characters side by side (figure 7). The first is the symbol for "danger", the second is the symbol for "opportunity". Gore (2006) adds that the 'Climate Crisis is, indeed, extremely dangerous. In fact it is a true planetary emergency'. And 'all the nations on Earth must work together to solve the crisis of Global Warming'. (Gore, 2006)



Figure 7: Chinese symbol for 'crisis'

Al Gore (2006) observes that the opportunities the crisis offers 'include not just new jobs and new profits, though there will be plenty of both', the understanding of the environmental issues leads to a wider understanding of global social issues. It is also the opportunity to build clean engines, harness the Sun and the wind, stop wasting energy and heating the planet (Gore, 2006). Thus, it is also an exceptional moment for the industry. The traditional paradigms of car design have encountered a unique moment for change.

In 1963, Colin Buchanan was already reflecting on the dichotomy of our affair with the automobile: 'We are nourishing a monster of great potential destructiveness. And yet we love him dearly. Regarded as the traffic problem the motor car is clearly a menace that can spoil our civilisation. But translated into terms of the particular vehicle that stands outside the door, we regard it as one of the most treasured possessions or dearest ambitions, an immense convenience, an expander of the dimensions of life, an instrument of

emancipation, a symbol of the modern age. To refuse to refuse to accept the challenge it presents would be an act of defeatism.' (Andrews, 2006)

Following the same direction, Victor Papanek (1984) states that 'the automobile provides an interesting case history: in nearly 100 years it has changed from useful tool to gas-guzzling status symbol and finally to a device the use of which pollutes the environment and destroys irreplaceable natural resources. It would be naive and dangerous to argue for the total elimination of the automobile. But what kind of car?'

Turning the crisis into opportunity is a design challenge. Papanek (1984) says that designers help to wield power to change, modify, eliminate, or evolve totally new patterns. New design concepts should encompass the advances in technology aiming for better environmental performance. The future of mobility is, according Evenden (2007), 'in the hands of those designers who seek for sustainable power, recycled materials and the freedom of all people to move when, where and how they wish'. Thus, the future of the automobile is not about renouncing benefits but transforming it into a sustainable process. For Stephen Newbury (2007), the opportunities for car designers are 'enormous: no longer will the shape of the vehicle have to be drawn around template of fixed 'hard-points' dictated by the standard position of the engine, transmission, and driveline', for example.

The following sections discuss the issue of sustainable development and the significance of its design, observing the current and future technology trends for sustainable cars which reflect the emerging aesthetic of sustainability.

### **2.1.3. Sustainable Development**

The most accepted definition of sustainable development is the one offered by the World Commission on the Environment and Development (1987): 'Sustainable Development is development that meets the needs of the present without compromising the ability of future generations to meet their own needs'. The commission also states that 'sustainability is based on physical and ethical concerns about equity that defines also that everyone (considering the future generations) has the same right of global space and resources'. (WCED, 1987)

Most people frequently use the terms *sustainable development* and *sustainability* interchangeably. Walker (2006) observes that, 'however, some authors have made a distinction between the two, arguing that sustainable development suggests an emphasis

on development and economic growth, whereas sustainability gives priority to the environment.' Walker therefore tends to use the term sustainable development to describe a broad process of development where economic, environmental and social concerns are considered simultaneously, and he uses the term sustainability to refer to ways of living in which these concerns are responsibly embraced and permeate our various endeavours. Therefore, as a projection of this context, the Paradigm Shift research discusses the future aesthetic of the automobile in the age of sustainability.

Walker (2006) also states that 'sustainable development can be understood as an important, but nevertheless limited, mythic story that attempts to give meaning to some of our principal modern-day uncertainties. (...) Like many previous myths and religious traditions, sustainable development aspires to an indefinable, unattainable goal – a goal which, nevertheless, many consider worth aiming for, but which forever eludes actual arrival. (...) If the question to ask the traditional myths is not 'Are they true?' but 'What do they mean?' then we must ask the same question of the evolving myth of sustainable development. It represents much more than simply an analytical approach to environmental auditing or improving business accountability. It also represents a way of acknowledging our values and beliefs and ascribing meaning to our activities.' Following this direction, Walker (2006) suggests that there are no definitive designs, merely steps along the way to sustainable design. Moreover, sustainability, also, 'not only implies diversity, it demands it, because sustainable approaches are so strongly associated with the specifics of place, region, climate and culture'.

Thus, this framework implies that it is necessary to look at the world with a wider view, what makes the achievement of sustainable development an interdisciplinary issue. It follows that sustainable design is the process of design that incorporates this holistic vision, aiming to preserve the Earth's natural resources, and dignity and the well-being of the people, in a global context.

#### **2.1.4. Sustainable Design**

The terms *eco-design*, *green design*, and *sustainable design* are also used most of the time without distinguishing between them. Manzini and Vezzoli (1998) explain that design based on ecological criteria is called eco-design. Nowadays, however, they argue it is known that improving current artificial systems and products is not enough to achieve environmental sustainability. Instead, it is necessary to think up new product designs, new

services and habits differently from before. Therefore, projects and activities that arise in such a conceptual framework are defined as *design for sustainability*.

According to Janis Birkeland (2002), the scope of 'eco-logical design (eco-design)' includes the following factors and objectives:

- Ecology and Economics: perceived as compatible; long-term -view.
- Design criteria: human and ecosystem health, ecological economics.
- Sensitivity to ecological context: responds to bioregion.
- Sensitivity to cultural context: respects and nurtures traditional knowledge of place and local materials and technologies; fosters commons, instead of building a homogeneous global culture.
- Works with whole systems, produces design that provide the greatest possible degree of internal integrity and coherence.
- Integrates multiple design disciplines and wide range of sciences, comprehensive.
- Redefines project goals around issues of basic needs, social equity, environmental justice and ecological sustainability

Fuad-Luke (2002) differentiates Green Design, Eco-design and Sustainable Design by levels of involvement. First, 'Green Design is a design process in which the focus is on assessing and dealing with environmental impacts of products rather than on the product's entire life. (...) Eco-design is a design process that considers the environmental impacts associated with a product throughout its entire life, from acquisition of raw materials through production, manufacturing and use to end of life. At same time as reducing environmental impacts, Eco-design seeks to improve aesthetic and functional aspects of the product with consideration to social and ethical needs'. Eco-design is, according to Fuad-Luke (2002), 'synonymous with the terms Design for Environment (DfE), often used by engineering design profession, and Lifecycle Design (LCD) in North America'. The last, Sustainable Design, 'is a design philosophy and practice in which products contribute to social and economic well-being, have negligible impacts on the environment and can be produced from a sustainable resource base. It embodies the practice of eco-design, with due attention to environmental, ethical and social factors, but also includes economic considerations and assessments of resources availability in relation to sustainable production.' (Fuad-Luke, 2002)

In the book *Design for the Real World*, Victor Papanek discusses the core of environmental design and its relation to habits of consumption. Papanek (1984) states that 'if design is

ecologically responsive, then it is also revolutionary'. He argues that design, to be ecologically responsible must not be built on the assumption that we must buy more, consume more, waste more, throw away more.'(Papanek, 1984)

Manzini and Vezzoli (1998) add to the discussion the understanding of the environmental issues and redirected social behaviour, starting from the demand for products and services which prompt the development of the products and services themselves. It follows that the redesign of current products and services might limit the development of more sustainable solutions, which should evolve on other levels, sometimes driven by the nature of the mythical goal of sustainable development. Therefore, Manzini and Vezzoli (1998) propose four levels of intervention which are similar to the differentiation between Green, Eco and Sustainable Designs proposed by Fuad-Luke.

- The ecological redesign of existing products and services: Considering the life-cycle of the product; improving global efficiency in terms of energy and resources consumption; enhancing recycling and reuse of materials and components.
- The creation of new products and services to replace current ones: Designing more ecological new products and services; working with this focus, more innovative technologies can be applied than by redesigning products.
- The creation of a new and sustainable mix of products and services: Offering a different and more sustainable way to achieve the benefits a product can give, through a new mix of products and services – must be committed to cultural change and new consumer behaviour.
- The proposal of new scenarios corresponding to more sustainable ways of living: Developing at a cultural level; promoting new standards of quality; changing the structure in response to demand.

Up till now, the automobile industry has mainly adopted the first level of intervention. The efforts made in that direction include, for example, hybrid electrical/petrol cars, aerodynamic developments, the use of plastic and lighter materials and biofuel engines. The second level of intervention is more difficult for the industry, due to the complexity of the infrastructure to produce and run cars. The Smart Fortwo (figure 8) is an example that might be closer to this level. There are a number of proposals of public city cars or car sharing systems, that fit the third level of intervention. The fourth level of intervention is mainly promoted by governments, focusing on solving traffic and pollution problems in cities – this sometimes places the government in opposition to the automobile industry.

The government, nevertheless, needs to protect the economy and the jobs created by the industry, which makes them possible partners in the development of sustainable mobility.



**Figure 8: Smart Fortwo (2008)**

Looking to the industry, Andrews, Nieuwenhuis and Ewing (2007) conclude that 'significant change in the automotive manufacture and use would create economic instability and is therefore unlikely.'

Academic research can work at the fourth level of intervention, offering an important contribution to the development of sustainable design. Walker (2006) points out that in the academic context, separated as it is from the pressures and pace of private sector practice, it is possible to reframe design with a more critical and artistic approach.

To reach more sustainable solutions, Manzini and Vezzoli (1998) state that design should be based on renewable resources; should make the best possible use of non-renewable resources (including water, air and land); must not return to the environment anything that cannot be re-incorporated into natural cycles; should respect other people's rights to environmental space and resources, encompassing all nations on Earth (Holmberg, 1995).

As sustainable design implies sensitivity to an ecological context (responding to bioregion; sensitivity to cultural context - respecting and nurturing traditional knowledge of place and local materials and technologies), it broadens the range of solutions. As sustainable design aims to give the best response to every problem, different car typologies may always exist, and all of them must be sustainable. This design philosophy works with whole systems, produces design that provides the greatest possible degree of internal integrity and coherence, integrating multiple design disciplines and a wide range of sciences.

**Industrial Ecology** | According to Manzini and Vezzoli (1998), the quality of a sustainable society depends also on the way the transition to it will happen; how the different social forces will behave, and how new cultures – and design - will emerge. Consequently, it is necessary to design for the context of the post-industrial society, megacities and also for natural habitats. This process is known as ‘industrial ecology’. It combines bio-cycles and techno-cycles, aiming to minimise and optimise the flux of matter and energy in artificial systems.

Bio-cycles, also known as bio-compatibility, is a common approach to sustainable design. It is based on the integration of human activities to natural cycles, reducing the impact on the environment - the ecological footprint (3) – ideally to zero, by using exclusively renewable resources. (Manzini and Vezzoli, 1998)

The use of techno-cycles, also known as non-interference, aims for the creation of production and consumption systems that work on a closed loop, re-using and recycling materials within artificial cycles, and autonomously from natural cycles. Nevertheless, it is impossible to have a completely independent cycle of non-interference, once always will be transformation of energy and production of entropy. Thus, the objective of techno-cycles is to minimize the exchange with natural cycles. Independently of the cycle, the greater the flux of matter in a system, the more difficult it will be to reduce its impact on the environment. (Manzini and Vezzoli, 1998)

To diminish these impacts, Manzini and Vezzoli (1998), propose the alternative of dematerialising the social demand for products and services. This can be achieved through the implementation of more intelligence in an existing system (e.g. the use of intelligent navigation control in cars, reducing the amount of transport), causing a reduction in material and energy consumption; or to the creation of new non-material products and services that replace previous versions (e.g. the internet).

---

3 An Ecological Footprint is, according to Fuad-Luke (2002), ‘a measure of the resource use by a population within a defined area of land, including imported resources’. The non-governmental organization Redefining Progress measures the ‘Ecological Footprint’, estimating the area of land and ocean required to support one person’s consumption of food, goods, services, housing and energy and assimilate their waste. One person’s ecological footprint is expressed in "global hectares" or "global acres", which are standardized units that take into account the differences in biological productivity of various ecosystems impacted on by personal consumption activities.

According to Manzini and Vezzoli (1998), the transition to sustainable development has already started, and it is necessary to manage it better to make the best use of the opportunities. The next sections address the efforts made by the automobile industry and government policies to develop more sustainable solutions to mobility, focusing particularly on the private car and the infrastructure to run it.

### **2.1.5. Life Cycle Analysis**

Considering the holistic approach that is necessary to reach sustainable design solutions, to make the automobile sustainable it is not enough to look at the product alone, but is necessary to analyse its whole life cycle, the infrastructure necessary to produce and run it, and the social and environmental implications of those processes.

According to Fuad-Luke (2002), 'Life Cycle Analysis or Life Cycle Assessment (LCA) is the process of analysing the environmental impact of a product from cradle to grave, in four major phases: production; transport/distribution/packing; usage; disposal or end of life.'

The Life Cycle Assessment is, according to Andrews, Nieuwenhuis and Ewing (2007), 'used to identify what improvements can be made to reduce the environmental impact of existing products or process and as a guide for the development of new products. Resources (materials and energy) use, human health, and ecological consequences are all considered in order to determine the extent to which a product is sustainable.' The Analysis involves the collection of data to produce and process an inventory. Nevertheless, while some products show positive results on a Life Cycle Analysis, that does not necessarily ensure social benefits, which may require a broader humanistic study. Therefore, in addition, a Life Cycle Analysis and Assessment includes evaluation of the inventory. (Andrews et al., 2007)

The acknowledgment of a product's life-cycle promotes a new sustainable design practice, termed Life Cycle Design. According to Manzini and Vezzoli (1998), the product must be designed taking into account every stage of its life cycle, and the ecological perspective should be integrated not only to its design, but also to its management and marketing.

Nowadays, however, Andrews, Nieuwenhuis and Ewing (2007) observe that the majority of cars are designed and manufactured according to the paradigms of Henry Ford (the



moving assembly line) and Edward Budd and Joe Ledwinka (the monocoque) (4). The production system may slow down the evolution of car design, and the emergence of more sustainable automobiles. 'In order to determine and develop the most sustainable automotive design and manufacturing paradigms, integration of a standard vehicle LCA system into the automotive design process is crucial, and the introduction of alternative fuel and powertrain technologies offers an opportunity to implement total rather than incremental changes' (Andrews et al., 2002). Nevertheless, the automobile industry is a powerful social actor, employing millions of people, either directly or indirectly, and changing its structures implies enormous social and economic impacts. As observed by Manzini and Vezzoli (1998), the process of change to a sustainable society needs to be undertaken carefully to achieve its objectives in an inclusive way.

Nieuwenhuis and Wells (Andrews et al., 2002) propose guidelines to analyse the environmental impact of the car's life-cycle. These include the following stages of the life of the product:

- Pre-assembly
  - Mineral extraction for raw materials (iron ore, bauxite, oil...)
  - Transport of raw materials
  - Production of secondary materials (steel, aluminium, plastics...)
  - Transport of secondary materials to assemblers and supplier
  - Production of components and subassemblies
  - Transport of components and subassemblies
- Assembly
  - Energy use in the assembly plant

---

4 The Budd Paradigm, in Andrews, Nieuwenhuis and Ewing (2007): 'Edward Budd and Joe Ledwinka patented in 1914 the all-steel body. The mass production of bodies was therefore a major breakthrough in the establishment of modern car mass production system. This technology became predominant in the industry because it facilitated the development of the unitary body, or the monocoque, and the consequent abandonment of chassis on which Ford relied. This design and manufacturing paradigm still dominates modern car design with the exception of those small-scale carmakers who never adopted 'Buddism'. To this day we have suffered the consequences of energy-inefficient and uneconomical design solutions. Moreover these solutions are contrary to the premise that all natural life forms minimise energy and material needs as a matter of survival.'

- Pollution caused in the assembly process, especially paint-shop emissions
- Release of waste materials into the ground and water and into the recycling system
- Transport of finished vehicles to the customer
- Use
  - Energy used for driving
  - Pollution caused by emissions and waste materials from disposables (batteries, tyres, oil...)
  - Land-use requirements (roads, fuel, parking facilities...)
  - Accidental damage to people and the environment
- Post-use
  - Transport to the dismantling site / scrap-yard
  - Energy used in the dismantling / scrapping process
  - Pollution caused by the dismantling / scrapping process

In the case of the automobile, the impacts of the first stage, Pre-assembly, tend to diminish. Recycling policies are progressively reducing the amount of raw material used in car production. The European Community End of Life Vehicles Directive regulates the disposal of cars and baselines for reuse and recycling. Figure 9 provides an overview of how ELVs arise and are treated in the European Union.

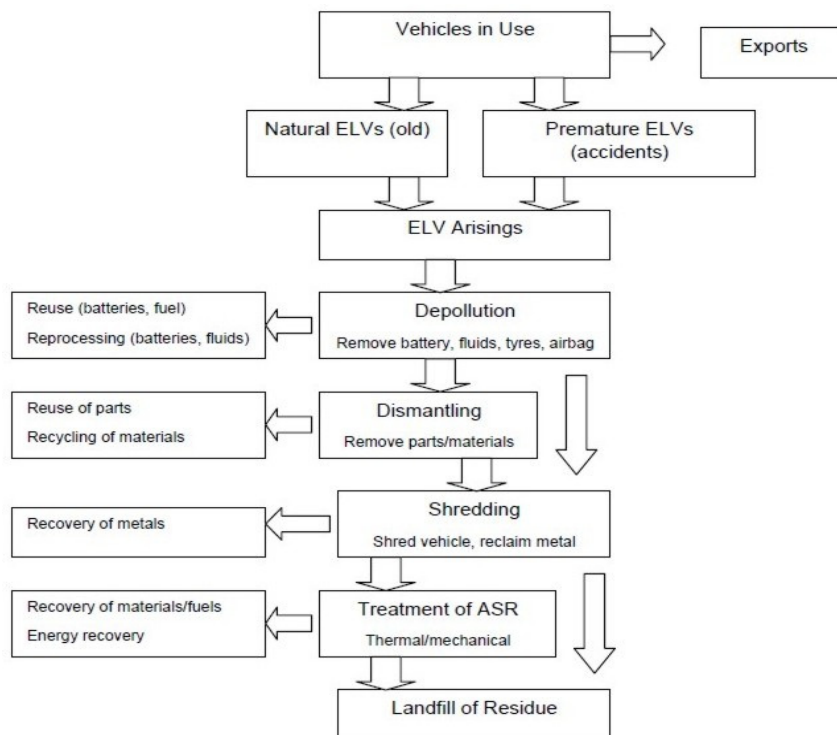


Figure 9: Description of ELV Arising and Treatment in Europe (GHK, 2006)

Andrews, Nieuwenhuis and Ewing (2007) observe that the materials on average 1998 car were:

- 68% ferrous metals
- 9% plastic
- 8% non-ferrous metals
- 3% tyres
- 3% glass
- 2% fluids
- 2% rubber
- 5% others

Where:

- 95 to 98% of metals are being recycled (ferrous and non-ferrous metals including aluminium, copper and magnesium).
- Plastics can be recycled, but 'one has to bear in mind that plastic's main appeal is how cheap it is to produce, and the recycled plastic has to compete with these low costs' (McCorquodale and Hanaor, 2006); and it deteriorates during recycling process. Thus recycling plastics only takes place in response to government directives. To deal with deterioration FIAT has created the Cascade recycling process: a structural component like a bumper has a second use as a non-structural component like ventilation ducting, and a third as a floor covering (Manzini and Vezzoli, 1998).
- Fluids are burnt as fuel in heavy power stations.
- 90% of batteries are recycled.
- Approximately 100,000 worn tyres are removed from vehicles every day in the UK, accounting for a total of 39.5 million tyres in 1998, 70% of which were recovered and reused; 30% were buried. The recycling of tyres includes: production of retread tyres, granulation for use in children's playgrounds, running track surfaces and as carpet underlay and landfill engineering projects such as motorway embankments and variety of marine applications.
- Glass can be recycled. Recycling saves about 50% of the energy required to produce virgin glass (McCorquodale and Hanaor, 2006). Nevertheless, the cost of removing the glass from the car is very high, especially for laminated glass, which needs to be removed manually (GHK, 2006). Once the materials used to produce glass are abundant and inexpensive, recycling is not prompted.

Andrews, Nieuwenhuis and Ewing (2007) observed that in the UK between approximately 74% of a vehicle is currently recycled (64% of materials are recycled and 10% of parts are reused). From January 2007, a minimum of 85% of the average weight of a vehicle must be reused or recovered. By 2015 the percentage has to increase to 95%.

The recycling process will also have an impact on countries with economies based on raw materials extraction and fuel and energy production, but it is a necessary process in the long term, and non-renewable resources need to be preserved. Andrews, Nieuwenhuis and Ewing (2007) note that the 'energy consumption during manufacture is between 6%-16% of total energy consumption during vehicle life. Thus, the impacts of fuel and energy consumption, in all stages of the life-cycle, are critical.

The urgency of global warming, and also the rising price of oil, encourage a significant moment of change in these paradigms. Furthermore, the search for more sustainable solutions also requires a high level of infrastructural changes, evolving another powerful social actor: the oil industry.

Oil is a finite resource and, although estimates vary about when the reserves will near exhaustion, many experts believe that this could be by 2050 (Andrews et al. 2007, Mackenzie, 1991). In 2000, transport consumed 74% of the total petroleum products in the UK, where 98% of its energy is used to move the vehicle itself and only 2% for the passengers. About 80% of the energy is lost as heat and exhaust (Andrews, Nieuwenhuis and Ewing, 2007). The losses and emissions through the exhaust are one of the worst impacts the automobile has on the environment, as pointed out before in this research. The Energy Saving Trust says that 59.9% of road transport CO<sub>2</sub> emissions come from passenger cars, 26.2% from heavy duty trucks and buses, 14.4% from light trucks, and 0.8% from others. As a result, individual mobility plays a decisive role in future ecological scenarios.

Whitelegg (1993) lists how CO<sub>2</sub> emissions from the transport sector can be reduced:

- Fuel economy
- Alternative fuels
- Reduce engine size and power
- Electric vehicles
- Transferring journeys to a mode which produces less CO<sub>2</sub>
- Land use and other changes to shorten journey length

- Substitution measures to allow journeys to be cancelled
- Speed limitation
- Traffic management and traffic calming
- Civilising the lorry and transferring freight from road to combined transport.

To reduce fuel consumption Whitelegg (1993) proposes development in:

- Mass/weight of vehicles and new materials to reduce weight
- Rolling resistance / tyre design
- Aerodynamic drag
- Matching of engine and transmission for economy
- Improved engine tuning

The next section shows how the automotive industry is dealing with some of these challenges and some examples of designs, on various levels of intervention, from reducing emissions and consumption on ICE cars, to solar-powered concept cars.

#### 2.1.6. Improving the traditional model

One simple and direct approach to sustainable design is to increase the efficiency of existing products, the previously mentioned First Level of Intervention (Manzini and Vezzoli, 1998). In the automotive industry, this might be represented by the improvement of the most traditional model of propulsion: the internal combustion engine using fossil fuels. Whilst the use of non-renewable resources can only be permitted in eco-design as a brief and temporary solution, nevertheless, the reduction in fuel consumption and noxious emissions is particularly important during the whole process of the adaptation of society and infrastructure to a more sustainable model.

**Mastering Engine Technology** | A particular effort to reduce fuel consumption has been taken by the BMW Group in a programme called BMW Efficient Dynamics. The BMW Group has claimed to have been focusing for years on the development of new models in relation to two aspects, considered by the company to be of equal significance: 'on the one hand the permanent, ongoing reduction of fuel consumption and emissions, on the other the consistent enhancement of Sheer Driving Pleasure. (...) The latest results of this development strategy show a significant reduction in the average fuel consumption and CO<sub>2</sub> emissions of all BMW Group vehicles sold in Europe in recent years: fleet consumption of all BMW Group cars in 2008 will be 25 per cent lower than in 1995. BMW Efficient

Dynamics is indeed a long-term strategy which rests on three pillars: In the short term the enhanced efficiency of petrol and diesel engines as well as their ancillary units, aerodynamics and energy management.’ BMW proposes, ‘in the medium term, additional advantages in fuel economy such as ongoing electrification of the drivetrain all the way to full hybrid technology which will provide further benefits and improvements.’ And in the long term the option of using hydrogen recovered from regenerative sources in the combustion engine. (BMW, 2008)

In terms of reduction of CO<sub>2</sub> emissions, Efficient Dynamics has already placed 21 BMW models under the level of 140 grams per kilometre. ‘In the compact segment, for example, the BMW 118d (figure 10) achieves exemplary fuel economy of just 4.5 litres per 100 kilometres in the EU test cycle (equal to 62.8 mpg imp) and CO<sub>2</sub> rating of just 119 grams/kilometre. But at the same time the 105 kW/143 hp four-cylinder diesel ensures acceleration from 0-100 km in just 9.0 seconds. Fuel consumption of a current BMW 525i is 33 per cent below the fuel consumption of the same model back in 1982 – and at the same time the quality of the car’s emissions has been improved approximately 95 per cent, while engine power of the BMW 525i, again in the same period, is up 45 per cent.’ (BMW, 2008)



**Figure 10: BMW 118d (2008).**

In addition, Brake Energy Regeneration and the Auto Start Stop function have been implemented in series production across the BMW Group's whole fleet, which also includes the Rolls Royce and Mini lines (BMW, 2009). BMW (2008) observes that ‘pursuing the policy of BMW Efficient Dynamics as the decisive factor in development, in efficient production using minimum resources, and in maintaining high social standards for employees at all plants and locations, the BMW Group has also strengthened its outstanding position in the current Dow Jones Sustainability Index – ‘for the third year in a row lauded as ‘the most sustainable car maker in the world’.

**Reducing Weight** | BMW has achieved significant reductions in weight by the introduction of the all-aluminium crankcase for the internal combustion engine in 1994, and magnesium/aluminium composite, in 2004 (BMW, 2008). Saving weight is an important issue in reducing fuel consumption, and can also benefit production, distribution, discarding and recycling processes by the selection of lighter and renewable materials. Historically, a lot of effort in this direction started after the 1973 oil crisis.

Crises have proved to be excellent opportunities for the development of smart design solutions to auto-mobility. Since World War II, Europe has seen the emergence of rational small cars, while North American cars continue to grow bigger and gain weight. Later, the oil crisis of 1973 had broader consequences and stimulated the development of lighter weight designs, and research into other materials, particularly plastics. Andrews, Nieuwenhuis and Ewing (2005) observe that 'since the 1990s manufacturers have sought to reduce weight in order to improve fuel economy and reduce in-use vehicle emissions. Use of plastics has subsequently increased and plastic have replaced some steel components, many of which are found in car interiors.'

**Cleaning up the Production Processes** | Apart from reducing weight, the use of plastics can also diminish the costs and environmental impacts of painting process, both considerably high. 'Until recently, automotive paints consisted of between 12% and 30% solids suspended in solvents such as xylene and toluene, which are produced during refining of crude oil. These solvents carry the solid component of the paint to the metal surface during spray application and as the paint dries, they evaporate and enter the atmosphere as volatile organic compounds (VOCs). Released in this way VOCs constitute the largest single source of air pollution generated in an automobile manufacturing plant, and produce carcinogens, mutagens and reprotoxic substances. As they break up in the sunlight they also form some of the ingredients of acid rain, while waste paint enters the water system as sludge. A European Commission directive was drawn up during the 1990s, proposing a 66% reduction in VOC emissions from industries using solvents by 2007. All paint and automobile manufacturers have thus been forced to find alternative solutions. (...) Although the use of plastics can eliminate the use of paint, many manufactures adhere to and are expected to continue to conform to the parameters set for steel under the Budd paradigm and therefore to paint the most immediately visible plastic components, namely those used on vehicle exteriors. (...) The paint plant is the most expensive part of the automotive plant. (...) Consequently, after the recent investment in and development of new paint plants following the introduction of

European legislation, manufacturers will not be prepared to abandon this technology. (Andrews, Nieuwenhuis and Ewing, 2005)

To make the painting process and the whole of car manufacturing more sustainable involves a challenging and costly process of change. Nevertheless, many of the challenges the automotive industry has to face, like reducing emissions, waste, energy and material consumption through manufacturing, are common to all industries. The scale of the impact of the automotive industry is, indeed, very significant, not only in absolute numbers but also in creating brand image. Conscious of this, industries like BMW are working to clean up the production processes and use fewer resources. One example is the BMW plant in Steyr, Austria, which generates no waste water. 'A closed water cycle and a complex filter systems ensure not a single drop is wasted, allowing the wastewater gully to be closed off. The plant saves up to 30 million litres of water annually.' (BMW, 2009)

Through a more holistic approach, the BMW plant in Leipzig (figure 11), Germany, which has a central building designed by the architect Zaha Hadid, bases its conception on Ford's production line (Hadid, 2006), but it is an open and humanized space, demonstrating neatness and cleanliness, and promoting social respect and integration to workers at all levels. The production line is actually situated across the central building.



Figure 11: Zaha Hadid BWM Central Building, Leipzig (2005)



### 2.1.7. Energy and engines

Renewing production structures is not easy. Modifying the infrastructure for car use, especially in terms of focusing on more sustainable sources of energy, may be even more difficult. According to Jan Olaf Willums (2008), from the Norwegian electric car manufacturer Think, the power sector is a key player in the future of automobile.

Kloess, Ajanovic and Haas (2008), show in figure 11 the many options for energy resources and corresponding engines. The renewable resources are reckoned to be more sustainable. In this group are electricity generated by hydropower, solar power and wind power stations and biofuels.

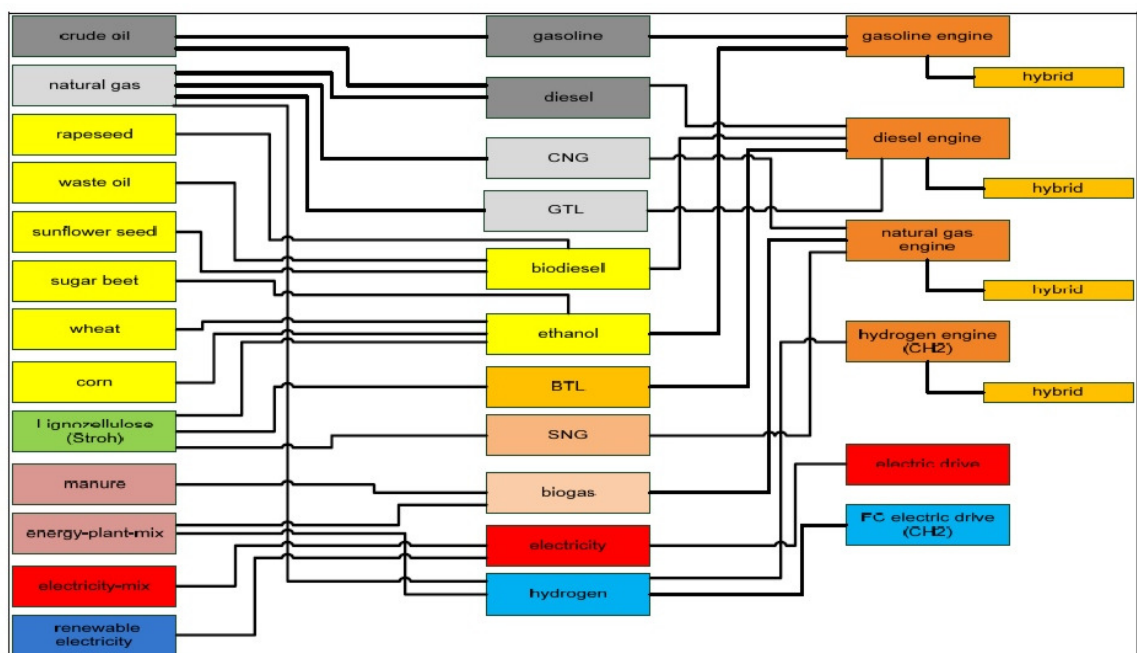


Figure 12: Resources, Fuels and Engines (Kloess et al. 2008).

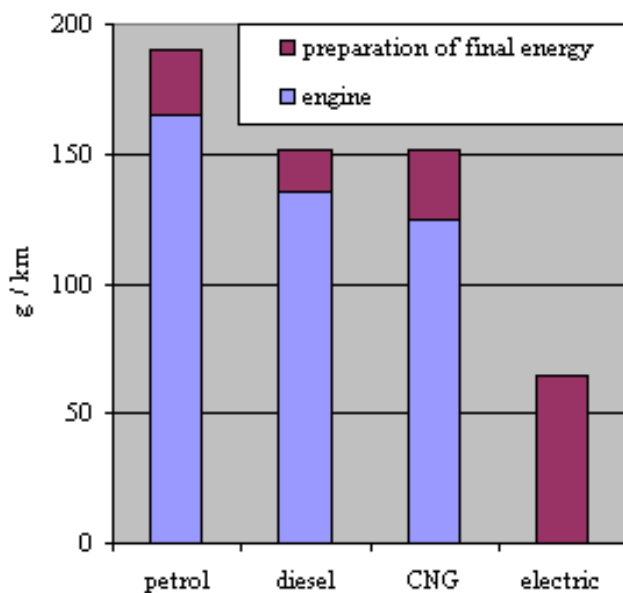
The emissions from hydropower stations have been studied in Brazil as part of the Kyoto Protocol agreement. Kemenes, Forsberg and Melack (2008) observe that the lakes created for hydropower stations flooded large areas of land vegetation. Under the water, the decomposition of this vegetation generates CO<sub>2</sub> and CH<sub>4</sub>, which are released in the atmosphere over a number of years. Part of the gases is released through the surface of the lake, and part is released under the surface, through the turbines, and a third part is released in the river after it has passed through the reservoir. Vincent Saint Louis (2000) affirms that the emission from these lakes represent, respectively, 4% and 18% of the global emissions of CO<sub>2</sub> and CH<sub>4</sub> from human activities. The statistics on the emissions after and under the reservoir have not been studied sufficiently yet.

Kemenes, Forsberg and Melack (2008) add that the problem is worse when the energy generation potential of the hydropower station (Flooded Area/Megawatts Generated) is low. To calculate the contribution of these emissions to global warming, CH<sub>4</sub> has to be converted into a CO<sub>2</sub> equivalent, being multiplied by 25. Nevertheless, CH<sub>4</sub> can also generate energy if technologies are developed to capture the gases. Kemenes, Forsberg and Melack anticipate that this might improve the energy generation potential up to 75% and might reduce its emissions by 65%.

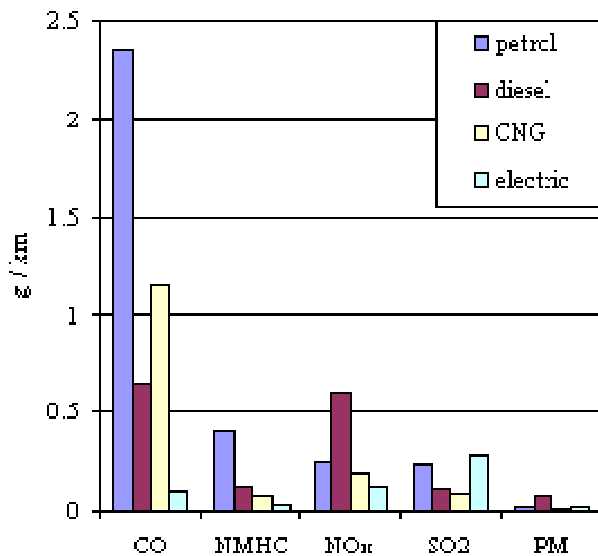
According to the first study on emissions from Brazilian hydropower stations (Rosa, 2006) hydropower was cleaner than that produced by a thermo power station, running on fossil fuels. However, study by Kemenes, Forsberg and Melack (2008) confirms that some Amazonian hydropower stations, due to particularities of the geography and flora, contribute to global warming more than thermo power stations, and are a threat to the rich local biodiversity.

Nevertheless, electricity has the advantage of not producing emissions during vehicle use, only doing so during the preparation of final energy, as shown in table 6 and 7 (AVERE, 2008).

**Table 6: Equivalent Emissions During Use and Preparation of Final Energy (AVERE, 2008).**



**Table 7: Emissions from Different Engines (AVERE, 2008).**



Pietro Menga’s evaluation also emphasises the importance of biofuel. According to Menga, in the case of automobiles (2008) ‘the most effective solutions are by far those constituted by BEVs and sugar-cane E-85 ICE vehicles. However all biofuel-based options have the other drawbacks’. The most important result is, observes Menga, the clear evidence that the presence of electric propulsion in the vehicle powertrain is always beneficial: ‘Although the maximum effectiveness is obtained with purely electric vehicles (BEVs), electrification also improves markedly conventional vehicles markedly, either in the mild hybrid electric form (HEV), or better, in the plug-in hybrid electric form (PHEVs).’

AVERE studies (2008) show that, ‘all figures being equivalent, taking into account the energy efficiency at both production and distribution level, the consumption figures are as follows:

**Table 8: Average Consumption of Conventional Cars and Electric Vehicles. (AVERE, 2008)**

	conventional cars		electric vehicles
	fuel consumption /100km	electricity equivalent	electricity consumption
car	8,5 L gasoline	909 Wh / km	488 Wh / km
van	12 L gasoline	1283 Wh / km	600 Wh / km
small lorry	16 L diesel	1910 Wh / km	1000 Wh / km

These figures show that electric cars, vans or small lorries, respectively consume 54%, 47% and 52% of the primary energy needed by internal combustion vehicles. It is clear that electric vehicles are much more energy-efficient. This advantage will increase when it will be possible to recharge vehicles by connecting them directly to electricity production sources with a total output efficiency exceeding 50% (plants with combined gas/steam cycle, fuel cells, buffer batteries, etc.).'

Menga (2008) maintains that diesel cars appear not to be very effective in terms of environmental sustainability, since the same environmental benefit obtained by using an electric car instead of a reference vehicles is obtained replacing as many as 3 cars with diesel hybrid, while use of non-hybrid (EURO 5) diesel is totally ineffective. And Whitelegg (1993) adds that a 'switch to diesel engines would seem to offer some benefits for reducing emissions of CO<sub>2</sub> but these would have to be set against what is known about carcinogenic emissions of particulates from diesel engines and the sulphur dioxide they produce.' Diesel can also be replaced, with additional benefits, by biodiesel.

### **2.1.8. Biofuel**

Biofuel is defined as solid, liquid or gaseous fuel obtained from relatively recently dead or living biological material, plants and plant-derived materials. The name is used to differentiate it from fossil fuels, which are based on long-dead biological material. Biodiesel and ethanol are the most commonly used types of biofuel, the fuels derived from biomass.

Biodiesel is processed from oilseed rape or recycled from used vegetable oil. Although it produces CO<sub>2</sub> and other emissions when combusted, it is also described as a 'clean fuel' because it is argued that the crops grown for fuel production act as a carbon sinks and absorb CO<sub>2</sub>. (Andrews, Nieuwenhuis and Ewing, 2007)

First-generation bioethanol is traditionally derived from a wide variety of sugar- and starch-rich crops, including grain, corn, sugar cane, and sugar beet. A new, second-generation production process currently in development will extract bioethanol from materials that contain lignocellulose, a strengthening substance found in woody plant tissues such as straw, cornstalks, wood chippings, or other organic materials that are often available as waste. (Saab, 2008)

In a global context, bioethanol is most popular in Brazil and the United States. In the 1970s, the Brazilian government developed a pioneering programme called Pro-Alcool, to

survive the global oil crises and secure the country's economy. 'The comprehensive programme included state support for distillery construction, tax incentives for bioethanol-powered cars, and a massive expansion of the ethanol fuel pump network. As a result, in the early 1980s when the rest of the world suffered under the highest real oil prices ever, almost all cars sold in Brazil ran on bioethanol'. (Saab, 2008)

FIAT, Volkswagen, Chevrolet, Chrysler and Ford developed bioethanol engines. Later, at the turn of the century, bioethanol had another important moment in Brazil with the introduction of flex-fuel engines, which in 2007 accounted for 83% of the domestic market. It is expected that by 2013, 52% of the Brazilian fleet will be of flex-fuel cars (15 of the 29 million) (ANFAVEA, 2007). Nowadays, Honda, Toyota, Peugeot and Renault also produce flex-fuel models in Brazil and some manufacturers are bringing this technology to Europe.

As one manufacturer selling bioethanol in Europe, Saab (2008) argues that 'the key environmental benefit of bioethanol is that, unlike petroleum, its consumption does not significantly raise atmospheric levels of CO<sub>2</sub>, which some scientific research suggests is a major contributor to global warming. This is because the CO<sub>2</sub> which is released during the burning of the fuel is counter-balanced by that which is removed from the environment by photosynthesis when growing crops and trees for ethanol production. This, in effect, stabilises the atmospheric CO<sub>2</sub>.' Saab's BioPower line includes the convertible 93, shown in figure 13.



**Figure 13: Saab 93 Convertible BioPower (2008).**

According to Menga (2008) the improvement in CO<sub>2</sub> emissions of bioethanol (E85) can reach 70%, compared with those from petrol. This is the same level of improvement achieved by battery-electric vehicles in Europe. Biofuel vehicles might be very interesting if they replace the fossil fuel fleet, because they might use the fuel in a natural cycle and the

released CO<sub>2</sub> would be partially absorbed. However, if it is considered that the pre-existing crops or vegetation were already absorbing CO<sub>2</sub>, it would be necessary to add an extra area of plantation for every new car produced. Thus, the common statement in defence of biofuels, supported by the capture of CO<sub>2</sub>, cannot be considered to be true once the monoculture is only replacing pre-existing forests or crops. Concerns about the impacts of biofuel production on agriculture and the environment also considers that while stimulating monoculture and forest devastation, it might affect biodiversity and compromise the production of food (e.g.).

Whitelegg (1993) reiterates that 'there can be no understanding of sustainability at any other level than global. (...) Presumably, Europe could move towards sustainability based on the conversion of vehicles to biomass fuel (e.g. ethanol, methanol) supplied from Africa and South America. This would deliver some of the gains to be had from sustainability, for example cleaning up urban air quality, but it would do little for the source countries denied adequate land for food crops and forced back into the kind of survival behaviour which currently destroys fragile environments through overexploitation of forest or marginal agricultural land. Poverty in the South is inextricably linked to the consumerist strategy of the North.'

The impacts of bioethanol made from sugar cane are lower than that made from corn, which requires two and a half times more land to produce the same amount of fuel. Saab (2008) also maintains that 'the vast majority of sugar plantations in Brazil are located near São Paulo, in the south of Brazil, thousands of miles away from the rainforest. Indeed, sugar cane grows best in dry, arid areas, so there is no risk of deforestation to make way for new sugar cane plantations as the bioethanol industry expands.' Nevertheless, the fact that the crops are grown near São Paulo is due to the proximity of the market, and to reduce transport costs, not only because of soil conditions.

Franca (2008) points out that the production of bioethanol in Brazil creates 20 times more jobs per litre of fuel than petrol. However, the working conditions are very poor and the salaries very low. Rodrigues (2009) concludes that 'looking at the sugar business in Brazil, it is evident that over the last 20 years the country has spent £2.5 billion on incentives, subsidies and technology in tackling oil dependency by producing ethanol (biofuel) from sugar cane. Since then, the sugar cane business has grown, allowing the country to save ten times the investment figure in oil imports alone, becoming the most important business in Brazilian agriculture. Putting aside the questions around the inconvenience of a

mono-culture, this business has created more than one million jobs, and most importantly reduced dramatically the level of CO<sub>2</sub> emissions in Brazil.'

### 2.1.9. Hybridization

Another way to reduce CO<sub>2</sub> emissions is the hybridization of the internal combustion engine with the addition of an electric motor. This may enable to provide zero-emission when running at very low speeds, and to assist the main engine during hard acceleration. The electric motor is driven by batteries charged both by the petrol engine and through regenerative braking, which restores the energy that is usually lost. 'A hybrid is particularly good around town, both in terms of fuel economy and emission generation, having the potential to generate no emissions at all. On motorways, however the hybrid powertrain contributes almost nothing; indeed the extra weight of the motor and batteries will actually harm fuel consumption slightly.' (Clean Green Cars, 2008)

Working together, the internal combustion engine and electric motor may double the fuel efficiency compared with a conventional vehicle (AVERE, 2008). According to the statistics produced by Clean Green Cars' research (2008), hybrids actually show an improvement of 30% in fuel consumption.

There are basically, four possibilities of hybridization (figure 14) :

Series hybrid system: Designed to extend the range of EVs on a single charge. The internal combustion engine is solely used to generate electricity.

Parallel hybrid system: Designed to increase fuel efficiency of ICE and to decrease exhaust emissions. The engine provides main propulsion, and the generator works in parallel to assist the engine to drive.

Series-Parallel hybrid system: Combination of series and parallel hybrid systems. The vehicle is powered by both ICE and a motor either independently or jointly.

Plug-in Hybrid Electric vehicles: Are a kind of combination between pure electric cars and hybrids. They have in fact a connection to the power grid, allowing overnight charging as well as a larger battery enabling the vehicle to run entirely on electricity for a long distance, for example in a city centre. Plug-in Hybrid Electric vehicles will make the bridge between pure electric cars and hybrid "traditional" vehicles. (AVERE, 2008)

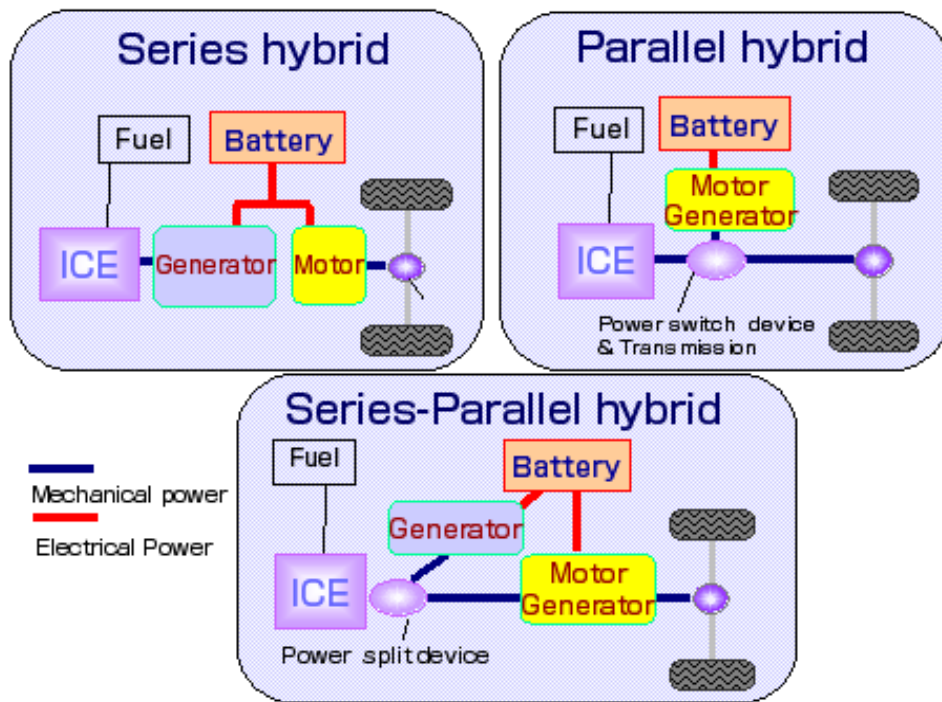


Figure 14: The Three Basic Kinds of Hybridization (AVERE, 2008).

Many car manufactures are developing hybrid powertrains and launching hybrid vehicles. These include Toyota, Honda, Nissan, Mazda, Mercedes-Benz, Ford and GM. The best-selling hybrid car is the Toyota Prius (figure 15), which has also the lowest CO<sub>2</sub> emission of the group, 104g/Km. According to Toyota, the Prius shows advantages over the whole life cycle, being consistently more sustainable than conventional equivalent-size cars. (Toyota, 2007)



Figure 15: Toyota Prius (2004)

**History** | Back in 1902, Ferdinand Porsche designed the first car in the world with an ICE to generate energy and electric motors installed on the wheels, for the Austrian company



Jacob Lohner & Co. The hybrid car was thus invented (Sharp, 2008). In 1905, H. Piper, a North American engineer, registered a patent for a hybrid vehicle with an electric motor that augmented power. 'Some hybrid cars were invented around this time with similar objectives in mind, including the first commercial production of a hybrid car in France in 1909.(...) Experimentation with hybrid technology continued for a while, until it died around 1920.' (Hasegawa, 2008)

In the 1970s, the Clean Air Act and the oil crisis renewed the interest in hybrid and electric cars in the USA. 'Automakers came out with alternative propulsion prototypes, including a parallel hybrid taxi by VW, and a parallel hybrid truck by Japanese automaker Daihatsu. But once gasoline became plentiful again, the hybrid fervour quickly dissipated. (Hasegawa, 2008)

Later, in 1993, the North American president Bill Clinton launched the Partnership for a New Generation of Vehicles consortium, 'a cooperative research program between the US government and major automobile corporations, aimed at establishing US leadership in the development of affordable, extremely fuel-efficient, and low-emission vehicles that could meet driver needs (Hasegawa, 2008). 'The big surprise was Toyota's request to join the party. When that appeal was denied, chairman Eiji Toyoda encouraged the creation of a task force in Japan called G21 - a global car for the twenty-first century' (Sherman, 2009). The group eventually developed the Toyota Prius - the subject of a Case Study in chapter 4 - launched in 1997.

Hasegawa (2008) declares that 'hybrid cars combining engine and electric motors have been proposed in different configurations. but there hasn't really been one solution that stands head and shoulders above the rest'. The hybrid powertrain has also been used to assist the internal combustion engine, improving power and reducing the emissions of trucks, SUVs and luxury cars. Lexus, Toyota's premium brand, has been working in this market. A hybrid executive car, like the Lexus GS 450h has CO<sub>2</sub> emissions of 186g/Km, which is considerably high. Nevertheless, the hybrid allows the equivalent consumption of a conventional 4 cylinder / 2.0 litres ICE (Toyota, 2008), with excellent performance, reaching 62 mph in less than six seconds. However, the Lexus GS 450h does not have the lowest CO<sub>2</sub> emission of its category, achieved by some slower diesel models.

Whether working to boost the power of the conventional engine and save fuel - like in the mild hybrids - or as a full hybrid, according to Menga (2008), hybrid vehicles appear to be the medium-term solution and the logical way to reduce the energy consumption of

today's conventional cars. As a milestone to the sustainable car, the aesthetic of hybrid cars should symbolise the evolution of automobile design. The leadership of the Toyota Prius is very representative in this way. The success of the hybrids also supports the development of battery technology, which might help to establish full battery electric vehicles with zero emissions.

### 2.1.10. Battery Electric Vehicle

In a scenario where the oil reserves will progressively disappear, increasing its price, and the CO<sub>2</sub> emissions and pollution standards will be more and more restrictive, the market for electric cars will grow constantly. The idea of an electric car is, though, as old as the invention of the automobile. In the beginning of the twentieth century, electric cars were important. 'Thomas Edison was one of the many who believed the future of the car lay in electric power, not gasoline or steam. Nearly a dozen companies, notably Baker (figure 16) and Brush, made electrics. Cleaner and easier to operate, electrics had special appeal for women. Most got about 40 miles per charge.' (Heimann and Patton, 2009).



**Figure 16: Baker Electric (1911).**

The electric car was progressively abandoned, while the internal combustion engine superseded battery technology, in terms of range and usability. The invention of the electric starter for the combustion engine in 1912, the increase in road range, and the low price of the Ford-T model are the reasons usually given for this. (Hasegawa, 2008)

In spite of no mainstream projects developing for electric cars, there were always small manufacturers developing electric models. Nevertheless, the standard of these cars helped to create a negative image of low quality vehicles.

In the 1990s, GM tried to bypass the Clean Air Act, California's regulations, and competitors' hybrid development stimulated by Clinton's Partnership for a New generation of Vehicles consortium with the release of an electric car called the EV1. The car was produced between 1997 and 1999, and could only be leased. The first generation GM EV1 used lead-acid batteries, which were big and heavy. For the second generation, GM installed nickel metal-hydrate, increasing the range by approximately 40%. The EV1s were claimed to be popular among the environmentally conscious, early adopters, and well-heeled celebrities. Following its success, Toyota, Honda and Ford also came out with their own EVs. (Hasegawa, 2008)

When North American government policy changed, the mainstream automobile industry ended its brief production of EVs. The EV1s were returned to GM and later destroyed (figure 17). In 2006, the infamous episode inspired a documentary film directed by Chris Paine: *Who killed the electric car?*



**Figure 17: Pile of Crushed EV1s.**

Hasegawa (2008) also notes that in Japan, Nissan produced a limited series of the small two-seater Hypermini from 1999-2001. The car used lithium-ion batteries developed by Hitachi, charged by induction.

The key factor to the development of the BEV is battery technology. Lighter and longer-range batteries will reposition the electric car in the consumer market. 'New battery types such as high-temperature batteries (e.g. AEG Zebra), nickel metal-hydrate batteries (e.g. Panasonic, SAFT), and lithium-based batteries (e.g. 3M, Matsushita, SAFT) will be available

in the coming years. Due to their extremely high-energy density, they will offer unprecedented vehicle ranges.’ (AVERE, 2008)

New technologies for fast charging are also improving the usability of the electric car. Adam Szczepanek (2008) explains that ‘today’s electric vehicles are typically equipped with an on-board charger, and the charging process takes up to eight hours. This significantly limits electric vehicles applications and market acceptance. In one ten-minute charge cycle, fast charge technology can provide enough energy to allow an electric vehicle to operate another hundred miles. This fast charge capability can help to enable rapid growth of the electric vehicle market by minimizing vehicle downtime.’

Named after the Serbian-American engineer Nikola Tesla, the North American manufacturer Tesla Motors is currently using the Lithium-ion battery to equip its Roadster model (figure 18). The all-electric sports car can accelerate from 0 to 60 mph in less than four seconds, reach a top speed of 135 mph, cruise about 250 miles at a stretch, and fully recharge in a couple of hours. (Jordan, 2006)



**Figure 18: Tesla Roadster (2007).**

The high cost of the technology is driving the development of cars like the Tesla and the Venturi. These models are flagship vehicles, carrying an additional symbolic value. It is a niche market, although they may help to create a different image of the electric car, usually associated with city cars, golf carts and a quirky aesthetic. Still, as an immediate solution ‘it is commonly agreed that purely electric vehicles are a sustainable alternative for commuters and low-mileage drivers. In this specific context they have a large potential for niche markets such as city delivery vans, buses or vehicles designed for a specific task (e.g. postal services)’ (AVERE, 2008).

Nowadays, most urban regulations only take account of the emissions created during vehicle use, benefiting electric cars. In London, UK, the small electric Reva G-Wiz is excluded from the Congestion Charge. This situation is helpful in lowering the local

environmental impact of the vehicle, especially in terms of noise, pollution and fuel distribution. However, this is not a complete analysis of sustainability issues. For example, the French government still supports the development of electric vehicles (Coroller, 2007), making use of nuclear plants to generate energy. This option is considered by many scientists and organizations neither safe nor sustainable (Menga,2008; Gott,2008, Greenpeace). On the other hand, it is possible to generate clean electricity from photovoltaics and wind turbines. With that in mind, Smart is planning to market the Fortwo in an electric version, selling only to customers who can guarantee the use of electricity from a renewable source. (Smart, 2007)

Moreover the electric car offers many possibilities for new car architecture: motors on wheels, Skateboard Architecture, Liquid Packing (Mausbach, 2008). Thus, it is expected that completely new design concepts may appear. Compared with biofuel and hybrid cars, the BEV will be offer a more significant change to the way we feel, see and drive cars.

#### **2.1.11. Hydrogen**

Another way to use the electric motor is by generating the energy in the car, though hydrogen fuel cells. Hydrogen is a secondary energy carrier, and as such must be produced. It is used as fuel for the internal combustion engine, in hydrogen vehicles (ICE-H<sub>2</sub>), and in fuel cell vehicles (FC). Menga (2008) observes that the effectiveness of hydrogen fuel cell vehicles depends substantially on the hydrogen production process: 'in the case of it being obtained by water electrolysis the overall advantage is comparable to that of natural gas (NG-ICE) vehicles or petrol mild hybrids, while a better picture comes in the case of direct conversion of NG into hydrogen.'

BMW has been developing hydrogen internal combustion engine vehicles since the 1980s. The production of the BMW Hydrogen 7 (figure 19) started in the end of 2006. 'The vehicles are not being sold, but instead are being loaned to public figures who will demonstrate a new, zero-emission energy era on this platform' (BMW,2008). The car is conceived as a hybrid petrol/hydrogen to solve the problem of the absence of hydrogen fuelling stations. The car has a total range of 700 km (200km on hydrogen and 500 km on petrol). The efficiency of the engine is considerably lowered when run on hydrogen. The original BMW 7 series V12 has 327 kW (445 hp) running on petrol and 191kW running on hydrogen. Nevertheless, the CO<sub>2</sub> emissions are lowered from 332g/km to 5g/km (BMW, 2008). The balanced emission of the Hydrogen 7 is 237g/km for the whole range (petrol + hydrogen). Regardless of the unimpressive numbers, this research is very

important to sustainability. Hasegawa (2008) add that 'the problem is cost. A single vehicle sells about US\$ 1 million, far out of mass-production reach.'



**Figure 19: BMW Hydrogen 7 in a hydrogen fuelling station.**

Another detriment of the hydrogen is the size of the fuel tank. Leonardo Fioravanti explained that when designing the hydrogen concept car, Thalia, 'the most important aspect we had to face was the fact that no fuel source yields the same amount of power as petrol. As a result, the fuel tank has to be larger than in a conventional car in order to ensure sufficient range' (Calliano, 2007).

Instead of using the combustion engine, it is also possible to use fuel cell and electric motors, improving the efficiency of the powertrain, and giving more freedom to the architecture. 'The fuel cell itself works by combining hydrogen (on the anode side) with oxygen (on the cathode side). The oxygen and the hydrogen are initially separated by a membrane. The hydrogen is separated into protons and electrons with the protons moving through the membrane (called the Proton Exchange Membrane or PEM), but the electrons travel around the electrically-insulated membrane and it is this movement of electrons that generates the power. The electrons then react with the oxygen to create water vapour, the only by-product of the whole chemical reaction. The reaction itself is extremely efficient: General Motors says that its fuel cells convert 36% of their energy into power, as against 22% for diesel engines and under 20% for petrol units.' (Clean Green Cars, 2008).

In 2008, Chevrolet started offering the Equinox Fuel cell, for test purposes only, in Los Angeles, New York and Washington. The Equinox is an SUV with a 93 kW hydrogen fuel



cell. Honda also planned to launch the fuel cell FCX Clarity, for lease only, by the end of 2008. The costs of purchase are also prohibitively high.

In 2002, GM developed the concept car Autonomy (figure 20), based on skateboard architecture, which concentrates the control system, powertrain, crush zones, and has electric motors inside the wheels. Powered by hydrogen fuel cells, the concept 'is an example of modular engineering designed to maximise flexibility. Rather than modifying the existing paradigm, these vehicles are examples of a return to first principles and are designed around user needs, economic production and use.' (Andrews et al. 2002)

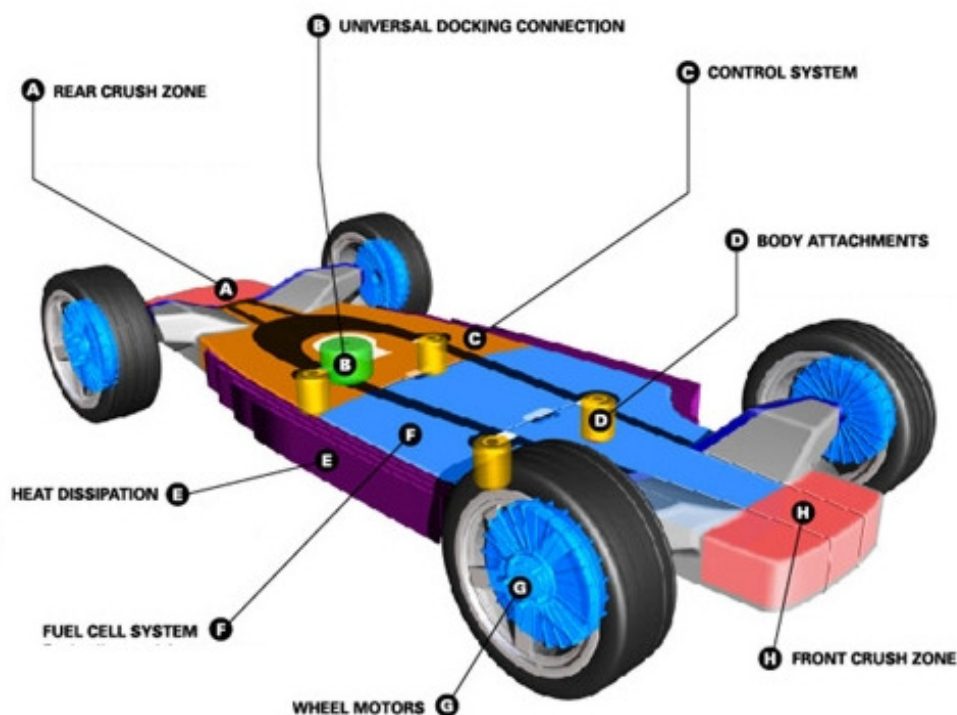


Figure 20: GM Autonomy Skateboard Architecture (2002)

Research by Clean Green Cars (2008) found the evolution of fuel cell technology has been slow in the last 10 years. Some scientists claim that fuel cell cars will be competitive by 2035 (Kloess et al. 2008, Ajanovic et al. 2007). What is certain is that the evolution of the fuel cell has been extremely slow in the battle against environmental degradation.

## 2.1.12. Solar and Wind Power

Others resources can be used to create electricity for vehicles, such as wind turbines and solar panels. These are clean and sustainable options. However, due to the large surface area of photovoltaic required, or the significant size of turbine necessary to generate the

energy needed, it is easier to add this to the electricity mix, than to have the energy generated in the car.

Actually, wind turbines have to work as stationary devices, but Venturi Automobiles has designed one to be connected to their Eclectic electric car while parked (figure 21). Venturi claims that it adds 15 km per day to its range. The car also features solar panels in the top of its roof, adding more than 5 km to its range (Venturi, 2007). However, the car needs to be a plug-in battery electric car to have reasonable autonomy.



**Figure 21: Venturi Eclectic (2006).**

To be able to run solely on the energy supplied by the solar panels, a vehicle has to be much more aerodynamic and light, like the solar cars built for special races. Photovoltaic technology does not provide enough power to run a car matching current user demands, in terms of either comfort or built-in equipment.

Solar panels are being incorporated into contemporary cars, like the third generation Toyota Prius, to give additional power to run the climate-conditioning system while the car is parked or the combustion engine is turned off.

The clean generation of energy is, however, essential in a sustainable electric car. Wind, tidal and solar power have a significant value in a sustainable transport infrastructure. Their participation in the energy mix is already increasing.



Concerning photovoltaic power, Prasad and Snow (2004) point out that 'in the developed world, of the 1328 MW installed in 2002, almost 80 percent was installed in Japan and Germany alone. In 2002, Japan achieved the highest installed power per capita (5W/capita), above Germany (3.37W/capita) and Switzerland (2.67W/capita).' The total power installed increased tenfold from 1992 to 2002. According to Prasad and Snow (2005), photovoltaic is a technology whereby sunshine is converted into electricity, which generally uses the following solar panel options:

- Mono-crystalline silicon cells (m-Si). High efficiency, between 12-15%, with a maximum recorded outdoors of 22.7%.
- Poly-crystalline (p-Si). Medium efficiency, between 11-14%, with a maximum recorded outdoors of 15.3%.
- Dye-sensitised solar cells (DCS)/ Artificial photosynthesis ( $\text{TiO}_2$ ). Very efficient at 10%. Provided through a wide range of sunlight conditions.
- Amorphous silicon cell (a-Si). Less efficient, between 6-8%. Nevertheless these are cheaper and require less material. a-Si are used in watches and calculators, can be curved and fold-away modules.

Regarding wind power, Hickman (2005) states the technology is arguably the most promising renewable energy source in the UK. The 1034 wind turbines installed over the last 14 years provides 700MW. The plan is to increase this number to 7000MW in seven years.

### **2.1.13. Aerodynamics**

Andrews, Shacklock and Ewing (2005) observe that 'it is likely that in response to legislative and market demand for more efficient vehicles and lower-polluting vehicles, in addition to the development of more efficient engines and new fuel systems, emphasis on vehicle aerodynamics and subsequent reduction of drag coefficients will assume even greater importance within the automotive design process. Although automotive manufacturers refer to the non-dimensional coefficient of drag ( $C_d$ ) in publicity and other material, it is the product of drag coefficient and the frontal area ( $C_d.A$ ) that must be considered when calculating drag. (...) The frontal area ( $A$ ) of vehicles influences overall aerodynamic drag so the smaller vehicles with lower  $C_dA$  and similar engines tend to be more fuel-efficient. However, the design and dimensions of the frontal area are constrained by ergonomic considerations, fashion and consumer demand for stylistic similarities at a given time'. In the other hand, the aerodynamics defines shape and has an

immediate effect on aesthetics. Andrews, Shacklock and Ewing (2005) suggest that 'aerodynamic optimised vehicles would be virtually indistinguishable from one another, and because consumers demand a level of design individuality, would not be deemed acceptable'.

**History** | The form of the car evolved essentially from horse-drawn carriages. Vittorio Marchis (2008) points out that while the automobile was created by implementing an engine in a carriage, the aeroplane, however, constrained by its purpose and nature, had to be designed following aerodynamic principles from the very beginning. These principles also made the aeroplane form more original and a reference point for innovation and modernity. From the aeronautics industry came not only inspiration, but professionals who designed vehicles by aiming to transfer aerodynamics expertise to cars. The German aeronautic engineer Edmund Rumpler created, in 1923, a proposal for an aerodynamic car: the Tropfenwagen. Nevertheless, the Cd was as high as 0,54 because the aerodynamic design was conceived bidimensionally, only taking account of the sides of the car. (Vieira, 2009)

The Alfa Romeo Castagna, the Rumpler Tropfenwagen and Paul Jaray's designs are other early examples of aerodynamic experiments, with a radical approach to shape. Later, in the 1930s, streamlining was largely adopted throughout car and product design. Phil Patton (2007) suggests that 'streamlining helped produce a tradition of automobiles that were works of art, high style, great art, and cultural power.' Designed and built 'on the conviction that the most efficient form must also be the most beautiful'.

Engaged in the same quest, Alberto Morelli, Sergio Pininfarina and Renzo Carli built the Grugliasco Wind Tunnel. From the aerodynamic studies made there, Morelli developed a groundbreaking aerodynamic shape, resembling a dolphin, that achieved a Cd as low as 0.055 when close to the ground (Marchis, 2008). The shape, known as Il Delfino (figure 22), inspired the research done later, in 1978, by Pininfarina and the Italian National Research Council (figure 23). At that time, the focus was on developing new shapes to improve aerodynamics and reduce fuel consumption.

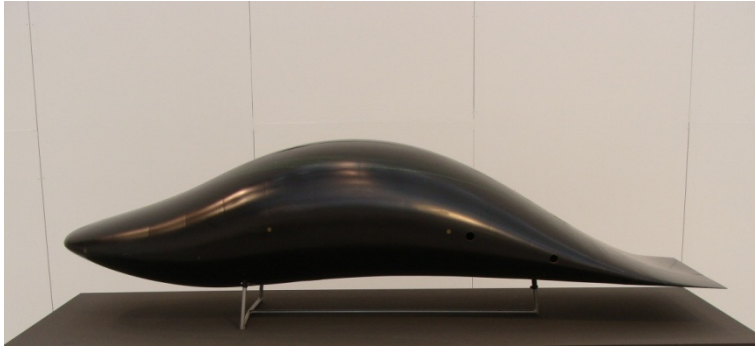


Figure 22: Il Delfino (1956).

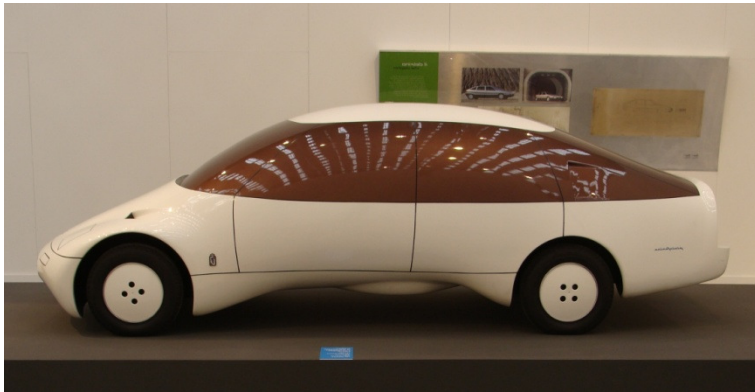


Figure 23: Pininfarina CNR Research Model (1978).



Figure 24: GM EV1 (1997).

The same basic profile would inspire production models later, in 1997, when the GM released the EV1 (figure 24). 'With a listed drag coefficient of 0.19 ( $C_dA=0.38m^2$ ), however, this vehicle evidently benefits from and is closer to an aerodynamic ideal than many other vehicles.' In comparison, the second generation Toyota Prius has a  $C_d=0.29$ ,  $C_dA=0.7m^2$  and fuel consumption at 4,9L/100Km (57.6mpg). The first generation Honda Insight has a  $C_d=0.25$ ,  $C_dA=0.57m^2$  and runs at 3.4L/100Km (83mpg). (Andrews et al. 2005)



**Figure 25: Audi A2 (1999).**



**Figure 26: Toyota Prius (2004).**



**Figure 27: Honda Insight (2010).**

The Prius (figure 26) and the second generation Honda Insight (figure 27) make use of the aerodynamic principles of Kamm/Koenig-Fachsenfeld. According to Robert Cumberland (2009b), Reinhard Koenig-Fachsenfeld, a former motorcycle racer, and Wunibald Kamm - whose name is commonly applied to the truncated tail featured both on the Insight and

the Prius - headed the Research Institute for Motor Vehicles and Engines in Stuttgart from 1930 until the end of World War II and lent his prestige to the development of Koenig-Fachsenfeld's aerodynamic patents. Together they built and tested a series of experimental, Prius-like "K-cars".

The 1952 Borgward Hansa was one of the first cars to use this aerodynamic principle, but Cumberland (2009) considers the best application was in the 1999 Audi A2 (figure 25). With an aluminium body, it was light, less than 1900 pounds in its super-economical '3 Litre' form, despite meeting all safety requirements. The '3 Litre' in its name indicated its fuel consumption - three litres per 100 kilometres, or better than 78 mpg, thanks to an aluminium, 1.2 Litre, three-cylinder turbo-diesel, making 60 hp. With skinny tyres and a low-drag shape, Audi claims that its 0.25 Cd makes the lowest coefficient-of-drag sedan ever mass-produced.'

According to Andrews, Shacklock and Ewing (2005), 'aerodynamics drag is comprised of four principal elements: pressure drag (backward force), viscous friction (boundary layer), induced drag (induced upwards or downwards) and interference drag (imperfections or ventilation inlets).' Thus, 'air resistance affects a moving vehicle in three ways: 'by flowing around the vehicle, by flowing through the body, and within the processes of the machinery itself. Hence for an average ICE passenger car, at approximately 67Km/h, aerodynamic drag and rolling resistance are equal. At 100Km/h, however, aerodynamic drag accounts for 80% of road resistance and rolling resistance only 20%.'

#### **2.1.14. Rolling Resistance**

Considering that the average cruise speed inside cities is lower than 67Km/h, the rolling resistance is also a very decisive factor in the ecological performance of an automobile. Tyre technology is the main issue for rolling resistance. At the 2009 Geneva Motor Show in Switzerland, some of the world's leading tyre manufacturers showed their commitment to environmentally directed product development.

Dunlop developed the exclusive concept tyres for Pininfarina's electric car concept. 'Pininfarina BlueCar: a revolutionary ultra-lightweight tyre using DuPont Kevlar fibre instead of steel. (...)Kevlar is a synthetic fibre five times stronger than steel on an equal weight basis and maintains its strength and resilience in a wide range of temperatures.(...) The Dunlop tyre (figure 28) on the Pininfarina is extremely lightweight, which would lead

to less rolling resistance and thus less fuel consumption. Dunlop claimed the concept tyre, designed together with Pininfarina, is 20% lighter than standard ones. (Dunlop, 2009)



**Figure 28: Dunlop Pininfarina Ultra-Light Weight Tyre (2009).**

Goodyear launched the EfficientGrip. According to the company, it 'delivers important fuel savings while offering high mileage and excellent wet braking performance levels, thanks to the tyre's innovative FuelSaving Technology. The term 'FuelSaving Technology' comprises several technological advances that directly affect the tyre's rolling resistance, which is the key performance indicator when aiming for lower fuel consumption and CO<sub>2</sub> emissions. (...) EfficientGrip offers additional environmental improvements beyond its fuel consumption benefits and the reduced CO<sub>2</sub> emissions. The silica tread compound uses the latest generation of polymers and, in line with the European legislation, does not contain any highly polycyclic aromatic oils. The EfficientGrip is 10 per cent lighter than its predecessor and due to the fact that less material is used in the tyre itself, carbon dioxide emissions have been reduced during production. Less material for the tyre production, combined with the fact that fewer tyres are needed to achieve a given mileage, ultimately leads to less material to be recycled at the end of the tyre's life. (Goodyear, 2009).

These achievements are very important, but the recycling process cannot be left out of the design, however, if it aims for a more sustainable solution. The disposal of used tyres is a worldwide problem, as is the waste trade industry, that shows inequalities which are unacceptable in the context of sustainable development, every country must be responsible for the end of life of its own tyres.

### 2.1.15. Design Concept

In relation to design, the synthesized process of ideas regarding the development of a product or service, the aspects covered in the previous sections might appear combined or isolated on many different design solutions of future and current automobiles.

Furthermore, some design processes alone might lead to a more sustainable solution.

Papanek (1984) stated that 'designers help to wield power to change, modify, eliminate, or evolve totally new patterns'. He advocates that it is the designer's responsibility to design for people's needs rather than for their artificially-created desires, to understand the limits of mass-production and the meaning of obsolescence.

In his 'Manifesto for eco-pluralistic designs, to create more sustainable products / materials / service products for a more sustainable world future', Alastair Fuad-Luke (2002) lists the following aspirations:

- Design to satisfy real needs rather than transient, fashionable or market-driven needs.
- Design to minimize the ecological footprint, reduce resource consumption.
- Design to harness solar income.
- Design for disassembly
- Design to exclude the use of toxic or hazardous substances..
- Design to use locally available materials and resources.
- Design to dematerialize.
- Design to maximize benefits to society.
- Design to encourage modularity, facilitate repair, reuse and improvements.
- Design to foster debate and challenge the status quo surrounding existing products / materials / service products.

Some of these concepts are unlikely to be seen in the automotive industry, unless, as Papanek believes, designers assume a proactive position. Like the levels of intervention noted by Manzini and Vezzoli (1998), the design concept can increase ecological benefits the more involvement it has in the development of products and services; from design for disassembly, to total design, to system design.

**Design For User Needs** | As observed by Papanek (1984), 'recent design has satisfied only evanescent wants and desires, while genuine needs of man have often been neglected'.

According to Alison Black's User-centred Design Glossary (Design Council, 2009), to design around user needs requires the 'analysis of the needs of people who will use products and services, ideally based on observation.'

This process acts as foundation to a *form follows function* method and involves developing designs focusing on the early levels of its hierarchy. Functionality needs - related to the most basic design requirements; reliability needs - establishing stable and consistent performance; and usability needs - how easy and forgiving a design is to use; set the main course of the design process. (Lidwell et al. 2003)

Designs made this way easily achieve savings in material dimensions and weight. The Smart Fortwo can be understood as a modern application of this concept.

**Design For Disassembly** | If pre-use and post-use phases are included in the design process, it is possible to achieve better ecological performance, even when using the same material dimensions. Design For Disassembly is a method that concerns the post-use phase of an object.

According to Manzini and Vezzoli (1998), Design For Disassembly means conception and design for disassembly where materials and parts can be easily separated. This helps in repairing, maintenance, recycling, re-use of materials and subsequent re-production. It is good for material-life extension and product-life extension and to isolate toxics and harmful materials. It is an essential process to facilitate recycling. The FIAT Cascade, previously cited here, is an example of this process.

**Total or Whole Design** | The terms *total design* or *whole design* describe a more holistic approach to design. Stuart Pugh is usually associated with the term 'total design', which he defines as: 'the systematic activity necessary, for the identification of the market/user need, to selling of successful product – an activity that encompasses product, process, people and organisation.' (Andrews et al. 2007)

According to Pahl and Beitz (1984) the method encompasses the following phases:

- Clarification of the task: collect information about requirements to be embodied in the solution and also about the constraints.
- Conceptual design: establish function structures, search for suitable principles, combine into concept variants.



- Embodiment design: starting from the concept, the designer determines the layout and forms and develops a technical product or system in accordance with technical and economic considerations.
- Detail design: arrangement, form, dimensions and surface properties of all the individual parts finally laid down; materials specified technical and economic feasibility rechecked; all drawings and other production documents produced.

The linearity of the process, as most models suggest, is rarely the case. (Andrews et al. 2007)

Nevertheless, a total design process may increase the innovation input in a design. Thus, concepts aimed to break with traditional automotive paradigms, like the GM Autonomy (quoted at sections 2.1.11 and 2.2.5), are likely to be the consequence of a whole design process.

**Designing Systems** | To satisfy user needs, it is also possible to design a system that provides the results that the user expects from the product. Mobility companies are thus becoming more common, signalling a possible future for the automotive industry.

The company Better Place has designed an operation system for an electric vehicle, aiming to transform the transportation grid, but delivering the result the user expects from an automobile in a more sustainable way. The AutoOS system, created by Better Place includes: charging at the user's homes; software to analyse the user's journey and project the range of the battery; in-board navigation system that shows the user parking spaces in the city where it will be possible to charge the car; outdoor charging devices; battery exchange stations (figure 29), where the user can simply get a fully charged battery in a few minutes; an information system, connecting the navigation software, charging stations and the user's mobile phone. The company expects to deliver an annual saving of US\$2000 to the average North American consumer, and all the benefits from CO<sub>2</sub> emissions reduction. (Roth, 2008) Better Place founder, Shai Agassi, established agreements with Renault - 'that commits both companies to a volume of at least 100,000 electric cars in Israel and Denmark by 2016', and other partner companies, including Continental of Germany, Flextronics, Intel, Microsoft, and TÜV Rheinland; to help Better Place scale up global production of its EV services platform and deployment capabilities.' (Better Place, 2009) The Renault cars adopted by Better Place were simply converted to electricity. The cars don't represent a total design process and don't communicate the ecological benefits they may achieve.



**Figure 29: Better Place Electric Car Battery Swap Station (2009).**

According to Manzini (2006), 'the designers' possibility of promoting successful sustainable solutions is based on their ability to present to their possible users some alternatives that they can recognise as better solutions (to their need and desires) and that, at the same time, may be considered as more sustainable solutions (from a social and environmental point of view). When this happens, designers, and the companies that practically realises and delivers the solutions, enable the users/clients to shift from an un-sustainable system and un-sustainable behaviours, to more sustainable ones. Some implicit assumptions of this statement have to be made explicit: What users demand is not a given system of products or services, but the results that these products and services enable them to achieve. The same demand for results may change in time, when new results substitute the old ones.' The assumptions also demands that user's comprehension of the benefits of a more sustainable design is decisively necessary. Thus, the automobile aesthetic will have to express the shift to a more sustainable mode.

## 2.2. The Automobile and Aesthetics

### 2.2.1. Introduction

Design practice deals with man's ability to change the environment, the transformation from natural to artificial. This principle accounts directly for environmental impact, but has, or might have, however, the intention of providing means and tools for improving human quality of life. It was assumed that the Industrial Revolution and the enhanced scale of production would extend the benefits, hypothetically, to humanity. What is observed today is the opposite: the real advantages of mass-production have not reached humanity equitably, and facing their negative consequences, like the growing gap between more and less developed countries, rich and poor, and environmental degradation, was not prioritized during the process. It is from this context that we judge and experience industrial production and design.

**Aesthetic Experience** | The process of understanding or judging design objects is mostly an aesthetic experience, as explained by theories of Stuart Walker – whose work is the main reference point of this research. Walker (2001) suggests that our aesthetic experience of an object is a consequence of our contextual experiences, divided into natural, spiritual and ethical. The first accounts for interaction with the physical world – natural or transformed environments. The second represents the search for meaning or the psychological association that values the object beyond its material issues. The third one deals with the social consequences of our behaviour and meaning of our personal relationships.

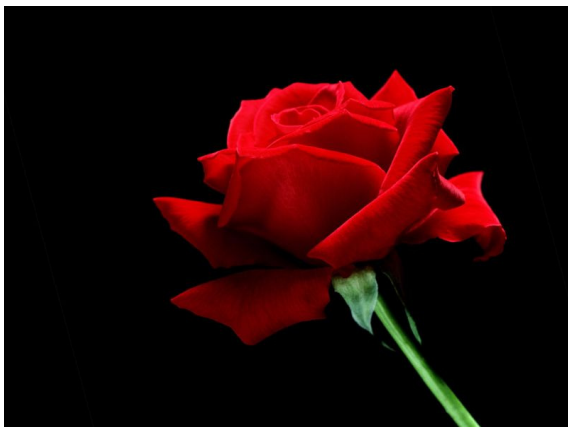


Figure 30. A red rose.

A red rose (figure 30) can be used to exemplify Walker's aesthetic theory. The interaction with its physical perceptions, colours, textures and smell creates information we associate with beauty and pleasure. The metaphysical meaning given to the flower, relating it to passion and love, accounts for the spiritual context. The possibility of having a rose through fair-trade means might suit the ethical context of sustainability.

Walker (1997) also points out that 'the aesthetic experience involves beauty, taste, sensory response and contemplation. And 'taste' is culture-, time- and place-dependent. Therefore as societies and cultures change and as their knowledge and understanding evolve, so tastes change.' Thus the aesthetic value of an object differs from person to person, but it follows collective patterns of behaviour and depends on access to information. Goldman (2001) adds that 'the focus on experience becomes natural, even inevitable, once it is recognized that beauty and other aesthetic qualities are not simply intrinsic properties of objects themselves, but essentially involve responses on the part of perceiving, cognizing and feeling objects.'

The Thames and Hudson *Dictionary of Art Terms* defines 'aesthetic' as 'a coherent system of criteria, which can be purely visual, moral or social, or any combination of these, used for evaluating works of art' (Lucie-Smith, 1984). Goldman (2001) notes that 'the term 'aesthetic' was first used in the eighteenth century by the philosopher Alexander Baumgarten to refer to cognition by means of the senses, sensuous knowledge. He later came to use it in reference to the perception of beauty by the senses, especially in art. Kant picked this use, applying the term to judgements of beauty in both art and nature. The concept has broadened once again more recently. It now qualifies not only judgments or evaluations, but proprieties, attitudes, experience and pleasure or value, and its application is no longer restricted to beauty alone'. Thus, context contributes to an aesthetic judgment of an object, as much as the analysis of the object itself.

Goldman (2001) states that 'the aesthetic proprieties to which one pays attention are not simply objective proprieties of works, but relational properties partly constituted by one's response when fully engaged by the aesthetic object. To be fully engaged is not simply to pay close perceptual attention to formal detail and complex internal relations in the object's structure, but also to bring to bear one's cognitive grasp of those external and historical relations that inform one's aesthetic experience, and to be receptive to their qualities that emerge through this interactions.'

To explain the influence of the context in the judgment of an object, Datschefski (2001) refers to Albert Einstein's statement: 'The world we have is the product of our way of thinking'. Walker (2006) indicates that to a great extent, the aesthetic qualities of a product are a function of the system that produces it. 'It follows that the aesthetics of most consumer products are, in fact, the aesthetics of immoderate waste and environmentally and socially damaging practices'.

The understanding of the negative impact of the automobile in the environment tends to change the judgment of the people about its necessity and importance. A polluting object, which contributes to the decreasing quality of the urban environment, configures a negative aesthetic experience. Therefore, it causes the progressive change of automobiles from being beautiful to being ugly.

Nevertheless, acknowledgement of the climate crisis creates a great opportunity for renewal in the car industry and design, prioritizing a more sustainable model. Also, according to Walker (1997), 'product aesthetics would start to embody and reflect a system of production which is sensitive to the environment, respectful of human dignity and social equity, and indicative of an approach which values diversity, harmony and equilibrium. (...) The aesthetics of sustainability are not so much an objective, but more a result of systems of design and manufacturing which are consistent with sustainable principles. (...) If the system of manufacturing itself adheres to sustainable precepts, then product aesthetics will embody and reflect the sustainable values inherent to that system.'

Walker (2006) also states that 'the creative and visualization abilities of designers give them a unique and potentially influential role in the process of reframing objects so that in their materials, manufacture and appearance, they are in accord with, and expressive of, sustainable principles and meaningful human values. We can infer from this that sustainable objects will be markedly different from existing products and will be identified through a rather different aesthetic typology.'

**Beauty and Design** | Datschefski (2001) explains that 'it's no longer enough that a product is pretty on the outside, cheap and available'. In the context of sustainability the beauty has to be total. The Longman *Dictionary of Contemporary English* (1995) relates beauty to appearance, good quality, advantage, good example and approval. Beauty accounts for the positive aesthetic experiences, pleasure and joy. Beauty creates attractiveness and desire. According to McMahon (2001) 'that beauty evokes an experience of pleasure is

probably the only point on which all participants in the continuing debate on beauty agree.'

Plato's writings on art are the earliest contribution to the study of aesthetics (Janaway, 2001) and makes him 'of all philosophers...the most poetical' (Sidney, 1973). To Plato, beauty was an object of love, and not explicitly linked to pleasure. 'Pleasure was too transient and subjective a response to characterize our response to beauty (even pure and true pleasures, presumably). Plato clearly did not limit his idea of love to sexual desire' (McMahon, 2001).

Moreover, Freud's 'pleasure principle', which has dominated our culture's popular understanding of human nature, and Darwin's legacy, sum up the view that 'beauty would seem to be all about sex appeal'. The Freudian-Darwinian biology-sex notion of beauty 'describes beauty as a standard of physical appearance to which we are attracted through genetic predisposition because such beauty in a person indicates a person's capacity to produce healthy offspring.(...) By contrast, Marxism and its theory of alienating power of cultural institutions, has been responsible for aligning beauty with the values invented by the ruling classes to subjugate and control the masses' (McMahon, 2001). Thus, in the Marxist vein, beauty could be used as a means of controlling society through aesthetic paradigms that could also support power structures and mass-production principles of standardization.

Brought to the world of mass-production, beauty is an essential attribute of car culture. Robert Cumberland points out that people 'choose cars because of the way they look and because of how we think they make us look' (2006). A beautiful car is desired and attracts people. People understand cars as an expression of themselves, and want cars to make them appear beautiful.

According to Brian Sewell (1999), '*beautiful* is a difficult word: when we attach it to the world *car* we seek to lift the automobile out of the category of tool or object and convert it into art'. Peter Stevens (1999) considers that 'the idea of elevating the car to become an art form presupposes art is somehow higher than design. Stevens argues that 'it is certainly more 'difficult' for both artist and observer, but that does not make design lower, or any less worthy. So why not celebrate automobile design for its style, creativity and craftsmanship, if that is what it deserves. Probably because style and its practice, styling, is seen as a superficial pastime, creativity is considered self-indulgent, craftsmanship is difficult to spot in the modern car.'

Sudjic (2008) observes that 'it is a curious paradox that even the most materialist of us tend to value what might be called the useless above the useful. Useless not in the sense of being without purpose, but without utility, or at least not much of it. (...) A Ferrari attracts more attention than a Volkswagen, but it is hardly a practical means of urban transport. And at a more fundamental level, while art is useless, design is useful. So Picasso is a far more central figure to the culture of the twentieth-century than Le Corbusier, and *Guernica*, if it were ever to be sold, would command a far higher price than the Unité d'Habitation.' Sudjic (2008) adds that 'perhaps the divide between art and design is not as sharp as is sometimes suggested. Whether it was acknowledged or not, design has always been about more than immediate utility.'

Design is, according to Sudjic (2008), 'about the creation of anonymous mass-produced objects, by people who spend a lot of time worrying about injection moulding, or about the precise degree of curve needed to blunt the sharp edges of a monitor screen. It is also about making objects that feel good to touch and used. (...) Design in all its manifestations is the DNA of an industrial society - or post-industrial society, if that's what we have now. It's the code that we need to explore if we are to stand a chance of understanding the nature of modern world. It's a reflection of our economic systems. And it shows the imprint of the technology we have to work with. It's a kind of language, and it's a reflection of emotional and cultural values.'

Stevens (1999) suggests we should not 'obscure the elegant solution to an engineering problem with inappropriate labels'. The elegant solution, which creates a pleasant aesthetic experience, is then the forever chased beauty, expressed through the language of design.

Cumberford (2006) points out that 'philosophers from ancient Greece to the present have concerned themselves with defining beauty. One universal idea is to equate beauty to pleasure, whether that pleasure be ineffable or carnal, the pleasure derived from a landscape or viewing a beautiful human. Desire, pleasure, and beauty are interlinked in all that we do, think, or imagine, so it is not surprising that we seek - and find - beauty in automobiles.'

References to beauty in Western Europe have their roots in the Classical period, mainly from Greek and Roman cultures. The period is considered 'of highest achievement and purest form of a style or technique' (Mayer, 1969). Achievements represented through architecture - epitomized by the Parthenon and its ubiquitous colonnades and portico;

and sculpture - the Venus of Milo as the symbol of beauty, and the Victory of Samothrace (figure 31) as the symbol of strength and speed. The Classical Period created canons of beauty based on perfection. 'The harmonious proportions and over-perfect anatomy of the figures indicate that they were idealized portrayals of the human body rather than individual portraits' (Mayer, 1969).



**Figure 31. The Victory of Samothrace (Approximately 200 B.C.).**

The purism and perfection of form of the Classical period was revisited in the Renaissance, through Classicism and Neo-Classicism. Later in the twentieth century, the Victory of Samothrace and the Parthenon were reinterpreted in Rolls- Royce's radiators. Thus, either through making use of icons or by designing through its principles of harmony and purism, the Classical Period influenced the machine age.

Martera and Pietrogrande (2008) note that in Italy, a country recognised for its importance for Classical art and the Renaissance, the beauty of the human body was replaced by that of the machine, *La Bellezza della Velocità*, profoundly connected to the concept of modernity. Thus, the car became an inspirational object to fine-arts, as shown in figure 32.



Sewell remembers that 'when the car first came to the roads a century or so ago it was no more than a mechanical means of personal transportation, a replacement for the horse, but once the simple principles of transferring power from an engine to the road wheels were established, it became a creature of the imagination, soon recognised by the Italian futurists as an image, an icon and allegory of speed and freedom, or power and dominance, as effective as the human body had been in personifying such abstractions since the days of ancient Greece.' Thus, while the world was being transformed by mass-production, the Futurist Manifesto proclaimed the arrival of a new beauty, the one of Speed (Perfetti, 2008). The fourth clause of Filippo Marinetti's Futurist Manifesto of February 1909, proclaimed:

*'We affirm that the world's magnificence has been enriched by a new beauty: the beauty of speed. A racing car whose hood is adorned with great pipes, like serpents of explosive breath - a roaring car that seems to ride on grapeshot is more beautiful than the Victory of Samothrace.'* (Marinetti, 1909)



Figure 32: Gualtiero Pizzetti, Trittrico della velocità - III) L'arrivo (1926).

## 2.2.2. A story of fantastic artistry and inventiveness

According to Margolius (2000) at the beginning of the twentieth century 'the machine became the essential vehicle of modern form when mass-production replaced craft and manual skill. New artistic trends elevated the inherent formal beauty of the machine by abstracting aesthetic elements from the machine world, applying them to art. The automobile was regarded as the typical machine to source design ideas, a metaphor for modernity and progress. (...) For Le Corbusier, machines were manifestations not burdened or compromised by tradition and historical inheritance.' Even so, similarities in usability means that the design origins of automobiles have been influenced by horse-drawn carriages, while airplanes were more functional and independent.

If we take the Benz Patent Motorwagen, as a starting-point, automobile history has passed the 120-year mark, and through some clearly recognizable stages. From 1886 onwards, is the period named here as the first age of car design: The Age of Pioneers. Automobile design of this period is strongly related to the design of horse carriages. An understanding of the design process of this age is essential to understanding current developments in ecological vehicles. In the early years of the industry, advances in technologies were the primary target, but the status of art was only reached when the car obtained aesthetic significance, an identity as a object. Bayley (2008) observes that 'at first, the car resembled what was quite literally a horseless carriage, but as the technology became more familiar, as cars became more democratically accessible, no longer aristocratic playthings, artistry begun to intervene.'

From the beginning, while becoming the materialization of modern man's desires and aspirations (Montemaggi, 2008), at the same time the car has developed its own mythical context. 'Freedom, style, sex, power, motion, colour - everything is right there', according to Tom Wolfe (1966). Jane Jacobs wrote in *The Death and Life of Great American Cities* (1961) that 'the purpose of life is to produce and consume automobiles'. 'To Ford the car was an absolute democratic necessity, a utilitarian tool, an impression of man's ingenuity and his freedom. To Alfred Sloan, from General Motors, the same car represented an opportunity to seduce the consumer with ideas of social competition and cultural modelling'. It was Alfred Sloan who hired Harley Earl and created the Art and Color Department at General Motors. While in parallel, design consultancy was being established as a modern professional business in New York, with Raymond Loewy, Henry Dreyfuss and others opening their studios. 'Consumers were moving beyond mere subsistence into complex areas of taste' (Bayley, 1999). There was much more to expect

from mass-production products, they had to attract the consumer, to communicate different qualities, and to express personality, value and innovation. This investigation brought to car design an identity, standing a long way from horseless carriages. Thus the modern automobile was born in the 1930s, and reached mass-production after the Second World War, a consequence of its evolution in technology and aesthetics (Tumminelli, 2008).

The modern automobile had its previously separate parts - fenders, lights, boot, engine and passenger compartments - integrated into one shell or whole-body. The Evolutionary Age, from the whole-body designs of the mid20th.century until today, can be considered the second era of car design. Different countries assumed different positions throughout this evolution: the Italian *carrozzeri* were responsible for refining style; the French companies for creating aesthetic surprises; the Germans for mastering technology; the North Americans for constantly upsizing products, and the Japanese probably the opposite.

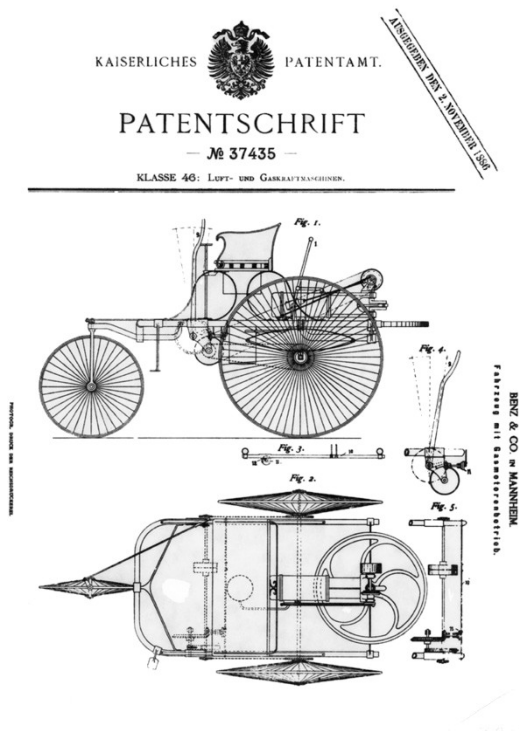
During the Evolutionary Age, car design evolved with many different trends, but most of the time referring to its own past. According to Walker (2006) 'here then is the paradox of aesthetic definition. It is informed by convention – our conventional notions of beauty and taste. But it is this very influence of convention that results in the endless regurgitation of variations on a theme and imprisons product design in its own cage of introversion.' This is part of the reason some authors consider that we have reached the end of an age in car design, or even the end of the automobile itself.

The Evolutionary Age had also suffered with the circumstances of crises. Significantly, the post-war context directed the evolution of European popular cars, while North American prosperity was more effectively affected by the oil crisis of 1973. When increasing oil prices hit the world again at the beginning of the 21st. century, it was clear that merely recovering economic strength would not save the world from a worse menace, climate change.

As a result, car design is about to enter a new period, when most of the paradigms in aesthetics and technology will shift: The Age of Sustainability. The next sections will observe the aesthetics of the two previous ages, through the study of styles and trends in relevant automobiles, which are also positioned in the Car Design Timeline presented here as a frontispiece. In addition, a number of concept cars, designed along sustainable principles, will be analysed to investigate future trends in the Age of Sustainability.

### 2.2.3. The Age of Pioneers

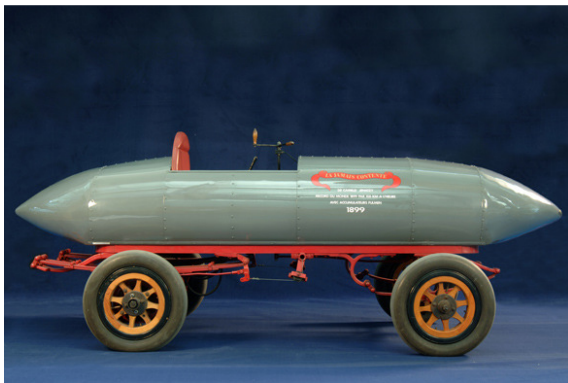
**Inventions** | Nowadays, the 1886 Benz Patent Motorwagen (figure 33), which successfully achieved auto-mobility capacity with a combustion engine, looks like a naked car, showing its architecture and all the mechanical parts; yet the beauty of the details and craftsmanship, not to mention the immensurable spiritual and aesthetic value this historical object represents.



**Figure 33: Benz Patent Motorwagen (1886).**

The reliability and performance of the engine was Benz's most important triumph. The cars of the first age came at a time when inventiveness in machine technology was the avant-garde. The new products had to wait for decades to evolve to a more suitable shape, an identity. Maldonado (2006) points out that in the last two decades of the 19<sup>th</sup> century, due to safety reasons, machines began to be covered to protect people from workplace accidents. Thus, the structural and the mechanical elements were hidden, creating a dichotomy that has influenced not only machine design. The relation between form and function was exhaustively investigated through the 20<sup>th</sup> century, and straightforwardness of machine design and perfectionism of nature used to justify the pure excellence of functional aesthetics.

The last decades of the 19<sup>th</sup>. century was a period of inventions: John Boyd Dunlop invented the pneumatic tyre, the Cogent Safety Bicycle appeared in 1877, Robert Bosch patented his low-voltage magneto ignitions for stationary petrol engines in 1887 and ten years later for vehicle ICE, and Nicolaus Otto created a reliable four-stroke engine, to name a few (Vieira, 2008). It was also the era of pioneers in aviation, with Santos-Dumont's and the Wright brothers' successful enterprises. And, of course there were Thomas Edison, Marconi, Tesla, Bell, and many other conquerors in the fields of communication and electrically-powered equipment.



**Figure 34: La Jamais Contente (1899).**

Electric automobiles, as mentioned before, were also popular and reached important achievements. La Jamais Contente (figure 34) was the first car to go over 100 kilometres per hour, and it was electric. Its body was shaped like a torpedo, resembling an aeroplane without wings. The design clearly focused on a more aerodynamic solution to reach the speed record, and created an unusual body style, but at the same time, an ambiguous metaphor.

**Carriages** | 'Electric and steam cars were in the majority in the USA in the early part of the 20<sup>th</sup>. century. Companies like Baker, Woods and Detroit Electric developed electric vehicles that were clean, reliable and easy to start. (Macey and Wardle, 2008). Nevertheless, petrol cars were slowly dominating the market worldwide.

Bayley (2008) points out that 'by about 1901, the fundamental architecture of the car had been established by Daimler's 'Mercedes' (figure 35) (although here's a clue to the way development was going: Mercedes was named after a girl, the daughter of a Daimler importer). There were four wheels. There were usually four passengers, one of them behind the wheel (although at the very beginning it was a tiller). One of Otto's internal

combustion engines was mounted to the front or rear, the bodywork might be open, like a buggy, or closed like a state coach'. Bayley (2008) adds that 'car vocabulary includes words such as 'berlinetta; and 'limousine', derived from old coach types, themselves inspired by urban destinations.'



**Figure 35: Mercedes 35HP (1901).**

'Early automobiles were custom-made, ordered almost like suits or dresses from a tailor. Typically, the chassis and engine were sold as a unit, while bodies were purchased from an entirely different manufacturer - often carriage-makers or coach-builders who might still be supplying the horse-and-buggy market' .(Heimann and Patton, 2009). Therefore, their aesthetics were naturally linked to carriages. The square angles and vertical lines were typical of their ancestral vehicle, and not representative of dynamism. The wheels were very similar to the ones used in carriages, and placed laterally to the body with their mudguards. The passengers were very exposed, without any regard for safety.

Some of the initial paradigms were about to be changed, when Henry Ford started producing the Model T. The automobile began to be not just an exclusive toy for the aristocracy. The Ford Model T democratized the luxury of travel. According to Bayley (2008), 'the Model T's development was the US system in miniature: as sales rose, prices dropped'. Simultaneously, while the automobile became a feasible dream to many, it was also a new objective for life, a goal modern man would fight for when working every day in the new industrial society. Symbolically, the production line of the Model T was much bigger than the plant at Highland Park, but included millions of Americans working to create income to pay for the dream. The Model T denoted the capitalist model of growth, as Henry Ford realised that the more people you have making money, the more buyers there will be for automobiles. The system benefits from having more consumers, and at the same time people have to belong to it to buy its products. The Myth of Freedom was



being born, and the masses wanted to travel, to conquer - the modern version of sovereignty.

*'Two generations of Americans know more about the Ford coil than the clitoris, about the planetary system of gears than the solar system.'* (John Steinbeck, 1945, from Bayley 2008)



**Figure 36: Ford Model T production line.**

The Ford production line (figure 36), inspired by a visit to a Chicago slaughterhouse, changed the world and motorized North America. However, the Model T, which brought auto-mobility to the masses, and represented this innovative period of machine design, inspiring many artistic trends, was still closely connected to carriages in its design language. The innovations were neither technological nor aesthetic, but social and commercial. Henry Ford's major concern was the scale and speed of production, which led to his famous pronouncement –'any colour, as long as it's black' – black being the fastest drying paint available. (Bayley, 2008)

According to Tom McCarthy (2007), mass-production meant massive environmental impact in other areas of the life cycle of the product, from larger demand for oil and raw materials to the production of waste, which Ford was especially concerned about reducing. 'Mass automobile ownership brought the American automobile market to the

'saturation point' crisis of the mid-1920s, as consumers clamoured for greater variety in cars so that they could distinguish themselves from one another and producers sought better ways to sell replacement vehicles sooner'. (McCarthy, 2007)

**Limousines** | Sergio Pininfarina (2008) points out that during the 1920s, 'years of enthusiasm and wealth, the automobile becomes more rich and sophisticated, and therefore the big luxury car bodies from Packard, Hispano Suiza, Rolls-Royce, Bentley, Bugatti, make their appearance'.

Rolls-Royces were also famous for their reliability and good performance, reaching high speeds at Brooklands race track, and travelling long distances without breakdowns. The Silver Ghost, which earned its name after its silent ride, was also quoted as 'the best car in the world' by *Autocar* magazine by that time. The Silver Ghost limousine (figure 37) became even more famous later, as a die-cast toy produced by Corgi. The performance of the real car, nevertheless, was what created new standards of comfort that many others would try to emulate. (Vieira, 2009)

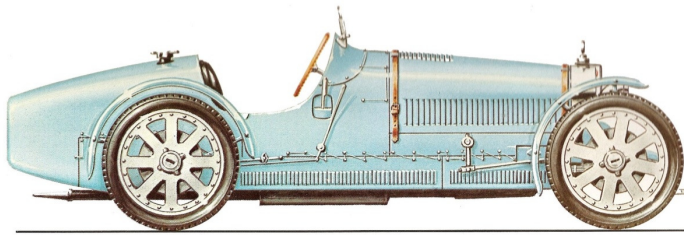


**Figure 37: Rolls-Royce Silver Ghost (1912).**

Maybach, Duesenberg, Stutz and Bugatti were other companies producing these long wheel-base cars, with large interior space, sometimes with separate compartments for the chauffeur. The elegance of the long car body emerged from this concept of luxury and power, taken to the limit with the Bugatti Royale. The car had a enormous 250bhp engine and a long and strong chassis able to support the biggest, heaviest and most expensive car bodies (Vieira, 2009). The limousines' comfort paradigm was about more luxury, more power, more status, the bigger the better, something that almost could be measured in the length of the bonnet. Nevertheless, it was a difficult paradigm to sustain during the 1929 crises.



**Cigars** | On the other hand, Bugatti also became famous for light and agile sports cars. Selected by Robert Cumberford (2008a) as 'the best racing car design of all time', the Bugatti Type 35 (figure 38) 'handled better than anything else on the road, allowing high average speeds despite a power deficit compared with many contemporaries. (...) The 35 had wonderful cast-aluminium wheels, influential to this day (...). The bodywork, with its chisel-shaped tail, was copied from the 1922 Fiat 804 grand prix cars but had the first application of the horseshoe radiator outline, characterizing all the subsequent Bugattis. (...) The hood slopes down from the cowl toward the radiator, giving the car a nicer profile than keeping its top parallel to the ground. Art, not Science'.



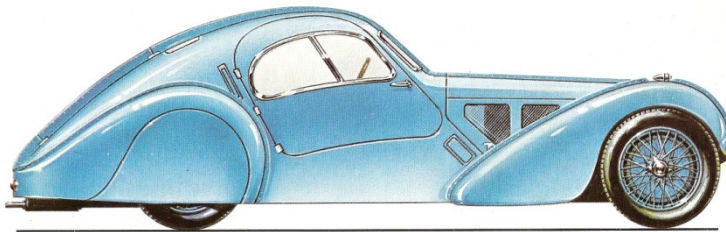
**Figure 38: Bugatti Type 35 (1924).**

It was a racing car, yet there was not much distinction between racing cars and road cars by that time. The same car was sold to amateurs and professionals. The car was 'genuinely beautiful' according to Cumberford (2008a), 'so tractable that, fitted with lamps and fenders, it could be a daily driver, its legendary capabilities were more than backed by reality'. The basic typology of the 35 was common to sports cars and racing cars, the difference often resting on the number of seats in the vehicle. Single seat cigars remained the archetype of the racing cars. The cigar bodies developed into the more organically designed, aerodynamic shapes that made Alfa Romeo's reputation before the war and afterwards, with Enzo Ferrari running their Grand Prix team.

Nevertheless, Ferdinand Porsche challenged convention in 1936 with the Auto Union C. The revolutionary racing car Porsche designed had a mid V16 engine producing 520bhp. The car, intended to demonstrate German superiority, not only won 32 of 54 grand prix races entered (Vieira, 2009), but also gave a new direction to the development of high performance cars, also affecting their aesthetics, considerably changing their architecture and proportions.

**Streamlining** | Speed evolved as a myth, with the fantasy of the grand prix, became an inspiration to the Futurist artists and was used as a marketing tool by the automotive industry. Patton (2007) points out that, nevertheless, production car speeds remained mostly below 50 mph. It was only 'almost forty years after the invention of the automobile that manufacturers made serious efforts to reduce drag'. Thus, streamlined cars started to appear. 'Streamlining symbolised progress, faith in the constant benefits of technology, and a delight in the increasing speed and excitement of life'. (Patton, 2007)

With streamlining, car design started distancing itself from the design language of carriages, and becoming closer to high technology-based style, even if it was purely empirical. Vehicle design language began to gain more originality, and some models emerged as true objects of beauty, like the Bugatti Type 57 Atlantic, considered by the stylist and car collector, Ralph Lauren to be 'probably the most beautiful car in the world, both in details and its overall shape.' (Kimes and Goodfellow, 2005).



**Figure 39: Bugatti Type 57 Atlantic (1937).**

Designed by Jean Bugatti, the Type 57 Atlantic coupé was based on the Aerolithe show car, which was built of magnesium and aluminium. Since these materials couldn't be welded or soldered, Bugatti riveted the body of the Aerolithe externally, creating the signature seam down the middle of the car. The French press claimed the Aerolithe 'encapsulated *l'art moderne* and was a paean to the new school of scientific streamlining. Jean Bugatti was encouraged to press on in his exercise in futurism.' (Kimes and Goodfellow, 2005). The Atlantic went into production, and epitomized the controversial, delightful and flamboyant aesthetic of the brand, which was soon to die with Jean and Ettore.

Streamlined cars demonstrated how design was evolving in the frontier between art, commercialism and science. Harley Earl is considered to have developed most of the practices used until now in car design, between them, the concept cars - nevertheless, there had been show cars before. In 1937 he released the Buick Y-Job concept car (figure

40), which influenced design aesthetics beyond the limits of car design. The streamlined lines and slender proportions of the Buick were a universal design trend in the following decades, while car design progressively acquired a high status as an aesthetic reference.



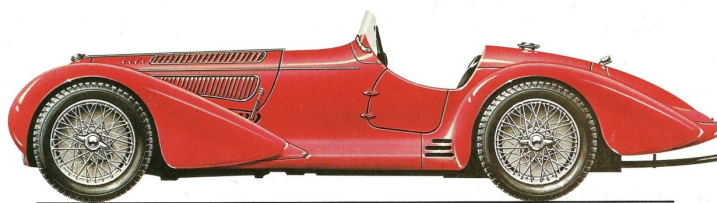
**Figure 40: Buick Y-Job Concept Car (1937).**

In North America, between the production cars, the streamlined Chrysler Airflow was a sales disappointment, in spite of the great promise shown when it was introduced at the New York auto show in 1934. The problems of the Airflow came more from engineering than style, and streamlining became popular.

Patton (2007) remembers that, in the 1930s, streamlining was adopted as an antidote to the Depression. 'In the United States, streamlining came less from the wind tunnel than from style and promotion, so objects that didn't move were streamlined at the same time or sooner than ones that actually did - like automobiles. (...) In ancient Greece, Zephyr was the god of the west wind. In 1930s America, Zephyr was the name of a passenger train, an electric clock, and a clever office gadget, later called the Rolodex. Most famously, Zephyr was the name of the 1936 Lincoln that the Museum of Modern Art called 'the first successful streamlined passenger car in America'. According to Cumberland (2007b), the car also coined the expression 'catwalk cooling', when Bob Gregorie turned the grill sideways so that it took in air on each side of the sharp prow. This is a term less important today than it was sixty years ago, when fenders were distinctly separate from the engine compartment or rear bodywork' (Cumberland,08.2009). This was an important step in the direction of whole-body shells, with a definitive influence on the aesthetic of the next generations of cars.

**Pre-Classic** | The streamlined shape, handled with care by the finest coachbuilders of the 1930s, enabled some of the most influential design before the rise of the modern car. These designs can be considered Pre-Classic cars.

'When it comes to pre-war automobiles, Alfa's 8C 2900 (figure 41) shows the creative process at its finest' (Kimes and Goodfellow, 2005). The 8C is considered by many to be the first supercar, and also one of the most beautiful cars of all time (Jennings, 2006). According to Cumberford (2009d), the *Superleggera* (superlight) construction technique, and the powerful 'roaring' engine, made it the most extraordinary performance car of its time. The 8C was successful at the Mille Miglia race, to the delight of Alfa's team manager, Enzo Ferrari (Jennings, 2007a).



**Figure 41: Alfa Romeo 8C 2900 (1935).**

The Alfa Romeo 8C 2900 was designed by Amedeo de Micheli and Giovanni Rossi, at Carrozzeria Touring, Milan. Its lines flow from front to rear, with teardrop-shaped fenders, a common feature on sophisticated cars of that time. These Pre-Classic curved surfaces were also used for the Talbot-Lago and the Delahaye by Figoni & Falaschi, when customization and exclusivity were required by rich clients wanting to show their cars at automobile beauty contests, such as that at Lake Como's Villa d'Este. 'Italian consumers were catching on to the benefits of style that would establish the difference between themselves and others who were fortunate enough to possess a private means of transport' (Kimes and Goodfellow, 2005).

Edsall (2008), remembers that the majority of the refined designs, however, were created in France. Pre-war Paris attracted not only Figoni, Falaschi and Bugatti, but also avant-garde artists, musicians and writers, including Pablo Picasso, Salvador Dali, Igor Stravinsky and Ernest Hemingway. In the USA, also with closely related to avant-garde art, a number of daring new designs appeared, like Gordon Buehrig's Cord 810/812, with its unconventional art-deco grill and hidden headlights.

**Pre-Modern** | The assumption that car design just emerged from marketing, technical and ergonomic concerns would be incorrect, or incomplete. The relationship of car design to art movements was often close. The car designing profession itself also developed also from a human resource mixture of professionals from diverse backgrounds, such as engineers, architects or artists.

Before joining Citroen, Flaminio Bertoni was a sculptor and painter, with connections to both Futurism and Surrealism. It is said that he designed the Traction Avant (figure 42) in one night, with sculptor's tools. The car used a rare unitary construction and the body was much lower than its contemporaries, made possible by the front-wheel drive architecture, pioneering a mass-produced family car with a defining influence on its aesthetics. The Traction Avant was André Citroen's equivalent to Henry Ford's Model T, but it was more luxurious and safe. Another important innovation of this car was the fact that it was put through a crash test. (Bayley, 2008)



**Figure 42. Citroen 11CV Traction Avant (1934).**

The 1934 Citroen Traction Avant has been called a 'pre-modern popular car' by Paolo Tumminelli (2004) He explains that 'basically, automobiles in the pre-war period were a combination of different functional and clearly identifiable parts: engine space, headlights, fenders and passenger seating. Space for a boot was even uncommon; and generally, loading a single suitcase was enough.' However, in spite of having parts of the architecture easily recognizable in the form, Pre-Modern cars were definitively distant from horse-drawn carriages, especially when compared to previous generations of mass-market cars.

Some Pre-Modern cars, particularly popular ones, also survived after the Second World War. The Citroen Traction Avant continued in production under the Michelin ownership of Citroen until 1957, selling approximately 800,000 units. (Bayley, 2008) The most famous

of these enduring designs is probably the Volkswagen (figure 43), the bestselling car of all time with 21,529,464 units sold up to 2003. (Chapman, 2007)

The Volkswagen was initially developed for the German National Socialist government by Dr Ferdinand Porsche. The brief was to build a car for the people that could be bought by customers with a budget of 1000 Reichsmarks. The Volkswagen was initially called the Porsche Type 60, and later known as *Käfer* in Germany, Beetle in English, and their equivalents in many other languages. The body was designed by Erwin Kommenda following the aerodynamic principles of Paul Jaray, and it was the basis for the later development of Porsche's own sports cars. Nevertheless, in 1955, the State Patent Office in Mannheim recognized that the design was based on a proposal presented in 1925 by Bela Beranyi, who was compensated with the symbolic value of One Deutsche Mark (Bayley, 2008).



**Figure 43: Volkswagen Prototype (1935).**

Few Volkswagens were produced before the war. Production started again in 1945, producing an additional income for Porsche's own design company. The first models had a 1100cc engine, which reached 1600cc in the later versions. The car created a new paradigm of freedom. Being affordable and well engineered, the Volkswagen was practical, economical and cheap to maintain (Holloway and Buckley, 2002). Although it changed people's lifestyle, its basic architecture did not become ubiquitous as the image of the car.

The reliability and low price of the Beetle made it possible for the car to survive after the war, when variety and novelty started to inform design. The creation of the Art and Color Section at GM, headed by Harley Earl, symbolized the beginning of the cultural revolution of consumerism, but also the cultural revolution of the language of objects in industrial design, from that point on, with ever-increasing importance. However, the Beetle was a



movie character to Disney, an icon, and icons had their place when anonymous design came to populate the traffic jams.

**Utility** | During the Second World War, while the industry was living a sad silence, many car designers were focused on developing vehicles for the war. Ferdinand Porsche worked on the development of German tanks and was arrested by the French after the end of the war, together with his son Ferdinand Anton Porsche, also known as Ferry. They were later released after paying a fee. Louis Renault, on the other hand, died in prison before even being able to prepare an appeal against the accusation of having had collaborated with the enemy. Renault lost control of the company to government agencies (Vieira, 2009). The Bugatti factory in Molsheim was confiscated by the Germans during the war. Following the liberation of France, Bugatti went to court to reclaim his factory. However, by the time the case was won, Ettore Bugatti was in a coma, and he died without knowing the outcome (Kimes and Goodfellow, 2005).

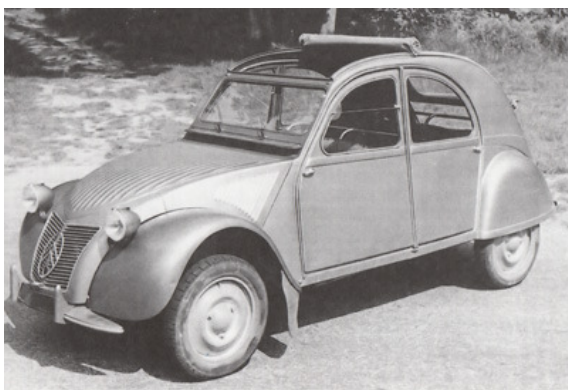


**Figure 44: Jeep (1941).**

Also during the war, in the USA., a new icon was designed. A war hero, a soldier, a General Purpose vehicle, from the acronym sound, named Jeep (figure 44). 'The US military wanted a replacement for the ageing motorcycles with side cars used in World War I, and the Model T Ford had proved itself too fragile for the job' (Holloway and Buckley, 2002). Ford, American Bantam and Willys-Overland responded to the US government's 'Request for Bid'. 'The winning submission came from automotive engineering consultant Karl Probst, who worked for the American Bantam car company. The design was created with the help of Harold Crist, Bantam's factory manager, over four frantic days in July 1940' (Lorio, 2007). In the end, Willys was selected to mass-produce the car, but Ford also produced it.

The Jeep was considered by President Eisenhower to be one of the two most significant pieces of equipment of the war (Bayley, 2008). The Jeep was a practical and reliable tool in the context of war. The four-cylinder engine could run at 4000rpm for 100 hours without a break, and was easy to repair. The Jeep could cross muddy roads and climb 40-degree slopes. The design was based on functionality, and the design language expressed the robustness of a soldier. The surfaces were plain and strong, and represented more the need of mass-production than the symbolism of a suit of medieval armour. One might still relate it to the Model T, but the way its front fenders were shaped and connected to the main body is totally straightforward and the aesthetic is as strong as the object itself. Nevertheless, the Jeep might be considered as an evolution of the roughest capabilities of the Model T. The rear wheels were incorporated into the main body and together with its strong squared shape demonstrate the solidity of the vehicle. Throughout the whole vehicle, it is difficult to find one single design detail that was not based on function, making the Jeep probably the best example of a 'form follows function' aesthetic.

The Jeep made itself a icon of the war, in the same way that sports cars did in racing. After the end of the war, from servicemen to the Department of Agriculture, there was a demand for the new icon. Thus, the Civilian Jeep was launched and produced throughout the next decades, becoming a brand itself, and evolving its branch of models. The vehicle created such a strong product identity from a functional aesthetic that it is likely to be seen as a modern design. Together with other Pre-Modern cars, like the Volkswagen and the Citroen 2CV (figure 45), the Jeep was a survivor of the Age of Pioneers into the next period.



**Figure 45: Citroen 2CV (1948).**



The Citroen 2CV was meant to be utilitarian and popular, and shared with the Jeep some of its design philosophies. 'Bauhaus principles of truth to materials and geometrical purity were fundamental to its conception, although the brief was in fact more homespun: the TPV (Toute Petite Voiture) was to carry a *paysan* (peasant) with 50kg of agricultural goods at 50Km/h. Besides the expressive Bauhaus logic, there was a rationale for its appearance. The semi-unitary body was inexpensive to make, as it used mostly flat stampings, which were also easy to repair.'(Bayley, 2008)

Flaminio Bertoni designed the unique body, but the history of the project dates back to Pierre Boulager's 1936 concept, and expressed the architectural philosophy of Jean Prouvé. The original concept 'was the result of 10,000 opinions sought in a market research exercise unusual for its day' (Bayley, 2008). After the war, Boulager and André Lefebvre developed the car that would match perfectly the particular peculiarities of the French market, and populate the roads of the country. Thus, as Sudjic (2008) observes, without consciously trying to make a car that looked French, the 2CV became the car whose style reflected their particularities.

#### **2.2.4. The Evolutionary Age**

Although some eternal icons, like the Volkswagen and the Jeep, were designed before 1945, the effects of the Second World War were enough to reorganise society, promoting a renewal of industrial activity for different objectives, as diverse as the American Rocket cars and the Germans' Kleinwagen. It was a time to bring new ideas for renewing both design and society. In the automotive industry, some existing trends were revisited but with a subtle and decisive evolution of their design language. For this reason, many consider the modern car to have emerged in the post-war period. It was then that the automobile acquired its identity, with a design language distinctly independent from that of the horse carriage, and became even more iconic and celebrated. It was the beginning of the Evolutionary Age.

Battista 'Pinin' Farina had started his own company before the war, after an intensive research visit to the Ford factory in the United States of America. After the end of the war, he started work again with no difficulties (Vieira, 2008) and soon released new important cars, the company being known as Pininfarina. According to Felicioli (1998b), Pinin 'was adamant that aeroplanes would play a major role in the evolution of transport and the transformation of society.(...) Pinin could not bear ornamentation, gratuitous decoration and repetitiousness of formal precepts reduced to the function of reassuring

commonplaces.' Pinin Farina always shared with Lancia a taste for innovation. In 1937, they launched the Lancia Aprilia 'berlinetta aerodinamica'. As Felicioli (1998b) points out, 'Aerodynamics was not only a metaphor of speed. It was also a way of breaking the rules that crystallised the system of etiquette and stuffy formality typical of all archaic societies'.

Together, the 1939 BMW Mille Miglia and the Lancia Aprilia influenced Pininfarina's most illustrious design: the 1947 Cisitalia 202 (figure 45). Moreover, Cisitalia founder Piero Dusio asked his engineer Giovanni Savonuzzi to design a car as wide as his Buick, low like a grand prix car, as comfortable as a Rolls-Royce and as light as the Cisitalia single-seater. (Jennings, 2006). The design was later brought to development at Carrozzeria Pininfarina. The Cisitalia was a seminal moment in post-war styling, according to Holloway and Buckley (2002). 'It featured a bonnet positioned lower than the wings, headlights that blended into the wings - rather than being free-standing - and smooth, sweeping, simple lines. Pininfarina explored these themes in other chassis, but it is the Cisitalia that is best remembered', in part, also because of being the first automobile to be acquired for the permanent collection of an art museum.

The Cisitalia 202 was one of the cars selected in 1951 by curator Arthur Drexler for an exhibition called 'Eight Automobiles' at the New York Museum of Modern Art, directed by the architect Philip Johnson, head of the museum's Architecture and Design department. The significance of the relationship between car design and art was, more than ever, exposed.

The work of the Italian coachbuilders, like Pininfarina, Touring, Ghia, Zagato and Bertone, also known as *i carrozzieri*, established the tradition of Italian design with enormous attention to style, and an emphasis on proximity to art practices. The *carrozzeri* were typically independent companies producing bodies on established chassis types, and later also started developing concept cars. The independence of the *carrozzeri* was essential to the free exercise of creativity, resulting in the inventiveness and refinement of Italian design. They played an important role throughout the Evolutionary Age, and the Cisitalia 202 epitomizes the arrival of the modern car.

*'An automobile is a familiar twentieth-century artefact, and is no less worthy of being judge for its visual appeal than a building or a chair. Automobiles are hollow, rolling sculptures, and the refinements of their design are fascinating.'* (Philip Johnson, 1951)<sup>5</sup>



**Figure 46: Cisitalia 202 (1947).**

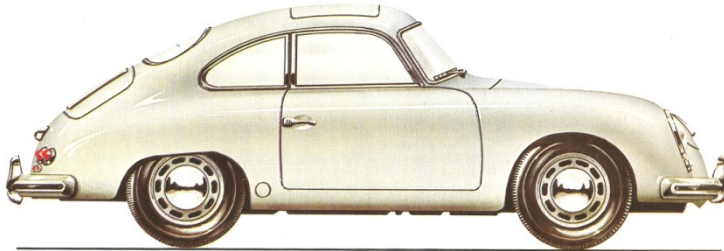
**Shells** | Pininfarina designed the Cisitalia with the parts of the car that were usually separate incorporated in a single shell. The design moved from showing the basic architecture of the machine to the identity of a whole-body: according to Paolo Tumminelli (2008), the modern car was thus born.

The independent industrial designer Raymond Loewy, working for Studebaker, also helped to define the whole-body shell. He designed Soft Shells for the Champion and Flow Shells for the Starliner. There is not much distinction between the two styles noted by Tumminelli (2008), both presenting unbroken lines from front to back - by this time called the Proton Side Design. However, Soft Shells had more static lines, and appeared on many popular post-war cars, and some luxury sedans. Flow Shells, on the other hand, were more streamlined. The cars often had the hood placed lower than the fender. The style

---

<sup>5</sup> The Exhibition Eight Automobiles was held at the New York Museum of Modern Art. The selected cars were: 1930 Mercedes-Benz SS, 1947 Cisitalia 202, 1939 Bentley 4 1/2 Litre, 1939 Talbot-Lago, 1951 Willys Jeep, 1937 Cord 812, 1948 MG TC and 1941 Lincoln Continental. (Chapman, 2007) According to Margolius (2000) the famous 'rolling sculptures' quotation was first coined by the architect Philip Johnson.

was common to gran turismo and sports cars, like the Porsche 356 (figure 47), the company 's first car as an automobile manufacturer. According to Tumminelli (2008), the Shell theme dominated car design until the end of the 50s; one could also say, however, that Porsche has never abandoned it.



**Figure 47: Porsche 356 (1948).**

The long life of the Citroen DS (figure 48) also contributed to the enduring permanence of the trend. 'When the unique DS came out, nobody could believe that it was part of a series. Inside and out, as well as in every detail, this model is one of the most innovative vehicles in automobile history, from its whale-like shape to the half-transparent glass fibre roof (Tumminelli, 2004).

According to Holloway and Buckley (2002), when the DS was launched, it was a decade or two ahead of its time. By the end of the day it was launched, at the 1955 Paris Motor Show, Citroen had taken 12,000 orders for the car (Glancey, 2003). Roland Barthes, after witnessing the launch of Flaminio Bertoni's new design for Citroen, compared it to a Gothic cathedral. 'Both, he argued, represented the same aesthetic value and were results of comparable intellectual effort; both were artistic masterpieces' (Margolius, 2000).

The Citroen DS, also called The Goddess, embraced more innovations in a car than ever before. Among them were the hydraulic suspension, power steering and hydraulic assisted brakes, redefining standards of comfort for family cars, and offering a 'magic-carpet ride' (Holloway and Buckley 2002). With all its innovation and avant-garde style, the DS was able to remain on the market for twenty years, and became a new French automobile icon.

*'I think cars today are almost the exact equivalent of the great Gothic cathedrals; I mean the supreme creation of an era, conceived with passion by unknown artists, and consumed in an image if not in usage by a whole population which appropriates them as a purely magical object.'* (Roland Barthes, 1957)



**Figure 48: Citroen DS (1957).**

**Minicars** | Jonathan Glancey (2003) observes that in 1945, much of Europe was in a 'sorry state'. In Great Britain, most car owners were allowed just five gallons of petrol per month, so small and economic cars would offer a great deal. Lawrie Bond, a miniature car specialist, started offering a car at 'austerity programme' running costs.

Throughout Europe, manufacturers - particularly those with expertise in aircraft and motorcycle manufacture, designed their cars to compete in this market. 'Isa's Isetta was the first of the famous Italian bubble cars, later made and developed under licence by BMW '(Glancey, 2003).

The Isetta (figure 49) was designed to use engines of a standard motorcycle size. The rear wheels were so close that one might think it was a three-wheeler. The architecture of the bubble cars was uncompromising. The Isetta had only one access door, at the front. The Messerschmitt - designed by an ex-aircraft company - had two tandem seats and an aeroplane-like cockpit.



**Figure 49: BMW Isetta (1955).**

The shells, when reduced to these dimensions, resembled an egg or bubble, which gave them these kind of nicknames. Nevertheless, the aesthetic, with their aeroplane and motorcycle influences, was rather futuristic, matching the age of the 'Space Race', which was about to start.

Closer to an automobile aesthetic, but not less extravagant, was the FIAT 600 and Nuova 500 (figure 50). The FIAT's Minicar was mass-produced in millions to fit the budget and diverse needs of the Italians. The car was produced in many different special editions, from the Abarth sports versions to open top models, beach cars with no roof and basket-weave seating, and the Multipla, a multifunctional station wagon for up to six persons. (Tumminelli, 2004).



**Figure 50: FIAT Nuova 500 (1957).**

The Cinquecento remained an Italian icon, to be revisited successfully in the future. The British equivalent, the Mini (figure 51), redefined Minicars forever. The compact packing developed by Alec Issigonis, with a transverse engine, front-wheel drive and small wheels that didn't intrude on passenger space, was the great achievement of the car. Another

major innovation was a new rubber-cone suspension system designed by Dr Alex Moulton. (Holloway and Buckley, 2002)

If it had only been notable for its body style, a scaled-down version of the XC9001, maybe the car would not have achieved all the success it had. Although, even with a sad-looking face on its front end, the styling had subtle, well-finished lines, matching the rationality of the concept with a touch of 'unconscious chic' by Issigonis (Bayley, 2008). According to Sudjic (2008), 'it is not just how an object looks that is the key to the creation of an archetype': the Mini was a combination of technical innovation and formal invention. Thus, the car surpassed its competitors in comfort and performance, and proved it in motor sport too.

Nevertheless, for capturing the imagination of the general public the Mini's appearance in the Peter Collinson film *The Italian Job* was more effective than the car's showing of its real capabilities when it won the legendary Monte Carlo Rally three times.

*'Because it was so radical, the Mini was impossible for a snobbish British consumer to categorize and thus, astonishingly, became the first small car to be perceived as classless. No one said it at the time, but in the Mini great design proved to be universally alluring'. (Stephen Bayley, 2008).*



Figure 51: The Mini in the film *The Italian Job* (1969).



**Rocket** | Prominent in people's fantasies was another post-war style theme, the Rocket. Typically North American, and really only thriving in their big cars, it was inspired by aeroplane lines, but at the same time, totally opposite to aircraft design principles. Rocket cars grew unnecessarily big, heavy, and adorned, as an aeroplane would never have done. It was purely formal styling, and it came from the mind of the designer considered by many as the father of styling: Harley Earl.

During the war, Harley Earl and his staff made a visit to Selfridge Air Force Base to get inspiration from the Lockheed P-38 aeroplane, which was, according to Bayley (2008) 'one of the most formally inventive and radical aircraft shapes'. Although they were not allowed to come closer than nine metres to these war heroes, it was inspiring enough: 'the projectile nose, the cockpit greenhouse, the beautifully contoured fuselage and (especially) the twin tail booms'.

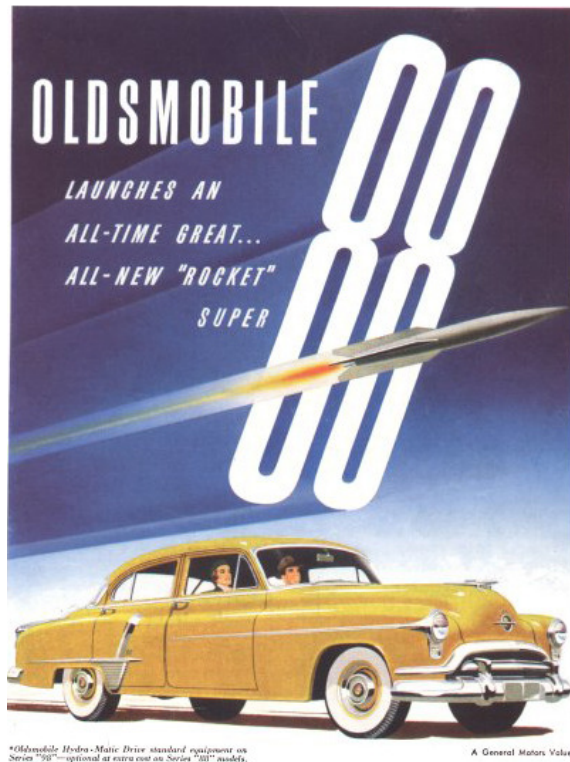


**Figure 52: Lockheed P-38 Lightning (1941).**

Design elements from planes then started to be unconsciously incorporated into cars: a projectile-like front, panoramic, dome-shaped roof, wings, fins, and jet-pipes - as Tumminelli (2004) observes, originally intended for real jet engines. Thus, Harley Earl applied tail fins to the 1948 Cadillac and later on to the 1949 Oldsmobile. The latter also became famous through Jackie Brenston's song *Rocket 88*, recorded in 1951 by Ike Turner at Sam Phillips' studio, and considered by some to be the first rock and roll song. While Arthur Drexler was selecting cars for MoMA, the recording represented another aspect of the sociology of the automobile. It was inspiring not only for its harmony of shapes, sometimes only understood by art critics, but also through the popular fantasy of 'freedom, style, sex, power, motion, colour, everything', to quote Tom Wolfe (1966).



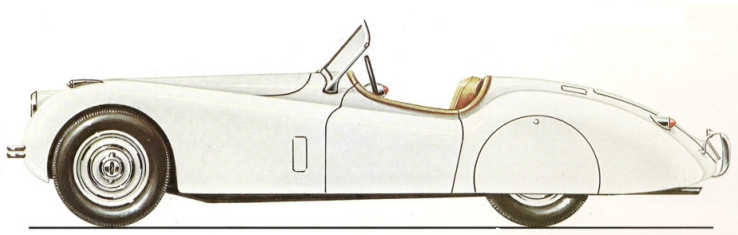
*You women have heard of jalopies,  
You heard the noise they make,  
Let me introduce you to my new Rocket '88.  
Yes it's great, just won't wait,  
Everybody likes my Rocket '88.  
Babe we will ride in style,  
Movin' all along.  
V-8 motor and this modern design,  
Black convertible top and the gals don't mind.  
Sportin' with me, ridin' all around town for joy.  
Blow your horn, Rocket, blow your horn!...  
(Jackie Brenston)*



**Figure 53: Oldsmobile Rocket 88 advertising (1951).**

Tumminelli (2004) notes that although it is difficult to take this automobile dream seriously, 'the child-like optimism and revolutionary vision even seem impressive today'. Nevertheless, the excessive use of chrome, decorations and huge fins led to an exaggerated baroque style. The cars grew longer than ever, making a statement about North American wealth. This design euphoria lasted until the end of the decade, but the distance between American and European aesthetics, however, was enhanced and would endure much longer. Rocket cars, rock and roll, suburban life, were all influential images of the 1950's American Dream, unlikely to be understood and remembered separately, offering an aesthetic harmonised with its context.

**Classic Line** | The Classic Line design represents the automobile establishment of the post-war period. Technically engineered to a high performance, aesthetically the cars were a 'mixture of new with tried and tested qualities' (Tumminelli, 2004). The Classic Line had a more conservative approach, if compared with Soft and Flow Shells. The general proportions are reminiscent of pre-war Pre-Classics and their precedents, the Limousines: the cars were long, slender and high. Classic Line design can also be understood as a British counterpoint to American Rockets, reflecting a society rebuilding itself on its values and traditions. Interesting, nonetheless, was the fact that some of these cars were designed and produced in England to sell in America.

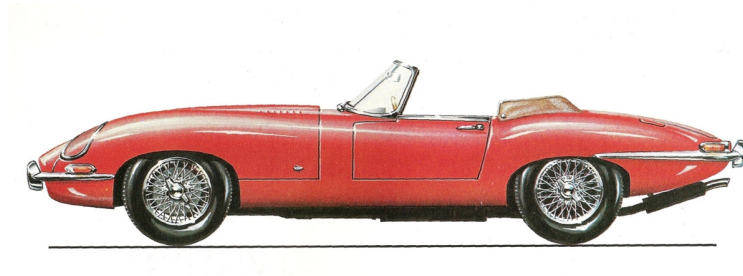


**Figure 54: Jaguar XK120 (1949).**

The Jaguar XK 120 was one of these Classics. The car was designed by Sir William Lyons using a panel beater, putting his ideas directly into sheet metal, influenced significantly by the 1939 BMW 328 Mille Miglia (Jennings, 2006). Comparing its front light clusters, the roundness of its front wings and the slope from the grill to the bonnet with the contemporary Cisitalia 202, the Jaguar is clearly more conservative. Nevertheless, the car was extremely well accepted when launched at the 1948 London Motor Show, initially as a showcase for the Jaguar's new 6-cylinder twin overhead cam engine. The XK was produced until 1961 with a successful formula based on high performance and traditional styling. According to the English racing driver Sir Stirling Moss, 'the XK120 made such an impact that everybody wanted one. But they were nearly all for export so you couldn't buy one for love nor money' (Kimes and Goodfellow, 2005).

Another British-designed car, by J.P. Blatchley, and built by a British company, Bentley, the R-type was reserved exclusively for export. The Bentley was produced from 1952 to 1955, and embodied the two-door Fastback's graceful lines (Jennings, 2006), harmonizing streamlining to solidity, that would become a reference point in the brand design for fifty years. The R-type represented the difficult task of conveying two myths of the automobile at the same time: comfort and speed.

**Classic Bodies** | In the 1960s, sports cars would evolve with lower profiles, relating to the advances in architecture and aerodynamics, and reflecting developments in racing cars. Therefore, in the gap between the Jaguar XK and the E-type there were C and D types, originally designed to race. Both D and E types were designed by the aerodynamics specialist Malcolm Sayer to a high performance, and the result was an 'achingly gorgeous body', according to Jennings (2006).



**Figure 55: Jaguar E-type (1961).**

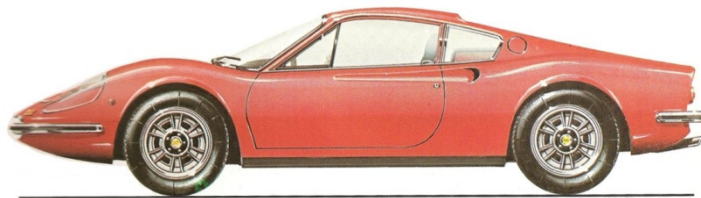
Gavin Conway (2007) points out that the car presented a 'marriage between performance and beauty that was once the sole province of Italian exotica. The E-type was a *looker*: a performer, an instant classic', 'the hottest tail in the automobile history, in one of the most erotic cars of all time', according to Paolo Tumminelli (2004). The car, to Stephen Bayley (2008), 'seemed to predict the democratization of pleasure that was the keynote address of the Sixties'. Although sex has been used to sell cars for at least a century, as Glancey (2003) observes, with the E-type the symbolism seemed to be driven to the extreme. According to Glancey (2003) the car can be an extension of someone's sexual ego, 'it has long been said that cars with long bonnets, like much maligned E-type, are penis extensions, or substitutes, or perhaps some men think this'. Nevertheless, women were attracted to the E-type too, as it somehow represented the ideal body, not a portrait of someone in particular, but an idealized portrayal.

The aesthetic of these organic shapes, muscular and sensual, related to classical ideals of human beauty found in ancient sculpture. Moreover, the Museum of Modern Art in New York made the E-type a contemporary sculpture, proving, for Bayley (2008), 'if proof were needed, that cars can be sublime works of art'. However, these cars' Classic Bodies not only represented this search for perfection in form, but also in function, and the bodies of these high performance sports cars became the athletes of the machine age.

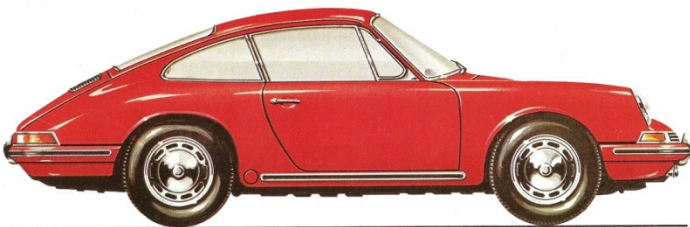
These Classic Bodies also took from motor sport their successful middle engine architecture. It appeared in the 1966 Lamborghini Miura, designed by the rising stars

Giorgetto Giugiaro and Marcello Gandini, at Carrozzeria Bertone. The Miura was the first mid-mounted supercar, designed after racing car principles (Holloway and Buckley, 2002). The car, considered one of the most beautiful of all time (Jennings, 2006), 'pushed the rivalry between Ferruccio Lamborghini and Enzo Ferrari to new heights', as Kacher notes. (2009b).

Ferrari's response came with the Dino (figure 56), designed at Carrozzeria Pininfarina by Leonardo Fioravanti (Edsall, 2008). Unlike those of the Miura, the Dino's body proportions expressed clearly its mid-engine architecture. Moreover, this architecture provided the car with a 'superb handling and a stunningly beautiful shape - one of design company Pininfarina's finest moments, according to Holloway and Buckley (2002). Thus, the Dino would influence all the following generations of mid-engine cars.



**Figure 56: Dino 206 (1967).**

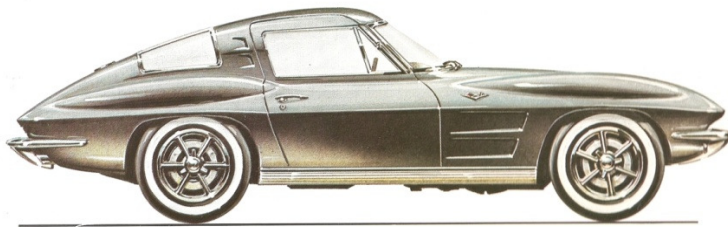


**Figure 57: Porsche 911 (1963).**

More loyal to its traditional rear-engine architecture, Porsche worked on a substitute for the 356, and created another Classic Body. The 911 (figure 57) was born from drawings made in the Fifties by Ferdinand Alexander Porsche, who was known by the family nickname, Butzi. For Butzi, who was trained at the Bauhaus in Ulm, 'styling doesn't exist to provide new faces. It must strive for what is truly good' (Bayley, 2008). Consequently, the 911 seemed more functional than erotic, showing a purely Darwinian approach to Classic Bodies. For Papanek (1984), 'the reason we enjoy things in nature is that we see an economy of means, simplicity, elegance and essential rightness there'. For Porsche, this

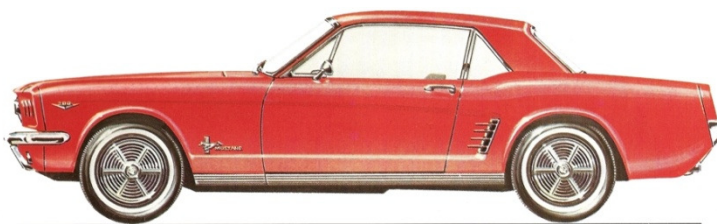
was how design should evolve. And so the company has been doing until today, with new versions of the 911 regularly released. Thus, the Classic bodies became an enduring reference in car beauty, often revisited, or in some cases, used as a starting point for a long genetic evolution.

In the USA, the Chevrolet Corvette, originally launched in 1953, following the Rocket trend, was replaced in 1963 by the model that was later known as the Sting Ray (figure 58). Responsibility for the design passed from Harley Earl to Bill Mitchell. The design mixed the voluptuous Classic Body with some well-defined edges, originating from fin-lines, creating interesting highlights. There was also the Sting Ray's famous *windsplit*, a subtle rib applied to the centre line of the car's hood and roof and dividing the rear window in two, a detail that related the car to the Bugatti Atlantic.



**Figure 58: Chevrolet Corvette Sting Ray (1963).**

**New Line** | Lines and highlights were defining new trends in the North American automobiles. According to Tumminelli (2004), the New Line started to establish a new aesthetic ideal for the modern car in the mid-1950s. 'A flatter and wide body with a lower centre of gravity promised to be more dynamic in a way that was supposed to have an effect not only optical but in performance. All metal surfaces were kept flat and straight: cars gradually became more horizontal and geometrical'. The beltline was clearly defined, emphasizing dynamism. When Ford released the Mustang (figure 59), a popular sports car conceived by Lee Iacocca with design by John Najjar, the archetype of the modern car was established.



**Figure 59: Ford Mustang (1964).**

**Edge Line** | The highlights evolved towards the edges, between flatter surfaces. The big North American sedans which had become too baroque, after the Rocket theme had been taken to its limit, were simplified to achieve more design clarity. The result was long and elegant lines, more orthogonal surfaces and less pictorial styling. Nonetheless, according to Tumminelli (2004), apart from modern lines and proportions, some cars were, in terms of design details, 'unnecessarily overworked'.

This was the case in the 1964 Buick Riviera and 1972 Lincoln Continental Mark IV (figure 60). According to Jennings (2006), the latter featured one of the most serious styling embarrassments of the time: the opera window on the C-pillar. These decorative elements were still part of North American taste, especially in luxury cars.



**Figure 60: Lincoln Continental Mark IV (1972).**

Together with the Edge Line, the Oldsmobile reintroduced the front-wheel drive to North American cars with its 1966 Tornado. This had been absent since the Cord 810 (Jennings, 2006). The car, designed by David North and Stan Wilen, is considered by Bayley (2008) to be the last great U.S. car.' The Tornado was the last 'personal' car: soon afterwards U.S. manufacturers lost their confidence in vulgar magnificence'.

The Edge Line cars sketched the basic profile of family sedans that would stand for at least 20 years, worldwide. The functional aspect of the Edge Line, often seen in European cars, developed its architecture with smaller wheels and more space for the interior; the front lights got considerably smaller, and later squared. At the same time, Edge Line design aimed for functionality, project precision and some room for decoration.



**Wedge Line** | According to Paolo Tumminelli (2004), 'the first radical break with the past occurred in 1968, the very same year as a cultural revolution hit society at large'. The decorative elements used to identify cars, especially the front-end, were reduced, due to their more aerodynamic shape, with a smaller frontal area. 'This undifferentiated look, with folding headlights, is the most democratic design feature ever produced: it meant the abolition of brand differentiation in terms of design' (Tumminelli, 2004).



**Figure 61:** *Il Carroziere Italiano* magazine cover with the Fissore Aruanda concept (1965)

This groundbreaking style came mainly from concepts developed by the Italian coachbuilders. Nevertheless, it is important to acknowledge the collaboration of designers from other parts of the world. The Brazilian Ari Antonio da Rocha developed a car design called Aruanda (meaning the rule of the mind over matter) when studying architecture at the University of São Paulo. After his graduation, he submitted the design to a contest at the local motor show. Among the jury were Pinin Farina, Luigi Segre and Bernardo Fissore. The Aruanda won the contest, and Ari Rocha a scholarship to a design masters course in Italy, and a job with Fissore. Later the car was built by Fissore, presented at the 1965 Turin Motor show, and shown on the cover of the main Italian coachbuilder's magazine (Castilho et al. 2006). Traces of the influential small two-seater Aruanda could be seen in the following year's concepts, for instance the 1966 Bertone Lamborghini Marzal greenhouse and graphics.

Another Wedge Line by Bertone, the Carabo (figure 63), appeared without the bourgeois chrome grill; the engine was moved to the middle of the car, in favour of aerodynamics, and with disregard for the symbolism of the long hood. Also in 1968, Giorgetto Giugiaro, who had started in Carrozzeria Bertone in 1959, replacing Franco Scaglione, launched the first concept of his independent studio, Italdesign. The Bizzarrini Manta concept (figure 62) was a revolutionary car not only in style, but also presented an innovative architecture: a mono-volume coupé, with one row of three seats and driver in the centre. (Molineri and Tumminelli, 2008)



**Figure 62: Italdesign Bizzarrini Manta concept (1968).**

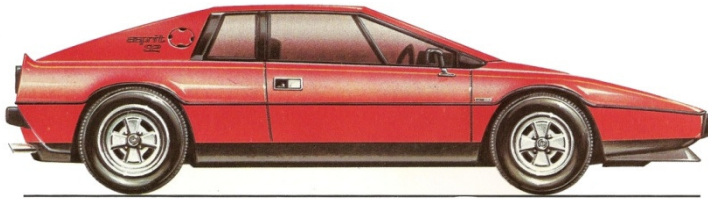


**Figure 63: Bertone Carabo Alfa Romeo 33 concept (1968).**

The trend soon reached production cars. In 1971 Lamborghini released the Countach, designed in Bertone by Marcello Gandini. During its 26 years of production, the unforgettable Wedge Lines of the Countach acquired a very strong image in the teenage boys' minds, with its famous posters replacing, or living side-by-side with pictures of pin-ups on their bedroom walls (Edsall, 2008). The car was only one metre tall, hardly a practical means of transport, but a true supercar, which according to Bayley (2008), 'might be ridiculous... but they are never boring'.

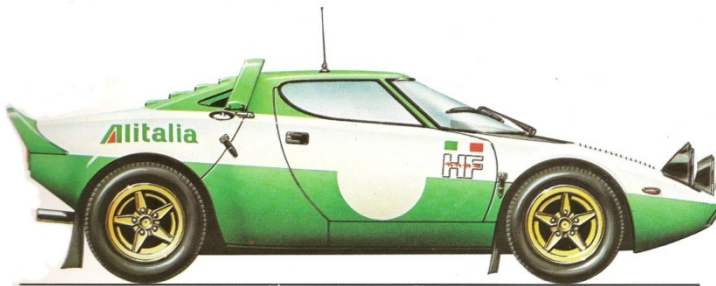


At the 1972 Turin Motor Show, Giugiaro presented Colin Chapman with a full scale-plaster model of his proposal for a Lotus supercar. Chapman approved the design and the Esprit (figure 64) was produced from 1976 until 2004, with few facelifts (Molineri, 1999). The longevity of the Wedge Line cars demonstrated how the style was ahead of its time. The minimalistic design of the Lotus Esprit did not lack the potential to create fantasy, and the car replaced the traditional Aston Martin in the 1977 James Bond movie, *The Spy Who Loved Me*.



**Figure 64: Lotus Esprit (1976).**

With more real capabilities road than the James Bond car, but no less able to evoke the myth of speed, there was the Lancia Stratos. The car was design by Gandini at Bertone, and built specially for rally competitions. The mid-engine architecture, with a Ferrari Dino V6, also proved very successful in rallies, and the car twice won the world championship. The Stratos (figure 65) became one of the most legendary racing cars of all time. 'The car was a favourite with the spectators, who loved its exotic noise and flamboyant shape' (Holloway and Buckley, 2002).



**Figure 65: Lancia Stratos (1973).**

Supercars had the most suitable architecture for the radical Wedge Line. Nevertheless, it influenced the design of other car archetypes too. It is possible to see Wedge Line principles in the 1977 Alfa Romeo Giulietta, the 1974 Lotus Elite, the 1976 Rover SD1 (Tumminelli, 2004), however, it started to become more boxy, rather than purely wedge.

**Flow Box** | The boxy style was, according to Tumminelli (2008), the confluence of the International Style and rational automobile aesthetics. The cars changed their proportions in favour of taller and more compact volumes, specially the popular cars. Cleaner surfaces also resulted in better aerodynamic performance and lower production costs. The angles between side panels, hood and roof produced a boxy shape, evoking rationality - in the context of the 1973 oil crises an important selling point. The Flow Boxes presented rounded, soft surfaces, together with a boxy volume. The surfaces were one with the windows, the bumpers and headlights were integrated without any breaks in the bodywork - all the irregularities were resolved.

The evolution of the Flow Box style can be seen in the evolution of the Porsche 928. The car, originally launched in 1978 (figure 66), blew away any doubts about the company's capabilities for innovation and whole-design development (Holloway and Buckley, 2002). The 928 was a V8 grand-touring sports coupé, revolutionary in every detail. (Weitmann and Steinemann, 1978)



**Figure 66: Porsche 928 (1978).**

The all-in-one shape integrated flexible bumpers, without any interruption to the surface. To save weight, there were several different materials in the body, from plastic bumpers to steel wings and aluminium alloy doors. The architecture of the car was meticulously designed to achieve a perfect equal distribution of weight through the wheels. Because of this, the gearbox was placed in the rear axle. The car was the first car with 'self-steering' rear wheels, to improve stability (Holloway and Buckley, 2002). With all this innovation, the Porsche 928 was selected as 1978 European Car of The Year - the one and only in the history of the brand, and also the only sports car ever awarded by the contest. Nevertheless, the car was never a market success, and did not replace the 911, as initially planned by Porsche (Beckley and Rees, 2006). On the other hand, the 928 became a designer's favourite. Some, like Simon Cox, were inspired by the sculptural shape designed by Anatole Lapin (Newbury and Lewin, 2008), some were amazed to acknowledge the

result that was possible through a whole-design process. During the 18 years that the Porsche 928 was produced, the basic body was kept the same. In the later S4, GT and GTS models, the bumpers and lights were redesigned with more rounded shapes. The facelifts progressively erased most of the edges common to Flow Box styles of the 1970s and 1980s. The straight lines and very defined geometry, typical of the 1970s, saved the car from the 'vanilla design' that contaminated the Flow Box in the 1990s (Tumminelli, 2004).

**Edge Box** | Less smooth than the Flow Box, the Edge Box style appeared after the 1973 oil crisis in many new compact cars. The experimental and production cars designed by Giorgetto Giugiaro played a decisive influential role. His 1978 Lancia Megagamma concept was 'the inspiration for an entire generation of station wagons' (Tumminelli, 2004). Moreover, his 1974 Volkswagen Golf (figure 67) synthesised the 20th century's benchmark for the popular automobile. Considered by Rich Taylor to be a contemporary master of art (Bayley, 2008), the Italian designer created some of the most successful and influential cars of the second age of car design.

*'Giugiaro handled plastic volumes better than any Italian since Michelangelo'. (Richard Taylor, 1978).*



**Figure 67: Giugiaro's drawing of the Volkswagen Golf.**

Giorgetto Giugiaro came from a fine art and rendering background to work with Dante Giacosa at Fiat, moved later to Carrozzeria Bertone and finally to his own company, Italdesign, always looking for more freedom to further his ideas (Molineri, 1999). The Golf was the second car designed by Giugiaro after leaving Bertone (Bayley, 2008). The new Volkswagen came to replace the ubiquitous but totally outdated Beetle. According to Bayley (2008), it was 'a late-flowering commitment to modernism and to new technology. It was a German take on Alec Issigonis' Mini formula, but executed with more precision

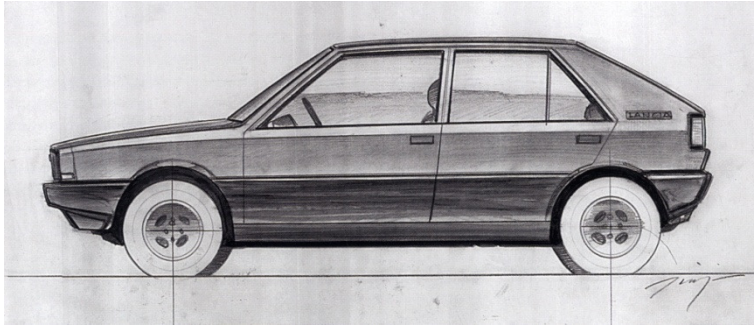
and harder edges'. Bayley (2008) remembered that 'like all excellent designs, the Golf is capable of development: five model cycles had not departed from the original proposition'. Moreover, the new generations of the Golf demonstrated an assimilation of the genetic evolution of the popular car, and continued to be considered the best in the category for more than 30 years. The question to be asked of Volkswagen is how one of the best cars of the Evolutionary Age will adapt to the Age of Sustainability.

The car was also produced in the USA as the Volkswagen Rabbit, and in its early years gained a tuned version, the GTI. This compact car, with high performance, provided speed for the people. With the Golf and Rabbit GTI versions, having a Volkswagen was no longer just about gaining freedom; the package provided one of the best dynamics of all time (Smith, 2007).

The trend of tuning compact or family cars gained strength while the effects of the oil crisis started to diminish. Intelligent packing and architecture gained more priority, and there were some provocative design additions. Sudjic (2008) observes that the use of red on black was 'a striking motif - one that entered the visual consciousness of designers, who always work by manipulating and recycling imagery from multiple sources'. Thus, this colour combination was used on the radiator grill of the Golf GTI: black with a narrow red line frame. The same trick was applied by BMW on the bumpers and interior of its tuned M3.

**Graphics** | Graphics gained importance in the Edge Box style, through decorative elements and rational engineering. The extensive use of plastic, without paint, to save weight, configured a new colour combination in these designs. The most distinctive feature was the integrated bumpers, in dark grey plastic, appearing in many popular cars. Giugiaro's FIAT Uno and Panda made them omnipresent. Soon this solution was adopted by almost everyone: they were on cars ranging from Mercedes-Benz to Alfa Romeo; and expanded from European borders throughout the whole world. (Tumminelli, 2004)

Giugiaro, who experimented with the graphic potential of plastics from the 1960s, was again a master of the trend. He used these plastics to enhance line and character, or to lighten volume. Giugiaro's original drawings for the Lancia Delta (figure 68) showed the lower part of the body and bumpers in plastic. However, in common with most other cars at this time, the plastic parts began to be painted, a departure which not only hid their functional style, but complicated production, use, maintenance and recycling.



**Figure 68: Giugiaro's drawing of the Lancia Delta.**

In its tuned rally version, the Lancia Delta came to replace the Stratus as world champion. The car that proved the efficiency of four-wheel drive architecture is also remembered for its long name, Lancia Delta HF Integrale 16v Evoluzione II, in one of the latest versions. Lancia was literally trying to show its dedication in developing the car. Furthermore, as Holloway and Buckley (2002) have stated, the car was perhaps the ultimate in 'hot hatchbacks', and one of the greatest driver's cars of all time.

**Sportiness** | The last decades of the 20th century were motor sport's golden years, that helped to support the myth of speed and the development of more powerful, faster cars. In the rally context, the Lancia Delta and the Audi Quattro (figure 69) not only achieved amazing results but help to develop all-wheel drive systems that enabled the transfer of an enormous amount of power to the road with more safety. The 1983 Audi Quattro was one of the most innovative cars of its time (Sherman, 2007) and became a landmark in car history, having introduced the four-wheel drive to road cars (Holloway and Buckley, 2002). Together with their performance, these cars presented a masculine look, with large exposed shoulders to fit bigger tyres, spoilers, and skirts. However, these features were also used indiscriminately on low-performance popular cars to create a more sporty look.



**Figure 69: Audi Quattro rally car (1983).**



Traditionally associated with Audi, Porsche took their four-wheel drive technology to the 911 and won the famous Paris-Dakar rally in 1984, and again in 1986, with the 959. Also, having led the field of turbo engines in production cars from the 1970s with the 911 Turbo, Porsche turned to Formula 1 and supplied engines for McLaren to win world championships with Niki Lauda and Alain Prost. (Porsche, 2009)

In 1988, the last year of the turbo age in Formula 1, the Brazilian driver Ayrton Senna won the championship with McLaren - now powered by Honda engines. The car was one of the most successful racing cars of all time, winning 15 of the 16 races of the season. The year after, Ferrari introduced the semi-automatic gearbox, with paddles to change gear on the steering wheel. From that moment on, electronics began to assist driving, and in people's imagination racing did not offer pure evidence of the drivers' skills anymore. Prost, at that time with Ferrari, came close to the title in 1990, but was defeated by Senna again. Nevertheless, his Ferrari 641 F1-90 became famous not only for its performance but also because of its looks. The curved shape and clean surface attracted the attention of art curators, and the car joined the Cisitalia 202 at the MoMA collection. (Chapman, 2007)



**Figure 70: Senna's McLaren and Prost's Ferrari racing cars (1990).**

In the following years, the importance of electronics in Formula 1 increased. The 1991 Williams FW14 forged ahead of the competition, with active suspension, semi-automatic gearbox, traction control and anti-lock brakes. However, Ayrton Senna, with a less advanced McLaren, conquered the world championship again, in a battle of man against electronics. Symbolically, Senna's triumph was the celebration of human skills against artificial intelligence. Whilst that was the last time a racing car provided a pure connection between driver and road – 'pure' meaning that the connection was without electronic filters - Senna has been acknowledged as the last great Formula 1 driver.

The same dichotomy was seen in supercars of the time. In 1987, Porsche introduced the 959, built initially with the intention of becoming a Group B racing car. The supercar came

with permanent four-wheel drive and computer-controlled traction-control, and a luxury interior. The car was produced as a limited edition, like its competitor, the Ferrari F40 (figure 71). Built to celebrate the 40 years of the brand, the Ferrari supercar was designed as a racing car for the road. To save weight, the Ferrari F40's 'interior was utterly devoid of carpets and door trim', and the bodywork used lighter, composite materials. 'The fact that the cockpit was sparsely trimmed was a positive point, and the sight of a carbon fibre and exposed tubing was a delight, not a penance. It meant that being inside an F40 was an extremely noisy experience but given the sound - as close to a racing engine as you could get - that was also part of what made the F40 so unique. It was very focused and technically advanced, but not the technological *tour de force* that the Porsche 959 was. Rather it was a car for the enthusiast'. (Buckley and Rees, 2006)



**Figure 71: Ferrari F40 (1987).**

The F40 was designed by Pininfarina, combining sportiness and elegance, subtle sensual curvy lines and strength. It was the last car developed by Ferrari 'under the watchful eye' of Enzo Ferrari. *'Il Commendatore* wanted to show the world that Ferrari could still build the best sports car on the planet' (Noordeloos, 2007). Ferrari made one of the most iconic cars of all time, the epitome of the myth of speed, in its purest experience. If the distinction between art and design is usability, the F40 was a work of art, with regard to all the symbolism and fantasy that this should encompass.

**Sport Utility Vehicle** | Sport Utility Vehicles can be considered a typology rather than a style, and SUV is indeed, a denomination for a class of vehicles. Although vehicles of this class could have made use of many different design languages, either being more Edge Box, like the 1984 Jeep Cherokee and the extreme 1982 Lamborghini LM002; or Flow Box, like the 1970 Range Rover, the most significant aspect of its aesthetic is, however, a consequence of the typology, the market it created and the use it has had.

The typology evolved from the North American pickup trucks, mixing a cross-country vehicle with a station wagon. According to Tumminelli (2004), the 1963 Jeep Wagoneer was the forerunner of the SUV category. The idea of adding more comfort to an off-road vehicle was later explored by British designers, too. The Range Rover 'made utility chic; a piece of agricultural equipment was consumerized into an attractive package' (Bayley, 2008). The Range Rover was designed by David Bache and maintained a functional language, with its parallel lines and distinguishable parts - hood, roof, and pillars.

The breakthrough in this category came later in the 1980s with the Jeep Cherokee. The 1984 model (figure 72) was the first one built in a unibody construction rather than with a body-on-frame architecture (Macey and Wardle, 2008). The Jeep became a market success worldwide. However, while the SUVs were condemned in Europe for being too big for cities, in the North American context of trucks and big cars, they were seen as small vehicles.



**Figure 72: Jeep Cherokee (1984).**

According to McCarthy (2007), 'the relationship between Americans and automobiles over the last two decades of the twentieth century proved quite different than that predicted in 1980. The future belonged, not to the small car, but to big cars - very big cars - or, more precisely, light trucks.' Thus, at the end of the 1990s half of the vehicles sold in the USA were light trucks (including pickups, minivans and SUVs). 'But this revolution in consumer tastes had its consequences. When millions replaced their cars with light trucks, progress toward improving the safety, cleanliness, and fuel efficiency of American motor vehicles began to slow down and, by some measures, was reversed. Americans who had grown up listening to Ralph Nader crusading for safer automobiles, who knew that automobiles caused smog, and who lived through the energy crisis in the 1970s, certainly understood that larger, heavier vehicles burned more gasoline and posed a threat to smaller, lighter vehicles in collisions.' (McCarthy, 2007)



Although the optimism around cheaper oil prices is not enough to explain the enormous growth of this niche market, the change in taste related to people's aesthetic experience with SUVs is also important. McCarthy (2007) remembered that there was no special marketing magic behind the light truck boom. 'The companies had always marketed pickups and SUVs in a manner that appealed to a variety of needs, including off-road recreation and suburban living'. However, while the consumer was buying a vehicle and the illusion of a weekend escape or a lifestyle change, research suggested that no more than 10 per cent were actually driven off-road. The car makers understood this, and soon provided the market with more SUVs without four-wheel drive but with more luxury. The names of the vehicles evoke masculine imagery: Bronco, Blazer, Range Rover, Trooper, Pathfinder, Cherokee, Explorer. However, a high percentage of the SUVs were driven by women. In a context where vehicles were growing bigger, many families chose the SUV as an ideal vehicle to carry their babies, and protect them from the pickup trucks and other SUVs. Whilst in the USA, pickup trucks were always the best-selling vehicle, the SUV has taken over in the family car market, resulting in an overall growth in the average size of the vehicles, with a huge environmental impact.



**Figure 73: Porsche Cayenne (2008).**

According to the Stanford cultural anthropologist Sarah Jain, the SUV represented 'the inability of Americans to make a connection between consumption decisions and their social impact' (McCarthy, 2007). The acceptance of the SUV signified that individuals were still avoiding their own responsibility to society and the environment, and tended to make decisions based on what they understood as their immediate desires and necessities. All over the world, the boom of the SUV arrived selling the illusion of safety and fun, and fed the myths of comfort and freedom, respectively. The search for bigger and stronger vehicles could also be seen as a response to violence and terrorism threats, which progressively increased their significance in people's imagination, and in some countries, in reality too.

In the following decades, the SUV would be at the centre of the debate about climate change and quality of the urban environment, and came to be considered as the biggest evil of the auto industry. Nevertheless, their impact on the market did not cease to increase significantly. The SUV typology expanded in many different directions. Luxury SUVs came from Mercedes-Benz, BMW and Cadillac; and high-performance cars from Porsche (figure 73). Smaller and cheaper models were also developed by Ford, Volkswagen, Nissan, Suzuki, Peugeot, and many others. With all this diversity, the SUV fulfilled both the aspirations and budget of many more consumers. According to McCarthy (2007), the boom in the SUV showed that most Americans - and not only them - 'were still not much concerned with the environmental impact of the automobile in any case. History suggested that it would take far longer than knowledge of the problems to change any of this any time soon'.

**Feminine** | In the beginning of the 1990s, the importance of women as buyers leaned towards the development of specific trends expected to suit women's tastes. The Nissan Figaro was designed to suggest that it belonged to another time, to look as innocent as a toy, sophisticated, funny and fashionable. Altogether, the trend was a counterpoint to the inborn testosterone of Sportiness and SUVs. 'Renault quickly followed, giving the Twingo (figure 74) its cute, anthropomorphic look' (Sudjic, 2008). The small Renault was innovative in its use of space. However, together with this functionality it had a frog-like face, to appeal to the consumer's emotions, too. Many Japanese and European brands followed the trend. Anthropomorphic design elements were featured in the Opel Corsa of the time, and, with a little feline touch, in the sportive Tigra. (Tumminelli, 2004)



**Figure 74: Renault Twingo (1993).**

**MPV** | Renault also had a team of female designers to work on concept cars. From this design team came the idea of the future small people-carrier vehicle that every manufacturer would try to copy, the 1996 Renault Mégane Scenic (figure 75). The car was a 'hit from the moment it entered the marketplace, and it redefined the family car. It's

worth remembering that the overall champion of this architecture was Giorgetto Giugiaro, who has championed the idea longer than anyone now active in the industry' (Cumberford, 2005).



**Figure 75: Renault Mégane Scenic (1996).**

This class of cars came to be known as MPVs, a denomination first used by Mazda in 1988 (Chapman, 2007). Like the SUVs, in the case of the MPVs the new typology was a more important trend than the styles it had followed. Basically, all the carmakers who launched MPVs were trying to fit their own design language to a small people-carrier. The MPV, has nevertheless, set a new standard of comfort, with a more dynamic interior, raised seating position and great view to the outside.

**Retro** | In the beginning of the 1990s there were important style trends, too. One of the most significant, according to Cumberford (2005), was the nostalgic lines of Retro cars. It started with the 1989 Mazda Miata, which brought back the small and relatively cheap roadster layout. The car was a revival of the British MG in concept and style, and turned out to be a success, proving that the consumer wanted more emotional designs. The car became a cult vehicle, and inspired a Retro wave in car design that would continue for at least two more two decades (Tumminelli, 2004).

The North American designer J Mays, together with Freeman Thomas, created a revival of the iconic Beetle, but using a Golf platform. Thus, the New Beetle (figure 77) has presented conflicting package. The front-mounted engine pushed the passenger compartment backwards, and the rear seats have very little headroom. Martin Winterkorn, CEO of Volkswagen Group, has recently asserted that the architecture must be reviewed: 'The front-wheel-drive layout makes it difficult to get the proportions and the package spot-on. That's why I would like to experiment a bit with the position of the engine' (Jennings, 2007b). The styling intention is not coherent with the architecture, and in a deeper analysis the aesthetic is meaningless and inadequate. The New Beetle is a case

of design developed without a complete understanding, and aesthetic concerns are nothing more than a effect in the visual interface of the object, literally and symbolically: superficial aesthetics.

J Mays also brought his 'retrofuturist' philosophy to Ford, creating the new Mustang and the new Ford GT, that might seen, according to Tumminelli (2004), as a Remake. This car explains why Mays has been criticized for concealing the 'futurist' aspect of his style. (Edsall, 2008).



**Figure 76: BMW Mini (2002).**

Another North American designer, Frank Stephenson, reinterpreted another European icon, and redesigned the Mini (figure 76) in a bigger and more expensive version, to be built by BMW - the current owners of the brand. Fiat also came with a Retro -styled new 500. In the marketplace, these cars were very successful, but after some time, the criticism about Retro design began to increase. In 2007, Robert Cumberford wrote in the editorial of the issue of *Auto & Design* magazine reporting the launch of the Fiat 500, that 'nostalgia has its limits'. According to him, 'there are entirely too many vehicles around today that recapitulate the flaws as well the virtues of the past'. Some cars, like the Chrysler PT Cruiser and the Volkswagen New Beetle, compromised their internal volume heavily in favour of a design language. 'Of course, space efficiency is not the be all and end all of vehicle design.(...) Above all, though affective charm matters most in enticing costumers. (...) What the new Mini demonstrated to the world is that being alluring to costumers allows pricing well above the cost of manufacture.' (Cumberford, 2007b)

Cumberford (2009f) also acknowledged that the new Mini and the Fiat 500 looked more like expensive products than popular or innovative ones, especially when compared to their originals. The trend might have helped the industry to rise in difficult times, but seemed to limit the creativity of designers to work as imitators of old models and not give room for the aesthetics to evolve along with technology and society.

*'The past has passed. Let it lie, and start something new and wonderful.'*  
(Cumberford,2007a)



**Figure 77: Golf blueprint over the New Beetle.**

**Geometrical** | Together with the Retro style, the New Beetle also showed lines defining a clear geometric shape. The same language was used on the Audi TT design (figure 78), a collaboration between Freeman and Peter Schreyer (Edsall, 2008). The compact Audi sports car was a pinnacle of Volkswagen's philosophy of sharing platforms. Like the New Beetle, the TT was based on the Golf floor plan, and like the Audi A6, the TT presented 'a very distinctive shape' that was described by Holloway and Buckley (2002) as 'a kind of machined modernism'.



**Figure 78: Audi TT (1998).**

Peter Schreyer, a graduate from the Royal College of Art, searched for references to a pre-war German industrial design aesthetic. Together with a Bauhaus design philosophy, Audi concepts reinterpreted the clean surfaces of the pre-war Auto Unions. The result was first

seen in the 1996 Audi A6. The car's 'futuristic rump, with narrow lamp clusters mounted on each corner of the tail and heavily curved roof pillars, was both modern and reminiscent of art deco and ocean-liner style', according to Holloway and Buckley (2002). Moreover, Audi's design showed that was possible to both refer to the past and also amaze, without losing rationality.

**Smooth Body** | Paolo Tumminelli (2004) considered the Audi TT as a Smooth Body car, a trend that was the successor to the Flow Line and Flow Box, presenting 'clean lines, elegant looks and an aerodynamic feel. Nevertheless, Audi's design language was at the extreme of clear geometry, while at the other end there were the 'vanilla' designs, previously mentioned. The Smooth Body designs had organic shapes and curved surfaces that, when overworked with round lines, led to an exaggerated softness in style, known as Vanilla Design. The cars that followed this extreme of the trend didn't last long, as expected for a radically fashionable product. The case of the streamlined GM EV1 (figure 79), however, is not enough to explain the early death of the electric car.



**Figure 79. GM EV1 (1996).**

**New Edge Box** | According to Tumminelli (2004), as a reaction to the 'characterless Vanilla styles', in the late 1990s a new repertoire of design details was developed to create more an interesting language. Straight lines and sharp angles were added to give personality to smooth bodies and flow boxes. The trend was set by Ford models, like the 1996 Ka and 1998 Focus, and was quickly followed by almost every manufacturer. The use of unexpected angles, seen in the side profile of the Mercedes Benz A-Class (figure 80), resulted in a Deconstructivist appearance. (Tumminelli, 2004).





**Figure 80: Mercedes Benz A-Class (1997).**

The small Mercedes A-Class established the mono-volume for good. For Mercedes, it also presented the challenge of maintaining the brand's paradigm of comfort and safety in a supermini package. To get around this, Mercedes designed a double-decker floorplan' that would hold the engine under passengers' feet, in the case of a front-on collision (Holloway and Buckley, 2002). Moreover, the new architecture gave the A-Class extraordinary interior space, and suggested interesting perspectives to the development of alternative powertrains, such as the battery -electric or fuel cell. According to Holloway and Buckley (2002), 'the A-class was - like the Austin Mini when it was launched in the 1950s - the shape of future European motoring, and one of the most significant cars ever made'.

**Carved Body** | The continuing investigation of the expression of straight lines and sharp angles led to 'flaming surfaces' and Carved Bodies. According to Tumminelli (2008), in the latest trends of the Evolutionary Age, the car was generally viewed as a body. The sophisticated surfaces, developed with computer-aided design, were integrated, creating a complex unitary form.

Similar processes occurred in other design disciplines, like architecture, where software helped to design and engineer buildings with an innovative language of form. In architecture, the works of Frank Gehry, Peter Eisenman, Daniel Libeskind, Zaha Hadid and Rem Koolhaas showed an aesthetic that developed from Postmodernism through ideas of fragmentation and complexity that led to Deconstructivism. In car design, the work of Chris Bangle as head of BMW's design presented a consonance to Deconstructivism in lines, shapes and some principles. In Bangle's designs, as Philip Johnson and Mark Wigley (1988) noted in Deconstructivist architecture, the dream of a pure form has been disturbed, showing a different sensibility.



**Figure 81: Zaha Hadid installation at Venice Architecture Biennale (2008).**



**Figure 82: BMW GINA Light Concept (2008).**

As Gehry and Hadid had done, Bangle still made use of physical models to develop his ideas (figures 81 and 82). The most important of these was the concept car used internally at BMW as inspiration to the new design language, the GINA Light, only unveiled in 2008. The car body was created using flexible materials, structured to a skin skeleton with the ability to move and change its surfaces, that themselves were a surprising combination of concave, convex and unexpected edges. Bangle declared: 'The important thing is to start questioning dogmas: and sometimes you need a big hammer to break them down. The GINA philosophy, in its short form, is about being flexible - thinking flexible, acting flexible - context over dogma, that's it'. (Galvano, 2008b)

Returning to production cars, Bangle was able to change the traditional BMW language, established 40 years earlier by Paul Bracq (Bayley, 2008). The 2003 BMW 5-series (figure 83), one of Bangle's best designs, presented a carved body with very controversial detailing. According to Bayley (2008), in the conservative world of car design, 'this was a disruption that may be compared to Picasso's creation of cubism'.





**Figure 83: BMW 5-series (2003).**

In the BMW, the lines had lightness and dynamism, that caused the style to be known also as 'flaming surfaces'. With different characteristics, nevertheless, the Carved Bodies were everywhere. Sometimes they appeared in Cubist compositions, like the 1999 Renault Avantime; sometimes they were more well-behaved, like the 2009 Ferrari California. (Tumminelli, 2004).

**Edge Body** | As the Carved Body, the Edge Body also explored highlights and edges of surfaces. The difference was the basic dominance of convexity and sharper straight lines that made the look of the Edge Body imposing and solid. The trend was a natural evolution to the Wedge Line, and appeared on the new Lamborghini line, and designs by Giugiaro. It was also an evolution of Edge Line and Flow Box, bearing some resemblance to long-gone fins, but still important as a reference to North American car design. Thus, Lincoln, Cadillac (figure 84) and Chrysler were among the carmakers that followed the trend.



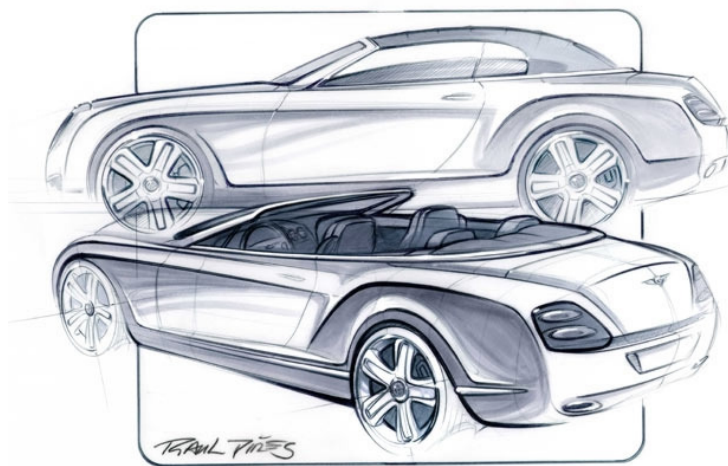
**Figure 84: Cadillac STS (2005).**

In Cadillac, the British designer Simon Cox, another graduate from the Royal College of Art, was responsible for developing a style that was very consonant with the North

American tradition. According to Newbury and Lewin (2008), Cox's Cadillacs were 'a far cry from the flashy, finned monsters of US movie legend. But with their sharply chiselled features, intricate angles and big road presence, they were no less impressive (and no less American) in their style.'

**New Classic** | Cox tried to bring Cadillac back to its original, or most famous, language. Nevertheless, he did it without being Retro. Tumminelli (2004) points out that when classical elements were interpreted in a new way, so that on the one hand they appeared unmistakably traditional, and on the other hand proved very up-to-date due to new proportions and innovative details, a New Classic design was made.

Moreover, a parallel could be identified between this trend and Postmodernism. According to Jencks (1977), the postmodern combines two codices, one that is 'popular, traditional and evolves slowly, like a living language, full of clichés and rooted in family life, and one that is modern, full of new images and fast changes in technology, art and fashion'. The same double codex was demonstrated in the New Classic style, where Retro was basically supported by styling intentions regardless of zeitgeist engineering and aesthetics.



**Figure 85: Raul Pires drawings of the Bentley Continental GT.**

New Classic design was a favourite of prestigious brands, either to keep their status or regain it. European companies, particularly, used the approach in the battle with Japanese manufacturers. New Classic was the resurrecting trend of British brands like Aston Martin, Bentley and Rolls-Royce, all of which were then controlled by non-British companies. And again, traditional design was not necessarily rediscovered by local designers. The Bentley

Continental GT (figure 85), considered by Jennings (2006) a masterwork of its time, was designed by a Brazilian, Raul Pires. The designer found his inspiration on the fender lines and streamlined tail of the 1953 model. Furthermore, the profile and volume showed influences from the Cisitalia 202, the description of which, by Nahum (2009), might be applied also to the new Continental GT: 'The wheel arches' wings have a powerful animalistic quality, evoking the front paws and rear haunches of a leopard at rest and speaking to some subconscious archetype of power and drive'.

The Continental GT, developed by Bentley as part of the Volkswagen Group, 'was one of the success stories of the economic boom of the first decade of the new century. The means by which the new owners managed to build a series of models that appeared to be inheritors of all the virtues of the Bentley name is a triumph of manipulative brilliance', according to Sudjic (2008).

Ferdinand Piëch's philosophy of sharing platforms, once again, helped to create the possibility of producing a luxury car that did not have to count on large volumes of production to amortize the investment for its development. Sudjic (2008) added that 'Bentley's solution with the Continental was to develop forms that made the most of its strengths in panel-beating. They make possible a distinctive body with the personality of a Bentley. The result is a car that suggests that it might belong to the past, without actually looking old.' Nevertheless, the success of the New Classic created the illusion that adding some clichés, design clues and elements from renamed icons of the past was enough to make good design. This mannerism led to bizarre results, when Aston Martin miniaturized their sports car, attaching the brand's famous grill to a small Toyota IQ.

**Individualism** | Another significant trend of the turn of the century was Individualism, but not the sort brought about by the fear of isolation in the virtual world. This design trend created designs which aimed to disguise the automobile's function as a family car, giving the consumer the impression of being a two-seater, sports cars or GT.

The Italian designer Walter de'Silva developed this idea for the 1997 Alfa Romeo 156, in relation 'to that (technical and aesthetic) category of sportiness which historically and immutably seemed to be linked to the very image of the Arese company', according to Felicioli (1998a). To make a family car resemble a GT, de'Silva raised the beltline, giving the body more visual weight than the windows, and concealed the fact that the car was a four-door model by using hidden door handles. Thus, even the station wagon looked like a driver's car, and resulted in the name 'Sportwagon'. Moreover, Felicioli (1998a) stated

that 'the Alfa 156 is the result of a design operation which is extremely well-thought out and refined, which has succeeded in harmonizing the tough strength typical of a coupé with the lightness and almost feminine grace of an elegant and sophisticated saloon'. The 156 made de' Silva one of the most influential names in car design of its time.



**Figure 86: Alfa Romeo 156 Sportwagon (1997).**

Individualism also helped to create a new class of car, the unpredictable four-door coupé, that could be seen as offering the best of both worlds, or the worst. In one case, the mix was effected by Mercedes-Benz with the CLS, designed by Peter Pfeiffer (Jennings, 2006). The principle was to give a sporty look to the four-door, combining the myths of comfort and speed; however, there were drawbacks. The roof was lowered and the beltline raised, compromising both headroom and visibility. The claustrophobic interior might not have been a problem but something the customer actually wanted in these vehicles; however, the performance was compromised by the size and weight of the cars, that grew too long to fit spacious interiors. The solution was to use more powerful engines, a *more is more* philosophy, that survived well into the beginning of the 21st Century, and spread to other premium brands.

**Grotesque** | Together, Individualism, Edge Body, the SUV, gangster rap, terrorist threats, virtual reality games and virtual living were creating the context of the first decade of the century. The epitome of its aesthetics was probably a vehicle, the Hummer. It was a strong sign of stress in creativity and lack of principles in the car industry, in spite of the fact that it matched the expectations of some customers.

The concept was not new: like the Jeep, the Hummer was based on a North American military vehicle, the High Mobility Multipurpose Wheeled Vehicle (HUMVEE). However, the size of the new vehicle, developed by GM, was enormous, and inappropriate for civilian use. The impact on the streets was frightful. The design was intended to cause fear to others. After getting the licence to produce the civilian Hummer, GM progressively

downsized it from the H1 model to the H3 (figure 87), and refined its style, but without losing its Grotesque aesthetics.



**Figure 87. Hummer H3 and VW Polo in the streets of London.**

The Grotesque didn't start with the Hummer, but rather at the end of the millennium, when a number of animalistic designs appeared, especially in big cars, trucks and SUVs. According to Robert Cumberford (2008b), back in 1986, Chrysler's designer Bob Marcks sketched out the idea of a 'tough big rig' look, to transform the sales of Dodge pickup vehicles. The result came at the 1993 Detroit Motor Show, with the Ram. The aggressive styling tripled the sales of Dodge's pickups in the USA, and at one point the sales of the Ram were only just behind those of the enduring best-selling vehicles, the Ford F-150 and the Chevrolet Silverado.

While to GM the expression of the Grotesque was full of edges, providing a man-made machine aesthetic, in the Dodge line the Grotesque was characterized by aggressive animal shapes, with strong, organic form. Both versions of the trend were scaled down to influence other vehicles, such as the Dodge Viper sports car. However, the most frightening aspects of the Grotesque were seen in the pickups and SUVs.

**Minimalism** | In opposition to the waste and oppression of the Grotesque, Minimalism appeared as a trend in cars conceived by focusing on lower environmental and urban impacts. As a style, Minimalism could be related to the cleaner examples of Smooth Body and Geometrical; however, in taking the 'less is more' philosophy to the whole design concept, it represented an effort to develop more rational vehicles for the city. Cars of the Minimalist trend generally presented innovative architecture, advanced technology to save fuel and functionality, together with a design language that would inform its good intentions.



**Figure 88: Audi A2 (1999).**

The aerodynamic 1999 Audi A2 (figure 88), with reduced dimensions and weight, was an early example of the trend. Moreover, as said before, the geometry of its K-tail was enhanced by its clean shape, ideas that were followed in another Minimalist car, the 2004 Toyota Prius. To reduce fuel consumption and emissions, Toyota chose to develop the hybrid powertrain. According to Nahum (2009), 'the Prius is a technological *tour de force*, though its great success in locations such as London and California has been helped by favourable tax or charging regimes'. However, Cumberland (2006) notes that in California, the Prius was bought by many Hollywood celebrities, who wanted their public image to be associated with a car that was both eco-friendly and beautiful.



**Figure 89: Toyota Prius (2004).**

The Toyota Prius (figure 89) is the subject of one of the case studies in this research, as is another car from the same trend, the Smart Fortwo (figure 90). Minimalism, to Smart, was more about an attitude than a design language, with the plurality of the Swatch style being kept in the language. This was one reason that the car was seen more as a consumer product than an automobile (Bayley, 2008). The other reason was because the Smart was created to provide the benefit the consumer wanted from it, and didn't follow the direction of contemporary car design.



According to Nahum (2009), Smart paid the penalty of reopening the sub-Mini sector as a mainstream company. As the first two-seater produced for a long time, but not at a lower price than some four-seaters, Smart struggled in the market. But as Bayley (2008) remarks, 'eventually the extraordinary convenience and charm of the car won the sceptics over. Consumers enjoyed its strange mixture of eccentricity and very high levels of physical quality'.

Minimalism is one of the last trends of the current age of car design, and the one most strongly linked to the development of the trends of the next age, the Age of Sustainability. The Evolutionary Age presented many different trends, more and less creative designs, and, certainly, some icons and great cars to be remembered and celebrated. Strong references also imprisoned car design in its cage of introversion. Moreover, the changes in context, especially the urgency of creating a more sustainable future, respecting people, the quality of life in cities and the environment, has resulted in a stress point in car design, as it has developed up to today. In the next age, more ecological designs, like the Smart, will change aesthetics.

*'The great age of car design is over or, at least, its assumptions have changed. The most significant car of recent years has been the modest Smart, an inheritor of the culture of Germany's Kleinwagen.'* (Stephen Bayley, 2008)



Figure 90: Smart Fortwo in the streets of New York.

### 2.2.5. The Age of Sustainability

There is not a fixed date to the start of the Age of Sustainability. The 2008 credit crunch has had devastating effects on the car industry. The American 'big three' - Ford, Chrysler and GM -were seriously affected. Ford was the only one of the three that maintained its independence, surviving without a bail-out. Chrysler ended up in the hands of Fiat. GM basically relinquished control to Barack Obama's government. The fall of this great American giant could be considered the Pruitt-Igoe of the Evolutionary Age. The bankruptcy of GM was also associated with bad product development, and in order to recover, a number of GM brands were terminated, among them, significantly, being Hummer. Along with this the company developed a commitment to focus on more economic and ecological cars, significantly the electric Chevrolet Volt.

Moreover, bail-outs, acquisitions, cuts in portfolios and personnel were only a kind of medicine to avoid bigger structural changes. The response from the industry in the first motor shows after the crisis was a mix of realism and hedonism, according to Fulvio Cinti (2009). The concept cars developed through more sustainable principles became dominant, but immediate alternative solutions were absent, and a lot of overworked older models exposed the real weakness of their product development. The shows appeared more to be the last of an age than the first of a coming one. There was not a paradigm shift yet. Fulvio Cinti wrote in the editorial of the *Auto & Design* magazine (05.2009), that 'a more decisive response would have been out of question. The recovery will be slow and arduous. But against the backdrop of these troubled times, there is another drama unfolding with car design at its centre. A game of musical chairs has begun. Could this be a sign of a desire to reinvent the car at all levels, including its architecture and aesthetic?'

As world's leading designers were asked to react, Giorgetto Giugiaro observed that 'there are many problems, but our society will never relinquish individual mobility. Often, what might seem like problems prove to be stimuli for research into new ideas and sparks igniting change: think of the petroleum crisis, for instance, which has spawned and will continue to encourage the development of hybrid powertrains and alternative drive systems.' (Cumberford, 2009a). Recently, Giugiaro's company, like many others, has been presenting concept cars designed through more ecological principles, in order to understand how the new technologies, demands and context will change the future automobile. The next sections analyse the trends these concepts are creating and their significance to the aesthetic of the Age of Sustainability.



**Functionalism** | Some of the trends of the Age of Sustainability represent the continuing evolution of others from the preceding age. The Fiat Ecobasic is strongly linked to the Fiat Multipla (figure 91), in proportion and style, and also to the Smart Fortwo, from which it brings the aesthetic and functional use of coloured plastic and modular construction. The car was designed to improve fuel consumption and lower emissions, focusing on a rational use of space and saving weight (Fuad-Luke, 2004). Despite some unusual detailing and its graphics, windows and lights, made to suggest a revolutionary design, the side profile of the Ecobasic still related it to its ICE architecture.



**Figure 91: Fiat Ecobasic Concept (2000).**

Functionalism is a strong rational principle in ecological design, one that is easily recognised, in terms of language and meaning, by the general public. Lidwell (2003) believes that 'the functional aspects of a design are less subjective than purely aesthetic aspects and, therefore functional criteria present clearer and more objective criteria for judgment of quality. The result is designs that are more timeless and enduring, but also frequently perceived by general audiences as simple and uninteresting.' Moreover, Functionalism will always relate to usability and construction and present a coherent language for technology and ergonomics. Thus, when alternative powertrains and energy sources are adopted in a functional design, the architecture and aesthetic of the vehicle will change.

Lakic's design for the Venturi Eclectic, analyzed in a case study here, is an example of this process. Instead of an internal combustion engine, the car is electrically-driven and uses three different energy sources to charge its batteries: on-board solar panels, attachable wind turbines and electricity from the grid. These choices are reflected in the overall aesthetics and architecture - with a technical skateboard housing the electric motor and batteries. The Eclectic has two parallel plans defining the volume of the car, structured by an exposed symmetrical space-frame. Once the car has no internal combustion engine, it can abandon the typical two or three-box configuration, and become a mono-volume with a significant amount of space in the interior and the look of a horse-drawn carriage.

The architecture also proposes a functional use of the interior, which is another significant focus of Functionalism. Many concepts are aiming to create more spacious and dynamic interiors, as a natural evolution from MPVs and SUVs. Turning the focus on the interior, some concepts have improved accessibility, like the Toyota Fine-T, that presented rotating seats and big doors, and some explored the styling, mixing functionalism with symbolism, like the Citroen C-Cactus' pictorial graphics of leaves (figure 92).



Figure 92: Citroen C-Cactus concept (2007).

**Biomorphic** | The symbolic use of natural elements and forms to create shapes that relate to the environment is a simple and direct metaphor, but one that alone does not guarantee a good outcome. There is the risk of producing a kitsch design language or an exaggerated and transient style. In 2005, Mercedes-Benz took a chance and presented the Bionic Kofferfisch concept (figure 93), a study of aerodynamics inspired by nature, and in 2007, the F700. Both concepts explored the marine theme, 'studying the morphology of a fish in the Bionic', and the 'elegance and agility' of a dolphin in the F700, according to the designer Peter Pfeiffer (Gandini, 2007).



Figure 93: Mercedes-Benz Bionic Concept (2005).

Mazda also tried experimenting with natural elements, but instead of animals, the designers were investigating the flow of air and water. With this in mind, Mazda

developed a five concepts, Nagaré, Ruyga, Hakaze, Kiyora and Taiki (figures 96-7). The latter was well received in the design community. Nick Hull (2007) wrote on the *Car Design News* website: 'The Taiki concept is deeply impressive on several counts: it's a well-resolved series of forms, based on a sophisticated underlying design philosophy that visually expresses air-flow. Mazda's design team has clearly found a rich vein of inspiration here that will be difficult for rivals to pick up without being accused of stealing Mazda's clothes.' Nevertheless, the foundations that made the shape of the Taiki so attractive could be traced down to the proportions of Classic Body and Flow Shell styles, and more clearly, some of the graphs, and flowing lines had been seen before in Peter Stevens' McLaren F1 (figure 94) supercar from the 1990s; and in parallel, the design director of Mazda, Laurens van den Acker, declared the intention of creating something as iconic and sculptural as the Bertone's B.A.T., from the 1950s (Hull, 2007).

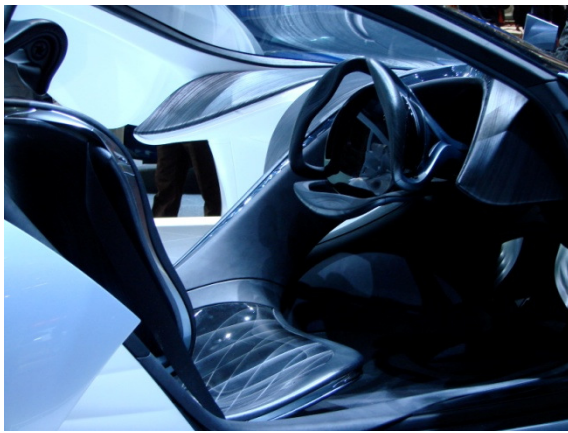


Figure 94: McLaren F1 (1994).



Figure 95: Mazda Taiki concept (2007).

To Mazda, the Biomorphic approach showed how elements of nature can shape bodies with harmonic smoothness. Marzia Gandini (2008) pointed out that 'the design of the Taiki was summarised in two concepts: lightness and sports spirit'. Thus, the flow of air, and as a result, the aerodynamics, were used as generators of the style. However, while the exterior body was logically-shaped, the interior showed a continuity of the language, as a mannerism, purely to repeat the Biomorphic style (figure 96). The dialectic, in this case, seemed to be solved by the beauty of the solution, whilst the consonance between interior and exterior might represent a uniform and informative solution: the interior and exterior have totally different functional requirements, and share the constraints of their materiality.



**Figure 96: Mazda Taiki concept (2007).**

The Taiki architecture was developed with reference to sportiness (Gandini, 2008) and the body shaped by air-flow, creating a sophisticated floor-plan, with side tunnels and diffusers (figure 97). Moreover, it also generates a visually-identified cockpit, that also connects the Taiki with another trend, the Cockpit Body.



**Figure 97: Mazda Taiki concept (2007).**

**Technomorphic** | The two different approaches to sustainable design, mentioned before in this research, bio-cycle and techno-cycle, have their respective aesthetics. They might appear as a consequence of a whole-design process, so the selection of materials and energy would inform the design; or it might only be represented through an intention of the character of the language; or both. Once the mix between techno-cycle and bio-cycle is most likely to be true in the Artificial Ecology, styling will more often define the trend..

The two different approaches to sustainable design, mentioned before in this research, bio-cycle and techno-cycle, have their respective aesthetics. They might appear as a consequence of a whole-design process, so the selection of materials and energy would inform the design; or it might only be represented through an intention of the character of the language; or both. Once the mix between techno-cycle and bio-cycle is most likely to be true in the Artificial Ecology, styling will more often define the trend. The difference between the language of the two trends lies in what the image of man-made and machine-made contributes - the Technomorphic - and what resembles the natural - the biomorphic. In design, this can be observed in the details of each language, and options for shapes, colours and materials. The subtle distinction can be observed in the 2009 BMW Vision concept (figure 98) in comparison with the Mazda Taiki. Both models were developed focusing on aerodynamics, but while the Japanese design was more concerned with the symbolism of the wind, as an element of nature, the German design paid attention to the development of aerodynamics in Formula 1 racing cars, and used Computational Fluid Dynamics analyses to guide the design (Cumberford, 2009e). In the final shapes, the Vision is expressed in straight lines, clearly defined angles and curves, while the Taiki is more organic.



**Figure 98: BMW Vision concept (2009).**

Nevertheless, Cumberford (2009e) observes that making an abstraction of the surface complexity and looking only at the centreline profile, the Vision was 'nicely proportioned



and elegantly sporty, and it favourably recalls a number of equally exciting past concept cars. The transparent sides were seen on Marcello Gandini's 1966 Bertone Concept - the Lamborghini Marzal - and recapitulated several times since'. Moreover, the movements of the surfaces can also be interpreted as Adrian van Hooydonk's evolution of the Carved Body designs by Chris Bangle for BMW. Together, the resemblances between BMW Vision and the Lamborghini Marzal, Mazda Taiki and McLaren F1 signal the way in which the past ages of car design might influence the design of the car in the Age of Sustainability. Sensibly, the iconography of the Technomorphic approach is traced back to the Wedge Line, and the Biomorphic to the Classic Body. In both, proportions, lines and shapes that were used as references were carefully reinterpreted. The evolution of the language follows the speed of that in powertrains, which have not been completely renewed.



**Figure 99: BMW Vision concept (2009).**

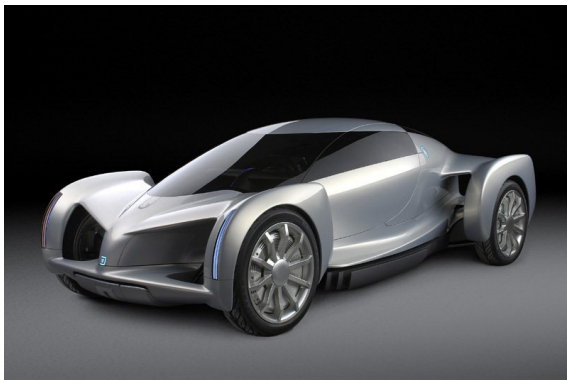


**Figure 100: Lamborghini Marzal concept (1967).**

The BMW Vision represented a change of direction for the BMW Efficient Dynamics programme. The 2009 concept explores the hybrid diesel-electric powertrain, instead of hydrogen. The hybrid adds more complexity to the architecture, and constraints to the whole design. Nevertheless, it is notable that the Vision, being a four-passenger car, is a hatchback, and therefore tending towards a trapezoidal profile, and not a traditional BMW sedan.

**Cockpit Body** | Different architecture, a consequence of alternative powertrains, and a teardrop shaped body that creates a visually-identifiable passenger space which defines the principal feature of the design, is becoming a trend in ecological concept cars.

In 2003, GM presented the Autonomy (figure 101), one of the most innovative concept cars of the decade, designed by Ed Welburn and Adrian Chernoff, in response to a request by the CEO Rick Wagoner to reinvent the automobile from scratch (Edsall, 2008). The GM Autonomy is a fuel cell-powered concept car, with steering, braking and other vehicle systems controlled electronically. The architecture is based on a skateboard, as mentioned before in this research. The result is an unconstrained body with free rein for designers to develop the interior and exterior. With the skateboard platform it is also possible to develop interchangeable parts which may help to extend car's lifecycle, create progressive updates and standardize manufacturing processes without loss of design quality. Nevertheless, most of the benefits of the skateboard architecture might be more appreciated in further development of the interior design. The Autonomy body presented freedom of form and the quest for better aerodynamics. Aesthetically, the concept referenced aeronautics, proposing that sustainability is compatible with high technology, as in a Technomorphic design. The strongest aspect of the design was, however, the volume, that separated cabin space and wheels, and created a Cockpit Body.

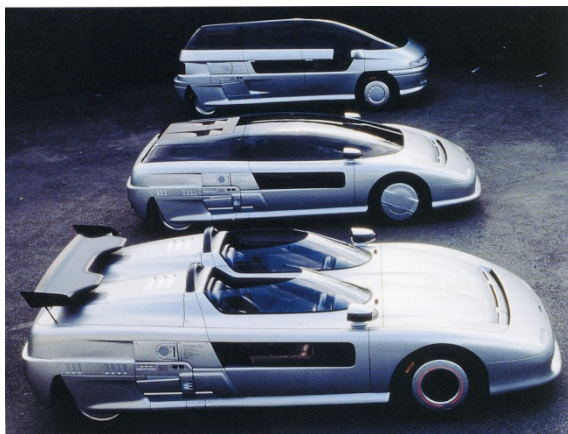


**Figure 101: GM Autonomy Concept (2003).**

The trend was also seen in the Venturi Astrolab concept (Figure 148), together with a language of Functionalism. The car, designed by Sacha Lakic, was unveiled in 2006. The idea was to create a new concept for motoring as a sustainable practice, using renewable energy resources: a sports car conceived around nature as a sailing boat. Thus, the Astrolab is a plug-in and solar hybrid, battery electric vehicle. The design started by aiming to give considerable space for solar panels, on the top layer. Under it, an aerodynamic body was shaped, and to reduce the frontal area, tandem seating position was adopted.

In the middle of the solar panels, a cockpit was created, in a Formula 1 vehicle style. The overall style, a mix of Functionalism and the Cockpit Body approach, expressed Ladic's distinct authorship, previously seen more prominently in motorcycle design.

The Cockpit Body approach was also present in proposals by other designers, combined with their personal style or beliefs. When experimenting with new technologies - hydrogen and hybrid - Giugiaro applied the ideas he had been developing from the 1960s. His Trilogy on a Fun Theme - the Aztec, Aspid and Asgard, from 1988 (figure 102), showed the principles which Giugiaro - and his son Fabrizio - would not abandon when proposing ecological concept cars. Thus, the combination of Wedge and Cockpit Body approaches, seen in the 2007 Vad.ho concept (figure 103), was a reinterpretation of his past ideas, aiming at new objectives.



**Figure 102: Giugiaro's Trilogy on a Fun Theme (1988).**



**Figure 103: Giugiaro Vad.ho concept (2007).**

The Giugiaro Vad.ho concept car presented an unusual layout, with two tandem seats placed alongside the BMW 12-cylinder hydrogen engine. The two fuel tanks were to be positioned at the centre of the vehicle. Fabrizio Giugiaro explained that the solution was a result of logical choices that have resulted in a renewed architecture, improving the



balance of the vehicle's handling. According to Fabrizio, 'the starting point for the project was a study in ergonomics: to create a two-seater sports car as large as a Ferrari Maranello, but having a frontal surface area with 20% less aerodynamic impact' (Baruffaldi, 2007b). The front was lowered and the two seats are protected by a fighter jet-like transparent bubble. The aesthetics of this proposal relate to aeronautics, a recurring feature in Giugiaro's work: this was also reflected in the interior design, and in the minimalist and high-tech trim. Giugiaro has used the Cockpit Body approach to allow, at the same time, a new architecture, good aerodynamics, and his traditional Wedge Line that was always symbolically connected to high technology, now seen as a path to sustainability. Although the iconography linked the Vad.ho to previous concept cars and racing cars, the overall aesthetic appeared to be very innovative while arriving with coherent architecture and freshness.

**Conservative** | Another concept designed by Giugiaro, the Toyota Alessandro Volta (figure 104), was an obvious attempt to keep the status quo of Italian carrozzieri without changes in the aesthetic. The Toyota 'combines the long-established Italian supercar design tradition with a cutting-edge, hybrid engine. The sense of form is not sacrificed to architectural eccentricity, in the attempt to accommodate the new propulsion technologies that designers are still unused to' (Gandini, 2004). The Volta was nothing more than another supercar, rooted in the Wedge Line style.



**Figure 104: Toyota Alessandro Volta concept (2004).**

This kind of design process generated a trend that is more a reflection of an attitude than a new style. The design language of the Conservative trend reflects many different past references and an effort to maintain styles of the past and conceal changes in technology. It shows that the speed of change in aesthetics is sometimes slower than the speed of change in technologies. The Conservative trend is commonly seen in some of the first

generation of production cars with electric powertrains. Significantly, the Tesla Roadster (figure 105), that aimed to be the first electric sports car of its time, was extremely conservative in styling, and borrowed its body from a ICE Lotus. The Fetish, the first car designed by Sacha Ladic for Venturi Automobiles, was supposed to be an ICE sports car; however, when the Monégasque company changed its plans and decided to produce the car with an electric powertrain, the design was unchanged. The Fetish kept its roadster character, but its design language was linked to Functionalism, and not as conservative as the Tesla.



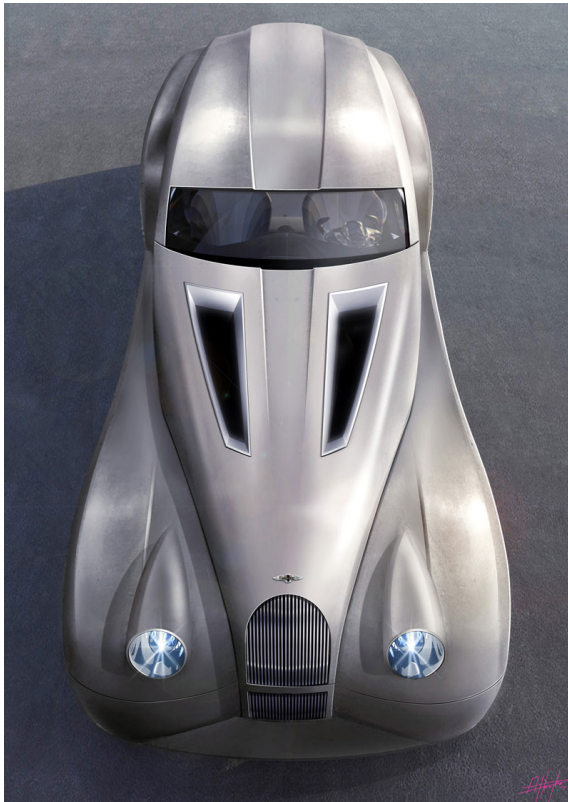
**Figure 105: Tesla Roadster (2008).**



**Figure 106: Chevrolet Volt (2010).**

The Chevrolet Volt (figure 106), planned to be marketed in 2010, also presented a Conservative style. The car has the traditional hatchback configuration and current Chevrolet design language. The conservative approach may reflect some fear of the companies about renewing their own design language, and losing their place in the market. The consumer who will choose an electric car will be challenging paradigms, but infrastructure and maintenance can present real obstacles to the first new generation of electric vehicles. A conservative customer would more often prefer a well-established petrol car.

The Conservative design can, at the same time, be coherent to a brand identity that follows closely its tradition. That is the case of the British independent manufacturer Morgan. The family owned company has been producing car for almost a century, establishing as a brand of excellence in craftsmanship. According to Nieuwenhuis and Wells (2009), Morgan's craftsmanship tradition is based on the use of renewable materials, notably, wood and leather, and the refinement and simplicity of the designs make the cars extremely light weight.



**Figure 107: Morgan LIFE Car concept (2009).**

Whilst the profile of Morgan Motor Company is adequate to sustainable development, enhancing the socio-cultural connection to local community, the scale of production doesn't allow fast replacements of models with different or fashionable design. Thus, the LIFE Car (figure 107) is strongly connected to the brand heritage of the Morgan 4/4 Sport. In addition, the company can develop its concept in close connection to researchers in advanced sustainable technology. Thus, the 2009 Morgan LIFE Car concept, explores at the same time, the sustainable and aesthetic potentials of recyclable lightweight materials, like aluminium and wood. The Conservative style of the exterior is an evolution of the current Aero 8 and Aeromax models.



**Figure 108: GM Jay Leno Eco-Jet concept (2006).**

Conservative design approaches are also linked to Edge Body and New Classic, as observed in the GM Jay Leno Eco-Jet concept (figure 108) and in the Fisker Karma (figure 109), respectively.

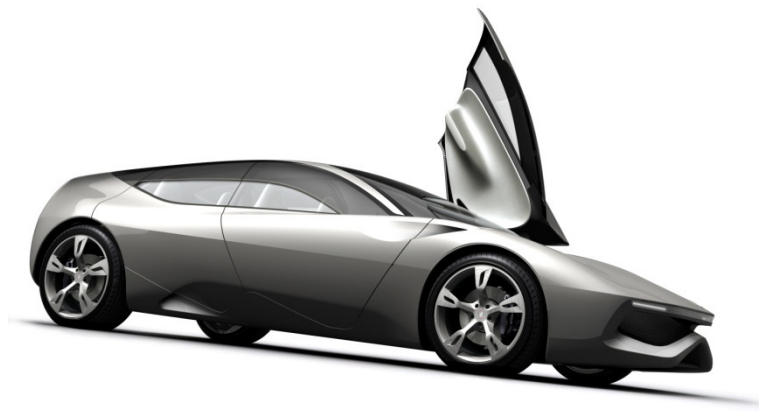
The Karma, is the first hybrid car from the independent company of Henrik Fisker - one of the designers responsible for Aston Martin's New Classic language. Like Murat Gunak, Fisker moved to his own company to have the opportunity of rethinking the automobile. Nevertheless, while Gunak - the Volkswagen ex-vice-president of design, responsible for cars like the Peugeot 206 and the Mercedes McLaren SLR - came up with the Mindset, an innovative, light, hybrid car, following the Functionalism trend (Weernink, 2009), Fisker held on to the Conservative approach and proposed a big, fast, luxury four-door coupé, with New Classic looks, in a company that has no past to refer to. The difference in styles is also a consequence of different target consumers. Therefore, what might look like a weak point of the design is sometimes the strength to create products to suit a niche market, with benefits to the environment.



**Figure 109: Fisker Karma (2009).**

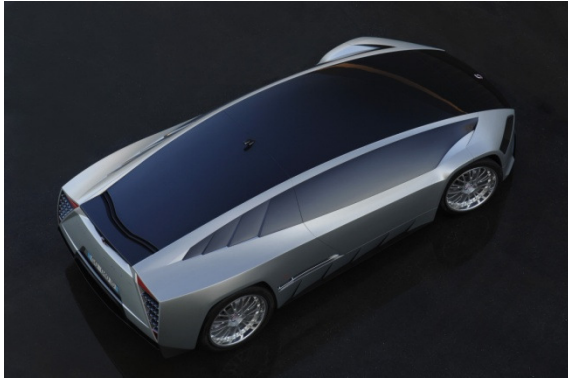
**Synthesist** | In Hegelian philosophy, synthesis is a new idea that resolves the conflict between the initial proposition thesis and its negation antithesis, an idea combining different things. In this research, Synthesist denotes the trend that combines new architecture, designed for more sustainable powertrains, and an established design language. This had been a particular specialism of the Italian carrozzieri, to keep their design principles while using new technologies.

The style was named after the Pininfarina Sintesi concept (figure 110), presented at the 2008 Geneva Motor Show. According to Baruffardi (2008a), the concept left the 'ordinary behind' and promoted the encounter between technology and aesthetics. 'It is a four seater grand tourer, with a low, elongated silhouette reminiscent of the Italian classics'. According to Pininfarina director, Lowie Vermeersch, the car was designed from the interior to the exterior body (Baruffardi, 2008a). The accessibility and mono-volume configuration follows the functional and aerodynamic requirements common to the Age of Sustainability. However, the interior layout is very traditional, due to the constraints of the fuel processor tunnel, which crosses the middle of the car.



**Figure 110: Pininfarina Sintesi concept (2008).**

The chief designer on the project, Giuseppe Randazzo, stated that Pininfarina is used to looking at the shapes of the past, not in order to repeat them but simply to absorb and reaffirm the spirit that has characterised the most successful expressions of its design (Pininfarina, 2008). The elegant lines of the Sintesi are the new interpretation of a sum of codices, a coherent balance of innovative sustainable design and references from the Evolutionary Age.



**Figure 111: Giugiaro Quaranta concept (2008).**

At the same time, at the Geneva Motor Show, Giugiaro unveiled the Quaranta (figure 111), to celebrate the fortieth anniversary of Italdesign. According to Bellu (2008), the concept aimed to crystallise the company's two strengths - style and technology - in a single object. The Quaranta draws inspiration from the 1968 Bizzarrini Manta, and continues some of the ideas introduced in the Conservative Toyota Alessandro Volta, including the hybrid powertrain. However, now the Wedge approach became a long arched roof, from front to rear, designed to carry a family, in a three and a half seat configuration. With this concept, Giugiaro proposed that a new typology of family car might be established as a new interpretation of his design principles. Moreover, his concept, with pure wedge forms, sharp edges, definite cut tail and high-tech look, is a clearly recognizable Giugiaro design for the Age of Sustainability.

**Clean Shape** | Mainly referencing aerodynamics and Minimalism, the trend of the Clean Shape appeared as an evolution of the Smooth Body, that was demonstrated in two important ecological cars of the 1990s, the hybrid Honda Insight and the electric GM EV1. The Clean Shape is characterized by soft edges, organic forms and a balanced mix of straight lines and curves.

Fioravanti, another Italian independent design studio, developed a number of concepts following this trend. The studio of the ex-director of Pininfarina showed two proposals of hydrogen-powered cars, the 2007 Thalia (figure 112) and the 2008 Hidra. The main difference between the two cars was the architecture, especially in relation to the position of the hydrogen tanks. In the Thalia, for safety reasons the tanks were positioned in the most protected part of the car, within the wheelbase and wheels. Thus, Fioravanti placed it under the rear seats and decided to turn this into an advantage for the rear passenger, raising their seat position by 30 centimetres. The roof was also raised and a second



windscreen was created, letting the rear passengers fully appreciate the front view. The front seats were lowered and thus the maximum height of the car stayed within the normal range for a compact model and in proportion to the length (Calliano, 2007). In the Hidra, the tanks were placed in a central tunnel – as in the Pininfarina Sintesi. The design language of the two models are the same: clean, dynamic, fluid and soft. According to Fioravanti, it was a good time to bring back two-tone bodies, and this made the Clean Shapes of the concepts look more interesting (Galvano, 2008a).



**Figure 112: Fioravanti Thalia concept (2007).**

The Clean Shape is also present in small cars, designed to save energy through weight saving and aerodynamics. The trend is, then, an evolution of Minimalism, with an emphasis on dynamism in the body, purism, and less symbolism. This approach tries to create an appealing design, apparently the case with the Pininfarina Bo (figure 113). Presented at the 2008 Paris Motor Show, Pininfarina planned to sell the electric car under its own brand name, showing again that independent design studios might step ahead and propose new solutions to mobility, even before the big car manufacturers. To achieve success with the Bo, the objective of Pininfarina is, according to Lowie Vermeersch, 'to satisfy the buyer who chooses a car that looks forward without relinquishing the prestigious traditions of the Italian coach-building art' (Baruffaldi, 2008b). Moreover, the Bo Clean Shape is neat and contemporary; its typology can be traced back to the typology of the Mercedes-Benz A-Class, and its ecological character is recognised, probably more so, by the use of visible solar panels.



**Figure 113: Pininfarina Bo concept (2009).**

**Communicative** | The coloured lights seen through the front solar panels of the Pininfarina Bo show an intention to communicate. In the interior (figure 114), the dashboard is dominated by active graphics, showing that the car's interfaces are becoming more intelligent and interactive, as expected of a car of a time when the information technology industry has overcome car industry.



**Figure 114: Pininfarina Bo concept (2009).**

Interactivity and connectivity are essential elements of an age of dematerialization. Images of the virtual and natural worlds are almost becoming equal in importance, especially to young people. Moreover, now that mobile phones and the internet have spread and speeded up communication, connectivity has become an addiction, and design has incorporated and stimulated this process.



**Figure 115: Renault Twizy Z.E. concept (2009).**

At the 2009 Frankfurt Motor Show, Renault launched three concepts for electric vehicles. The smallest was the Twizy (figure 115), a single seater quadricycle. According to Simpson (2009), 'the face of the concept is formed from a large hexagonal display matrix, which is



used not only for lighting and turn signals, but to communicate greetings and messages. The motif is repeated throughout the interior, with certain hexagonal forms providing the driver with vehicle information through the use of rear-projection.' In addition, the Renault presented very small footprint, but the typology might not give the same comfort and safety as a car, nor the same agility as a motorcycle. The new typology conflates car and product design, and might be accepted as an alternative, with a benefit to sustainable mobility.

Other concepts in the frontier between product and car design, and with a Communicative approach, is the Nissan Pivo (figure 116), first presented in 2005 and revised in 2007. The 2005 car presented a rotating cabin space that changed the style of driving, making reversing obsolete. The Pivo 2 has electric motors on each of the four wheels that can turn 90 degrees, allowing the car to drive sideways as well as forward. Moreover, the car takes interaction with the vehicle to the level of conversation, through a sympathetic 'robotic agent' housed in the dashboard (Car Design News, 2007a). The robotic look is extended to the exterior of the Pivo 2, which carries the symbolism of a head, that turns, stares and smiles.



**Figure 116: Nissan Pivo 2 concept (2007).**

Moreover, Communicative designs present at the same time the intention of interacting to improve connectivity and usability, and the notion of expressing a harmless and friendly character in a vehicle, implying respect to both user and environment. Thus, the Nissan Pivo 2 demonstrates an overall aesthetics, focused on principles of sustainability, that signals a move towards the paradigm shift.

### 2.3. Conclusion

According to Thomas Kuhn (1977), something that brings together members of a scientific community, and differentiates them from others, is having a specific language. The same occurs in design. As a language, design creates aesthetic experience, and is sometimes the cause and sometimes the consequence of its context. The first part of the literature review in this research studied the scenario of the search for sustainability and demonstrated the failures of current unsustainable paradigms. The acknowledgment of this weakness is, according to the same philosopher, a driver of change.

Although some question the established thinking about climate change, the scientific community generally accredits the findings of the related studies. Nevertheless, the search for sustainability is morally a wider imperative, and stands for itself. The social and environmental implications of current modes of production must be tackled, including the inequalities that are not conducive to sustainable practices. Unidirectional systems, in terms of energy and resources, need to be shifted. Therefore, designers must also take responsibility and act to develop sustainable solutions.

Designers act in response to the context and also to encourage future developments, to lead to new understandings of social metabolisms. At this point, it is necessary to discuss current societal values and move in the direction of new ones which refer to deeper concepts of quality. Sustainable design must communicate these new values. Thus, a revolution in design language, brought about as a response to a crisis, in this case the climate crisis, will lead to an aesthetic paradigm shift.

Kuhn (1962) says that 'successive transition from one paradigm to another via revolution is the usual developmental pattern of mature science'. Nevertheless, there is some resistance to renouncing the paradigms that led to the crisis. This tension is observed in the literature review, and is represented, on the one side, by industrial and social forces that attempt to preserve old paradigms, and on the other side by those who seek more sustainable ones. Because the quality of a future sustainable society will also depend on how the transition will be effected, transitional solutions have their value. Some of the developments towards ecological design are important when contributing to this process. Nevertheless, it is necessary to carry out a detailed analysis, to avoid mistakes.

Recycling and ELV policies are one example. Their existence will not guarantee the accomplishment of the recycling process if the lifecycle of the product is not controlled.

The system of acquisition is linear, and even a car, which is designed to be recycled, might never achieve this. Another solution that might create drawbacks is the adoption of biofuels. The great advantage for the industry and the economies of some countries is that, being renewable, the fuel will always be available and the prices may not increase at the same rate as oil derivatives, and that the technology is cheap and available.

Nevertheless, the growth of the agriculture relating to biofuels will interfere with the production of food, because land is a limited resource. Moreover, the assumption that biofuel stabilises the atmospheric CO<sub>2</sub> is misused, and its harmful side ignored or hidden.

Instead of focusing on biofuel engines, the industry should be working on the development of electric powertrains that are more energy-efficient and produce no pollutants during use, thus helping to improve conditions in local environments. In a scenario where cities have increasingly higher concentrations of population, low environmental impact vehicles also help to stimulate the use of other sustainable modes of transport, like cycling. Nevertheless, the sustainable car must be electric, and only use energy from clean and renewable sources.

In the context of electric powertrains, the hybrid car has been important to support the development of battery technology and to publicise the benefits of electrifying the powertrain. In contrast to this, the development of fuel cell technology has been too slow to battle environmental degradation, and offers only a distant possibility of a more sustainable solution. Moreover, producing and distributing hydrogen is difficult, and has a high environmental cost. As always, it is necessary to observe the whole lifecycle.

It is clear that to address the question of sustainability for the automobile an analysis has to be made from a wider point of view than just looking at the automobile as an object. The car industry and the oil and power sectors are powerful social forces, upon which most of the world economies are now dependent. They also sustain particular crises related to their paradigms of consumption and technology, and their ethical and ecological implications. As seen in the literature review, current unsustainable paradigms are not only being maintained, but are also being exported to developing countries, taking their environmental impact to an unprecedented level. Economic forecasts show an expansion of the current model of capitalism, which will impact enormously on the environment and society. The developing countries will be the largest contributor to the global vehicle fleet in the next decades. It is obvious that this should be done in a more sustainable way: these are the very places where public transport and high technology investment are less likely to happen. Thus, a sustainable private car is an urgent priority,

for these countries as well. To develop it, support from the major economies, rather than the exploitation and exportation of old, unsustainable technology, is essential.

The sustainable automobile is not available yet, but some effort has already been made in this direction: in this research some of these developments have been considered in the literature review, and some are studied closely in the case studies. Thus, the sustainable automobile is not a single design, but a process towards reaching sustainability. Walker (2006) adds that sustainability 'not only implies diversity, it demands it, because sustainable approaches are so strongly associated with the specifics of place, region, climate and culture'. It follows that a paradigm shift in car design can help to give society a more sustainable future, with more respect for people and their cultures. Expecting homogeneity and simplicity is to underestimate designers' competence. The assumption that a sustainable world is a world of privation does not suit human beings' ability to endure hard times. Moreover, sustainability represents much more than simply an analytical approach to environmental auditing, it also represents a way of acknowledging our values and beliefs, in ascribing meaning to our activities. Thus, the language of sustainable design becomes a decisive factor in a successful transition.

In taking a path towards sustainability, the aesthetics of the automobile shifts. Some changes are easily identifiable, but also present challenges. A sustainable automobile must be designed with good aerodynamic performance, possibly leading to indistinguishable shapes: this would be unacceptable to the car industry. Thus, it is unlikely that aerodynamic perfection will be ever achieved. Also, as a result of following certain aesthetic and production paradigms, many designs might not benefit completely from the architecture of the new vehicle.

To understand better the paradigms of aesthetics, the second part of the literature review observes our affair with the automobile, now haunted by increasing ethical concerns. This causes the current paradigm to fail, because it is difficult to feel delighted by the automobile while knowing it causes enormous environmental devastation, and contributes to a system that is permeated by unconscionable social inequities. By contrast, as Walker (2006) observes, 'sustainable approaches to design have the potential of not only ameliorating the environmental and ethical concerns associated with conventional practices, but also of helping to create material culture that truly is a thing of beauty, which can find delight because it is a meaningful expression of human values that are responsible, ethical and caring'. Thus, reframing aesthetics is a decisive milestone in the process of creating the sustainable car. Walker (2006) adds that 'it is critically important

how things look – because ‘how things look’ is a reflection of ourselves, of who we are, of the things we believe are important and the things we choose to ignore’. The sustainable automobile should offer an alternative route to design development, which will lead to solutions that will change the way we drive, look, feel and understand cars. From this point onwards, car design must focus on the mythical goal of sustainability, and will have to be grounded in ideas of environmental and social responsibility.

The car industry has demonstrated progress in the search for more sustainable cars, but most of the time it does not have enough freedom to focus on ‘paradigm shift’ concepts. Some designs have failed to inform their ecological benefits. On the other hand, the designs emanating from independent car design studios present, rather, a significant evolution of aesthetics and technology. Regardless of whether these have actually been built or not, these concept cars may help to reframe aesthetic standards. In the last section of the literature review, some of the new trends have been included, and their significance for a future automobile aesthetic analysed. Not all the trends contribute to creating a new design language, however: some proposals are successful while informing new ideas of product design that might be incorporated into a contemporary aesthetic typology for the automobile. Consequently, the more technologically innovative the design, the more its aesthetic properties change. Thus, a whole-design process is more likely to create a aesthetic paradigm shift.

The historical study of car design trends has helped to create an understanding of the evolution of the aesthetics and how this will influence the Age of Sustainability. The study of the Age of Pioneers showed how a particular design language emerges, and how the symbols progressively populate our imagination. Particularly important to this study was the recognition of the three myths that sustain our love affair with the automobile: Freedom, Comfort and Speed. These myths characterise the status one acquires in association with the automobile, and represents the fulfilment of one’s wishes, more symbolically than practically. These myths were then observed in the Evolutionary Age, that also reflected the broadening of car design in many different directions, creating both more and less creative designs, and some great automobiles. The study of the Evolutionary Age showed the importance of particular tastes and culture and how they influenced aesthetics and created the identity for the brands. Moreover, the icons of the Evolutionary Age changed our lifestyle and aspirations and the car became a mythical object that means much more than a simple tool. As suggested, powerful references also imprisoned car design in its cage of introversion, a common aesthetic paradox. This stress point revealed a weakness in the current paradigms, and created the common assumption that

the age of car design is coming to an end. In addition, the changes in context, the search for a more sustainable future, and also independence from oil and its associated crises and practices, expanded the paradigm failure to a wider context.

The bankruptcy of GM was recognised as the end of the Evolutionary Age. The beginning of the new one was characterised by the search for a new identity for the automobile. The renewal of aesthetic paradigms has proved to be very difficult, not only because it has to deal with infrastructural changes, but also because, having become a popular product, car design has to consider different levels of aesthetic understanding and taste. Changes in the design processes might lead to more sustainable solutions and create a new aesthetic paradigm, especially if it reaches a deeper level of intervention. New design proposals must observe that what users demand are the results that a system of products and services are able to achieve. Thus, it is important to understand the meaning and benefits that the automobile gives, and from there, create new and sustainable paradigms, encompassing technology and aesthetics.

What is observed is that the speed of a revolution in technology appears to be faster than that of an aesthetic one. This might be a consequence of the current design process, which has often, as observed in the Evolutionary Age, been locked into a 'cage of introversion'. A concept for a fuel cell car, developed by trainees at Mercedes-Benz, referring closely to the Benz Patent model (Fig.117), represents a moment when new inventions in technology do not yet come with a design identity. Nevertheless, seen together, both the study of sustainability and more sustainable technologies, in the first part of the literature review, and the study of aesthetics, in the second part, show a confluence that has created an appropriate moment for a Paradigm Shift. According to Kuhn (1962), in science, only revolution can lead to a new understanding, thus a Paradigm Shift is necessary to reframe the aesthetics of the automobile in the Age of Sustainability.



**Figure 117: Benz Patent and Mercedes-Benz Fuel Cell Roadster.**

### 3. Methodology

According to Bruce Archer (1996) research is a systematic enquiry whose goal is to communicate knowledge. The activities of searching, enquiring, investigating, exploring, discovering, as much as art and design practices, may constitute research if they are systematically conducted, have explicit data and appropriately validated outcomes. Thus, it is important to explain in detail the methodology adopted in this research, also because, as Archer (1984) notes, 'the traditional art of design - that is, selecting the right material and shaping it to meet the needs of function and aesthetic within the limitations of the available means of production - has become immeasurably more complicated in recent years'.

In addition, once this research was developed in parallel with practice-based creative work, with the aim of experimenting with a future aesthetic, to meet the objectives of this project, it was necessary to develop a specific design model - shown in figure 118 and explained in the next section. Thus, this research methodology is a combination of research and design processes, and the Research Method Map was created as a design model.

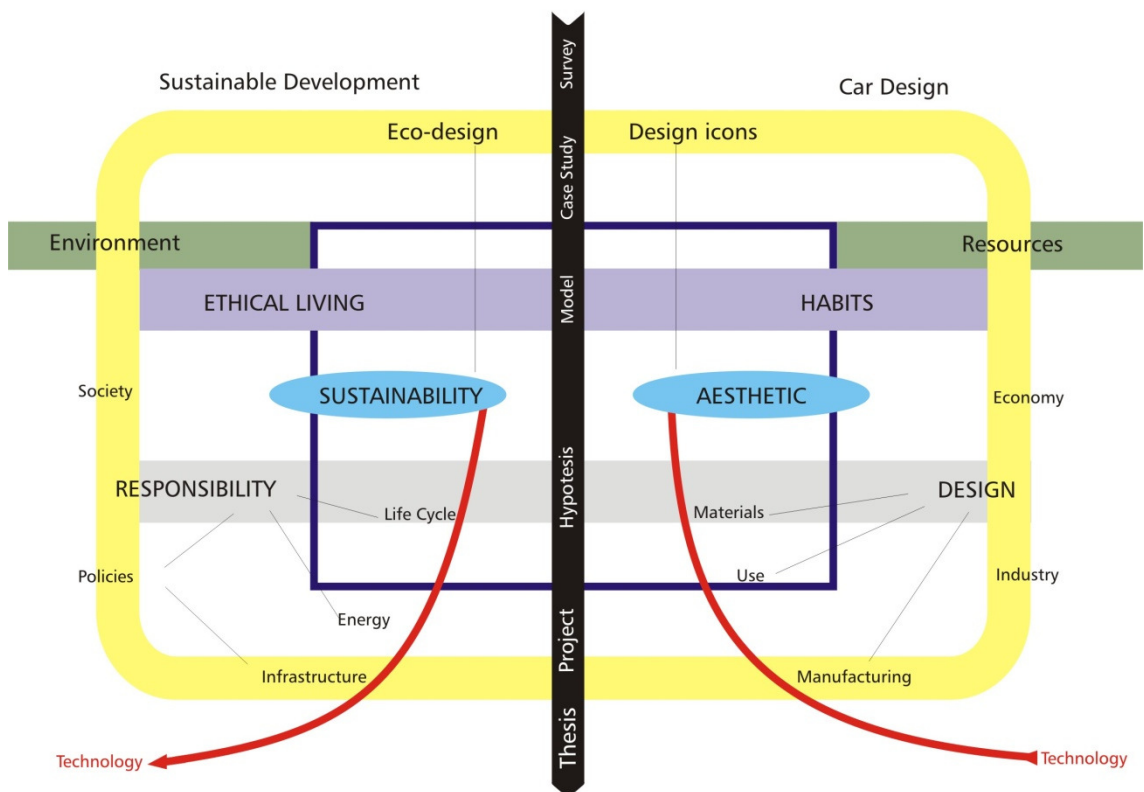


Figure 118: Paradigm Shift Research Method Map

### 3.1. Design model

While planning the trajectory of this research, I acknowledged Archer's three-phase model - analytical phase, creative phase and executive phase - as the basis of starting the investigation (Cross, 1989).

Recognizing that the analytical phase of the design was represented by the literature reviews and case studies of the research, I started mapping the terrain to structure the contextual review by focusing on critical thinking. Thus, following Carole Gray's (2006) principles of visualizing research, from the key words of the research I developed a mind map.

With the addition of the two circuits of interaction (the blue square representing the user circuit, and the yellow representing the contextual interaction), the mind map became an interpretation of the man-tool-work-environment system proposed by Archer (1984). Thus, it was possible to visualize the whole system into which the proposed research was inserted.

Symbolically, the design process was in a line between the two sides of the map - aesthetics and sustainability - so there it was located. Thus, the analytical phase stretched from the survey of car design and sustainable development to the case studies related to the design icons. Following that, a new model of society, with ethical habits of consumption and behaviour, raised the hypothesis of the research. Then the creative phase started, with the development of conceptual designs, and finished with the embodied design, and the thesis.

Whilst the design model presented similarities with Pahl and Beitz's model of the design process (Cross, 1989), it did not attempt to cover the whole design process, but to align with the objectives and resources of the research. Thus, the executive phase was not included in the project.

The design models referenced in this section are presented in figure 119.

The methods used in each stage of the research are explained in the next section.



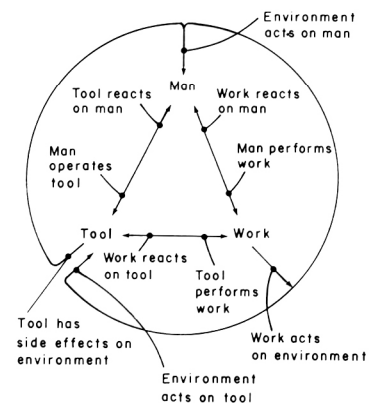
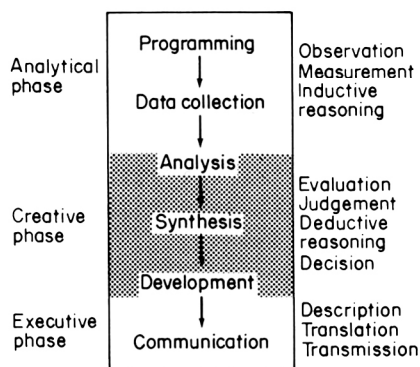
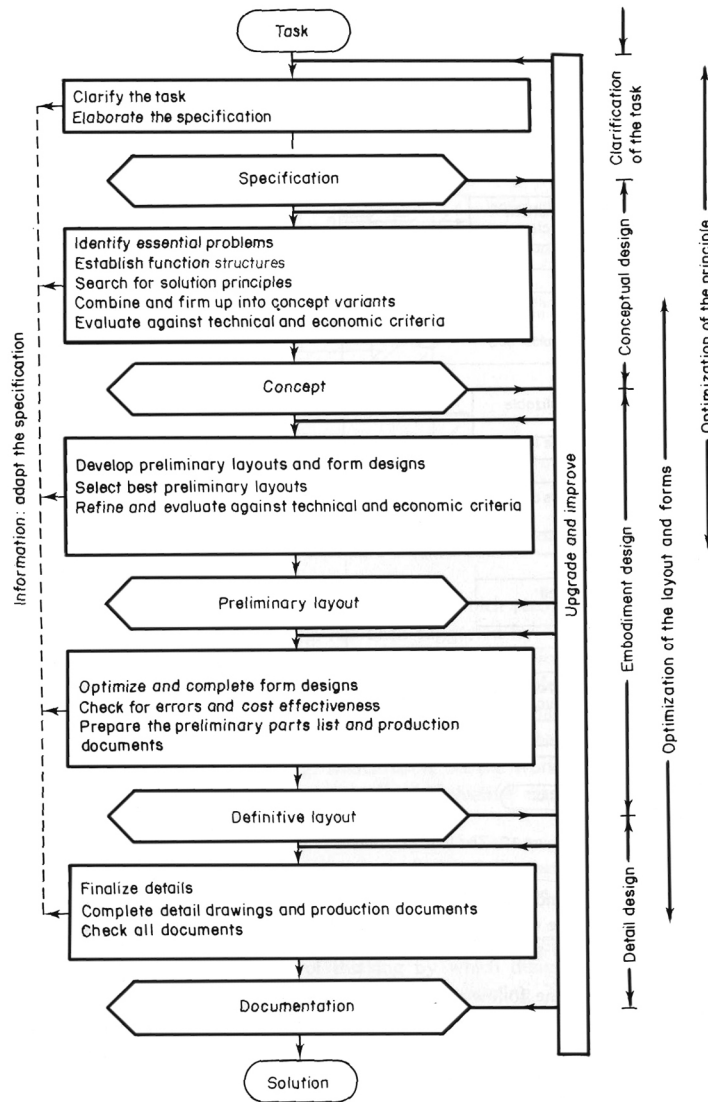


Figure 119: Design models used as references: (top) Design Process by Pahl and Beitz, (bellow) Three Phase Model and Men-Tool-Work-Environment System by Archer.

## **3.2. Research stages**

According to Gray and Malins (2004), 'methods are specific techniques and tools for exploring, gathering and analysing information, for example, observation, drawing, concept mapping, photography, video, audio, case study, visual diary, models, interviews, surveys, and so on'. While combining some of these techniques in a design process, the methodology of this research emerged through exploration.

Also according to Gray and Malins (2004), the key characteristics of research methodologies in art and design, with a practice-based approach, include the 'making of art/design/creative work through specific project frameworks or as a body of work exploring the research questions, which might include, or be supplemented by', among others:

- visualisation, drawing
- concept mapping, mind mapping
- brainstorming
- sketchbook
- 3D models
- experimentation with material and process
- collaboration, participation, workshops
- story boards, vision narratives
- decision-making flow charts
- exposition and peer feedback

Some of these methods were used in different stages of this research, as described in the following sections.

### **3.2.1. Literature review**

From the early stages of this research, the literature review was structured to cover two broad areas of study: aesthetics and sustainability. The focus of the writing maintained a close association with the automobile itself. The necessity of exploring all the subjects as deeply and broadly as possible has required an extended review, ranging from key reference books about sustainable design to articles about automobile history and design in car magazines. In addition, the subject being a very contemporary investigation, the study of academic papers and attendance at conferences relating to ecological car design

has been necessary to ensure that the research is up to date. Visiting and collecting information directly from motor shows has also been important, reflecting the point from which ecological car concepts have become the majority.

The literature review was also important to provide a broad understanding of car design and identify and address gaps in the current literature. Significantly, the study of car design shows the necessity of outlining its history in pre-war times. The current trends, represented by the ecological concept cars, which are very important to the understanding of future automobile aesthetics, were analysed in a few publications and several specialist magazines, but lacked classification and identification. Thus, based on the basic structure proposed by Paolo Tumminelli, the literature review augmented the existing study of car design history.

The section entitled 'Automobile and Aesthetics' showed the importance of diversity in design, which led to the decision to propose a project that would allow diverse outcomes. The survey was important to understand the particularities of car aesthetics through the ages, and then, direct the design to a paradigm shift.

To understand the Age of Sustainability, the section entitled 'The Automobile and Sustainability' covered subject matter related to environmental impacts, infrastructure, technologies, the Climate Crisis and sustainable design. In this area it was especially important to bring together the conceptual studies of Manzini and Papanek, Walker's studies in aesthetics, and Ewing and Andrews' specific vehicle studies.

The literature review in this research thus helped to structure the background of the research and to formulate the briefing for the project, aiming to create a better response to the research questions. The most important conclusion of the literature review was that there is both the necessity and the opportunity to effect a paradigm shift in car design.

### **3.2.2. Case studies**

The case studies emerged from the literature review investigation. While studying the symbolic aspects of car design, three myths that support people's love affair with the automobile were identified: these are Freedom, Comfort and Speed. These myths were again observed in the case studies. The Myth of Freedom is investigated together with the study of a contemporary epitome of freedom which also aims for sustainability: the Smart Fortwo. Following the same principle, Comfort was studied in relation to the Toyota Prius, and Speed by looking at the Venturi.

The case studies also aimed to look at some key players in the industry, to understand in depth their strategies concerning the environment. In addition, the case studies presented more profound analyses of the selected cars, from the observation of the design for test driving, all in order to bring a broader aesthetic judgment.

The methods adopted in the case studies included: literature survey, interviews, design analyses through images, collection of data and experimentation through driving.

### 3.2.3. Project

As a design practice work, the research made consistent use of visual support material, from the literature review to the project. The review of the issues relating to aesthetics was developed using the Car Design Timeline presented as a frontispiece. The relevance of the three myths and the organization of the history into three ages evolved through the construction of the Timeline.

The three myths were then applied to another visual resource, the Project Chart, shown in the respective chapter. The meanings of the myths, and their sustainable reinterpretation, were later discussed and defined in a brainstorming with research colleagues, using the Project Chart. The Project Chart helped to map the differences between new and old paradigms, necessary for, according to Walker (2006) and Kuhn (1962) reframe the aesthetics.

These three myths formed the pathway to a learning-through-doing process, whose final results are the outcomes presented in Chapter 5. Using Carole Gray (2006) as reference, the method involved:

- Reflective observation carried out in the literature review and case studies.
- Abstract conceptualization: when the initial inspirational designs were created and used to help define the project briefing. At this stage, sketching and modelling were used in an *art as research* process, to consolidate the hypothesis to be investigated in the next stage. According to Archer (1996), 'there are circumstances where the best or only way to shed a light on a proposition, a principle, a material, a process or a function is to attempt to construct something or to enact something calculated to explore, modify, embody or test it'. In this project, the principle was to bring the abstract conceptualization as close to art as possible, once the review showed that the proximity between car design and art have well-established potential to bring about aesthetics which are both surprising

and admired. Moreover, the acknowledgment of sustainability as a kind of utopia, proposed by Walker (2006), suited an artistic approach to the project investigation. The design strategy also observed Manzini and Vezzoli's design guidelines for sustainability (1998), that in addition to the other design methods presented in the literature review, showed that to reach more efficient sustainable designs it is more important to: first, design the strategies of the product; second, the conceptual design; third the embodiment design; and fourth, the detail design. Thus, the project focused on reframing the aesthetic based on the meanings, which combined concrete needs with abstract aspirations.

- Active experimentation, when the briefing was given to a group of designers from the Royal College of Art Vehicle Design MA course to produce a series of design concepts. The project was systematically conducted, following my guidance and using the Project Chart and the specific briefings as references (all presented on Chapter 5). In order to follow up the development of the concepts, an interim presentation and debate took place a week after the project launch (figure 119). The active research was intended, as Archer (1996) suggests, to produce new knowledge, and also to test the research hypothesis.

The outcomes were discussed in a debate participated in by students, tutors and researchers of the department, the research supervisor and a key designer from the industry, with the aim of having an impartial and broad evaluation, as suggested by Archer (1996). The evaluation methods are transparent and shown in the respective section of Chapter 5. Those included: (i) interview with a design tutor; (ii) transcription of the opinions of the designer from industry that are recorded in video; (iii) analyses of the aesthetics of the designs, following the method of the literature survey; (iv) empirical evaluation of the ecological credentials of the designs, according to Vezzoli and Manzini (1998).

Finally, a selection from the project's final outcomes joined the Car Design Timeline. Together with the other concepts of the Age of Sustainability, they showed a series of new trends that were classified and analysed in the Conclusion. This group represents the aesthetics of the automobile in the Age of Sustainability. These revolutionary designs, that firstly led to a new understanding of auto-mobility, secondly reframed the aesthetics, changing the image of the car from that of an enemy of the environment, and thirdly proposed a renewed interpretation of the three myths, are the Paradigm Shift automobiles.

## 4. Case Studies

**Introduction** | In this chapter, three case studies are presented in order to create a deeper understanding of the automobile industry's strategies towards sustainability. The focus was on current car models designed according to ecological principles that have stood out as successful designs, either in the market or as design references. The selection of the cars was made with the aim of including different typologies (city car, sports car and family car), different powertrains (ICE, electric and hybrid), and the three myths investigated throughout this research (Freedom, Speed and Comfort).

The first study is of the Smart Fortwo, one of the most sustainable cars on the market, which, however, follows the German *Kleinwagen* tradition rather than appearing to be a fashionable turn-of-the-century 'green car'.

The second study was carried out on a sports car brand that changed its focus to building ecologically-sound vehicles: Venturi Automobiles. Thus, the Venturi case study observed not only the Venturi Fétish electric sports car, but widened its analysis to the brand's other models, in order to understand how an independent car company can fill gaps in the market and propose new typologies of vehicle to renew automotive paradigms. The study also followed the work of a particular designer, Sacha Lakic, responsible for all Venturi's new models, interviewed for this research in 2007 and later at the 2008 Paris Motor Show.

As the most successful hybrid car in the market, the Toyota Prius was selected for the third study. The Prius has had an impact largely on the imagination of environmentalists or eco-friendly people, and its aesthetic is considered partially responsible for this.

All the companies analysed in the studies are currently marketing their vehicles in Europe. The intention of the study was not to observe the global market, but to go deeper into analyses of cars designed for a large but still limited market. The Prius is sold in Japan, USA and Europe, however, while in Brazil, Toyota is betting on biofuels. The Smart Fortwo started to be exported to North and South America during the period of this research. Venturi Automobiles has even more limited market aspirations. Nevertheless, seen together, the cars studied in this chapter are creating a new and more ecological understanding of the automobile, and becoming aesthetic reference points, both to users and designers.

## 4.1. Smart



Figure 120: Smart logo.

### 4.1.1. Introduction



*“The car became ubiquitous because it fulfils various practical and psychological roles and because it simultaneously contributed to and was influenced by societal, cultural and environmental change” (Andrews, Simpson, Nieuwanhuis, Ewing, 2002).*

Figure 121: Smart Fortwo (2007).

The cities of the 20th century were mostly redesigned to suit a car-orientated society, as discussed in the introductory chapter of this research. Urban areas also had to absorb much of the world's population growth within their boundaries when more people started moving from the countryside to live in the city. The number of cities with more than one million inhabitants grew from 86 in 1950, to 100 in 1975, and 257 in 2000. The number of megacities (those with more than 10 million inhabitants) is expected to increase from 2 in 1975 to 26 in 2025 (Wilheim, 2008). Most of these will be in the developing world, where the infrastructure struggles to catch up with this speed of growth. Thus, while public transport fails to provide adequate solutions to mobility, the automobile continues to be an immediate alternative for the individual who expects to move around with freedom, speed and comfort.

Some of the consequences of these transport developments have led to a deterioration in the quality of life in the city, and the progressive degradation of the urban environment. Huge traffic jams and lack of parking space are problems which are exacerbated by the use of the car, especially when four-passenger cars are used most of the time by only the driver. According to Fuad-Luke (2004), single-occupancy cars account for almost 80% of urban journeys. From the point of view of sustainability, it follows that the smaller the car, the smaller the ecological footprint. Microcars, hypothetically, consume less energy and raw materials in production and use. It is unquestionable, however, that microcars normally occupy half the land area of a regular car. And, as space will become increasingly valuable, according to principles of sustainability it has to be shared more equitably. Independently of the powertrain, size will always matter. These facts alone would justify the urgent development of smaller cars. Historically, however, the relative success of one- and two-seaters has never reflected this priority.

After the Second World War, the rationed economy stimulated the development of small vehicles. Their designs were not simply aiming at an easier adaptation to city centres, but were also searching for low operation and manufacturing costs. New trends appeared, such as the 'Bubble' and 'Mini' cars, studied in the Evolutionary Age section of this research. The German microcars, the *kleinwagen*, were affordable options to a market in recovery, and a business opportunity for former military companies, who were forced to change to other activities. This was the case for Messerschmitt, a former aircraft manufacturer that started producing 'Bubble' cars. BMW also produced a Bubble car, the Isetta, designed in Italy, where Fiat, with the 500, and Piaggio, with the Vespa scooter, put the country back on the move. With economies getting better, most of the microcars disappeared. The Fiat 500 and the British Mini survived, but there was a lack of new design in this category.

After a long period of absence, microcars have been seen again as good option for urban commuting. The Smart Fortwo (figure 121), also known as Smart Car, is largely responsible for creating a positive image for this category of cars. The Smart is one of the most important ecological cars recently produced and its study is necessary for the understanding of the evolving aesthetic of sustainability. This case study focuses on the Smart Fortwo model, and includes analyses of its design and market, looks at the history of the company and its approach to sustainability, and adds the formative impressions of five days' experience with the car.



#### 4.1.2. History of the company

Smart is a German company, originally called Micro Compact Car Company (MCC), and formed by the association of Daimler-Benz and the most prominent Swiss watch manufacturer, the Swatch Group. This combination brought together companies from two different design backgrounds, product and vehicle: on the vehicle side, one of the most traditional companies of all time, and on the product side, a watch company founded with the objective of producing a popular watch and re-capturing the share of the market lost to Japanese manufacturers.

Therefore, for the development of its basic range, Swatch redesigned the quartz watch for manufacturing efficiency and fewer parts. Compared with conventional watches, this model was 80% cheaper to produce, and used just under half the number of components. Together with this technological achievement, the company introduced the 'Swatch style', according to Bayley (2008) an 'un-Swiss' character - funky, sexy and humorous. The two main features of this were the use of plastics, allowing a strong combination of colours (see figure 122), and the structural casing, with the battery on the outside. After selling 150 million watches, the chairman of Swatch, Nicolas Hayek, decided to apply their industrial formula to automobiles. (Sancton and Studer, 1994).



Figure 122: Swatch watches.

The company started to develop a concept car 'to transport two people and a case of beer': the Swatchmobile. The idea was taken to Daimler-Benz, and a joint venture was established in the early 1990s but for a while, the companies worked on separate concepts. Early prototypes were developed partly in Germany and partly in the USA. The first concepts developed were the 1993 Eco Sprinter (figure 123) and the 1996 Smart, unveiled in Atlanta, USA (Smart, 2010). In 1998, after suffering heavy losses, Swatch left

the joint venture, but traces of the 'Swatch style' remained in the coloured plastic panels, joyful lines, and modular construction.



**Figure 123: Eco Sprinter Concept (1993).**



**Figure 124: Smart Atlanta Show Car (1996).**



**Figure 125: Smart City-Coupé Fashion Victim Concept (1997).**

In 1997 the German chancellor Helmut Kohl and the French president Jacques Chirac opened the Smartville plant, in Hambach, France. The production facility immediately won

environmental awards. Smart demonstrated not only respect for the environment but also to individual taste, launching the City-Coupé Fashion Victim (figure 125) at the Frankfurt Motor Show.

The Smart City-Coupé, later renamed the Fortwo, went into production in 1998. Nevertheless, the company was in difficulties. At the 1999 Frankfurt Motor Show, the Roadster concept was launched. The car was a contemporary interpretation of the English roadster, and 35% of its parts were the same as those in the Fortwo. The two-seater (figure 126) started production in 2003, while the company suffered from criticism over the Smart Car's poor stability. Later in 2004, the four-seater compact car, Forfour (figure 127), was launched. However, both of these were discontinued two years after release, and only the original Smart Fortwo survived.



**Figure 126: Smart Roadster (2003).**



**Figure 127: Smart Forfour (2004).**

In March 2001 Smart presented the Crossblade concept (figure 128) , as a preview of future roadster configuration, focused on driving fun. The Crossblade had no doors or roof, and all the interior elements were waterproof; there were even channels in the floor to allow rainwater to drain away. The Crossblade was produced in limited numbers from

2002 onwards, and was the only entirely open vehicle that could be driven at more than 25 Km/h without a helmet. The car provided an intense experience of speed, relatively slowly. The first Crossblade was bought by the British music celebrity Robbie Williams, and accompanied him on his European tour (Smart, 2010), showing that Smart was both green and cool at the same time.



**Figure 128: Smart Crossblade (2002).**



**Figure 129: Smart Crosstown Concept (2005).**

At the 2005 Frankfurt Auto Show, Smart unveiled the Crosstown concept (figure 129). The Jeep-like appearance of this model abandoned the mono-volume and adopted the two-box retro style. This reference was made at a time when Chrysler and Daimler were associated. Moreover, the concept used a hybrid powertrain, that would lower even further its CO<sub>2</sub> emissions, and was a four-wheel drive. Once again, Smart proposed that sustainability could be fun too.

Even in the newest models, the roots of the Swatch aesthetic were always maintained, and the brand evolved with a strong identity. In 2008, with 139, 964 cars, Smart accounted for approximately 10% of the Daimler Group's global car production (OICA,

2008). Well-established in Europe, the company debuted that year in the North American market, traditionally dominated by pickup trucks, SUVs and big sedans. This will be another big challenge for the small car.

### **4.1.3. Smart and sustainability**

As part of the Daimler group, Smart follows its environmental guidelines. "Protecting the environment, energy efficiency and preserving natural resources are all key considerations" (Smart, 2007). However, in a diverse group like Daimler the meaning of sustainability may be very different to that which informs the practices of companies like Mercedes-Benz and Smart. The main difference is the manufacturing concept for the Smart. This was created alongside the car, and is independent from traditional car manufacturing paradigms. According to Andrews, Simpson, Nieuwanhuis and Ewing (2002) "the development of more sustainable automobiles will only occur through the development of new automotive design and manufacturing paradigms".

In order to achieve a good ecological performance, Smart's idea was to go back to the beginning and design cars around user needs rather than the production process. The 'rttm' (reduce to the max) philosophy, which adds up to minimum frills for maximum content, was one starting point for the design.

The Smart design also facilitates recycling. The car is built from pre-assembled modules that make it easier to dismantle it. The number of components was reduced, to facilitate the recycling process. This was also the reason for the selection of synthetic recyclable materials. For example, the wheel housing covers are made from 100% recycled synthetics and the dashboard is made of polypropylene. According to the company (Smart, 2010), harmful substances such as lead, chromium, mercury and cadmium are eliminated from the production process, and PVC is almost completely avoided. The Tridion safety cell, which is the basis of the architecture of the Smart, is made of steel and finished with powder-coating that uses 40% less energy than conventional methods of painting, and does not consume water. Besides saving energy through a simplified manufacturing process, the Smart plant was designed to use the excess heat from injection-moulding machinery to heat the painting cabin air supply, for example. (Smart, 2007).

Environmental management has always been a priority for Smart. On the company website the company takes on the 'responsibility for fulfilling the ecological demands of today and tomorrow', and places its products 'as milestones for environmentally-

compatible individual mobility' (Smart, 2010). Smart has been compliant with ISO 14001 since 1997, and controls its suppliers by following the same standards. The environmental impact is controlled by a Life Cycle Assessment, provided by GaBi Software. This evaluates the demands for raw materials and anticipates future emissions and waste.

In the Fortwo, plastics were used on the exterior body, which can lower the high environmental costs of the painting process. The modular plastic panels also allow personal customization, facilitate repairs and contribute to extending the lifespan of the vehicle, through changes of fashion and technology. Moreover, the design concept of the Smart was based on satisfying the need for individual mobility with a smaller ecological footprint. *Less is more* could easily be the Smart's slogan. Although microcars are not a novelty, the way the Smart suits today's environmental requirements is totally up-to-date. In 1997, *Auto & Design* magazine presented it as "the first car of the 21<sup>st</sup> century. The car represents a real attempt to rethink the relationship of the car to the urban area. A car that, much more than a means of transportation, is a declaration of love to the city". (Cornil, 1997)

#### 4.1.4. The Fortwo



Figure 130: MCC Smart City-Coupe (1997).

**Design story |** According to Kacher (2008), when conceiving the Smart Nicolas Hayek's vision 'was a cheap, small, and environmentally-friendly commuter car that would also be available as a zero-emission vehicle, fitted with electric wheel-hub motors'. But Hayek pulled Swatch out of the joint venture in 1998, and the designer Johann Tomforde developed the rear-engine petrol City-Coupé (figure 130).

The Smart City-Coupé was developed in Smart's own design studio but under the wing of Daimler-Benz. This could explain its resemblance to the Mercedes A-class. Both cars are



mono-volumes, ensuring the best internal space in small dimensions. The style of the Smart seems to be an evolution of the A-Class, considered by Paolo Tumminelli to be an example of New Edge Box style. "In principle, this is a fusion of Edge, Flow and Graph elements: rounded forms flow into sharp edges and pointed angles and this is how they become more interesting". The lines and forms flow sharply and more geometrically in the Smart.

The most noticeable aspect of Smart's aesthetic appeal is, the way the Tridion cell is displayed. The Tridion cell is, the basis of the car's architecture, around which the car is arranged in the traditional Swatch way. This highly distinctive unmasked cage, presented in a different colour from the plastic body panels, ended up being the Smart brand's DNA. The later models, the 2003 Roadster and the 2004 Forfour, repeated this styling solution, enhancing the value of the architecture.

The car's colour composition, originating in the definition of materials, treated with an environmentally-friendly painting process, is also a Smart trademark. Significantly, several concept cars from other brands that were released after the Smart also combined functional parts with colours and materials, showing the influential power of the Smart design language, which was emphatically associated with sustainability.

The four wheels are set at the four corners of the body, showing off a little, and giving it a stronger presence, desirable in a small car. In fact the 2007 model actually enhanced this feature, incorporating bumpers. Thus the car has grown from 2500 mm to 2695 mm, partly in response to new legal requirements in Europe and the USA. The latest generation of Smart cars has also changed the interior: "a more austere approach has led to greater rationality without compromising the freshness of the design" (Baruffaldi, 2007a). Thus, the original trendy coloured plastics and fabrics, in the best Swatch tradition, are slowly losing their place.

Since 2007, Smart has also produced in an electric version car (figure 131). The first 100 units were leased to UK companies committed to recharging the car solely with electricity from renewable sources. Another 100 cars will be leased to UK users across London, the South East and the West Midlands regions, in preparation for series production, scheduled to start in 2012. (Smart, 2010).



**Figure 131: Smart Fortwo Electric Drive (2008).**

**Technical specifications** | The 2010 Smart Fortwo is available with three different powertrains: petrol, diesel and electric, although the last of these is still restricted to test models, as mentioned before. The petrol engine of the Smart has increased in size and power. Initially it was a 45kW / 50bhp 698cc. The CO<sub>2</sub> emission, however, was reduced. A start/stop function, called the Micro Hybrid Drive, is also available for petrol engines. This system turns off the engine automatically when the car stops, and turns it on again when the brake pedal is released. Smart says it enables a fuel saving of up to 29% in urban settings. The diesel model uses the world's smallest direct-injection diesel engine, delivers 40 kW/54 bhp, and is the world's most fuel-efficient and lowest CO<sub>2</sub>-emitting combustion drive production car. The second generation of the Fortwo also grew in size, from the 2.5 to 2.7 metres.

- Powertrain: 52 to 62 kW (71 to 84 HP); 3 cylinder, 999 cc, in-line petrol engine rear mounted. 40kW (54bhp); 3 cylinder turbo, 799cc in-line diesel engine, rear mounted.
- Architecture: Steel Tridion safety cell, plastic body panels. Cabrio or Coupé.
- Performance: CO<sub>2</sub> emissions: 104 and 120g/km in petrol engines, 89g/km in diesel; Consumption (combined): 62.8mpg and 54.3mpg of petrol, 83.1mpg of diesel; Top speed (petrol): 135 km/h (84mpg); Acceleration (petrol): 0-100 km/h (0-61mph) in 15.5 seconds
- Measurements: Length: 2695 mm; Width: 1559 mm; Height: 1565 mm; Weight: 750 kg (kerb) 1020 (gross)

All data provided by Smart (2010).



The Marketplace | Some competitors of the Smart are presented in figure 132.



Figure 132: Competitors of the Smart Fortwo: Microcar M.Go Electric, Elettrica Electric, Xiaoyi, Nice MyCar Electric, Lumeneo Smera, Mega E-City, Revv G--Wiz and Toyota iQ.

For a long time, Smart was alone in the market as the only brand from a major traditional automotive group to produce microcars. Nevertheless, there were several small independent manufacturers producing microcars with diverse powertrains. From the point of view of sustainability, the future benchmark will be, obviously, electric microcars that are capable of having the lowest environmental impact during use.

Lumeneo, Elettrica, Mega, Micro-Vett and Reva are some of the companies sharing the electric microcar market; however, in most of these cases, the vehicles are categorized as quadricycles. Currently, the Reva G-Wiz is enjoying some success in specific markets, such as in London, where electric cars are exempt from local taxes. However, Reva presents a very poor design that fails to build credibility for electric cars. Other examples from Asia, such as the Chinese Xiao Ya, are even more amateur, and very far from the manufacturing and design standards of the Smart.

Meanwhile, independent studios have proposed some very attractive and well-designed solutions to microcars or to individual mobility in a broader sense, which could create competitors at Smart's level. But the concepts, like the Pininfarina Metrocubo and Nido, have not led to a production car. Designed by Giugiaro, and manufactured in Hong Kong, the electric microcar MyCar presents an interesting option for £8,995 - £1,000 more than the G-Wiz. The price of the Smart Fortwo starts at £7,114.

The Norwegian company Think, once associated with Ford, is expected to launch the City electric car in 2010. Like the original Smart, the body of the City is made of unpainted plastic panels. In the same year, Lumeneo will be selling the Smera in Paris. This small electric quadricycle is half the size of a Fortwo, being only 860mm in width. The Smera leans to corner, like a motorcycle, and has an interesting 1 + 1 seating configuration.

Most of the mainstream companies have avoided attempting to enter this market: on the contrary, their cars continue to get bigger. Toyota, however, is currently challenging the Smart dominance in this niche. The Toyota Iq, on sale from 2008 in Japan and 2009 in Europe, is the strongest competitor so far for the Fortwo. Its price starts at £9,974, but the car offers an extra row of seats, in the back, and occasionally the Toyota can carry four passengers. The overall length is only 2,985mm, and the 998cc petrol engine produces 50kW and 99g/km of CO<sub>2</sub>. The combined fuel consumption is 65mpg. The design might not have such a strong personality as Smart's, but it has good qualities and the packing is very attractive.





Figure 133: Design analysis of the Smart Fortwo.

#### 4.1.5. Driving the Smart

When a car breaks with traditional paradigms, is the driving experience different? What is it like to drive a microcar? More specifically, what is the Smart like from the inside? To answer these questions, and to complete the case study, I rented the car for five days in Sardinia, Italy in 2007 (figures 134-135). It was not the same as living and commuting every day with the car, but was enough to have some driving impressions.



**Figure 134: Smart Cabrio in the narrow streets of Castelsardo, Sardinia, Italy (2007).**

In the rental car park, the Smart looked more stylish than the other available economical cars. The car I chose was a Cabrio. The open top makes a lot of sense in a sunny tourist destination, but is also a feature that brings fun to everyday commuting. Around town, in the typical narrow Italian streets, the Smart was perfect, and I felt comfortable driving and parking beside Vespas, Apes and old Fiat 500s. The car drives through places you wouldn't dare attempting with bigger cars, and the Smart flows through naturally. It gives a feeling of freedom and respect for the city. Driving on the road along the north coast of Sardinia was a different experience. The spacious interior and soft ride made me sometimes forget its size. The car felt nimble and safe on the winding coastal roads, maybe feeling safer than it actually is. The paddle-shifts are easy to use, but not fast. A lot of gear shifting was necessary to keep the power and the car running bravely uphill. Doing that, the performance was good enough, but the fuel consumption, however, was disappointing. An automatic gear setting and a steadier pace are necessary to drive it more ecologically. The journey back was along the highway that crosses the interior of the island. Getting the cross-wind from big lorries and buses on this main road was the only unpleasant experience I had when driving the Smart for these few days. The overall impression was positive, and the microcar proved its logic. Moreover, it was the only time I didn't say afterwards that I rented 'a car'. I rented a Smart. It felt special: rational, stylish and fun.



**Figure 135: Smart Cabrio in Alghero, Sardinia, Italy (2007).**

#### **4.1.6. Conclusion**

Once considered the first car of the 21<sup>st</sup> century, the Smart Fortwo stands as one of the most admired designs of its time, a contemporary icon, inheritor of the legacy of the VW Beetle, the Fiat 500 and the Morris Mini (Bayley, 2008). The Smart symbolises the transformation of a pop culture society to a sustainable society. It symbolises consumer goods being metamorphosed into eco-friendly tools.

The Smart Fortwo is a notable case of a meaningful aesthetic, a consequence of a total design process. Moreover, it has presented a design approach where “the aesthetic of sustainability is not so much an objective, but more a result of systems of design and manufacturing which are consistent with sustainable principles” (Walker, 1997). Thus, the Smart’s contribution to sustainable aesthetics is more a methodology than shapes and lines to be copied; also, because its style is so particular, this cannot be used by other brands without compromises.

The cities of the 21<sup>st</sup> century will, certainly, redesign the car, in an opposite process from that seen in the 20th century. The restriction on space to park will define new standard dimensions of automobiles. When wastage of space is not feasible, microcars will reign. Being the first of its kind, the Smart didn't enjoy all its associated benefits, like new parking layouts, for example. However, Mercedes-Benz’s strategy of making the Smart more upmarket than Swatch would expect, built a positive image of the micro-, eco-friendly car, and paved the way for the arrival of new models, like the Toyota Iq. The more these cars are added to the fleet, the better the city environment, and the lower the overall emissions. With the addition of the electric powertrain, the Smart will be even more sustainable, and the automobile will continue to provide freedom of mobility.

## 4.2. Venturi



Figure 136: Venturi logo.

### 4.2.1. Introduction

Venturi Automobiles is a Monegasque company which produces special cars at small scale. Formerly a sports car manufacturer, the company changed its brand identity to focus on ecological vehicles, but at the same time aiming to preserve the pleasure of driving. In its early days, Venturi's understanding of pleasure was associated with speed. Their cars were built with more power each time to achieve higher performance. Venturi sought for the Myth of Speed following the tradition of the Evolutionary Age: it made fast sports cars and racing cars, and joined Formula 1 for a while. When the company was acquired by Gillo Pallanca-Pastor, there was a revolution, and new paradigms started to be investigated. Venturi's cars of the new era would have to be fast but ecological.

This case study examines the history of the company and its new focus on sustainability, following the work of the designer Sacha Lakic, who is responsible for all new Venturis. The study includes analyses of the new sports car, the *Fétish*, and other two concept cars, the *Astrolab* and the *Eclectic*. Showing concepts and producing ecological vehicles, Venturi has become an important reference point in the development of sustainable design. At EVER Monaco and the Paris Motor Show, where the cars were seen and experienced, it was clearly evident that Venturi, out of all the exhibitors, was shortening the gap between concept and production cars. Venturi was proposing not only a new design language, but also alternative technology and a new understanding of mobility



and speed. Therefore, a case study of the brand was essential to research the aesthetics of the automobile in the Age of Sustainability.

#### 4.2.2. History of Venturi

Venturi Automobiles started its commercial activities in 1984 as a French company. Its first public appearance was at the 1984 Paris Motor Show, demonstrating a lightweight GT car that aimed to compete with those by Porsche and Ferrari. The production of the MVS Venturi 200 (figure 137) began in 1987, succeeded later by the 300 (figure 138). Initially, the car used a turbocharged PRV V6 engine developed as a joint venture between Peugeot, Renault and Volvo, with 200 HP. The power was increased to 260 HP in 1990 and in the next year a cabriolet version joined the portfolio. The cars were typical Wedge Bodies, with a mid-mounted engine and a fibreglass body. In the 1990s the 200 was reworked into the 300, with more of a Smooth Body approach. (Venturi, 2010; Venturi Communaute, 2010)



Figure 137: MVS Venturi 200 (1987).



Figure 138: Venturi 300 (1991).

The style was clearly influenced by Ferrari. The powerful 400 GT, launched in 1993, had similar detailing and lines to the famous F40. The Venturi supercar had 407 HP and was the fastest French road car, reaching 293 km/h (182 mph). The 400 GT was the first

production car equipped with carbon brakes. The Venturi 400 GT (figure 139) was basically a road legal version of the model developed for the Venturi Trophy.



**Figure 139: Venturi 400GT (1993).**



**Figure 140: Venturi LM (1993).**

Venturi's racing car activity didn't stop at this, their Venturi Gentlemen Drivers Trophy, in which around 70 drivers took part. With the 500LM (figure 140) and the 600LM the brand participated in the 24 Hours of Le Mans (*24 Heures du Mans*) race in the mid-1990s. In 1991, the Venturi-Larousse team was unsuccessful at Formula 1. However, in international GT races during the 1990s, Venturi sometimes defeated Porsche and Ferrari.

In 2001 the company was sold to the Monegasque millionaire Gildo Pallanca-Pastor, the largest property owner in Monaco, where the headquarters of Venturi Automobiles are now located. Pastor, himself, also had a motor-racing past. He raced in Europe and the USA and achieved speed records on ice with the Bugatti EB100. When he took control of Venturi, he was following in the tradition of Enzo Ferrari, Louis Chevrolet and others who moved from racing to management of a car company.

Under Pastor's direction, however, Venturi changed its focus towards producing ecological vehicles through the Venturi Positive Energy programme. The new image of Venturi is also associated with its new designer, Sacha Lakic, who was born in Yugoslavia but lives and works in France. Sacha has been Pastor's designer for both Venturi and his Propaganda



Beer company. He designed Venturi's new logo, the five new cars and also a longboard skateboard.

At the beginning of the 21<sup>st</sup> century, Venturi's first models of the Pastor era were launched. The 2002 Fétish Concept and 2003 Grand Prix (figures 141 and 142) were still, however, internal combustion engine cars following the tradition of the brand. From Lalic's idea, the Venturi Fétish, the first car of the new age, was made into an electric model.



**Figure 141: Venturi Fétish concept (ICE) (2002).**



**Figure 142: Venturi Grand Prix (2003)**

The turning point was at the 2004 Paris Motor Show, when the electric version of the Fétish was first shown. Venturi became a 'green company' and claimed to have 'created on the one hand a new segment, that of the electric sports car, and on the other hand carried an extremely positive message for the future of the automobile, composed of high performance and driving pleasure. (...) the Fétish widely changed the public's opinion about the electric vehicle while positioning Venturi among the most accomplished technological companies in the world in terms of mobility.' (Venturi, 2007).

Over the following years, Venturi extended its portfolio to other vehicle categories. The Eclectic proposed a new paradigm for the city car, with no emissions; it even produced its own energy: a new interpretation of the Myth of Freedom. In the same way, the Astrolab concept questioned the principles of motor sport, enhancing the experience through a stronger connection to nature: a new interpretation of Speed. Thus, Pastor and Lacic at Venturi changed the company's image from a small manufacturer to a 'think tank'.

#### 4.2.3. Venturi and sustainability



Figure 143: Venturi's slogan plate.

Venturi's new profile matches Monaco's political intention to transform the principality into a pioneer in environmental policies. Monaco has supported research into sustainability, and it hosted the EVER (Ecological Vehicles and Renewable Energies Conference and Exhibition), where Venturi has often attracted much attention.

To Venturi, developing an ecological automobile has been seen as 'the future of the car industry', and the intention of the company is 'to be ahead of the others', said Marianne Hollande, who is in charge of Venturi's Marketing Department (Hollande, 2007). Since the brand has changed its focus towards producing ecological vehicles, the company has named its sustainability programme Venturi Positive Energy, and has started using the slogan 'Powered by Innovation'. This demonstrates that the primary image the company wants to promote is 'excitement', this being through a high-tech rather than a 'tree hugger' approach. Hollande has declared that the company has a conscious awareness of environmental sustainability that encompasses design, production and use. Thus, Venturi has been associated with the Carbon Neutral Company, which also works with Honda. This organisation carries out a greenhouse gas assessment to establish baseline CO<sub>2</sub> emissions. It then identifies cost-effective ways to reduce CO<sub>2</sub> emissions, and chooses carbon-offsetting schemes to balance the remaining emissions. Through this system Venturi finances wind turbines in New Zealand. Venturi is also seeking ISO 14000 certificate partners.

Nowadays Venturi's portfolio is based on two models, the Fétish and the Eclectic, both electric and clean during use. These models are already currently using photovoltaic, electricity and wind turbine solutions, and the company is researching into hydrogen powered vehicles as a long-term solution. Thus in the future Venturi will probably be using an engine from mainstream companies, like BMW or PSA. (Hollande, 2007)

Although Venturi's scale of production is very small, the impact of the new eco-friendly models on the media has been much bigger than if Venturi was proposing a gas-guzzling sports car. The company expects that these models will pave the way for others, and maybe Venturi will eventually aim for a larger public, accompanying the growth of the sustainable car market.

#### 4.2.4. The Fétish



Figure 144: Venturi Fétish in the streets of Monte Carlo.

**Design story** | The Fétish was launched in 2002 as a four-cylinder, two-litre petrol engine lightweight sports car, in line with the tradition of the brand. The car was a two-seater coupé, with mid-engine and rear-wheel drive. The central structural unit was made of aluminium, and the bodywork in carbon fibre. The Fétish was the first design by Sacha Lakic for Venturi Automobiles, and was not initially based on environmental concerns. However, the concept car did not make it to production with an internal combustion engine. Two years afterwards, the electric powertrain model was shown as the production car. The electric version (figure 141) retained most of the original design.

Nevertheless, there are several differences between the 2002 concept car and the model which went into production in 2007. The latter model is both a roadster and a coupé, in which a panoramic windscreen, integrating the whole rooftop, was proposed. This eliminates the impression of a fake rear window caused by the painting of the rear pillars.

The dual colour solution was also revised. In the concept car, the dividing line between the areas with a carbon fibre appearance and those with gloss painting started at the top of the front light clusters, passed through the top of the front wheel-arches and finished at the middle height of the rear wheel-arches. Now it starts below the new front light clusters and bends down in a curve, finishing in front of the rear wheels. The solution is similar to the Grand Prix model, and gives more expression to the composition of the rear section. The two-colour division has disappeared from the rear end and the carbon fibre appearance features only on the engine compartment's exhaust void. The tail-lights are also new, but the area they take up still looks very small, to achieve a minimum legal standard. The big difference in the rear section is, of course, the absence of the exhaust pipe which is normally seen in a sports car, due to the Fetish's electric powertrain.

Sacha Lakic presented his work on the Venturi website as "conceived to demonstrate that there is an exciting alternative to the petrol engine", but there is no reference to sustainable design as a determining factor in its style, role-played by 'the pleasure of driving' (Venturi, 2007). Actually, the architecture of the car was much more influenced by racing car technology, to obtain the extreme pleasure of driving. It comprised a central unit cockpit and space frame made of carbon fibre and aluminium. The positioning of an electric motor was the same as that of the former internal combustion engine. The bodywork was also made in carbon fibre. The chassis, is composed of a central unit in pressure-sealed composite carbon-aluminium honeycomb, and front and rear units in welded aluminium extrusions. This mix of materials and technologies is typical of a small-scale production high-performance car; the use of lightweight materials is, however, important to achieve lower levels of energy consumption during use. Moreover, the architecture did not reflect an innovative design process, because it was limited by an earlier proposal, and the electric and petrol Fétishes looked almost identical.

**Technical specifications** | This is technical profile of the Fetish according to Venturi (2007):

- Powertrain: 180 kW Electric motor, rear-mounted, air-cooled.
- Batteries: 31 modules of lithium-ion LIV-7 batteries, placed in T formation at the central unit, weighting 248kg. Liquid cooling and braking regeneration system. Battery recharging with external 3-phase charger: 1 hour. Battery lifecycle average of 2000 cycles or 250.000 km.
- Architecture: Central unit cockpit and space frame, in carbon fibre and aluminium. Bodywork in carbon fibre.

- Performance: No CO<sub>2</sub> emissions. Autonomy of 250 km in one charge. Top speed of 160 km/h. Acceleration of 0-100 km/h in less than 5 seconds.
- Measurements: Length 3887 mm, Width 1884 mm, High 1200 mm, Weight 980 kg.

**The Marketplace** | Venturi Automobiles plans to produce only 25 models of the Fétish, which will cost around £200,000: more expensive than a Ferrari. While, the top speed of the Fétish is not impressive for a sports car enthusiast, the acceleration is comparable to the Ferrari and the Porsche. The key point is that the Fétish is an eco-friendly sports car, stylish but ethical, and more than 100 mph may be unnecessary in real-life conditions. Moreover, the buyer of the Venturi will be getting something more exclusive and ecological, not just a high-performance sports car. The competitors of the Fétish will be other electric sports cars.

Currently, the North American Tesla Roadster is the Fétish's major competitor. This sports car, built by Tesla, is essentially a Lotus Elise that has been fitted with an electric powertrain. In design terms, the Tesla is as different from an Elise as a Porsche Carrera is from a Turbo. The Tesla also uses lithium-ion batteries, which are claimed to run for 250 miles - more than those in the Fétish. The top speed of the Tesla is also higher, reaching 160 mph, but the power of the engine is almost the same as the Fétish, 185 kW (248bhp). Like the Elise, the Tesla has a chassis made from aluminium extrusions that have been bonded together. Although the body volume is almost the same of the Elise, every detail has been reworked in the Tesla, reducing the number of curves that identified the Elise. At the price of US\$100,000, it will be a difficult rival for the Fétish if Venturi is planning to sell it in California. (Jordan, 2006)



Figure 145: Competitors of the Venturi Fétish: Audi E-tron and Tesla Roadster.

Whilst the production of the Tesla and the Fétish were announced years ago, the cars are being launched on the market slowly. In the meantime, Audi unveiled plans for an electric version of its R8, in 2011. As with the Fétish and the Tesla, the design was based on a car from the company's current portfolio. The Audi E-tron will be built alongside the R8 and the Lamborghini Gallardo. The production volume will be significant: in the first year, Audi will build 100 units, to be leased to customers; and for 2012, the goal is 1000 vehicles for lease and sale. Customers will be paying at least £100,000 for Audi's experimental vehicle. (Kacher, 2010)

**Design analysis** | The design of the Fétish presents several features that are common to ecological cars, such as the visual distinction of function and materials. However, the colour composition, based on painting, is also seen in sophisticated and unsustainable cars, like the Bugatti Veyron. The two cars also share some characteristic shapes and surfacing, maybe because both have sought references in the traditional French sports car. Thus, the exterior presents a Conservative approach to the aesthetics of sustainability, with references to Carved Body and New Classic styling. In addition, Sacha Lakic's design language links the car to Functionalism. The best part if the detailing is integrated in the aesthetic proposal, mostly from functional parts. When in the frontier between luxury and functionalism, the language becomes confused - see front-light clusters on figure 147. This near-functional language continues in the interior (figure 146), where a Spartan look seems to suit an ecological car, as harmonically as it does to supercars. The Fétish interior looks, however, more sophisticated than that in the Ferrari F40.



Figure 146: The interior of the Venturi Fétish.



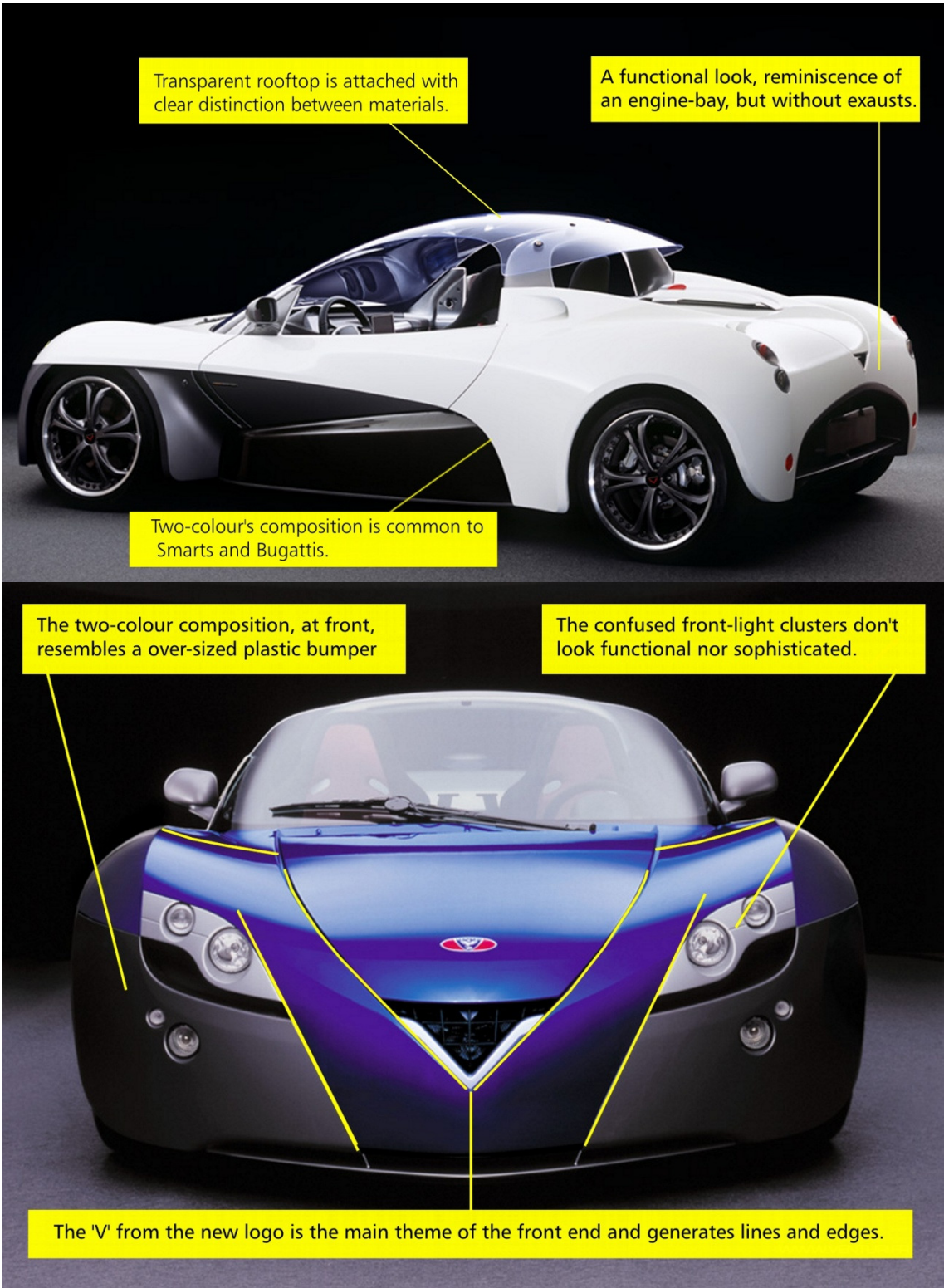


Figure 147: Design analysis of the Venturi Fétish.

#### 4.2.5. The Astrolab



**Figure 148: Venturi Astrolab concept (2006).**

**Design story** | The Astrolab (figure 148) was launched as a concept car in 2006, aiming to be the first commercial high-performance solar vehicle in the world. Later, Venturi changed its plans and decided to keep the model only as a concept. (Hollande, 2007)

The car was conceived as a different kind of hybrid, using electricity from both the grid and its own solar panels. Thus the car was able to recharge its nickel-metal hydride batteries even when in motion. For this reason, the Astrolab incorporated 3.6 square metres of photovoltaic cells and was covered by a film composed of nano-prisms that, according to Venturi (2006), would enable a denser concentration of solar energy. The plug-in hybrid with solar panels adopted an 18kW electric motor that could give the car a top speed of 120 km/h. This unimpressive performance did not worry Venturi: the Astrolab approached sport ecologically, and the pleasure would be gained from driving with a close connection to nature, as sailboat does. (Venturi, 2007)

Venturi's design is comparable with a Formula 1 car, because of the use of a carbon fibre monocoque chassis that works as an oversized protection cell for the driver and passenger, who sit in a 'fighter jet' position. The centralised cockpit also recalls a Formula 1 car, and the architecture and design, with minimum unnecessary additions, make the cockpit predominant in the design concept, an example of the Cockpit Body trend. Moreover, the design language followed the function.

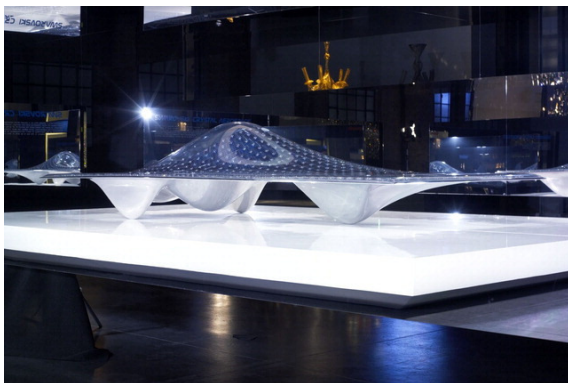
Although the designer Sacha Lakic (2007) described it as "a flying wing set on four wheels", the car did not look as though it was born in a wind tunnel, when compared to solar racing cars. The difference lay in the hybrid concept that allowed the Astrolab to be less efficient than a solar racing car, which is extremely aerodynamic. Although a solar



racing car, like the champion model from the Nuna / Nuon Solar Team (figure 149), might have an interesting and aggressive shape, it does not connect to the tradition of car design in the way that the Astrolab does. The Venturi Astrolab showed an aesthetic that was not far from contemporary car design trends, a considerable achievement in terms of a solar-powered car. Another concept for a solar-powered car, designed by the Welsh designer Ross Lovegrove and presented at the 2006 Milan Design Show, was the Swarovski Crystal Aerospace Car (figure 150), that showed a daring organic design, uncompromisingly inspired by solar-powered racing cars, with large transparent surfaces, but was hardly recognizable as a car.



**Figure 149: Noun Solar Team Nuna 3 solar-powered racing car (2004).**



**Figure 150: Swarovski Crystal Aerospace Car.**

In contrast to the *Fétish*, the *Astrolab* was designed from the beginning to be an ecological car. Both cars can be considered roadsters, but the *Astrolab*'s architecture was compromised much more by the technical requirements of making it sustainable, most significantly in this context being the use of photovoltaic panels. Nevertheless, it seems that the *Fétish*'s design was constrained in a stronger way than the *Astrolab*'s, where the requirements do not limit but on the contrary enhance the creation of a surprising aesthetic.

**Technical specifications** | This is technical profile of the Astrolab, according to Venturi (2007):

- Powertrain: 16 kW Electric motor, air cooled.
- Batteries: NIV-7 Pack (Nickel-metal hydride) 72V, liquid cooling. Mass; 108 kg. Full recharge in 5 hours with standard 16A plug. Battery lifecycle: 10 years (2,500 cycles)
- Solar Panels: 3.6 square metres of photovoltaic cells. Power: 600 W.
- Architecture: Central carbon fibre body with front end rear units in aluminium. Bodywork in carbon fibre.
- Performance: No CO2 emissions during use with the possibility of generating its own clean energy. Autonomy on batteries of 110 km with the addition of 18 km per day from the solar panels. Top speed: 110 km/h
- Measurements. Length: 3800 mm. Width: 1840 mm. Height: 1200 mm. Weight: 280 kg (empty)

**Marketplace** | Venturi's initial plan was to produce the Astrolab in small scale, but it will remain as a concept car. Thus the Eclectic will be the first car in production with solar power. Nevertheless, the Astrolab has been useful for Venturi as a marketing tool. Considering that Venturi's actual portfolio consists of two cars, which will be sold in very small numbers, just 225 cars in total, a concept car can be as important, or even more so, than production models. The Astrolab demonstrates Venturi's intention of producing an ecological and pleasant sports car with surprising architecture and innovative style, and has delivered the message more effectively than the Fétish.



**Figure 151: Two other concept cars with a Cockpit Body: Rinspeed Exaxis and Giugiaro VAD HO .**

Concept cars are important to create future design trends that might appear in production models. Some of the design features of the Astrolab can also be seen in other ecological concept cars. The Cockpit Body trend appeared in the Giugiaro VAD.HO (figure 151), a concept car that used a BMW hydrogen-fuelled V-12 with aeronautic references. Another

new concept presented at the 2007 Geneva Auto Show, by Swiss company Rinspeed, the Exasis (figure 151), used a transparent polycarbonate skin to lighten the weight of the car and presented the body volume of a Formula 1 car from the 1950s. The central seating positioning has been a recurring trend in eco-friendly concepts, partly because it reduces the frontal area and improves aerodynamics. However the aesthetic of the Astrolab is more influenced by Lakic's motorcycle designs, making it comparable to the new roadster by KTM, the X-Bow, which is by no means a sustainable car. In contrast to the X-Bow, the Astrolab offers the notion of a sustainable sports car that doesn't depend on high-speed thrills: Venturi compares it with a sailing boat which gives an exciting, silent and clean ride, "making the best use of the elements provided by Nature"(Venturi, 2007).

**Design analysis** | The Astrolab's design was strongly defined by its solar panels, which created a top layer (see figure 153), comparable with a wing by Venturi, but very straight and simple, without the sexy lines of a Ferrari or the surprise volume of the Swarovski Crystal Aerospace car. Sacha Lakic's functional aesthetic referred to his previous work on motorcycles. The aerodynamic solution was not radical, and the wheels were exposed without bigger compromises. Moreover, the squared profile (see figure 152) hides the lightness of its Cockpit Body. The Astrolab, categorized as a quadricycle, might not be the most daring concept shown in the last few years, but presented very interesting architecture and aesthetics and an exciting future for motoring as a sustainable practice.

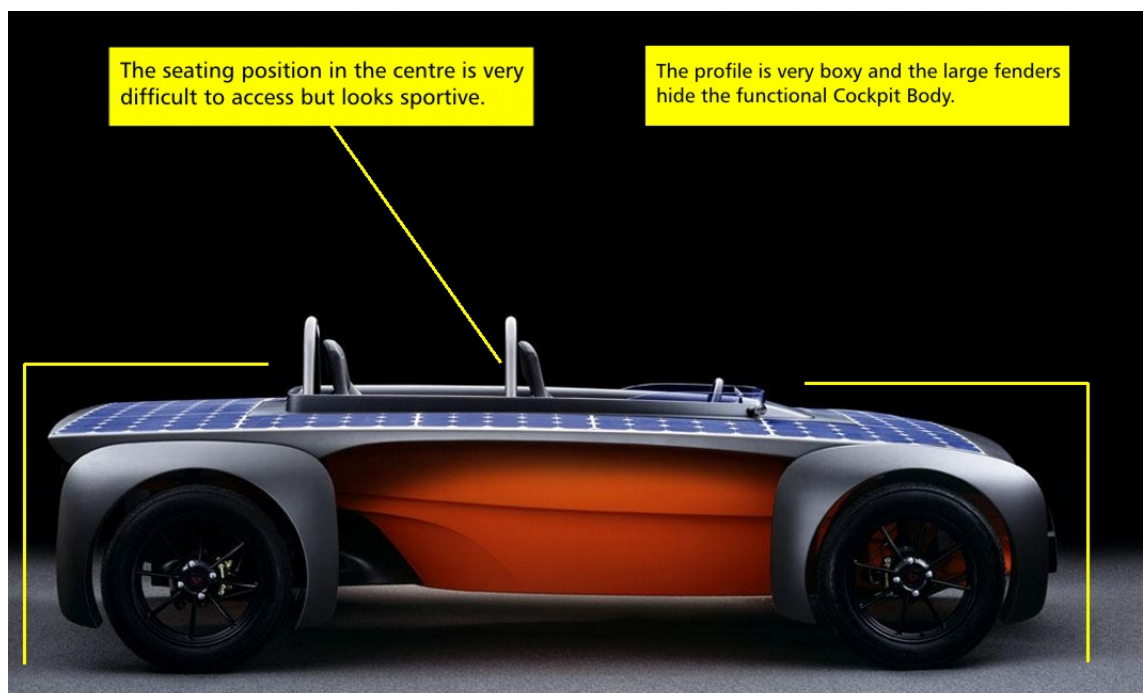


Figure 152: Design analysis of the Astrolab.

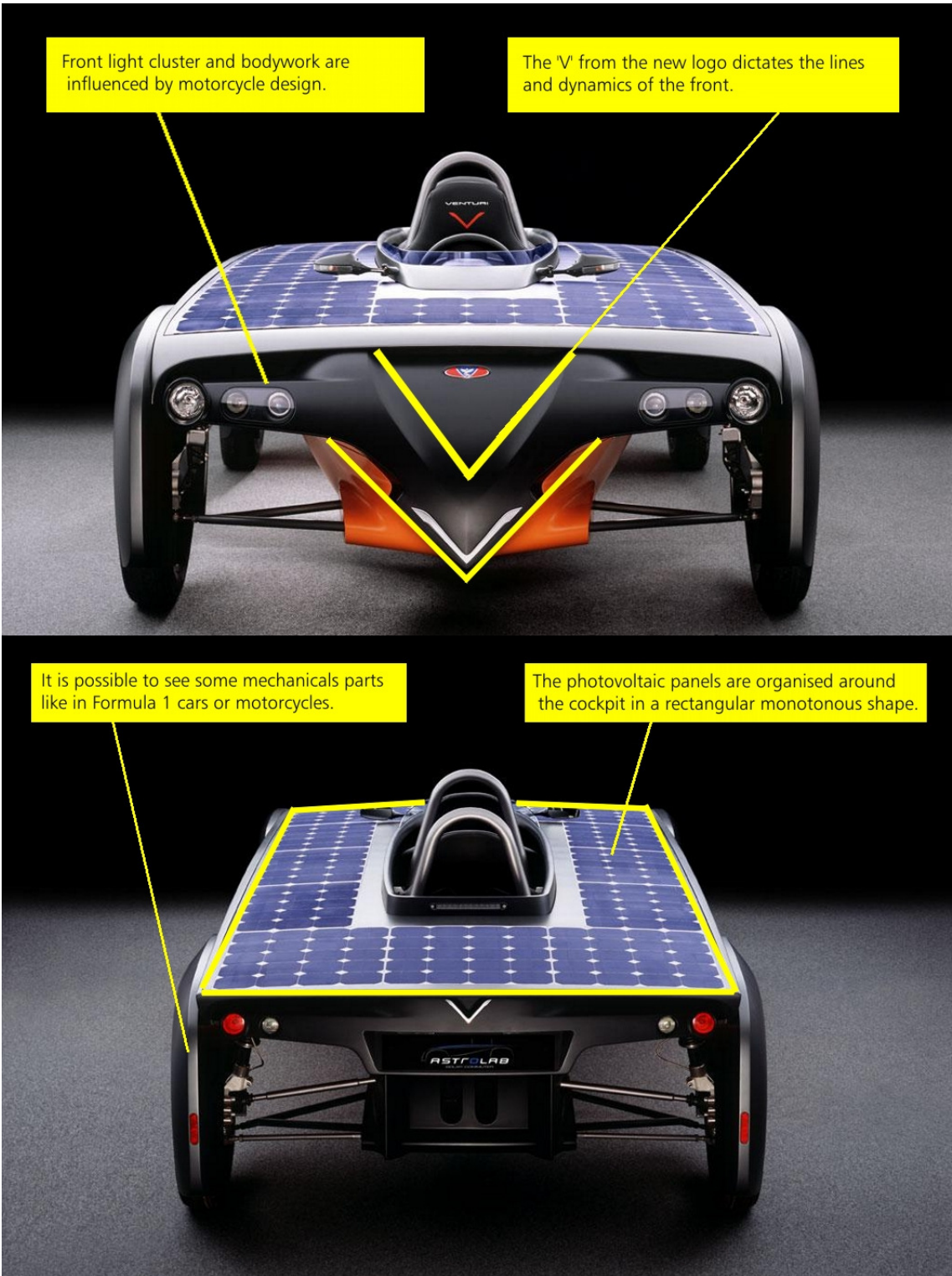


Figure 153: Design analysis of the Astrolab.



#### 4.2.6. The Eclectic



Figure 154: Venturi Eclectic concept (2006).

**Design history** | The first commercial hybrid electric solar-powered car is not going to be the Astrolab, but the Eclectic. Venturi first presented the concept in 2006 (figure 154), and in 2009 showed the model that will hit the road in 2010 (figure 155). The concept behind the design was to create a “modern, autonomous and intelligent automobile” that uses the energy that exists around it (Venturi, 2007). The designer Sacha Lakic made use of 3 different energy resources: solar panels, wind turbine and electricity. Thus, like the Astrolab, the starting point for the design was the positioning of the photovoltaic cells. The roof of the Eclectic is long, and gives the car a boxy look. However, the photovoltaic cells were integrated into a transparent roof, which created a pleasant lighting effect in the interior. The same solution can be found in the German Solarshuttle 66 solar boat (figure 156). As with the solar boat, the volume is clearly divided in two, a chassis or platform and the cover. The small wind turbine is only attached to the car when it is parked, so that it may produce even more energy than the solar panels.



Figure 155: Venturi Eclectic production model (2009).

Like the Astrolab, the Eclectic is considered a quadricycle; thus, several mandatory features common to production cars are not required to be taken account, which helps to create a more unusual aesthetic. In addition, Lakic (2007) said that its design was influenced by distant references like the Lunar Rover and the Citroen Mehari (figure 157). The Eclectic's volume and exposed wheels also brought back memories of horse-drawn carriages. One way or another, its aesthetic is not closely connected to internal combustion engine cars, which was Venturi's main intention. According to Lakic (2008), the design language of both the concept and the production model reflected its function. In detail, the concept presented a cruder approach to Functionalism, and the production model is smoother.



**Figure 156: Solarshuttle 66.**



**Figure 157: Citroen Mehari.**

The architecture, with a technical skateboard, allowed for a free organisation of the interior. In the concept, three equal seats, made of plywood, were arranged with one in the centre at the front and two in the back, offering considerable space for a car that is only 2.86 metres long. In the production car, the basic arrangement was maintained, but the seats blended together, and the overall length was reduced to 2.78 metres.



**Figure 158: Venturi Eclectic (2009).**

The production model (figure 158) had the skateboard platform redesigned to facilitate access to the interior. The space frame tubes are now only seen from the inside. The windscreen was angled, giving more dynamism to the volume. The wheels are now better protected and the association with historic carriages diminished. According to Lakic (2009), the compact silhouette and friendly appearance indicates the characteristic respect for the city that Venturi expressed with the Eclectic.

There were neither hard doors or glass in the sides of the first concepts, which helped to lighten the weight of the Eclectic but also limited its use. However, Venturi is planning to add the option of hard doors to the production car. Meanwhile, the vehicle will be categorized as a heavy quadricycle and can be driven in Europe from the age of 16.

**Technical specifications** | This is the technical profile of the concept car, according to Venturi (2007).

- Powertrain: 16 kW Electric motor, air cooled.
- Batteries: NIV-7 (Nickel-metal hydride) 72 V. Liquid cooling. Mass: 108 kg. Recharging system when braking. Battery autonomy: 50 km. Battery life-span: 2,500 cycles or 10 years. Full recharge in 5 hours with onboard charger.
- Solar Panels: 2.5 square metres of photovoltaic cells. Power: 330 W
- Architecture: Aluminium structure, frame in composite materials, steel engine cradle. Bodywork in composite materials.
- Performance No CO<sub>2</sub> emissions during use. Average solar contribution to autonomy: 7km per day. Average wind contribution to autonomy 15 km per day. Top speed: 50 km/h

- Measurements: Length 2860 mm. Width 1850 mm. Height: 1750 mm. Weight: 350 kg (empty)

This is the technical profile of the production model, according to Venturi (2010):

- Powertrain: 9 kW Electric motor.
- Batteries: [Option 1] Trojan 48 V(Nickel-metal hydride) 145 Ah; liquid cooling; autonomy of 50 km; life-span of 500 cycles. [Option 2] Lithium 48 V - 240 Ah; air cooling; life-span of 1200 cycles. Both options to recharge with onboard charger.
- Solar Panels: 0.8 square metres of photovoltaic cells. Power: 72W
- Wind turbine: Power: 300W.
- Architecture: Tubular steel, steel engine cradle. Bodywork in composite materials.
- Performance No CO<sub>2</sub> emissions during use. Average solar contribution to autonomy: 2km per day. Average wind contribution to autonomy 15 km per day. Top speed: 45 km/h
- Measurements: Length 2783 mm. Width 1659 mm. Height: 1679 mm. Weight: 390 kg (empty).

**The Marketplace** | Venturi is planning to produce 3000 units of the Eclectic annually, which will be priced at 15,000 Euros. The target market is not the general public. Initially, Marianne Hollande, from Venturi's marketing department, stated that the car will most often be used by wealthy customers in private properties, in small tourist cities, like Monaco, or by "companies wanting to adopt an environmentally-conscious stance" (Venturi, 2006). When the production model was finished, Venturi decided to open it up to a broader market, including private individuals, for their daily transportation; young people who can drive from the age of 16, and car-sharing fleets. (Venturi, 2010).

Thus the Eclectic's market rivals (see figure 159) must be other quadricycles and electric cars, rather than mainstream popular cars. Nevertheless, Venturi expected to battle with the Smart Fortwo. At 2007 EVER Monaco it was shown beside its market rival, the GEM e4, by Global Electric Motorcars. Unlike Venturi, GEM has been associated with a mainstream car company, Daimler Chrysler, thus creating the opportunity of enhancing its production scale if market demands increase. But compared with the Eclectic, the e4 made no interesting use of materials, and appeared to be one single piece of fibreglass. At the 2008 Paris Motor Show, GEM showed the new e2, with an exposed structure, like that in the Eclectic. In addition, the e2 was adapted to carry bicycles.





Figure 159: Competitors of the Venturi Eclectic: GEM e4 and e2 with bicycles, Ligier electric and the Renault Twizy Z.E. concept.

Venturi's intention with the Eclectic is to leave behind the insignia of a golf cart and create a new option for urban mobility. The small electric car by Ligier is also moving in this direction, and attempts to refer to automobile design language, while the Venturi is more innovative. Venturi's idea is that the Eclectic is an avant-garde solution to transport people around cities, and the company expects to produce the model on a larger scale in the future, and probably develop a family of vehicles from it.

**Design analysis** | The Venturi Eclectic concept presented an attractive design solution for an ecological vehicle. The design was not constrained by aerodynamics, because the vehicle was designed to travel at low speeds. The boxy volume, together with the skateboard architecture concept, also allowed a spacious interior. Sacha Lacic (2007) said that its design, like the Astrolab's, was strongly influenced by his own motorcycle design practice, from which he borrowed the multi-functionality of every part and the minimalist solutions, aiming primarily to lighten weight. The composition of materials and colours enhances its Functionalism and defines the aesthetic of the Eclectic, one of the best features of the concept being the use of plywood. Aesthetically the Eclectic concept was a

long way from internal combustion engine cars, which was Venturi's main intention, and its innovative architecture was decisive as a result. Most of the principles of the concept were retained in the production model, which, however, looks more nimble and civilized.



Figure 160: Design analysis of the Venturi Eclectic concept.



Figure 161: Interior of the Venturi Eclectic concept.

#### 4.2.7. Driving an electric car

The adoption of an electric powertrain will change the experience of travelling and driving. Consequently, it might give a new understanding to the Myth of Speed. Venturi Automobiles is leaving behind the traditional approach, and moving towards one of sustainability. The question is: how impressive is the new driving experience? What is it like to drive an electric car? To answer some questions and to complete the case study, I searched many times for opportunities to drive an electric car, especially in the 2007, 2008 and 2009 editions of the EVER Monaco Conference, where electric cars were available for testing. Among these electric cars was an Eclectic concept car; the Fétish and the Astrolab were never available.

The general impression of driving an electric car, from models by Think, Mitsubishi, Mycar and others, is that the electric cars are agile, having a better response to acceleration than most ICE models, and are simple to drive, silent, and leave more opportunity for paying attention to the road, and for feeling a connection to it. Good acceleration is a frequent benefit of the electric motor that will only make the sports car more exciting.



In addition, I tested the Eclectic, and felt the pleasure of using an open vehicle, in an appropriate environment such as Monaco. It is evident that this typology may have a future, with social benefits, when traffic will become more civilized and clean.

#### **4.2.8. Conclusion**

Venturi is creating its new brand identity from the production of ecological cars. It is not in the same situation as a mainstream company with a distinct tradition, many customers and large industrial plants to be redesigned. Thus, according to Sacha Lackic (2007), Venturi can react quickly to the changes in the market and in society, because of its size and management flexibility. The freedom to design was decisive, and its daring solutions can be used as a testing-ground for bigger companies, that are certainly observing the impact of Venturi's cars on the market.

The direction of sustainable design is considered by Venturi to be the right one, and the only future for the car industry. The strategic decision of the marketing department to make sustainable design 'readable' suited Sacha Lakic's search for a functional design, which can bring excitement without putting on unnecessary weight, for him the biggest problem for today's cars. Lakic (2007) also observed that "it is wrong to make ecological cars' style too futuristic and different because they are very close to being the reality". But most important at the moment is the battle with electric cars' negative stereotype. For Venturi, an ecological car does not need to be ugly and boring. Thus, Venturi aims to rewrite the history of the car by putting fun, innovation and sustainability all together in the same package. Also according to Lakic (2007), the different aesthetics of the Fétish, Astrolab and Eclectic means that "we can or cannot mix style with technologies". He believes that the tradition of car design will strongly influence ecological vehicles, especially for mature companies, and as technologies are available to everyone, brand identity will continue to be the recognizable gene. For Lakic a change in style is not strictly necessary, but is instead good design practice. Thus the new Venturi aesthetic is more a consequence of coherent design than an intention in itself.

Of course, Venturi will face many questions typically asked of electric cars. How will the batteries cope with extreme temperatures, dust, and moisture? What effect will the number, sequence, and duration of charge cycles have? How do owners access and replace sub-par batteries? How often will software updates be required? But Venturi is stepping ahead of the others, and developing exclusive products, for a discerning customer willing to cope with these restrictions.

The success of the cars from Venturi's Pastor era also attracted the attention of major automotive suppliers. As a result, Venturi started a close technological collaboration with Michelin, resulting in the Venturi Volage (figure 162), presented for the first time at the 2008 Paris Motor Show. This new sports car concept is much more revolutionary than the Fétish.

The novelty of the Venturi Volage is in the wheels. The new Michelin Active Wheel technology incorporates two electric motors per wheel: one motor for the active suspension and other for the drive. All eight electric motors are managed by electronics.

The design is based on the Fétish, with which the Volage shares some of its parts. Whilst the style is conservative, viewing from the top, the absence of the mid-engine allowed Lakic to design the bottom of the car to improve its aerodynamics. Moreover, the Volage showed the world that Venturi has moved from being a small manufacturer of sports cars to an ecologically responsible and influential brand, with research into high technology and aesthetics, a reference point in the Age of Sustainability.



**Figure 162: Venturi Volage concept (2008).**

### 4.3. Prius



Figure 163: Toyota logo.

#### 4.3.1. Introduction



*"From now on, I want everybody to put their efforts together and unite in finding a way to make superior vehicles". (Toyota, 2007)*

Figure 164: Toyota Prius (2009).

The words of Kiichiro Toyoda, founder of Toyota Motor Corporation, were the motto for the development of the Prius (figure 164), which can be considered the best-selling ecological vehicle in the world. The Prius was launched in 1997 with hybrid technology, which enables the achievement of considerably low emissions of CO<sub>2</sub>. Hybrid electric internal combustion engine cars are being seen as the best intermediate solution to the sustainable car, the Prius being its benchmark.

According to Hasegawa (2008), when Toyota reached the dominant position of being the world's largest automobile company in sales terms, Katsuaki Watanabe chose to 'downplay' quantitative goals, emphasising basic execution and improvements in quality. In 2007, Toyota was also the most profitable car maker and the eighth largest company, by revenue of US\$179 billion, in the world. Moreover, Watanabe stated that 'Toyota must not only focus its technological development on the environment, safety, and energy, but remain as an exemplary manufacturing company in terms of quality, cost, and human resources development'.

Toyota has an enormous product line, from small cars to big sedans, and the luxury brand Lexus. Together with a number of ecological cars, the company also produces the big Tundra pickup. These circumstances made Toyota's sustainability policies be seen as hypocrisy (Hasegawa, 2008). Nevertheless, the Toyota Prius impacted on the market and imagination of the general consumer in a way that no other ecological car has done before. If the Myth of Comfort in the Age of Sustainability will relate to a respect to others and the environment, the Prius is a step ahead. This case study investigates the true story of a vehicle that is changing the paradigm of a family car.

#### **4.3.2. Toyota and sustainability**

Observing below the first four principles of Toyota it is possible to identify a strong connection to sustainability.

- 1. Honour the language and spirit of the law of every nation and undertake open and fair corporate activities to be a good corporate citizen of the world.*
- 2. Respect the culture and customs of every nation and contribute to economic and social development through corporate activities in the communities.*
- 3. Dedicate ourselves to providing clean and safe products and to enhancing the quality of life everywhere through all our activities.*
- 4. Create and develop advanced technologies and provide outstanding products and services that fulfil the needs of customers worldwide.*

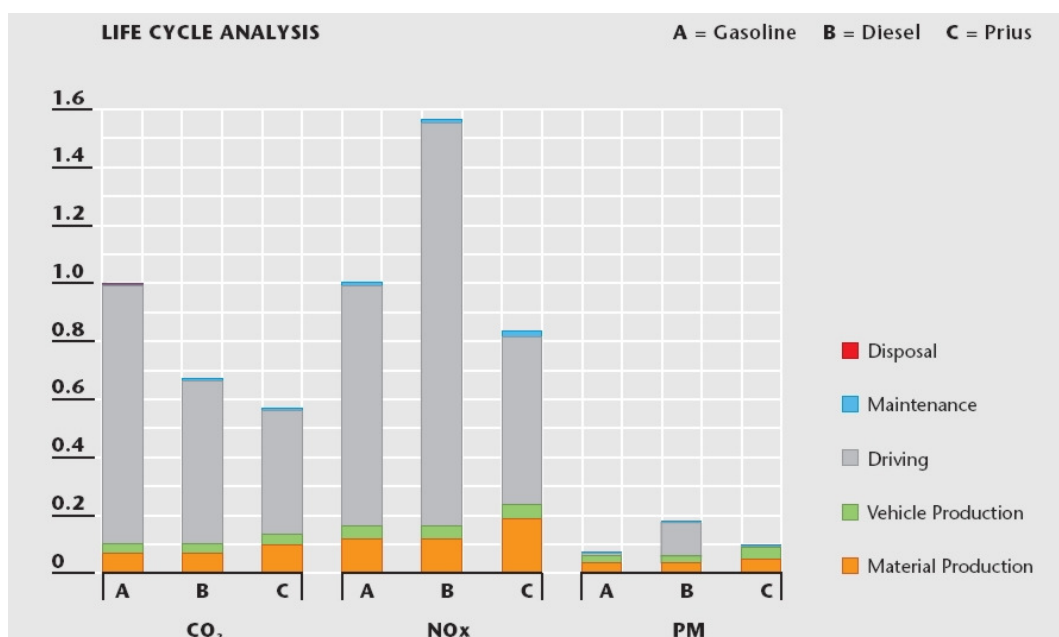
*(Toyota, 2006)*



Figure 165: Toyota's hybrid technology plate.

Although Toyota has been widely criticised for using the 'green flag' as a marketing tool, rather than developing new products that really benefit the environment, at least in theory, the environmental concerns of the company seem to be evident. Toyota is making an effort to reduce pollutant emissions in all areas of activity. The company developed the Eco-Vas, a programme to assess a vehicle's whole life cycle, from design and manufacturing to its use on the road and eventual disposal or recovery, in terms of its impact on the environment. Toyota's product and technology development is focusing on ways to "Zeronize" the impacts and "Maximize" benefits such as comfort and excitement. In the UK Toyota has reached an important zero waste to landfill; the new Prius is consuming less energy during manufacturing, and it has reduced by 31% its CO<sub>2</sub> emissions. ISO 14001 certification has also been consolidated. In terms of recycling Toyota is following the guidelines to ensure 85% re-use and recovery by 2006, aiming for 95% by 2015. (Toyota, 2007)

Table 9: Comparative table of life cycle analyses of the Prius and equivalent ICE cars, petrol and diesel (Toyota, 2007).



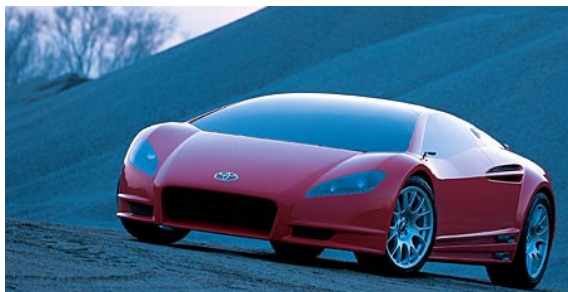


Moreover, the anticipated life cycle of the Prius demonstrates Toyota's intention of making long lasting products, with a planned warranty for every hybrid system component of 8 years. Nowadays, the Prius is the world's best-selling hybrid, both attracting customers to ecological cars and prompting jealousy in their marketing rivals. Significantly, a worldwide switch to hybrid cars would immediately reduce petrol consumption by two-thirds (Hasegawa, 2008). After the Prius, this hypothesis started to be taken seriously.

Toyota's effort to develop ecological cars has not been not limited to the hybrid. From the 1960s, Toyota's engineers got to work developing gas turbines, rotary engines and electric cars, mainly as research projects. But it was the combination of the 1973 Oil Crisis and the 1970 Clean Air Act that enhanced the importance of alternative powertrains to every car manufacturer. After a period of trial and error, Toyota succeeded in controlling the emissions of their cars. It was through the hybrid powertrain, however, that Toyota achieved its avant-garde status (Hasegawa, 2008). The Prius is the main product, but there are other concept and production cars helping to create Toyota's new image.

#### **4.3.3. Toyota's ecological portfolio**

Apart from the Prius, Toyota has consistently presented ecological concept cars. Therefore, it is possible to foresee the future of its design and research departments developing in a sustainable direction. In 2004, Toyota, together with the Italian designer Giorgetto Giugiaro, presented the Alessandro Volta concept (figure 166). The brief for the design was to combine the long-established Italian supercar design tradition with hybrid technology. The result is a Conservative, well-resolved sports car body, but with no reference to a new aesthetic. The car also failed to relate to the usual Toyota line-up, resembling merely another experiment by the Italian designer in the field of supercars.



**Figure 166: Toyota Alessandro Volta concept (2004).**



**Figure 167: Toyota FT-HS concept (2007).**

Closer to Toyota's normal target market was the FT-HS (figure 167), another sports car concept, with a hybrid engine, unveiled in 2007. Whilst the design seemed influenced by North American muscle-car, like the Chevrolet Camaro and the Ford Mustang, it also suggested a competitor to the Nissan GT-R, with a glimpse of ecological awareness.

In another direction, in 2009 Toyota showed the electric version of the Iq (figure 168). The minicar, observed before in the Smart case study, was another important addition to the lines on the market. And soon after (the Iq's) birth Toyota unveiled its intention of producing both a hybrid and an electric version, to make it even more sustainable.



**Figure 168: Iq electric concept (2009).**

More radical, however, was the I-REAL (figure 169) concept, shown for the first time at the 2007 Tokyo Motor Show. This single-person vehicle was almost impossible to classify within the current range of vehicle typologies. Toyota's president, Katsuaki Watanabe, defined it as the 'next-generation synthesis of man and machine'. The tiny electric vehicle was designed to be used, ideally, on pavements, in bicycle lanes and on the open road. The fact that Toyota, a giant car company, presented such a revolutionary vehicle demonstrates its capacity to develop paradigm shift vehicles, and to adopt its portfolio to

provide alternative solutions to mobility. Also interesting is the Fine T concept (figure 170), that presents an inclusive design solution to improve accessibility, and benefits from new vehicle architecture. Meanwhile, the Hybrid X (figure 171), from 2007, was used as a lab to test future design themes for the new Prius.



Figure 169: Toyota I-REAL concept for individual mobility (2007).



Figure 170: Toyota Fine T concept (2006).



Figure 171: Toyota Hybrid X concept (2007).



**Figure 172: Toyota Highlander Hybrid (2007).**

By 2019, Toyota expects to have hybrid options for more than 78% of its portfolio. Most of the hybrid models marketed now by Toyota have the same body and style as the internal combustion model, the hybrid element referring merely to the engine option. This is the case with the Toyota Highlander (figure 172) and all the Lexus hybrids. But it should be noted that the Prius is, in reality, the car which is more focused on sustainable mobility. The Lexus and the Highlander models are automobiles with powerful engines, where the electric motor helps, at the same time, to enhance their performance and to lower CO<sub>2</sub> emissions. Maybe this is the reason for Toyota to establish two different aesthetic directions for the Lexus and the Prius.

#### **4.3.4. The Prius**

**Design story |** At the 1995 Tokyo Motor Show, Toyota unveiled its first concept for a hybrid car, called the Prius, a name taken from the Latin word meaning 'to go before'. The concept was the result of the G21 Project, started in 1993 - G standing for 'generation' and 21 to indicate the coming century. 'It was to be 'zero base' research, meaning that its members would be discouraged from looking to the past for cues, so as not to be shackled by it' (Hasegawa, 2008). The intention was to create, and then set the standard for, the aesthetic appearance of a mass-market sedan in the coming century. The project also incorporated the challenge by Toyota's president, Shoichiro Toyoda, to face the critical comment that 'Toyota cars are boring, and they all look the same.' (Hasegawa, 2008). After five months, the G21 group established that the future car should be 'low on environmental impact and high on efficiency. Initially, the ambition was to build a compact vehicle, with long wheelbase, high roof and spacious cabin, and a high efficiency 1.5 litre engine. At the same time, in the EV development unit, there was a project to develop a hybrid engine system, passionately supported by the executive vice-president, Akihiro Wada.' (Hasegawa, 2008) The hybrid powertrain already had a long history,

studied in section 2.1.9. of this research; however, the it was the Prius that made it mainstream.

The first Toyota Prius (figure 173) was launched in 1997. This ecological family car had a 3-box volume, with a hybrid engine, combining a small capacity petrol engine with an electric motor. The hybrid powertrain boosted power and lowered both fuel consumption and emissions. Even though the first model had not enjoyed the same market success as the 2004 model, the Prius was elected in 1997 the Japanese Car of the Year in 1997. Two months after the launch of the Prius, the United Nations Framework Convention on Climate Change was held in Kyoto, resulting in the Kyoto Protocol. The context was changing, and the Prius was ahead of the competitors. The initial planned production of 1,000 cars a month had to be increased to 2,000, in spite of its high price.



**Figure 173: Toyota Prius (first generation, 1997).**

After the release of the first generation Prius, the engineers at Toyota continued to improve it. In 2003, the new and much-improved model was ready. To achieve a better performance, Toyota developed the Hybrid Synergy Drive, consisting of a transmission system with two halves – a combustion engine and an electric motor – that operate in tandem. Moreover, the addition of a boost converter more doubled battery voltage, increasing the power without increasing the size (Hasegawa, 2008). From 0 to 9 mph the battery supplies the energy, and the car runs on the electric motor. This makes the car silent and clean in urban traffic situations. At cruising speeds the combustion engine moves the car and recharges the batteries. Whenever the car needs extra power, the electric motor assists it. When the car reduces speed, the electric motor captures the energy and recharges the batteries. Thus, the hybrid achieves good performance standards without compromising fuel consumption, and with low CO<sub>2</sub> emissions (Toyota, 2006).



The second Prius (figure 174) was designed as a stand-alone hybrid, its body design independent of other Toyota models. It has changed from being a 3-box sedan to a hatchback, with almost an MPV volume. Because of its aerodynamic shape, it was instantly associated with the idea of an ecological car. The rooftop was thus designed to achieve a considerably low drag coefficient of just 0.26 (Toyota, 2007) following the ideas of Kamm/Koenig-Fachenfeld, as seen in Section 2.1.13 of this research. According to Toyota (2007), the aerodynamic body volume was the basis of the Prius's ability to achieve 'dynamic, futuristic styling, and yet to remain a highly practical car'. Thus, a long wheelbase created a large interior space for a five-seater family hatchback. The major concern for Toyota was to design a car that could demonstrate its innovative technology through style. Toyota's marketing strategy, giving extra value to its environmental achievements, may look mercenary at first glimpse but there is actually no fault in making technological advances legible.



**Figure 174: Toyota Prius (second generation, 2004).**



**Figure 175: Toyota Prius (third generation, 2009).**

The second generation of the Prius had a Minimalistic body. The surfaces were basically clean and plain. The approach was changed in the third generation (figure 175), that showed the typical Carved Body detailing, that was common to other contemporary Toyota and Lexus models. The beltline of the 2009 model was enhanced, and the shoulders helped to lighten the rear section, where the rear wheel arch still seems small.

With less Minimalism and more emotional styling details, Toyota tried to move the Prius from what Don Sherman (2009) called its 'nerdy-looking' style. The car's trademark remained its volume, the K-car line; however, with the launch of the new Honda Insight, this feature became a shared character of the hybrids. The petrol engine grew to 1.8 Litre, but the CO2 emissions were reduced. Moreover, Toyota demonstrated its intention of producing a Plug-in version of the last generation Prius that would bridge the gap till the arrival of the EV.

**Technical specifications** | This is the technical profile of the 2004 model (Toyota, 2007):

- Powertrain: Hybrid electric combustion engine. 77 kW (77bhp) 1.5L petrol engine combined with 50 kW (68HP) electric motor.
- Batteries: 168-cell Nickel metal hydride (NiMH)
- Architecture: Steel monocoque . Kamm/Koenig-Fachenfeld body style.
- Aerodynamic drag coefficient: 0.26
- Performance: CO2 emissions: 104 g/km. Fuel consumption: 65.7 mpg (4.3 L/100km) .Noise dB(A): 69. Top speed: 106 mph (170 km/h) Acceleration: 0-60 mph in 10.9 seconds
- Measurements: Length: 4450 mm. Width: 1725 mm. Height: 1490 mm. Weight: 1725 kg (gross) 1300 (kerb)

This is the technical profile of the 200 model, according to Toyota, 2010:

- Powertrain: Hybrid electric combustion engine. 98bhp 1.8L petrol engine combined with 80bhp electric motor. Total power of 134bhp.
- Batteries: 202v Nickel-metal hydride (NiMH)
- Architecture: Steel monocoque . Kamm/Koenig-Fachenfeld body style.
- Aerodynamic drag coefficient: 0.25
- Performance: CO2 emissions: 89 g/km. Fuel consumption: 50 mpg Top speed: 112mph (180 km/h).
- Measurements: Length: 4460 mm. Width: 1740 mm. Height: 1530 mm. Weight: 3720 lb.

**The Marketplace** | The most successful hybrid car on the market now is the Toyota Prius, and it has become a status symbol, the car that prominent celebrities choose to appear with at public events. The second generation of the car was responsible for most of its



success, bringing the total sales to an astonishing 1.2 million units (Galvano, 2009). Compared to the market rival produced by Honda at the time, the Civic Hybrid, which had a similar price and performance, the Prius accounted for 53,991 units sold in 2004 against 25,575 for the Honda Civic. Prius's first competitor was the small Honda Insight, that sold 585 units in 2004 and on which production was completed by 2006 (Koener, 2005). Honda and Toyota had different hybrid systems; however, the main difference between the Civic and the Prius was that the Toyota offered the new technology together with a unique body and styling. Honda had tried the same thing with the first Insight, but it was not successful, probably because it was just a two-seater, costing almost the same as the Prius. To challenge the Prius, the second generation of the Insight followed the Toyota design closely, and was cheaper. Robert Cumberford (2009c) stated that 'by adopting a profile almost identical to the second Toyota Prius, Honda established 70-year-old German experimental-sedan ideas as 'green' in no uncertain terms. Apart from the characteristic low-drag profile, this Insight is rather bland and anonymous'. Moreover, to the general public, the Insight, with its weak identity, was inferior to a Prius.



**Figure 176: The new icon: Cameron Diaz, Gwyneth Paltrow and the cartoon dog Brian with their Prius.**

The Prius built its iconic image as the car for environmentalists, or environmental sympathizers, selling beyond its expected market. Chapman (2007) listed more than 30 celebrities who had bought the car <sup>6</sup>: 'the Toyota Prius has become the celebrity car of

---

<sup>6</sup> Some of the celebrities who own the Prius: Jessica Alba, Jennifer Aniston, Chevy Chase, Sheryl Crow, Billy Crystal, Cameron Diaz, Leonardo Di Caprio, Harrison Ford, Tom Hanks, Scarlett Johansson, Angelina Jolie, Jennifer Lopez, Ewan McGregor, Gwyneth Paltrow, Brad Pitt, Natalie Portman, Tim Robbins, Meryl Streep, Charlize Theron and Robin Williams.

choice in Hollywood, on account of its 'green' credentials'. The Prius repeated the success of cars like the Mini and the Beetle, featuring, like them, in cartoons and movies. An episode of the cartoon *South Park* was based around the Prius, criticizing the fact that people might become 'smug' when fighting the 'smog'. In another North American cartoon, *Family Guy*, the intellectual dog, Brian, drives a Prius. These cartoons demonstrate the significance with which the Prius featured in the imagination of the general public.



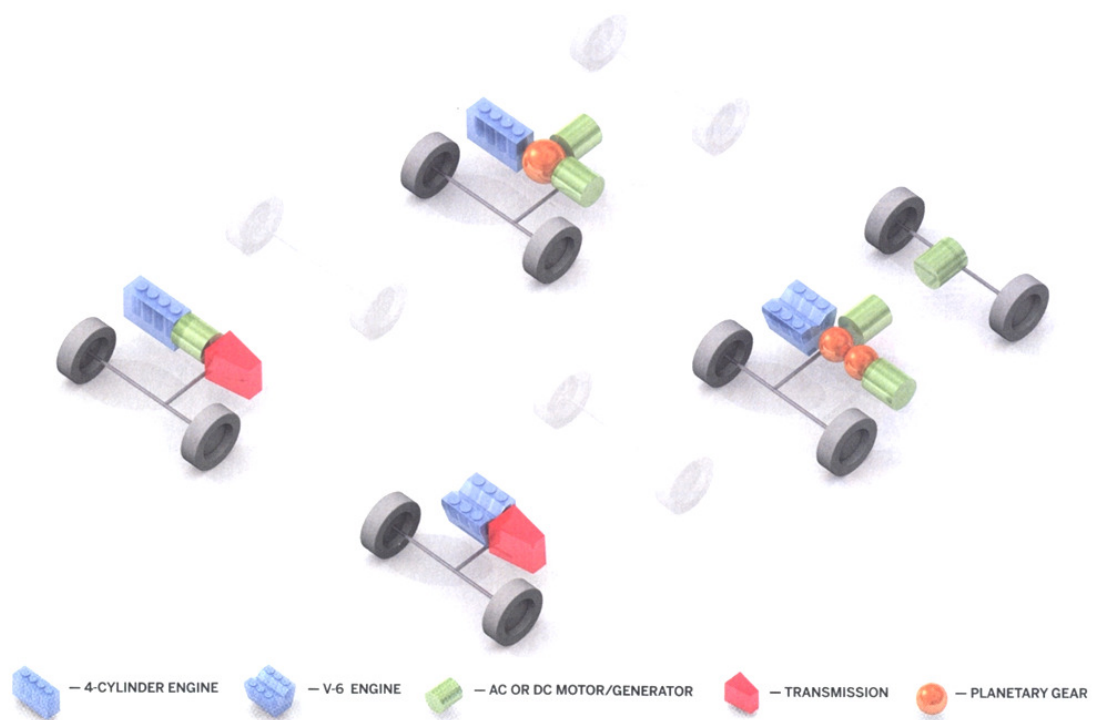
**Figure 177: Competitors of the Toyota Prius: Honda Insight (first and second generation), Honda Civic Hybrid, Chevrolet Volt, Ford Fusion Hybrid, Mercedes-Benz S400 Hybrid.**

Selling beyond its anticipated market, the price of the car became virtually insignificant to conquer its competitors. The Prius stole a share of the market from premium brands like BMW, Porsche and Mercedes-Benz, which had also started planning to launch hybrid cars. In 2009, Mercedes-Benz launched the S400 hybrid, which cost around three times the price of the Prius, and challenged Toyota's flagship luxury hybrid sedan, the Lexus

LS600hL. The very first hybrid by the most traditional car company showed, according to Kacher (2009a), 'a clear indication that its maker is shifting from a strict diesel approach to efficiency and finally acknowledging the worth of hybrids as an essential step on the path to electric propulsion'. In addition, as expected, the Mercedes-Benz model took the technology to a higher level, adopting lithium-ion batteries.

In 2009, Ford unveiled the Fusion Hybrid, a sedan, 25in longer than the Prius, and 60bhp more powerful, and around 10% more expensive. Whilst it might suit well the general expectation of the North American market, it is not a stand-alone hybrid like the Insight and the Prius. The success of these models will again show the relative value of design.

Considering design identity and technology, both strategic in the competition with the Prius, the Chevrolet Volt might be the strongest competitor when it is launched, at the beginning of the decade. The GM model will be a series hybrid, where the ICE only creates power that is then stored in batteries, and the drive is carried out by electric motors. This system is different from the 'Two-Mode', that fits an electric motor inside the transmission. The Two-Mode was developed by a consortium including GM, BMW, Chrysler and Daimler. However, the Mercedes-Benz S400 Hybrid, with an electric motor sandwiched between the transmission and engine, used the same layout as the Honda.



**Figure 178: Different approaches to hybrid powertrain (clockwise from the top): Toyota Synergy Drive, Lexus Hybrid Drive, GM Two-Mode, Honda Integrated Motor Assist.**



Between the different hybrid layouts available in production cars (figure 178), there isn't a solution that can be considered the best. However, some might offer extra benefits, like the possibility of easily transforming the car to a four-wheel drive, seen in the Lexus Hybrid Drive. On the other hand, series systems might simplify the development of pure plug-in EVs. If that hypothesis is true, GM, who started later, could leapfrog over Toyota on the path from hybrid to electric.

### Design analysis |



Figure 179: Design analyses of the second generation Prius.

Toyota (2007) presented the second Prius as 'The beauty of aerodynamics'. Its design is focused on people's perceptions of aerodynamics, which is associated with the shape of hatchbacks and K-cars. The volume will certainly guide the future aesthetic of ecological Toyotas, as the Hybrid X concepts demonstrated. The style tended to be clean and functional in the second model, but edges and carved details were added on the third. The design of the interior was based on simple straight lines and parallel geometry. The dashboard was symmetrical, and did not surround the driver, making a more sociable and spacious interior. The electronic devices and digital screens helped to compose the futuristic aesthetic. The third generation maintained the general layout, but made it more curved around the driver, with a high, centred console. The graphics, with more curves, are more decorative, but the neatness of the overall layout still make it look functional.



Figure 180: The interior of the second generation Prius.



Figure 181: The interior of the third generation Prius.

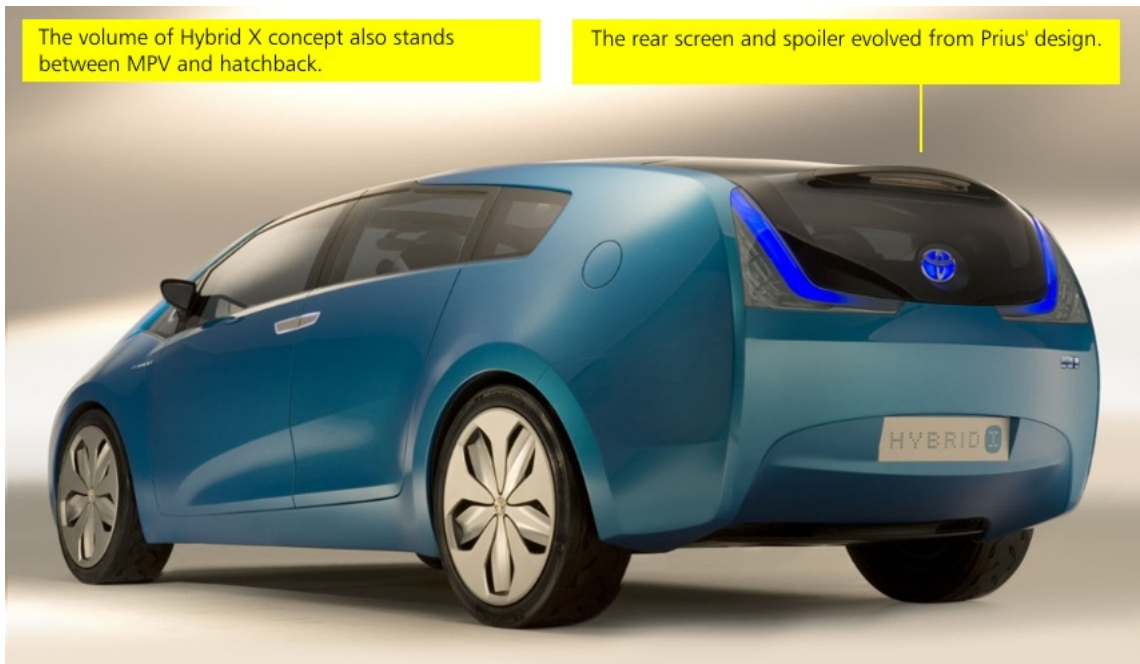


Figure 182: Design analysis of the Toyota Hybrid-X concept.

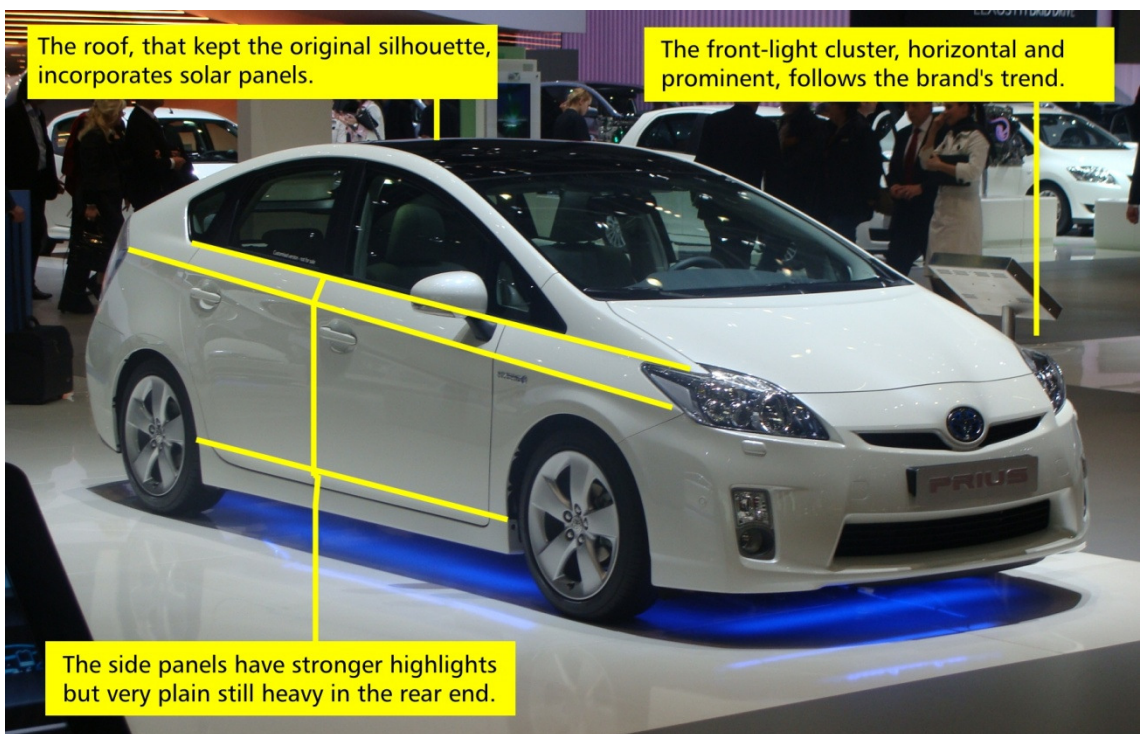


Figure 183: Design analysis of the third generation Prius.

#### 4.3.5. Driving the Prius

To complete the case study I drove the Prius, at the EVER Monaco Conference of Ecological Vehicles, in 2007, 2008 and 2009. I had also the opportunity of driving the rivals from Honda: the Civic in 2007 and the Insight in 2009, and all the Lexus hybrid



models. The Lexus drives smoothly and with the power expected from a premium car. However, this might not be the priority for most Prius owners. The ride provided by the Toyota is comfortable, and expecting more from a car seems an unnecessary waste. Of course, there will always be the value of the space, and a bigger car could offer more, but the expectation would be of having more interior space with less overall size.

The Toyota Synergy Drive makes the transitions between the electric and ICE power happen imperceptibly. When the car goes from stationary to low speeds, with just the electric motor, it accelerates fast, but the perception of this is initially insignificant to drivers used to the noise of the ICE. The visual information about how the engine, motor and battery are working at each moment might impress the driver and remind them that they are driving a hybrid, but is not really necessary, and will soon disappear in future models. The new Insight has a dial that, more usefully, instead shows how ecological one's driving is. The dashboards of all the hybrid cars are excessively populated by electronics, more to create a high-tech image than to inform the driver. However, some of the gadgets of the Prius really impressed me. The back cameras are important equipment for safety. Moreover, the view they afford means that the car parks, without the need to be driven, without the sound of an engine, and really made me believe I was in the car of the future.

#### **4.3.6. Conclusion**

Toyota (2007) stated that with the Prius, 'the dynamic, futuristic styling reflects the car's high-tech imagery'. This was not always taken into account by Honda and Toyota in every hybrid production or concept car. Nevertheless, it was the case with the Prius, and it is the most successful ecological car ever, partly because people can recognise it as one. The Minimalistic styling of the very successful second generation Prius was not too daring, but it suited the expectations and context of the time and raised controversial opinions. Sacha Lakic (2006), the designer of Venturi's new ecological cars, observed that besides proposing an unusual style, Toyota should make it beautiful; in the other side, the designer and design critic Robert Cumberford asserts that the car was beautiful. If the impression of the public could be measured in sales numbers, the design was very successful. It is essential to consider that the judgments of North Americans and Europeans about the Prius are influenced by their traditional tastes and perceptions of car brands. In that context, the Prius has built the Toyota brand more than any other previous model. The car became the most significant new design of the beginning of the 21st



century. The repercussions in the market and product development of other brands are undeniable.

Until now, the body volume, derived from Kamm/Koenig-Fachsenfeld's ideas, seems to be the strongest feature of the Prius, going from one generation to the other, and adopted also by the competitors. Toyota may repeat this aerodynamic solution in future models, and with the evolution of the architecture, reducing the space for engine, motors and batteries, it may also change the focus of car design towards more spacious and pleasant interiors. The 1/X concept (figure 184), unveiled at the 2007 Tokyo Motor Show, confirmed this trend, with a small half litre ICE and hybrid powertrain. To Toyota (*Car Design News*, 2007b) the standard car of the new era 'aims to harmoniously coexist with people and society'.



**Figure 184: Toyota 1/X concept (2007).**

The hybrids function as milestones for sustainable design, and for electric cars. Thus, the styling of ecological cars will probably evolve from the hybrids, especially the ones, like the Prius, that are already searching for it. In history, the Prius follows the Citroen DS, providing a technically revolutionary package to a family car, and, like the Mini, its design makes it classless. When the Myth of Comfort is interpreted in the Age of Sustainability, the status of luxury will be less important than respect for the others and the environment, and therefore in terms of challenging traditional paradigms, the Prius came first.

#### 4.4. Conclusion

In this chapter, three different strategies towards sustainability were observed alongside the study of three important names in the current automobile industry scenario: Smart, Venturi and Prius. The intention was not to compare or provide a scientific analysis of the ecological credentials of the models based on a LCA, which has been the object of research elsewhere in the field of engineering design. The intention was to understand the significance of these cars as references to the evolution of car design. Nevertheless, analysing together the three models in the market, the Smart Fortwo, the Venturi Fetish and the Toyota Prius, it is clear that intentions, their understandings and achievements, are not always synchronized. This becomes a particularly interesting aspect in the light of the acknowledgement that design should be the language to communicate the ideas of a concept.

In terms of the whole design concept, and the ecological benefits it can give, the Smart can be considered the most ecological of the group; however, how much has it been built with the idea of sustainable design? Its 'Swatch style' made it closer to a 'pop-culture' product design, not perceived by the general public as specifically ecological. Clearly, the popular language of eco-design products that was developed in the 1990s significantly referenced natural materials, simplicity in form and function, and the ability to be recycled, that might lead to awkward and incompatible solutions to the language of car design. The Smart took another direction, and, with its relatively expensive price, it turned into a 'fashion-victim' car, driven for many other reasons than ecological concerns. A decade afterwards, Venturi provided an even more expensive and exclusive version of sustainability. The Fétish is well-designed interpretation of the Myth of Speed, but its design language, in spite of nice glimpses of functionalism from Sacha Lakic, is still very conservative. Moreover, while too expensive to become popular and not strong enough to become an icon, the Fétish will not contribute to sustainable design all that Venturi expected from it. On the other hand, the Prius was designed controversially in terms of style and technology, popular and classless. It was the first car to become an icon as a result of its ecological credentials. Its success redirected many companies' research and development towards more sustainable technologies, and gave financial support to it too. None of these cars can be blamed for its failures in developing or applying an aesthetic of sustainable design, while this specific language is at the beginning of its development. With their various weaknesses and strengths, they all collaborated positively to open the door to the Age of Sustainability.

## 5. Project

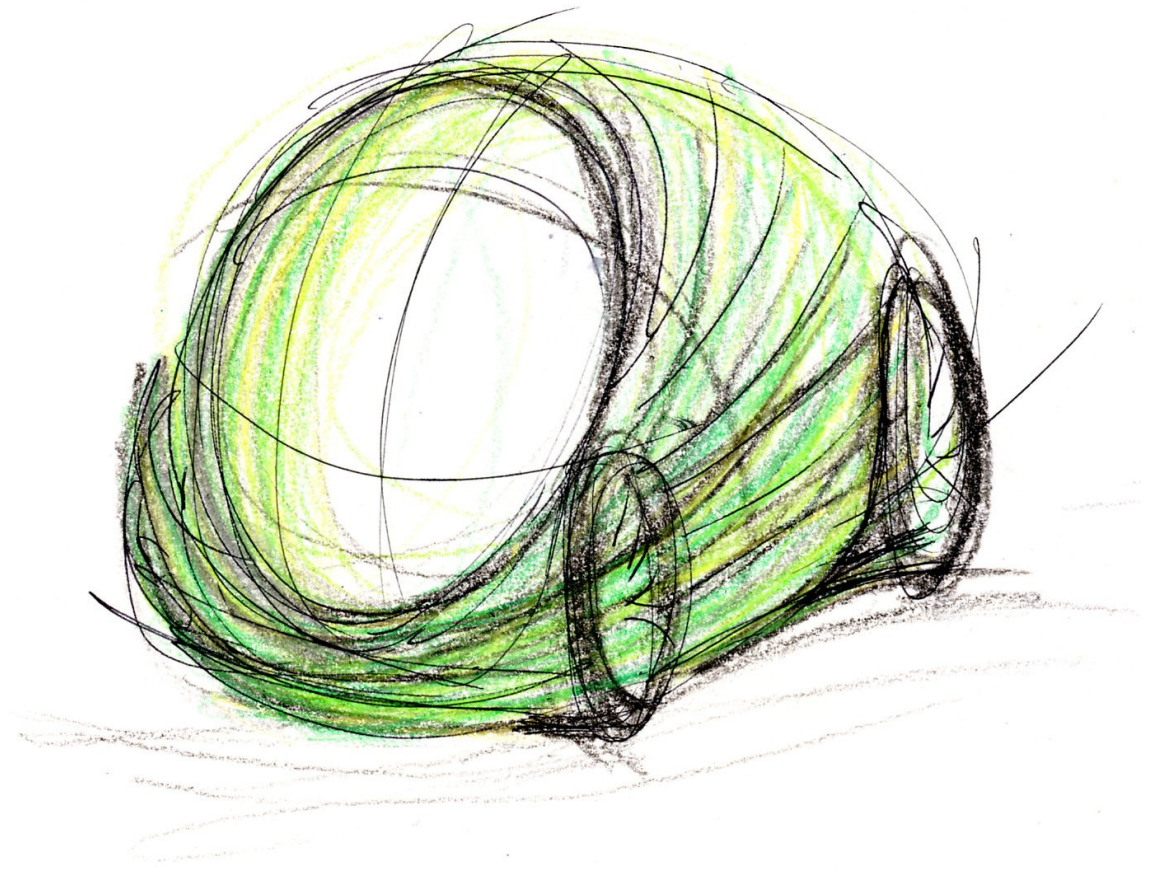


Figure 185: The Seedcar (2007)<sup>7</sup>.

---

<sup>7</sup> During the first two years of the research, I produced a series of sketches to express the aesthetic response to the research being undertaken. The Seedcar (figure 185) is one of these exploratory drawings, created in parallel with the research phase. The drawings had no intention of connecting with any brief, but were used as an exercise to help establish the language that later, influenced the abstract conceptualization phase of the project. The principle behind the Seedcar was to blend the language of the automobile with nature, and to create a hybrid aesthetic. The Seedcar became a specific reference for the research, because it expresses optimism about the relationship between the automobile and sustainability.

**Introduction |** In this chapter, the entire project phase of the research is presented. The chapter is structured in the light of the design model presented in the Methodology. The focus is the two initial phases of Archer's three phase design model (Cross, 1989).

The analytical phase, initiated in the survey, is completed in the first sections of the chapter and presented together with considerations about the approach of the project. A reflective observation of the myths of Freedom, Speed and Comfort is developed to define the project brief, investigating a new model of society, with ethical habits of consumption and behaviour.

The creative phase was developed through three different project themes, one for each of the Three Myths: Frisbee and Freedom, Fluid and Speed, Core and Comfort. All of them were developed through a process, based on Gray and Malins (2004), that included: reflective observation, conceptualization and experimentation. The last phase encompassed the collaboration of the MA students of the RCA Vehicle Design department.

The last sections of the chapter show the evaluation process that was carried out in the light of the findings of the literature review and with the participation and critical analyses of designers from the industry, and the final conclusions of the project.

**Paradigm Shift** | After the reflective observation carried out in the literature review and case studies, the conclusion is that there is both the necessity and the opportunity to a paradigm shift in car design. The research shows evidence that the current age of car design is coming to an end, and, due to the extensive changes in the context, traditional technology and aesthetics are becoming inappropriate. The aesthetics of car design, the main focus of this research, has presented a particular problem in attempting to break from its 'cage of introversion', while it is informed by conventional notions of beauty and taste. A revolution in design is therefore necessary, in order to establish new values, practices and understandings. In proposing a paradigm shift project, this research aims to reframe aesthetics and anticipate the nature of the design language of the automobile in the Age of Sustainability.

Today, the automobile is locked into its own paradigms. This situation also represents the stagnation in creativity that feeds the paradox of current automobile aesthetics. According to Walker (2006), the aesthetic is a representation of our beliefs and ourselves. A paradigm shift aspires to change the image of the car, turning it into a reference to sustainability.

The outcomes of this project may help automobile manufacturers to develop new concepts and future sustainable cars. The industry is also urging change in current models of mobility, towards more sustainable ones. New combined modes of transport, enhanced public transport, alternative vehicle types, and new concepts of ownership and use are all necessary, and applicable differently in each particular case. Nevertheless, the private car will need to be included in this process. Aiming to change the way we drive, look at, feel, and understand cars, the project shows a series of provocative designs to question the current paradigms, and offer an alternative route for car design, towards sustainability.

The research shows that more sustainable technologies are in fact being investigated; however, it is also understood that sustainability is a kind of utopia, in the sense that perfection cannot be achieved. This research has therefore adopted a myth-based approach to sustainability, suggested by Walker (2006), follows design guidelines according to Vezzoli (2000) and Fuad-Luke (2002), and has set ideal objectives for the project, instead of fixed technologies. Some assumptions, nevertheless, can be made and accepted as part of a probable brief for sustainable cars of the future.

**Briefing for the sustainable car** | The brief intends to develop the project by taking into account some of the advances in technology that already can be seen, or will soon be incorporated into new vehicles; in addition, the brief is open to provocative designs that might stimulate research in different fields. The project is not limited by a target time or by available technologies, but focused on creating references to the development of design. In doing so, the aesthetic intentions of the design will help to direct the development of the technology towards sustainability.

Following the principle of the project, the brief assumes that the sustainable automobile will be driven by electric motor - the most efficient and clean during use - and anticipates the development of battery technology, that will eventually provide smaller, lighter and more efficient packages. It is also understood that electric energy, used to power vehicles and everything else in the urban environment, has to be provided from clean and renewable resources. The adoption of electric vehicles, with energy provided from solar- and wind-power stations, can minimize the impact on the environment, and lower CO<sub>2</sub> emissions to zero. The brief assumes that this is a condition of any project in the Age of Sustainability.

The use of the electric powertrain, combined with information technology, can not only provide new packages, with more freedom for the development of automobile interiors, but can also change completely the way we use and drive cars. With more efficient motors and batteries, the space needed for the powertrain will be relatively much smaller, and the possibilities for different layouts will increase, making the sustainable car more flexible and adaptable for specific users. Thus the brief proposes that the sustainable car will not limit or deprive the user of their particular tastes and requirements, but will open up more solutions, taking account of this diversity and directing it towards a sustainable practice.

The brief suggests the use of renewable, recyclable materials that could also respond to new functional and aesthetic requirements. In addition, the use of materials has to be sensitive to the ecological context, responding to bioregion and local culture. Moreover, the issues listed by Papanek (1972), Birkeland (2002), Fuad-Luke (2002), Vezzolli and Manzini (2002), and others, discussed in the literature review section on sustainable design, must be observed. Nevertheless, it is important to emphasize that the objective of the project is not to resolve the whole question of the existence of the automobile, but to reframe it with more sustainable principles, investigating a future aesthetic.

**Art as research** | Freedom of creativity is essential to this exercise; thus the project focused on interpreting the changes in context and technology through a process of 'art/design as research'. This approach, suggested by Sir Christopher Frayling (2006), Gray (2006) and Archer (1996), also matches ideally the profile of the Royal College of Art, where the research has been undertaken. Moreover, within academia - separated as it is from the pressures and pace of private sector practice - it is possible to reframe design by adopting a more critical and artistic approach.

Projects undertaken with this approach might also stimulate the development of sustainable technologies, and inspire designers and engineers to create innovative and unexpected solutions. This was certainly the case with the concept designed by Ross Lovegrove (figure 186) referred to earlier in this project. The Welsh designer developed a vehicle concept in association with Sharp and Swarovski, where he explored the aerodynamic shape of a solar car through an artistic approach. The sculptural form also incorporated the idea of clean mobility, with zero-emission photovoltaic panels, which, however, are not yet reality. Nevertheless, the 2006 Crystal Aerospace is a concept that meets our most inspiring aspirations towards beauty and sustainability. It offers a strong reference point for the new emerging aesthetics.



**Figure 186: Crystal Aerospace concept (2006).**

According to Fagnola (2008), Lovegrove was inspired in the development of this project by the forms of solar cars that compete in the World Solar Challenge and other similar events in Australia. His interest is the conjunction of nature and technology, reaching excellence in performance with a real sense of a sustainable future. The project aims to change the focus of collective ambitions, and, as a result, constitutes the creation of a new aesthetic reference point.



The shape of the car is based on a combination of the curves existing in nature and the strength of the man-made industrial geometry of the square. Lovegrove proposes the demonstrating of new and sustainable technology as a major element of the design; the photovoltaic cells and crystals will cover the body of future automobiles, their beauty inheriting the value of ecological principles. Although the car does not function as a transportation device for people or freight, it delivers its message, creates a language. Its renunciation of functionality makes it closer to both a work of art, and the dream of clean mobility. Lovegrove located our aspirations at the point of perfection, and his design epitomizes the mythical sustainable car.

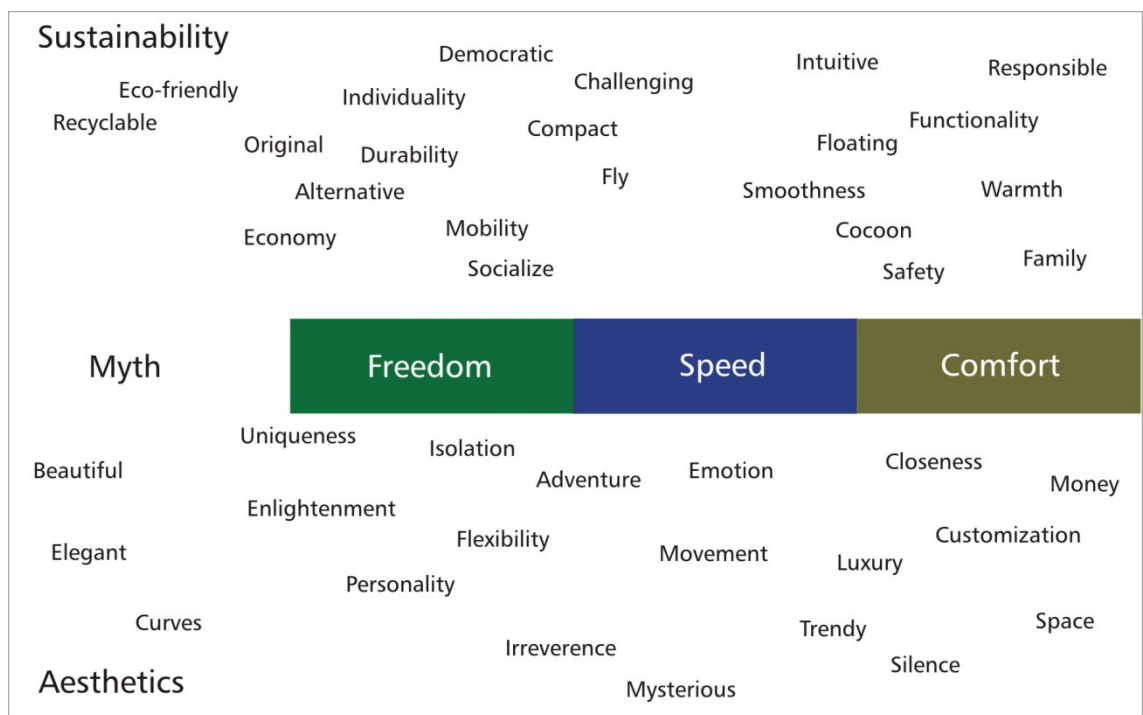
The Crystal Aerospace was the only non-Italian design included in the retrospective exhibition *Dream - l'auto del futuro dal 1950*, held in Turin in 2008. In the exhibition catalogue, Fagnola (2008) recalls that the aspiration for auto-mobility has existed for a long time in many different cultures and was inspired by dreams, fiction or science, from Leonardo da Vinci to Jules Verne. Nowadays it is essential to apply the same creativity to the search for more sustainable means of transport, to keep this dream alive. The brief intends to create examples of paradigm-shift projects that explore future solutions for the sustainable automobile through an innovative and inspiring design process located in the frontier between fiction and art. Cesare Pavese stated that fantasy is not the opposite of intelligence. It is, instead, intelligence applied through the use of symbolism and analogy, and is indispensable to design practice (Lorenza Pininfarina, 2008).

The brief suggests using the imagination to open up new perspectives, and anticipates the creation of an object that is closer to art, that might enhance the aesthetic experience. Thus the aesthetics will support, communicate and guide the intellectual investigation of sustainability. As Goldman (2001) states, 'while the purpose of art may not be pleasure in the narrow sense, it is the enjoyment, refreshment and enlightenment that such a full experience provides. Great art challenges our intellects as well as our perceptual and emotional capacities.'

This process was the start of a phase of abstract conceptualization, in which, through drawings and modelling, three initial concepts were created as aesthetic references to consolidate the objectives of the brief. At this point, the brief is divided into three pathways, for the purpose of investigating different aspects in each one. The three pathways are related to the three myths that sustain people's connection with the automobile, the myths of Freedom, Speed and Comfort.

**Defining the three myths |** The three myths were defined during the historical summary in this research. They were consistently viewed as either objectives, design characteristics or inspirational meanings. The Myth of Speed, and its relationship with the aesthetics of the Industrial Age, has been studied most often, especially when the fantasy created by design went on to inspire Futurist artists and originated *La Bellezza della Velocità*.

Kleber Puchaski's research (2009), *Feel the Future - Perceptions of branding and design towards product development in the motor industry*, also identified, through the results of workshops, the importance of the three myths. In Puchaski's research, the participants of a workshop chose five words that could be described as drivers for the future. These words would reflect the participants' aspirations and dreams relating to the issues that might affect our interaction with the 'object car' in the future. The words referred to most often were: comfort (11), safety (5), speed (5), freedom (3), compact (3), space (3). The results are mapped in figure 187, showing their relationship to the three myths.



**Figure 187: Map developed from the results of Puchaski's research, *Feel the Future* (2009).**

Using the myths as references to study the evolution of automobile aesthetics, it was possible to link contemporary designs to their original purposes, and most importantly it was possible to isolate three distinct drivers of the design language that are associated with unique aesthetic experiences. Once isolated, the meanings of the myths were described, their epitomes were located in a historical context, and their meanings were reinterpreted in the context of the Age of Sustainability.

These meanings and their reinterpretation in the context of sustainability were focus of brainstorming, especially during the third year of the research, with collaboration of RCA colleagues. In the brainstorming, our relationship with the automobile was discussed, observing its cultural reflection in films, literature and the imagination, and also the relationship between object and context, user and needs. The aim of the brainstorming was to understand the nature of pure experiences and pure responses to needs in the context of the car, and to transform the scope of *design for user needs* into *design for user aspirations*. This would thus enhance the intention of the brief to work towards aesthetically-pleasing solutions.

The brainstorming showed that, traditionally, the Myth of Freedom was associated with the following notions: independence, auto-mobility, time availability, unlimited choice, lack of restrictions, and movement. The Myth of Speed was associated with movement, time-saving, power, velocity, experience, hallucination, and control. The Myth of Comfort was associated with control, time convenience, safety, shelter, intimacy, relaxation, space and knowledge.

The epitomes were observed in the second part of the literature review. The epitome symbolising the Myth of Freedom in the Age of Pioneers, is the Ford Model-T, and in the Evolutionary Age, the Volkswagen Golf. The epitome of the Myth of Speed in the Age of Pioneers is the Bugatti Type 35, and in the Evolutionary Age, the Ferrari F40. In the Age of Pioneers, the epitome of the Myth of Comfort is the Rolls-Royce Silver Ghost and in the Evolutionary Age, the Citroen DS. The Smart Fortwo, the Venturi Fétish and the Toyota Prius stand out in the transition towards sustainability as icons of Freedom, Speed and Comfort, respectively.

All this information was incorporated into the first part of the Project Chart (see figure 188). The reinterpretation of the myths in the context of sustainability, images of design references that have investigated similar questions, inspirational images, and the project challenges discussed with the research supervisor were added to the second part of the Project Chart (see figure 188). The reinterpretation of the three myths in the context of sustainability brought new aspects to their meanings, some of which were substitutes and some additions. The Myth of Freedom was associated with the following: freedom from material possessions, freedom from ownership, and respect for difference, universality and uniqueness. The Myth of Speed was associated with enhanced sensations, smoothness, connections, blending in with the environment and the spontaneous movement of nature.

The Myth of Comfort was associated with interaction, information, universal accessibility, time to oneself, feeling natural materials, sharing, and flexible space.

This reinterpretation took into account not only principles of sustainability, but also the very significant changes in society that have occurred as a consequence of the digital revolution in communication and information technology. This revolution and the shift to sustainability are inseparable; however, while the first may be a reality, the focus is maintained on the second because it is an essential condition for our common future.

Myth	Freedom	Speed	Comfort
Meaning	Time availability Independence Auto-mobility Unlimited choices	Time saving Velocity Power Excitement	Experience Hallucination Control Relaxing Knowledge
Epitomes of pioneers age			
Epitomes of evolutionary age			
Epitomes towards sustainability			
<b>Context of the Age of Sustainability</b>			
Reinterpretation	Freedom from material possession Universality Freedom from ownership Respect differences	Enhance sensations Uniqueness Smoothness Spontaneous movement of nature	Interaction Blend with environment More connections Universal Accessibility
Project challenges	Feeling of the privacy in a public context Always there for you Respect public spaces	Dynamism of nature Translate the beauty of movement Indulgence	Feeling natural materials Driver-less with safety feeling New family culture Democracy
Project references	Feasible 	Power without fear 	Driver-less with control 
Inspirations			

Figure 188: Project Chart - first part.

**Creating the aesthetic experience** | After this exercise, using the process of art as research, the myths were investigated separately. To create an aesthetic experience it was necessary to move from theory to experimental objects. In the initial stage I developed three concepts, entitled Frisbee, Fluid and Core. Later, these concepts helped to define the specific brief for the three pathways, and the active experimentation stage was undertaken with the participation of MA students from the Royal College of Art's Vehicle Design Department. For this stage the Project Chart was an important visual reference, which helped to communicate the research to the students. On 5 October 2009 the students were introduced to the research in a lecture, and they received the project brief. The brief suggested the following:

Cars used to be literally "horseless carriages". Then they morphed into the modern car format with a single integrated body soon after the Second World War. But for over six decades there has been no new paradigm for car design. Now, with electric power and advanced information systems, there is arguably an opportunity to create a new car design paradigm. In the beginning, the internal combustion engine automobile broke with the language of horse-drawn carriages. Now, the ecological car has to break with that of the traditional automobile.

The challenge is to develop paradigm-shift designs that explore future solutions for the sustainable automobile through innovative and inspiring concepts developed in the frontier between fiction and art. The given concepts are new interpretations of the Myths of Freedom, Speed and Comfort, which will be developed inside the department pathways.

The reinterpretation of the three Myths aims to renew the aesthetics of the automobile, ending the regurgitation of past stylistic conventions based on unsustainable practices, and giving the dream of auto-mobility a sustainable future.

The brief is to research and create paradigm-shift designs that support three core concepts of the related ongoing research. These must eschew conventional automotive design idioms and introduce powerful non-automotive aesthetics.

The following sections demonstrate the three different pathways, and the designs which were developed in search of an aesthetic paradigm shift.

## 5.1. Frisbee and Freedom



**Figure 189:** Scene from Ridley Scott's film *Thelma & Louise* (1991).

The concept of auto-mobility is intrinsically connected to freedom, to the ability to move easily, with independence and without limits. When the industry began to produce substitutes for horse-drawn carriages, the automobile became people's favourite vehicle for exploring their territory, travelling, or simply for commuting with autonomy.

When Henry Ford popularized the automobile, freedom of movement gained an unprecedented scale. However, the fantasy of escape – as explored in Ridley Scott's film *Thelma & Louise* (figure 189) - was progressively replaced by the reality of the autonomous commute. Nevertheless, behind the tool there is always the myth. After the Model-T came the Beetle, the 2CV, the Mini and many other cars that provided freedom of movement to society. The popularity of the automobile also meant that more people were sharing the benefits of independence. Nowadays, with an increasing proportion of the global population living in cities, the concept of freedom is more a counterpoint to collective movement, represented by public transport, which is often perceived as less flexible and impersonal.

In a critical analysis, the use of the automobile in the city results in the appropriation of public space for private use, creating inequality, and it is contradictory to the concept of sustainability. This project, however, does not argue against the private automobile, but questions its established concept and searches for a solution which provides the same, or better, benefits in a sustainable fashion. Thus Project Frisbee explores a new meaning for the Myth of Freedom, through the creation of designs that refer to the Myth in the context of sustainability.

### 5.1.1. Freedom in the Age of Sustainability

The conflict between private and public - urban space and the car - is one of the most important questions to be addressed in the project. With reference to the equation formulated by Ekins (1992),  $I=PCT$ , in order that technology (T) may evolve towards an ideal sustainable goal, the population (P) will continue to grow, and to reduce the impact (I), it is necessary to change our consumption habits (C). Furthermore, land is a limited resource, especially in cities, and private use of it must not cause inequality.

Nowadays, some of the solutions adopted to control the use of the private car in big cities, apart from being of benefit to the environment by reducing pollution and traffic, are discriminatory, and are not acceptable according to the principles of sustainability that assert that everyone (taking into consideration future generations) has the same right to global space and resources (WCED, 1987). In São Paulo, where one day a week private cars cannot be used in the rush hour, wealthy families ended up buying an extra car for this day, and with the growth in the numbers of cars on the roads, the police are no longer effective. The Congestion Charge, implemented in London, UK, affects those who have higher disposable incomes less than those on lower incomes. However, everyone suffers from the lack of parking spaces, and car use has become impractical.

Freedom from ownership appears to be a solution, and car-sharing systems will tend to be more popular in the future. In terms of the Myth, it takes Freedom to an advanced level. Thus the project will not consider the traditional paradigm of the private car; instead, focusing on the user, not the object, the project will respond to the needs of the private user. Ownership does not guarantee the results expected from the car, and in addition stimulates a system of consumption that impacts heavily on the environment and does not support the economy.

To reduce the impact on the environment, the dematerialization of the economy, proposed by Manzini (2006), also enhances the Myth of Freedom and creates virtual ownership. The freedom from material possessions can provide the same or better results, without unnecessary use of resources.

In a context where the user demands solutions, instead of physical products, and the solutions do not demand materiality, this kind of 'Freedom' can be enjoyed by everyone, and the solution must be ubiquitous. Moreover, this universality can be achieved with respect for differences. Therefore the systems have to be more flexible.



We are moving from a time when people used to relate to a specific design, like the Mini, to a point when design will relate to one person. In this transitional period, there is great diversity in design solutions, but people fail to identify them. The future will be based around locally-developed design. Freedom is associated with individuality and personality, and uniqueness must be respected in the Age of Sustainability.

### 5.1.2. Project challenges

Once we move from the private car to car-sharing systems, there are a number of extra challenges that the design must take into account, in a sustainable way, to keep or improve the benefits people are used to getting from the car.

The owner of a car has the benefit of having the vehicle available for his/her use whenever it is needed. Thus, a car-sharing system will only be a solution if the vehicle will always be available for the user. It is acknowledged that until a sharing system is widely available, the transitional period might represent some difficulties for early users. Nevertheless, the transition to sustainability has to be made, and, according to Manzini and Vezzoli (2002), being progressive, the transition will impact less on society and the environment.

Car-sharing systems have been investigated for a long time. In an academic context, Ari Antonio da Rocha's doctoral thesis (1973) covered the subject of the car in the city and proposed a sharing system, with a car based on his 1965 Fissore Aruanda concept. In industry, Giorgetto Giugiaro proposed a car-sharing system in 1992 with the Biga concept. In addition to the respect for the integrity of public spaces offered by these concepts, the project must explore their aesthetic relationship to the landscape.

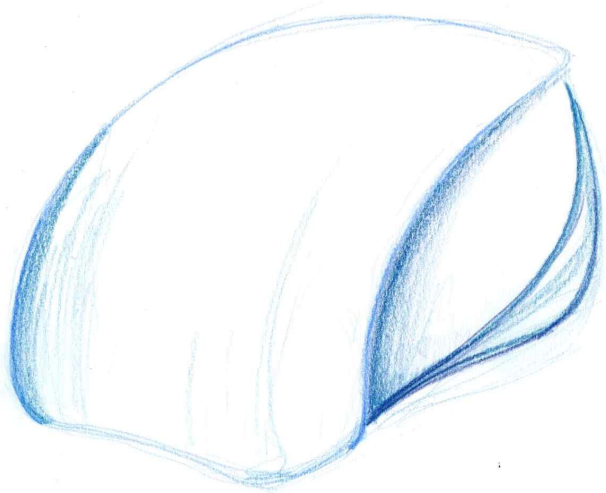
The acceptance of a sharing system for urban cars will only be achieved if the system is practical, viable, realistic and feasible. Nevertheless, perfection in relation to function is not enough to improve the quality of life in the city. The automobile always offers a level of privacy that public transport cannot. The need for privacy in a public context must be respected. The project assumes that there will always be space for different modes of transport, each with their own particular characteristics. All of them must be developed in order to reach the objectives of sustainability, and they must be available and accessible to everyone. The new city car must be ubiquitous through all classes, respect individual taste and personality, and express respect for both the environment and society.

### 5.1.3. Conceptualization phase

The conceptualization of Project Frisbee was done on two fronts, both at the same time. On one side, the response to the initial questions was researched to define a design brief. On the other side, the aesthetic aspect was investigated through sketching and modelling.

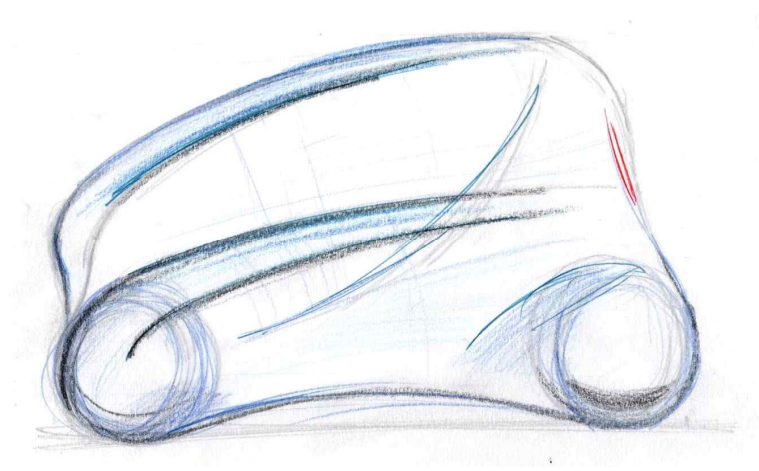
The essence of the Frisbee concept was defined early on in the conceptualization stage. The Frisbee was defined as a vehicle and a system, designed for the purpose of creating a feasible car-sharing system. Thus the car should go from user to user, within the city, and spend less time parked and more in motion. The name of the concept was taken from the sport in which the frisbee disc goes from hand to hand, in a collective exercise, with enjoyment, silently and smoothly. In addition, the vehicle changes its appearance when the user changes, in order to respect the taste and personality of the user.

The initial concept, then, was a car that morphs following the configuration chosen by its users. Therefore the design is based on the car at two different points in time. The first is the Blank Car, when the car is stationary, parked in the street before or after use. The second is the Configured Car, that can assume a range of different shapes and colours, according to the selection made by the user.



**Figure 190: Sketch of the Frisbee Blank Car (2009).**

The first investigation (figure 190) of the shape intended to find a minimalist and fairly automotive form. The design evolved into a Clean Shape, based to an extent on organic forms. Moreover, the intention of the design is also to create an identity for the Blank Car.



**Figure 191: Sketch of the Frisbee Blank Car (2009).**

The design language of the Blank Car (figures 191-192) searches for both smoothness and an ability to blend in with the landscape; hence the Frisbee can adopt particular colours to harmonize with the surrounding environment in which it is parked. The Frisbee Blank Car can become a ubiquitous element in the cityscape; however, the system can be configured differently according to the neighbourhood and local regulations. Thus the automobile can be included in the design and planning of the city in the same way as street furniture. Thus the Frisbee can morph through three stages: first, the Blank Car blended into cityscape 1; second, the Configured Car following the options of user 1; third, the Blank Car blended into cityscape.



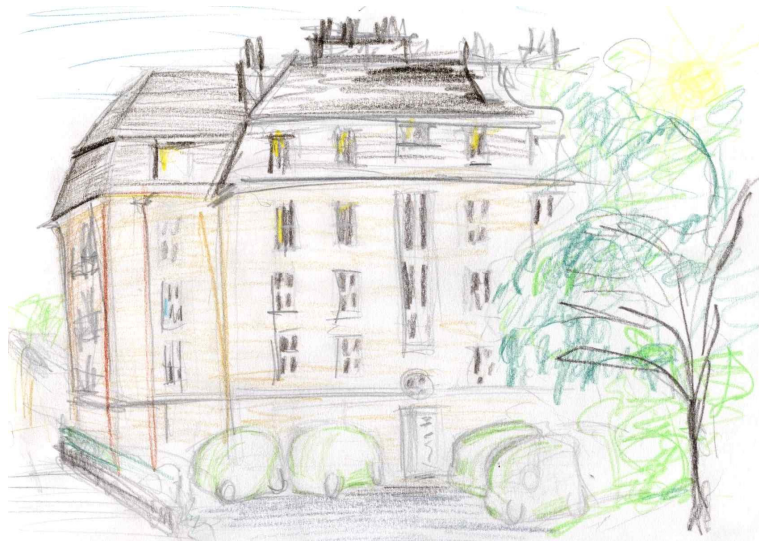
**Figure 192: Sketch of Frisbee Blank Cars parked in a street (2009).**

When the Frisbee detects the presence of a user searching for a car, it turns itself into a Configured Car (figure 193). At this moment, the car adopts the user's chosen shape and colour and downloads the information the user wants inside his/her Frisbee - music, maps,

phone numbers. Then the user recognizes his/her car and can use it as he wishes, leaving it later to go back to Blank again (figure 194).



**Figure 193: Sketch of a Frisbee standing out in the row to be used (2009).**



**Figure 194: Sketch of the impact of Frisbees on the city landscape (2009).**

The extent to which the Frisbee can morph is questionable. The expectation is that as technology evolves, more morphing will be possible. The body must be made with intelligent surfaces, controlled by information technology. Nevertheless, the principle assumes that the Frisbee will be more flexible than the traditional car, so the selection of materials for the design will be different. The Frisbee body should incorporate more textiles, natural fibres and bio-resins, in order to be lighter and use renewable resources.

The modelling phase followed this principle. Once the model (figures 195-197) was developed with the intention of provoking an aesthetic experience, its functionality was not related to informing a design by displaying a miniature of itself, but to expressing the aesthetic properties of an unusual material to be experienced by viewer.



Figure 195: Bio-resin model of the Frisbee Blank Car (2009).

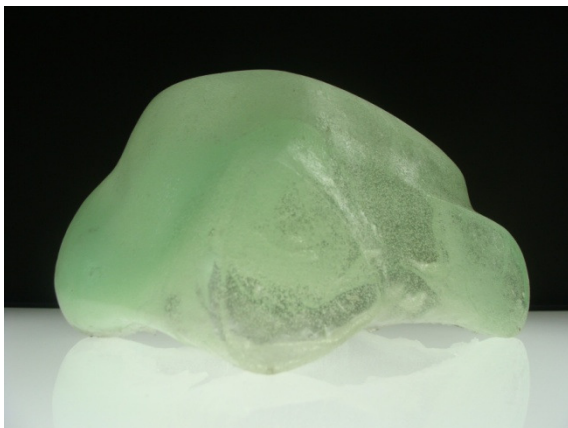


Figure 196: Bio-resin model of the Frisbee Blank Car (2009).



Figure 197: Bio-resin model of the Frisbee Blank Car (2009).



In this case, the viewers were the MA students in the Vehicle Design Department, who would receive the brief and design many different versions of the Frisbee Configured Cars. The crude and abstract language of the model reflected the intention to stimulate the designers to take an experimental path, free from the constraints of traditional automotive design language. The work they developed is shown in the next section.

#### 5.1.4. Experimentation phase

The experimentation phase was done with the collaboration of MA students in the Vehicle Design Department of the Royal College of Art. Five first-year students and two second-year students participated in the group working on the Paradigm Shift - Frisbee Project. They were divided into three groups, as mentioned before, in order to identify a typical user in three locations in London. They then designed a Frisbee Configured Car for this specific user, for an undefined time in the future, but in the context of the Age of Sustainability. The locations were:

- Hoxton Square: a garden square in the borough of Hackney, in the city's East End. The place is known for being trendy, a focus for the art and media scene. The famous White Cube art gallery is located in Hoxton Square, along with the restaurants and bars that make up the area's vibrant night life.
- BedZED (Beddington Zero (fossil) Energy Development): an eco-friendly housing development in Hackbridge, in the borough of Sutton. This development was designed following ecological principles and is aesthetically and architecturally very different from the rest of London.
- The Boltons: an area in Chelsea, featuring traditional Victorian houses, home to wealthy families who can afford premium cars. The area has large gardens and big trees, and in the centre is a big square with a church.



Figure 198: Hoxton Square, BedZED and The Boltons.

**Final brief** | The brief to the Frisbee Project added to the general brief showed before:

A blank screen of a car, the Frisbee is the ultimate concept for a car-sharing vehicle which morphs into a form dedicated to the individual user when they connect to it, and can be kept as their digital car in a virtual form.

Conduct research into car users and their environment in a specific London location for a period of one day, using non-participant observation. From this, define a particular archetypal user for whom your small (2.5m long) urban car must be very specifically designed. Your design will then feature as one of many forms that the Frisbee car may take.

The designs developed by the students are shown and described in the following section.

**Hoxton Frisbee by Fernando Ocana Espinosa** | Figure 199 | Fernando Ocana Espinosa (2009) focused on understanding the user's personality and on supplying the concept with a 'new means of expression'. He adopted 'amorphous surfaces', product of a mesh of micro-connections that respond to electronic inputs. The surfaces are made of semi-translucent soft material. Fernando proposed Hoxton's Frisbee Blank Car as an experience of detachment. After using the car, it turns into a shape that resembles smashed paper. The shape regains a vehicular form when in use, and creates a metaphor for a recycling process.

**Hoxton Frisbee by Ido Baruchin** | Figure 200 | Ido Baruchin designed an autonomous vehicle that could also generate energy when parked. In addition to the Frisbee concept, his vehicle transforms itself into street furniture when parked in the Hoxton Square area. According to Ido (2009) the sense of community of Hoxton's users will extend the sharing system to the journeys, too. Thus, the cars is also designed to be shared by two or three passengers, becoming a small public vehicle. Flexibility is again achieved by intelligent surfaces: in this case, the external walls are in bio-elastic panels.

**BedZed Frisbee by Juha-Pekka Rautio** | Figure 201 | Juha-Pekka Rautio's design for the Frisbee emerged from the connection to nature expected from a resident of BedZED. His Frisbee expresses its changes through a movement inspired by a flower blooming. He proposed a biomorphic shape that could also imitate this behaviour seen in nature.



**BedZed Frisbee by David Eburah** | Figure 202 | David Eburah's design for the BedZED Frisbee is also focused on the connection to elements in nature. David's design explores the use of an artificially-grown spider silk that has been developed by American and British scientists<sup>8</sup> using a spider silk gene. David's Frisbee collects information from the road and the environment, creating a particular story for each journey and each user. As the wheels rotate, they gradually spin the web, changing the aesthetic of the car. The alloy 'shape memory' properties of the silk takes the car back to blank after use.

**BedZed Frisbee by Heikky Juvonen** | Figure 200 | Heikky Juvonen's design for the BedZED Frisbee is based on a 'skeleton and skin' architecture, inspired by the dynamics of the human lungs, and aims to create an ultra-light vehicle. The user can choose different expressions, and also determine the dimensions of the vehicle through the variation on the air pressure in the skin layer, and through the movement of the skeleton itself

**The Boltons Frisbee by Young-Seong Kim** | Figure 201 | The design of The Boltons Frisbee by Young-Seong Kim reflects the more traditional profile expected of the inhabitant of this area. As a consequence, it is the only project in which the design is associated with a traditional car manufacturer. Kim's (2009) design is based on a 'cradle' architecture that protects the user, in the same way as Smart's Tridion Cell. The different personalities of the Frisbee are expressed by moving fenders and lateral panels, and screen projections of graphics and colours.

**Other results** | Two students failed to answer to the brief.

---

<sup>8</sup> David Eburah (2008) supported his concept with Roger Highfield's article in the *Proceedings of the National Academy of Sciences*, DOI:10.1073/pnas.0601096103.



Figure 199: Presentation board for Hoxton Frisbee by Fernando Ocana Espinosa (2009).

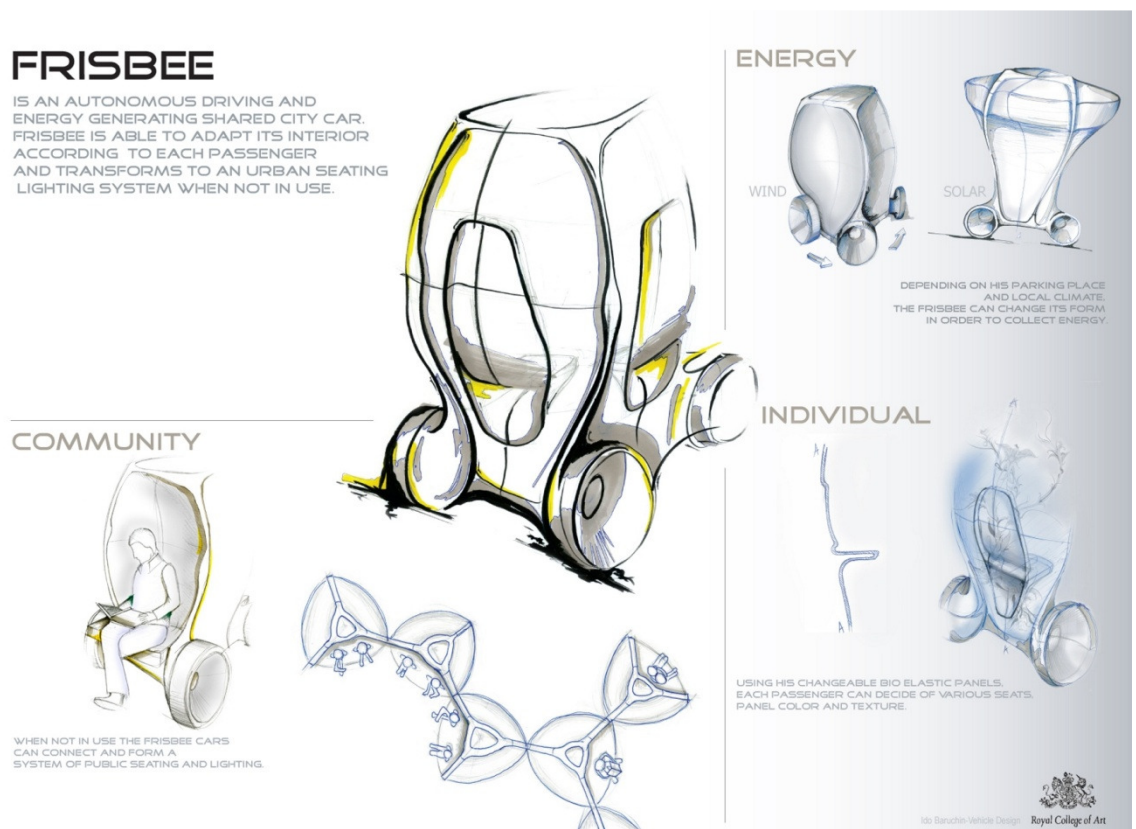


Figure 200: Presentation board of Hoxton Frisbee by Ido Baruchin (2009).



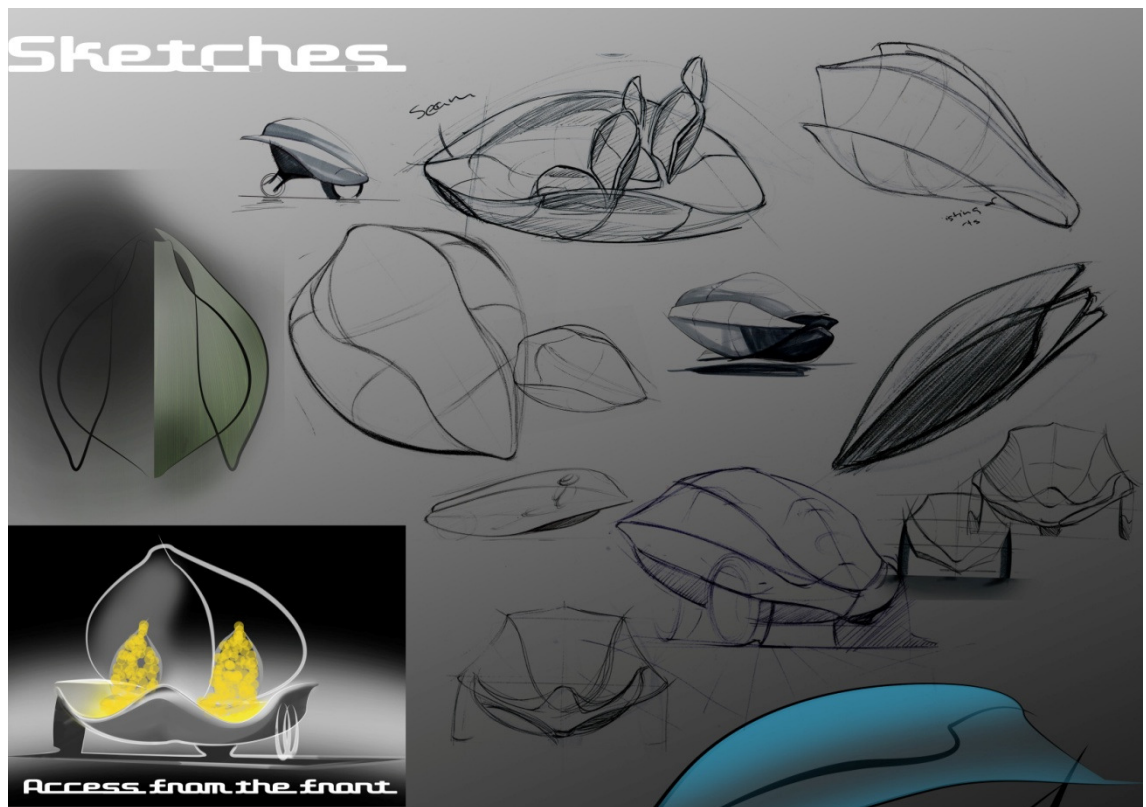


Figure 201: Presentation board for BedZED's Frisbee by Juha-Pekka Rautio (2009).

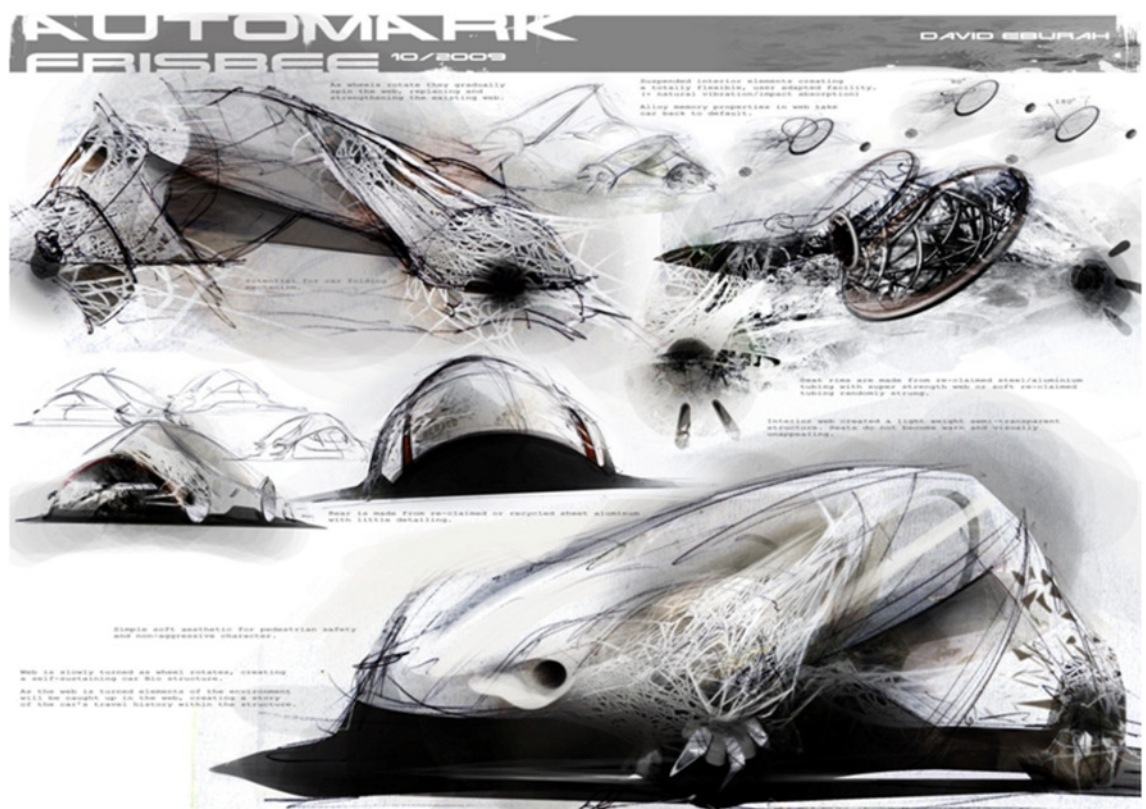


Figure 202: Presentation board for BedZED Frisbee by David Eburah (2009).

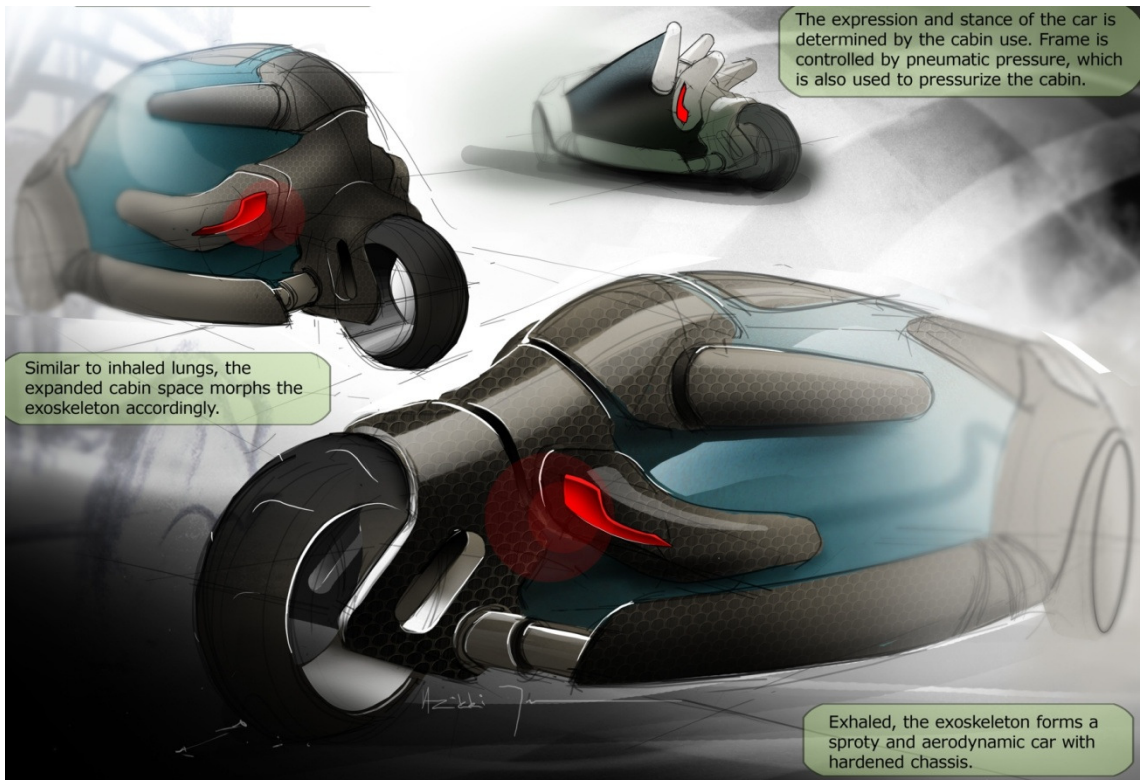


Figure 203: Presentation board of BedZED Frisbee by Heikky Juvonen (2009).

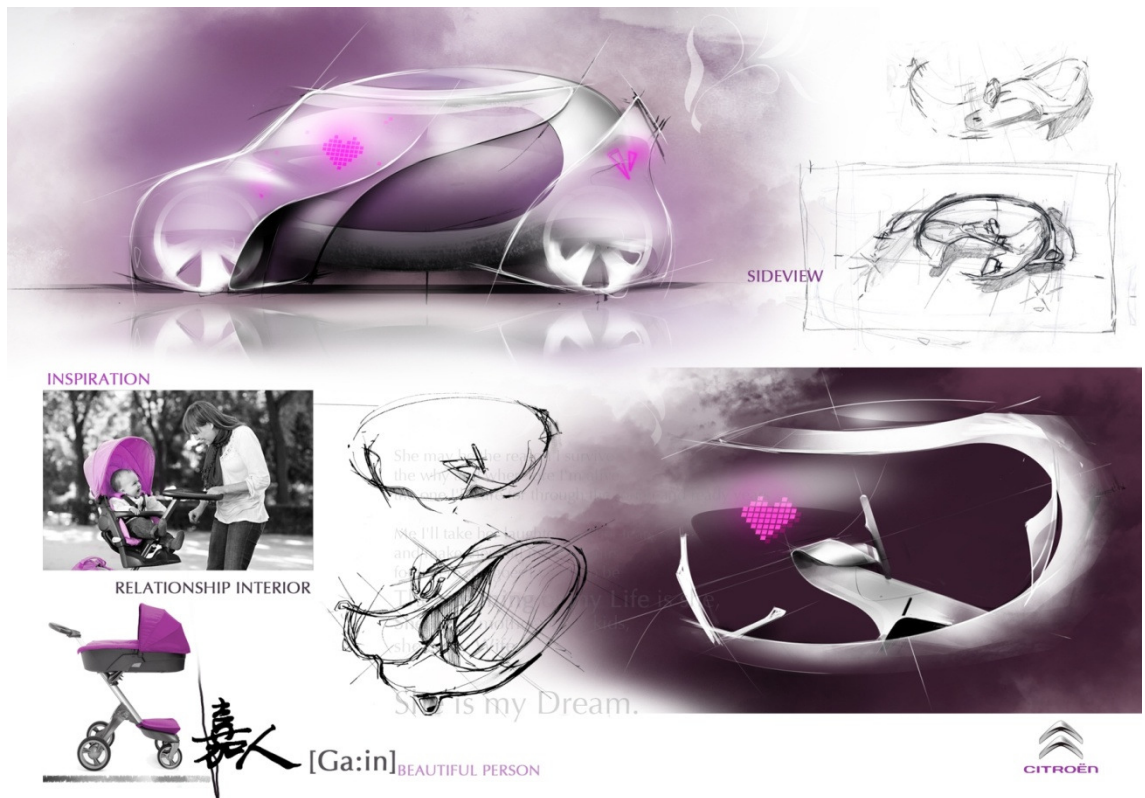


Figure 204: Presentation board for The Boltons Frisbee by Young-Seong Kim (2009).

## 5.2. Fluid and Speed

*'What pushes a pilot to face competition's risks?*

*The success, certainly, I would say. Then the money, and its subsequent advantages.*

*But there should be more.*

*Why do many people love going to race, putting their life into the hands of inconsistency chances?(...)*

*Man, clearly, enjoys risking recklessly his existence for that specific competitive anxiety that, in fact, is one of the few things that distinguishes him from the other species.'*

(Enzo Ferrari, *Piloti, che gente*, 1989)

The creativity of the Italians has interpreted the dynamism that characterizes the 20th century in Futurist paintings, cinema, design, and of course, the automobile, and translated it into style and form. Moreover, speed has evolved into one of the strongest myths of the contemporary world. Before the modern age, the speed of human movement was mostly related to animal locomotion. With the advent of the machine, speed gained an unprecedented dimension. The automobile appeared as the ubiquitous representation of these achievements, and motorsport became the celebration of this new passion. Thus, more than the aeroplane, which rarely provides a way of perceiving its velocity, the automobile generates an aesthetic experience of speed up to the limit of physical objects. However, modern inventions also detached the concepts of perception and contact from physical presence, and created the speed of telecommunication. Speed became an abstract idea. The computer transformed speed from perceiving information to processing it, and we became ever more thirsty for experiences. Whilst the virtual world arrived full of amusements, the natural experiences kept its distinctive qualities.

The Myth of Speed has evolved together with the automobile. Nevertheless, both in motorsport and on the streets, the experience of speed, the heroism and skills behind it, became rarer. Sports cars lost some of their meaning, being inappropriate for road use, rarely used for what they were originally designed for, often becoming hollow status symbols of vanity. Sports cars are still, however, undeniably instruments of pleasure, that can provide the desired delight of speed. However, a revolution is needed in the way we experience this. We need a shift from increasing velocity to increasing sensations, with responsibility and passion. Moreover, in an era when contact with environment will be highly valued, the experience of speed is a link between perception and interaction that brings together man, machine and environment.

### 5.2.1. Speed in the Age of Sustainability

The Myth of Speed was associated with hallucination and bravery. The consequences were dangerous. However, both in motorsport and in road cars, active and passive advances in safety made the automobile less dangerous. In the imagination it became boring, too. Regulations, speed limits, electronic driving aids, all controlled the speed and reduced the experience of driving.

Sports cars evolved by focusing on more power, to achieve faster speeds than the law allows. In addition, this made the sports car an extreme hazard to the environment. The CO<sub>2</sub> emission of the 2010 Lamborghini Murciélago is 480g/km (Lamborghini, 2010). The new electric sports cars, like the Venturi Fétish and the Tesla Roadster, can change this situation, but they cannot guarantee the same quality of experience.

The focus of new design activity must be on enhancing sensations. The sustainable sports car must provide more connections between driver, road, machine and environment. Advances in information technology must be taken on as partners to create safer and, when possible, faster cars. Hypothetically, cars will evolve towards maximum safety with better performance. The importance of the driver's skill will continue to diminish, but his sensations and enjoyment can be enhanced.

The impact of the vehicle on the environment must be reduced, not only in terms of its ecological footprint, but also in terms of aesthetics. The sustainable sports car must blend in with the environment. Instead of producing noise - no matter how pleasant some might argue it was - the sports car should be silent, and capture the sounds from its surroundings, and from its movement through the air.

The smoothness of its movement must allow the driver to receive and sense with more intensity and speed. Thus it brings the experience of speed back inside the vehicle, while the outside environment will be bear less impact from its movement. Moreover, the vehicle must have a shape that moves smoothly, symbiotically with the environment, and not be rigid, as the former *rolling sculptures* were.

To harmonize with the environment, the Myth of Speed will be a representation of the spontaneous movement of nature. The vehicle must be a partner of the dynamism of nature, and use wind and sun as inspiration and energy. In the Age of Sustainability, the experience of speed will belong to nature.



### 5.2.2. Project challenges

One of the most important challenges of this project is to make indulgence part of the Age of Sustainability. As studied in the literature review, sustainability is not about privation, but about getting the best from nature and technology in a responsible way. The objective of the Paradigm Shift project, while investigating aesthetics, is also to make sustainability a pleasant experience.

The sustainable sports car must symbolize a new image of the automobile, in harmony with the environment, providing power without fear. The design language must avoid an association with aggressiveness, but must represent its adventure, joyfulness, and extreme capabilities.

The project searches for beauty and pleasure: the imagination to translate the beauty of movement into a shape. In addition to the brief, another challenge of the project was to bring the dynamism of nature to an artificial object.

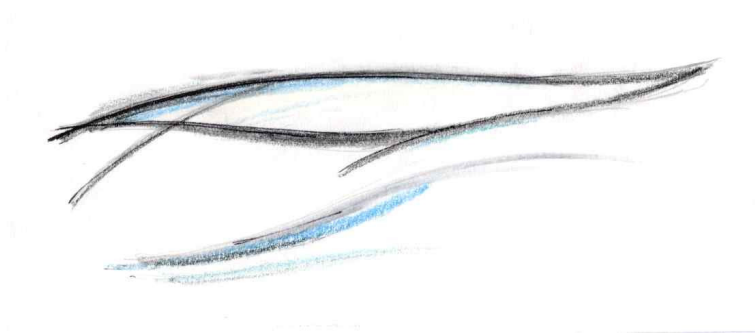
The Mazda Taiki, observed earlier, in the literature review, is an example of design where the dynamism of nature - the movement of the wind - is successfully made solid in a car body. Other designs, developed in an academic context, have explored the enhancement of sensations by making the car more dynamically active. Thus the Phoenix concept, by Sergio Loureiro da Silva (2008), reduces the gap between motorcycles and cars, creating an active body that leans on corners. Additionally, the Phoenix informs the driver about the consumption and generation of energy through changes in its appearance. However, both proposals lack the fluidity and softness that we observe in animals and other natural elements.

Thus the project that investigates a new understanding for the Myth of Speed in the Age of Sustainability was named 'The Fluid Sports Car', and the jellyfish was chosen to inspire its conceptualization.

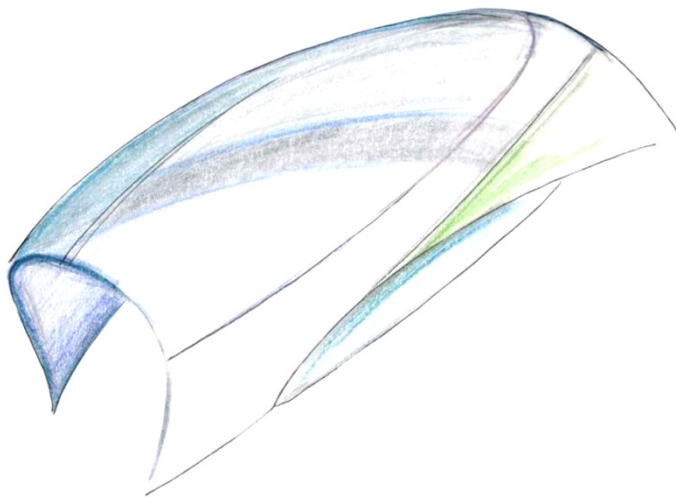
### 5.2.3. Conceptualization phase

The conceptualization of Project Fluid was done in two stages. Firstly, the aesthetic was investigated through intense sketching. Most of the sketching phase was developed in 2009, at the Brazilian seaside, in order to experience the connection to nature. The drawing sessions encompassed abstract and non-automotive themes, to break with established paradigms.

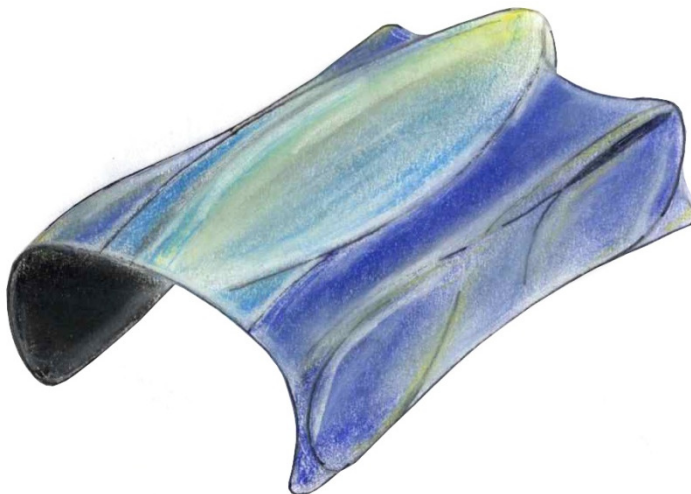




**Figure 205: Investigative sketch of fluid lines (2008).**



**Figure 206: Investigative sketch of marine animal shape (2008).**



**Figure 207: Sketch of the Fluid (2008).**

The sessions were done in cycles, starting with line drawings, representing dynamism; then creating shapes, mostly inspired by marine animals; and finishing with sketches that were closer to automotive language (figures 205-207).

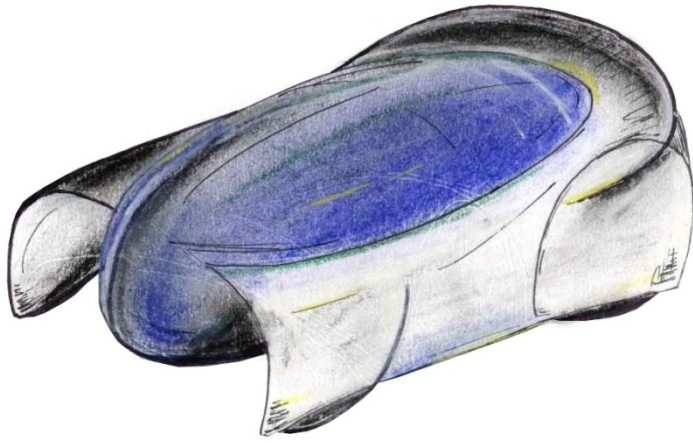


Figure 208: Sketch of the Fluid (2008).

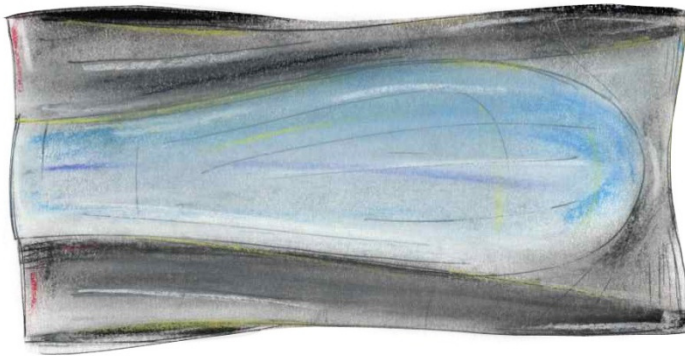


Figure 209: Sketch of the Fluid, top view (2008).

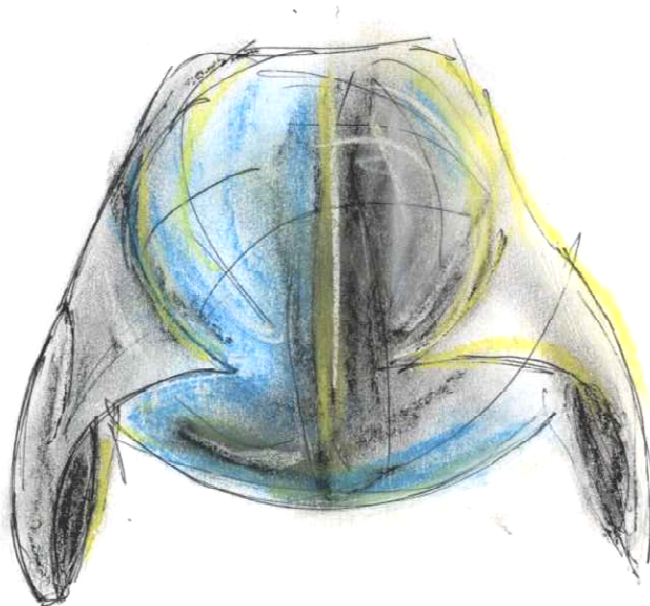


Figure 210: Sketch of the Fluid, front view (2008).

The sketching phase was not intended to resolve the design. A group of draft sketches (figures 208-210) were selected to start the modelling phase, with a significant amount of freedom in the development of the shape. Together with the model, the conceptualization also took shape during this time, as well as research into materials to express and embody the aesthetic. A bio-resin, with transparency and flexibility, was selected to express the aesthetic and functional intentions of the model (figures 211-213).

The Fluid Sports Car concept I have developed explores the interaction between the vehicle and the environment during movement. In order to minimize the impact while moving, and also in the interests of better performance and safety, the future ecological sports car could incorporate the dynamism of nature into its body. The fluidity of a fish swimming, the symbiosis between animals and the environment are translated into a flexible car body.

The dream of speed, agility and dynamism running through the entire history and pre-history of the automobile is preserved and stimulated in the concept. Unlike many ecological car proposals, the Fluid Sports Car aims to enhance the pleasure of driving – or travelling - but blending the vehicle and the environment more harmoniously.

To create a flexible body, with dynamism similar to that of an animal, the concept is made of natural and recyclable resins. The design concept also encourages research into latex and starch-based resins as substitutes for materials obtained through more environmentally harmful processes. Instead of being sourced from mined (and thus finite) resources, the principal material of the car body can be grown as crops – and thus be renewable. The Fluid Sports Car concept also encompasses the application of information technology and nanotechnology to create a fully dynamic car body, therefore also creating a completely different aesthetic experience when compared with rigid, steel-bodied cars.

Like the Aerospace, this concept is not fully developed in terms of utility. Nevertheless, in a complex product like an automobile, simplicity helps to keep the focus on the designer's message. The subtraction of utility creates a stronger aesthetic reference point. Sudjic (2008) explains that some designs are less useful than others, and they are the ones that enjoy a higher status than others. Thus art works evoke our aesthetic experience directly, by touching our spiritual side, and research in the border between art and design becomes an important route to the development of the language of sustainable design. Sudjic (2008) also points out that 'that there is as much to be gained from exploring what objects mean from considering what they do and what they look like'. The Fluid Sports Car

concept reflects the aspirations of a society based on ecological principles, occurring in harmony with auto-mobility, speed and beauty.

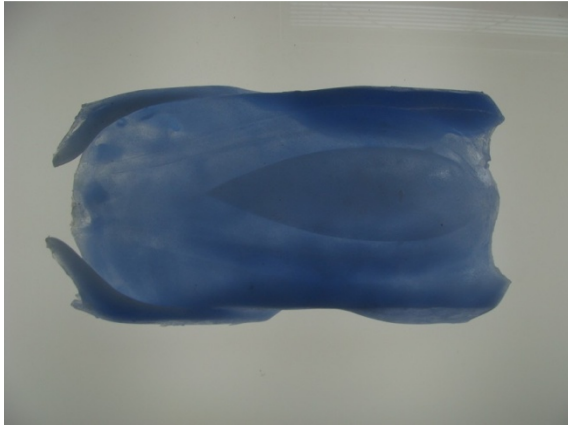


Figure 211: Bio-resin model of the Fluid Sports Car (2008).

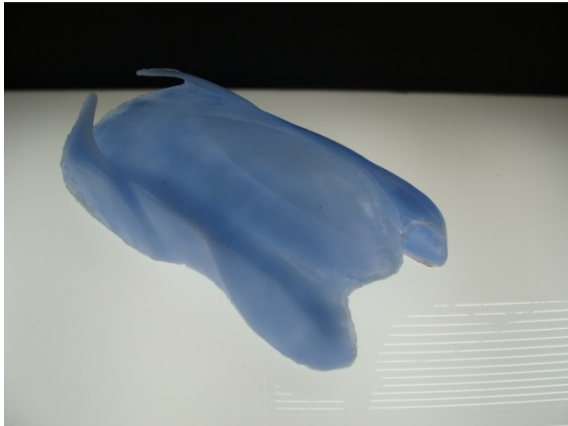


Figure 212: Bio-resin model of the Fluid Sports Car (2008).

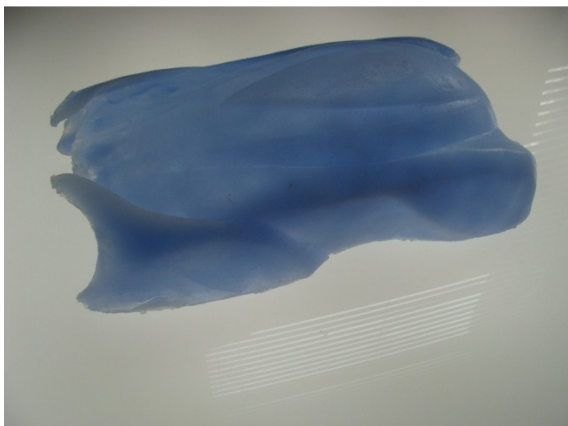


Figure 213: Bio-resin model of the Fluid Sports Car (2008).

## 5.2.4. Experimentation phase

The experimentation phase was carried out with the collaboration of MA students from the Vehicle Design Department of the RCA. Eight students from the first year worked on the Paradigm Shift - Fluid Project.

**Final Brief** | The brief for the Fluid Project added to the general brief shown above:

Sports cars celebrate the machine that they are – large wheels, large air inlets and exhausts, long hoods over loud engines, etc. But in the future the sports car experience may bypass the machine and go for a more animalistic approach, to deliver the purest connection between driver and road, just like a fish in the sea or a bird in the air: it will be about “feeling movement”.

Spend one day researching non-typical flexible automotive materials to use in, and lead the direction for, a new type of dynamic vehicle design. From this research, design a car, or aspects of a car, that focus on connecting the driver to the driving experience.

The designs developed by the students are shown and described in the following section.

**Fluid Sports Car by Julliana Cho** | Figure 214 | Inspired by natural surfaces, with a structure resembling pixels, and dubbed ‘interactive intelligence’, Julliana Cho’s design creates a moving surface shaped around the body of the user. The drive is conducted partly by navigation, and partly by the driver, who can also relax and just experience the speed. In addition, a flow of information runs through the car ski, in optical fibres, and gives the car a surrounding halo-like, shape of light that expands and integrates the car with the environment.

**Fluid Sports Car by Murray Westwater** | Figure 215 | Murray Westwater’s design for the Fluid Sports Car was based on an architecture that is reduced to a second skin for the driver. The driver ‘wears’ a car made of a keratin structure and keratin and collagen skin, and drives it instinctively. The limbs of the driver feel the movement of the vehicle directly. The driving position enhances the experience and thrill of speed. The car is merely an extension of the human body.

**Fluid Sports Car by Elizabeth Pinder** | Figure 216 | Elizabeth Pinder also proposed the sports car as a body extension. Her design for the Fluid explores the emotional attachment and sense of achievement of creating a car that grows together with the driver, through physical exercise. Elizabeth used carbon nano-tubes as muscle and tendons that grow and shape the car that floats above the ground with acoustic levitation. Elizabeth's Fluid creates a life cycle, and at the end of life, the car dissolves the matter into energy.

**Fluid Sports Car by James Brooks** | Figure 217 | James Brooks' design is founded on the assumption that there will be no space for sports cars, but smaller vehicles will substitute for the automobile to retain the experience of speed. James' design is closer to a roller-skate than a car. The driver is wrapped in armour that is the vehicle itself. The position of the body determines the speed and intensity of the sensation of speed. The aesthetic is less Biomorphic, but still resembling an arachnid.

**Fluid Sports Car by James Harness** | Figure 218 | In the design by James Harness, human power is maximised by electric motors, creating a hybrid vehicle that can, hypothetically, reach 100mph. The driver rides inside the small vehicle, in a prone position, to enhance his/her perception of speed and improve aerodynamics. The vehicle body is made of shape-shifting surfaces that cover the wheels and the driver. The design language does not take inspiration from nature, as proposed in the brief.

**Fluid Sports Car by Hitesh Panchal** | Figure 219 | Hitesh Panchal's design was developed focusing on a relationship with the man-made environment. His Fluid interacts with roads of energy, through which the car flows, and at the same time the energy flows through the car. At high speeds, the car creates a tunnelling effect, seen from both the outside and inside. The shape of the car tends towards the organic, inspired by stingray shells.

**Other results** | Two students failed to answer to the brief.





Figure 214: Presentation board for the Fluid Sports Car by Julliana Cho (2009).

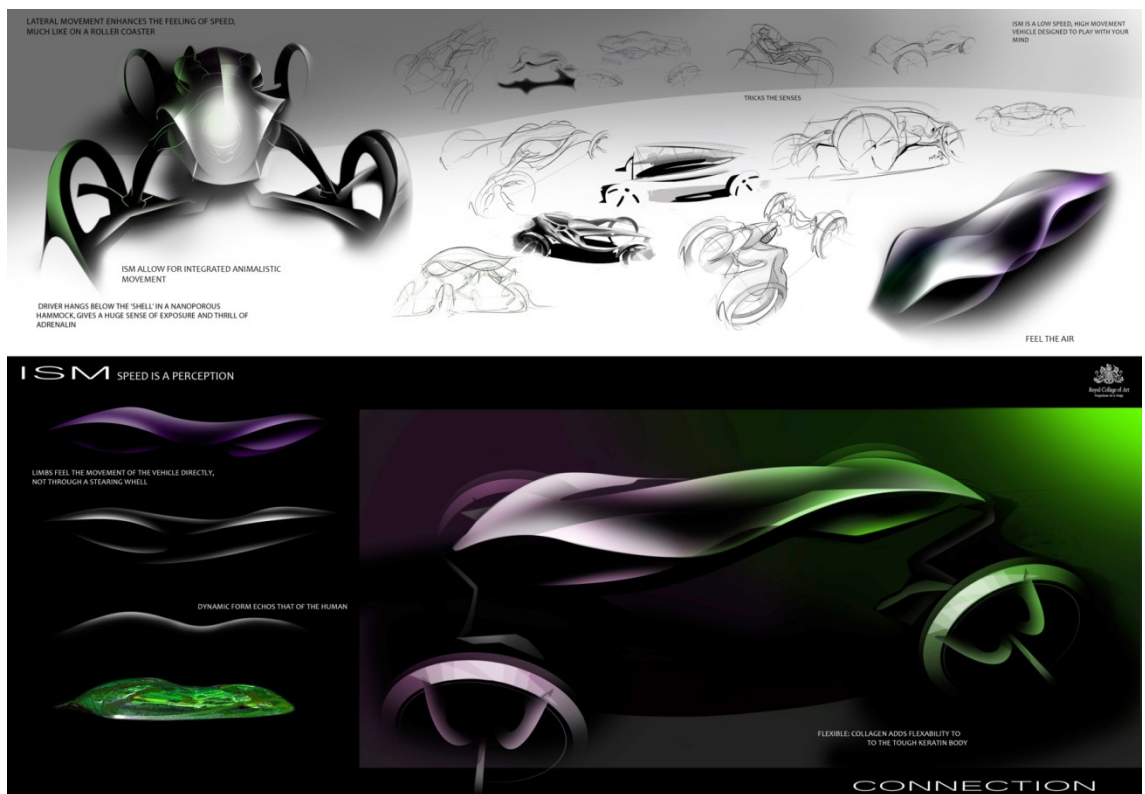


Figure 215: Presentation board for the Fluid Sports Car by Murray Westwater (2009).





Figure 216: Presentation board for the Fluid Sports car by Elizabeth Pinder (2009).

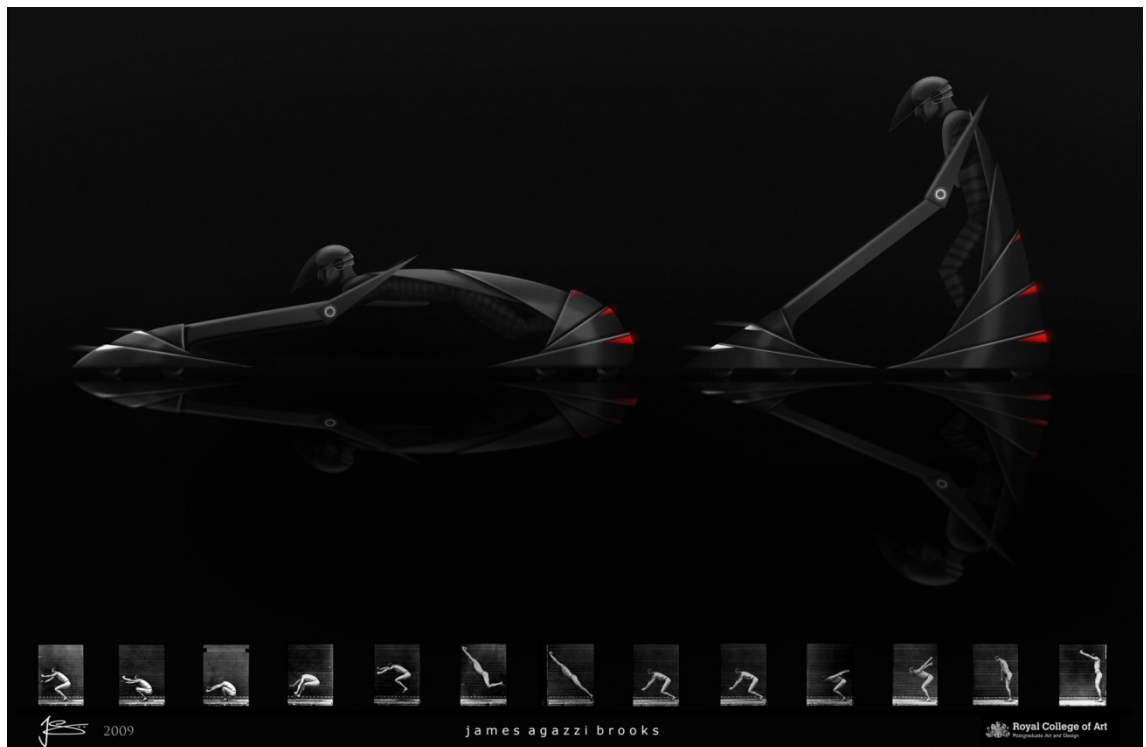


Figure 217: Presentation board for the Fluid Sports Cars by James Brookes (2009).



Figure 218: Presentation board for the Fluid Sports Car by James Harness (2009).



Figure 219: Presentation board for the Fluid Sports Car by Hitesh Panchal (2009).

### 5.3. Core and Comfort

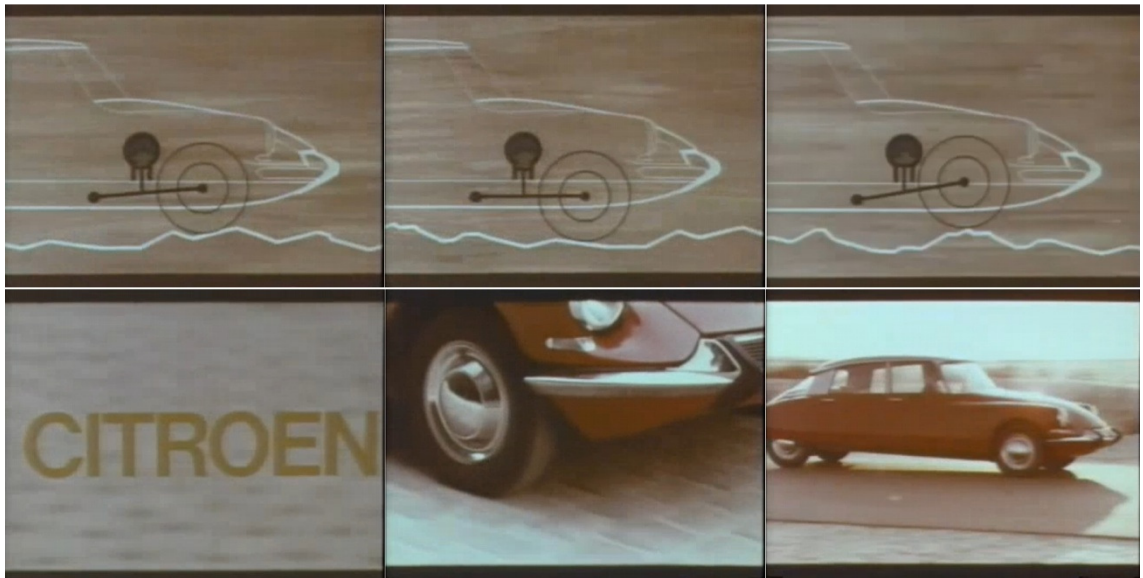


Figure 220: Film stills from the TV commercial for the Citroen DS (Citroen, 1963).

An essential reason why humans transform the environment and make tools and shelters is to obtain comfort. Comfort is not a luxury, but a basic need. Comfort can be either emotional or physical; however, both are connected through our aesthetic experience. Comfort determines our response to all of the contextual experiences described by Walker (2001). In their interaction with the physical world, humans look for comfort. In the search for meaning, human beings seek emotional comfort in a spiritual context. Finally, the concept of solidarity and humanity are ethically linked to comfort in a social context.

The wide range of the Myth of Comfort encompasses more than just the automobile. The production of goods and objects to make our life more comfortable has gained an elevated status in society. A world where everything can be done with no effort, by simply pushing a button, has become a questionable, but ubiquitous, image of the future.

The Promethean ability of humans to create comfort was confronted by the threat of the climate crisis. In this new context, it has been understood that, sometimes, the way one obtains comfort can negatively affect the life of others and the environment. In parallel with the development of an ecological consciousness, a fear of being deprived of the comforts of modern life has developed. Considered one of the worst menaces to the environment, the automotive myth of comfort has had to be rethought. The Rolls-Royce, the Citroen DS (fig.220) and many others, provided comfort to the transporting of people and families, and created standards that must now be improved in a sustainable way.

### 5.3.1. Comfort in the Age of Sustainability

The same principle that applied to the other Myths is valid for that of Comfort. The paradigm shift promotes a new interpretation of the meanings to obtain benefits that are in accordance with the context of sustainability. The reinterpretation of the Myths indicates new objectives, focused on the needs and aspirations of the user.

Considering that the achievement of sustainable mobility is possible, we will continue to enjoy the comfort of the automobile. It is also acknowledged, as mentioned in the earlier section discussing the Myth of Freedom, that limitations to car use will apply.

Nevertheless, in a wider context, the automobile will continue to be used for transport between cities, and also for tourism and leisure and long-distance commuting. Thus the car must provide time for oneself.

In the context of the Age of Sustainability, the interaction, both between users and machine, users and information, and between the users themselves, will be valued and stimulated. To have information, alone, is a comfort in the coming age.

According to the principles of sustainability, universal accessibility to the benefits of culture and industry are compulsory. The sustainable automobile has to be inclusive.

In terms of aesthetics an important shift is to understand nature as a provider of emotional and physical comfort. The enjoyment offered must encompass the physical interaction with, and aesthetic experience of the natural environment, to enhance our respect and responsibility. Thus, the sustainable automobile must promote contact with the environment, being at the same time open and sensitive to surroundings, safe and welcoming.

The recognition of pleasure from this experience with nature also includes the sensory enjoyment of natural materials that may, ecologically, be included in the design of the sustainable automobile. Moreover, with the correct use of natural materials that are renewable and recyclable automobiles will be integrated to bio-cycles.

### 5.3.2. Project challenges

The third theme of the Paradigm Shift Project intended to investigate, at the same time, the aesthetic response to the Myth of Comfort and the future of family-size vehicles. The most important project challenge that was added to the investigation was the assumption



that, with the increasing intelligence of navigation systems and electronic drive facility, the automobile of the future will not need to be driven.

On the one hand, this represents an ultimate level of comfort, when all the users will become passengers, able to relax and enjoy the journey. The architecture of the car, with the benefits of dedicating less space to the powertrain, will then focus on the user. The sustainable automobile can be designed around the user, and without the need for a driver the internal layout will open up an extended range of possibilities. Thus the design will also suit a new family culture in which the figure of the father as the leader and higher authority will be substituted by another, with more equality and knowledge. The interior layout of the vehicle will represent the democracy of the sustainable society.

On the other hand, the challenge of the project is to provide a driverless vehicle with the sensation of control. The project aims to preserve the sovereignty of the user above the machine associated with free will and auto-mobility. Otherwise, a driverless vehicle can generate a feeling of being adrift to the passengers. Thus the design must be developed to enable driverless cars to feel safe.

### 5.3.3. Phase of conceptualization

The objective of the conceptualization phase was to respond to the initial questions and create a brief for the design of a car interior. Initially I investigated new possibilities for layout and architecture through sketches (figure 221).

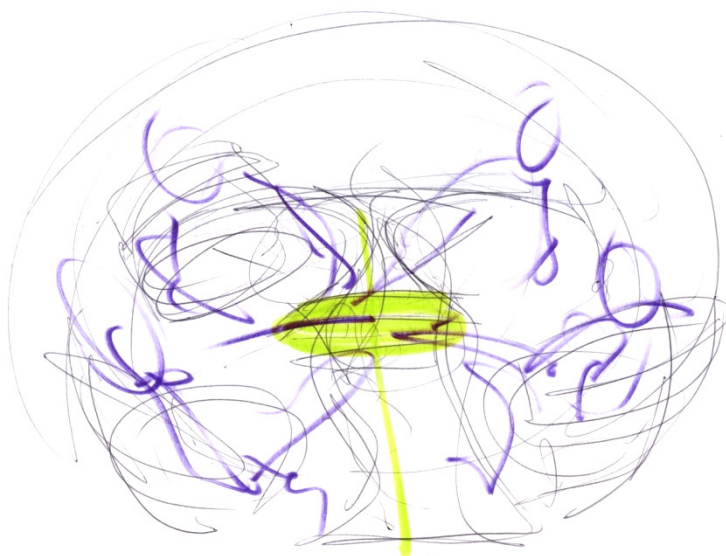
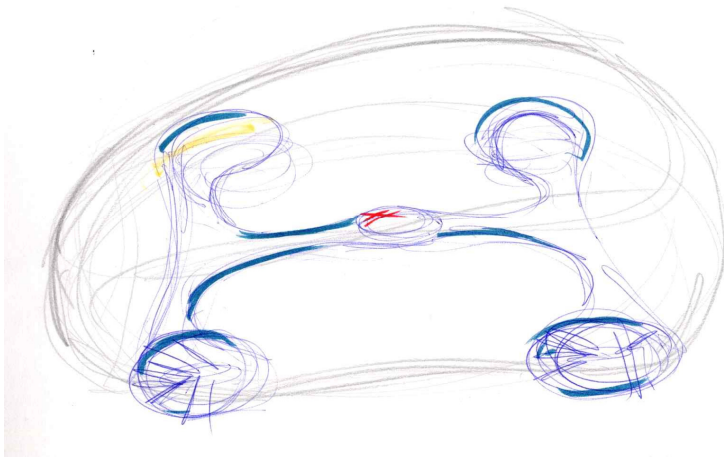


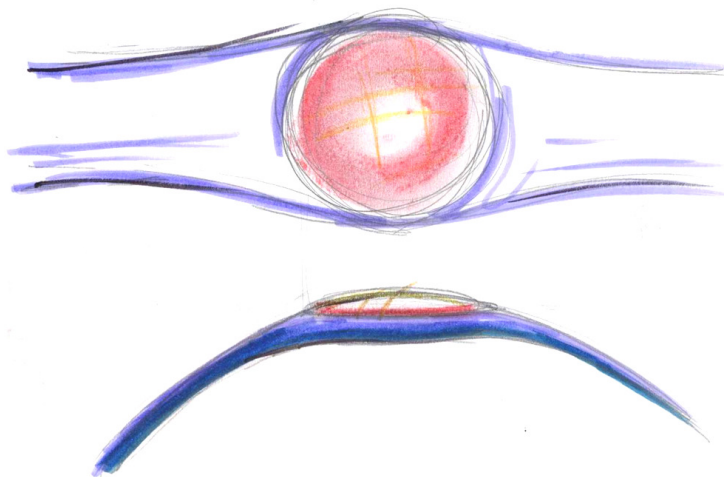
Figure 221: Sketch of passengers interacting in the interior of the Core (2009).

One of the most important paradigm shifts of the project was the removal of the need to use normal driving control mechanisms. Thus the new design will abolish the steering wheel, gears and pedals. Nevertheless, to keep the sensation of control, a new physical interface was investigated.

The control interface will be located in a central position, able to be reached by all passengers, and become the central focus of the interior design. This is known as the Core Control Interface (figures 222-223).



**Figure 222: Sketch of the architecture of the Core (2009).**



**Figure 223: Sketch of the Core Control Interface (2009).**

The Core Control Interface is a navigation system that meshes virtual and natural realities into a constant stream of information. In the context of an electronically-driven automobile, the Core is the interface through which the user can make constant decisions about the journey. The passengers can change the nature of the journey by using this

interface. These passenger decisions concern the navigation; the drive is autonomous. The Core Control Interface is an open source of control, which is available to the passengers independently from where they are sitting in the car: it is possible for it to be moved around the cabin too. The system encompasses the central Interface unit, positioned in the middle of the car, and projections of touch-screen information surrounding the car windows. The central unit is a touch-screen that also gives tactile responses to the users through light movements and changes of temperature or texture. The Core creates a new concept for the car interior, with significantly more interaction between the passengers. Thus, it also reflects on the way the exteriors are conceived, in the interests of enhancing the comfort and the pleasure of the journey.



**Figure 224: Model of the Core in wood (2009).**



**Figure 225: Model of the Core in wood (2009).**

In addition to the sketches, a physical model (figures 224-225) was created, to communicate the concept to the MA students who worked on the following phase. The physical model also aimed to provoke an aesthetic experience related to natural materials. In addition, the model was made in wood to reference the importance of both



craftsmanship and the use of local materials to the contextualization of a design in the Age of Sustainability.

#### 5.3.4. Experimentation phase

The experimentation phase was carried out in collaboration with MA students from the Vehicle Design Department of the Royal College of Art. Four first-year students and two from the second year participated in the group working on the Paradigm Shift - Core Project.

**Final brief |** The brief for the Core Project added to the general brief showed before:

Currently, we enter our destination into a 'sat-nav' and then drive the car according to its instructions. The family car of the future will be autonomous for many journeys, with drivers selecting a destination, but also contributing variously to the speed of the journey and other aspects of the way in which the car is driven and the routes it takes.

Choose a route and spend one day researching the factors that in the future will impact on a family's needs and desires on a journey along this route by an autonomous car. From this information, design the car's Core Control Interface and show how this might impact on the interior design of the car.

By adding a description of the route, it was possible to observe how the design would adapt to different uses, according to the different stages of the journey. The students chose a route in Africa, of the end of the 21st century. The designs they developed are shown and described in the following section.

**Core by Rui Guo |** Figure 226 | Rui Guo designed the interior of a car that a family would use, in the example he described, for a leisure trip from Ghana to Mauritania. His interior design has a strong connection to a traditional car interior layout. Rui proposes that the Control Interface should be shared, with each passenger having a unit next to them, instead of there being only one central unit. Rui's Core Control Interface also allows the car to be driven in an ergonomically convenient way. Located in the arms of seats, the interface is tactile, and communicates by producing various vibrations and textures. The interface also behaves as an educational tool, through which the adults can teach their children how to drive. All the required visual information is projected onto the windows

around the car. The flexibility of the layout is achieved by using the rails installed in the roof, where the control units and back seats roll up, and can be folded.

**Core by Shawn Deutchman** | Figure 227 | Shawn Deutchman's design for the Core also allows the user to drive the car in specific situations. Shawn's car has two very well-defined configurations of use. The first one is the use of the car to commute and to make long journeys through electronically-controlled highways, when it does not need to be driven. In this situation, the car is a comfortable lounge, with big seats, and a big digital screen, used for leisure and the navigation of the car. The second situation is the driving mode. Shawn's Core can be driven off-road for pleasure: in this case, the driver's seat rises up to the roof, creating a flying-deck cockpit. The driving configuration uses the traditional steering wheel. The car roof can also open or be set at a range of heights, using a system that includes a leather belt that wraps round the car body.

**Core by Ian Kettle** | Figure 228 | Ian Kettle investigated a design language that originated in the use of the centrality of the Core as the starting point for a revolving shape. The layout of the interior is created around the Core Control Interface. The passengers sit on a circular sofa around the Core, and the sofa itself can assume a range of different ergonomic settings, according to the occasion. The revolving movement of Ian's Core is extended to the exterior, to create an aesthetic connection between the two parts.

**Core by Richard Bone** | Figure 229 | Richard Bone's Core is a hovering vehicle, much bigger than the traditional car. Richard's Core can only be used for travelling long distances. The design is focused on creating a large interior space that can be designed like a boat or house. The Core Interface is placed in a helmet that can be used by one or many people at the same time. The Core Interface communicates directly with the user's senses. In addition, satellite spaces, either for isolation or for observation of the exterior, can be added to the vehicle.

**Core by Adam Kerr Phillips** | Figure 230 | Adam Kerr Phillips' design for the Core is inspired by biological forms and patterns. Adam (2009) proposes that the vehicle will be grown in a bio-factory, and its aesthetic appearance is a consequence of the fusion of natural and artificial metabolisms. The Biomorphic design language of the exterior follows that of the interior. The car captures energy from the sun through its body, and 'the petals' that fly softly around the body. The car, being a bio-active object, also has the capacity to

mimic the natural environment. Thus, when it reaches its destination in a trip to the countryside, the car becomes a cave, where the family spends the night. Adam's Core is a living cocoon, with the ability to change its shape and transparency. Inside the car, the Core Control Interface works as a tactile surface that controls the car's exterior shape, its interior functions and entertainment, and its navigation. In addition, there are interactive projections on the car windows.

**Other results** | One student failed to answer to the brief.



Figure 226: Presentation board for the Core by Rui Guo (2009).



Figure 227: Presentation board for the Core by Shawn Deutchman (2009).

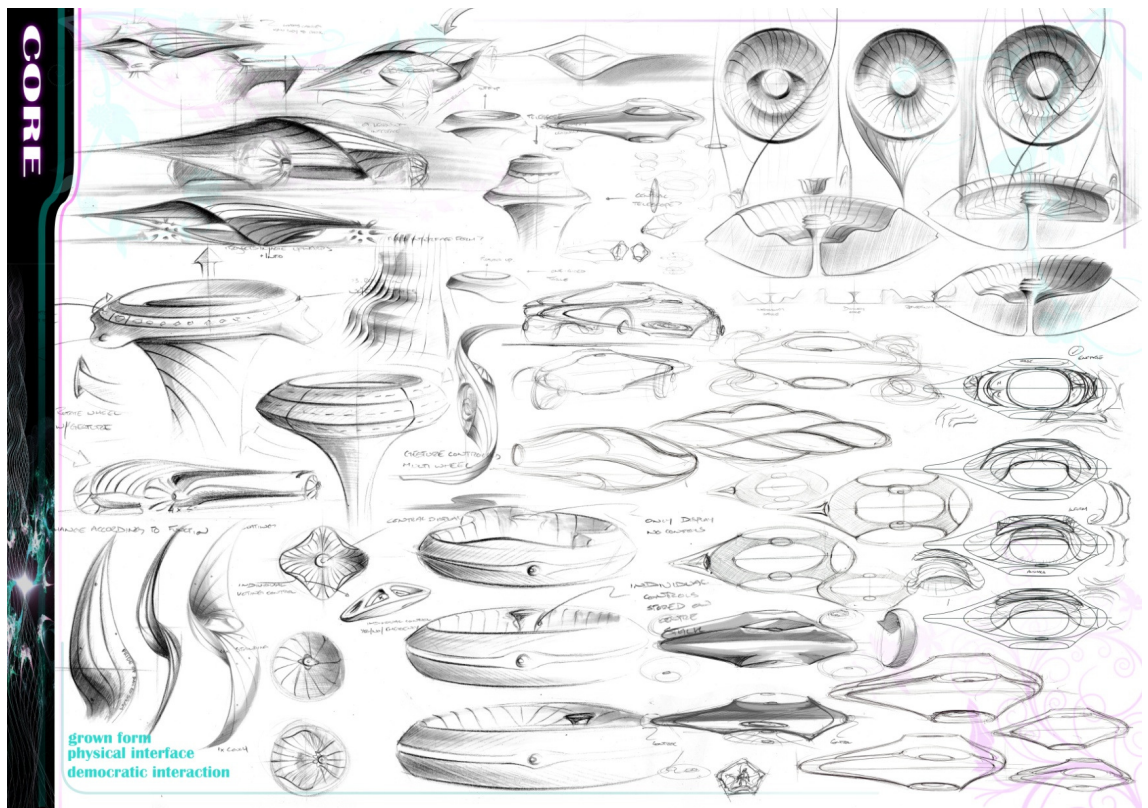


Figure 228: Presentation board of the Core by Ian Kettle (2009).



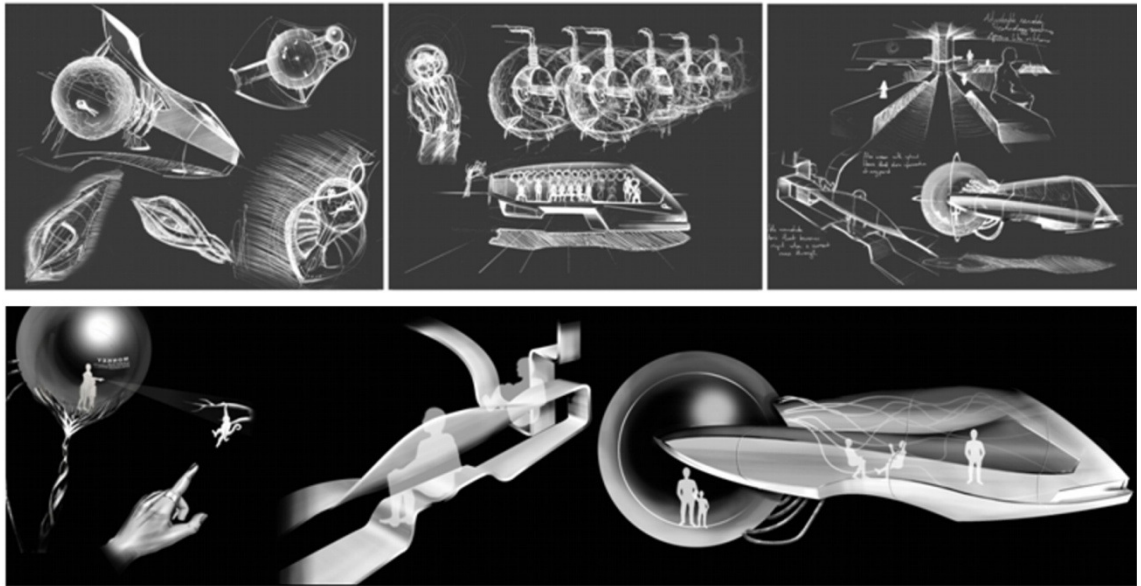


Figure 229: Presentation board for the Core by Richard Bone (2009).

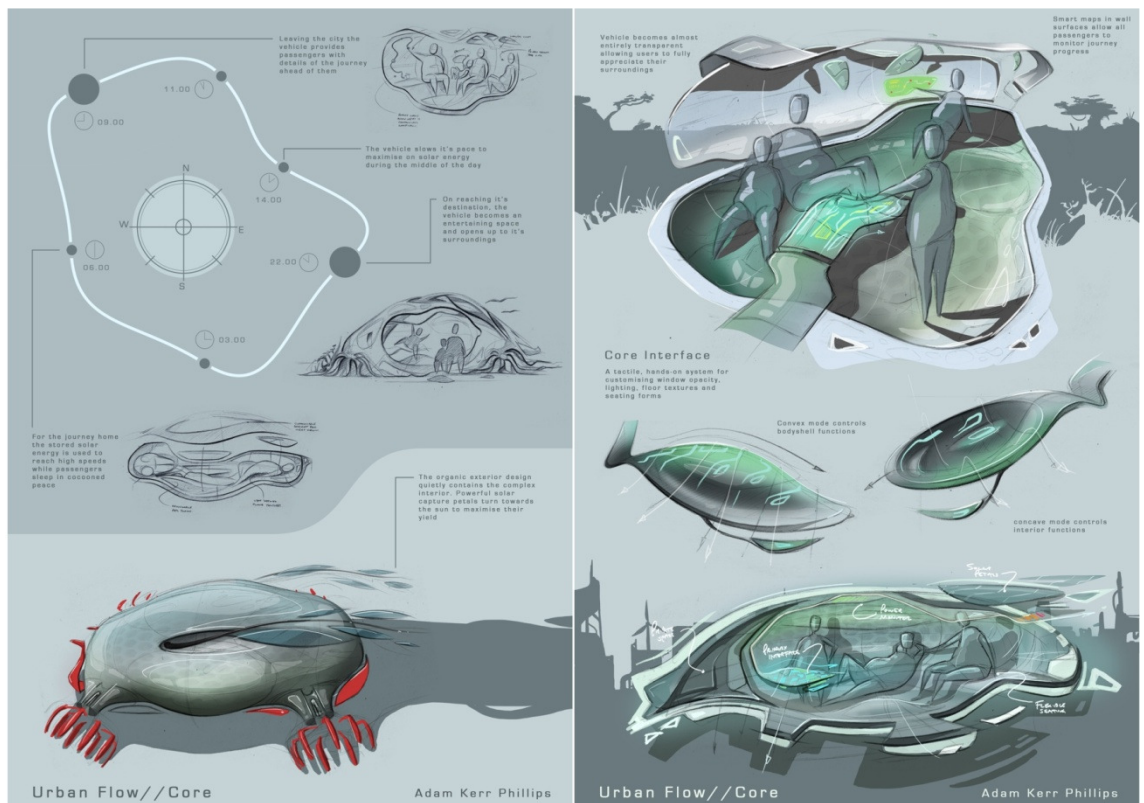


Figure 230: Presentation board for the Core by Adam Kerr Phillips (2009).

## 5.4. Evaluation



Figure 231: Debate with Christopher Reitz (left), Design Director of Alfa Romeo (2009).

As mentioned in the methodology, the Paradigm Shift Project was evaluated in a debate with an important designer from the automotive industry. The aim of the debate was to have an impartial judgment of the outcomes and to understand and find out how the methodology used in the project could be useful to the industry, by listening to opinions representing it. The invited designer was Christopher Reitz, Alfa Romeo's Design Director.

Before this debate, the students presented and discussed their work with Vehicle Design department tutors Sam Livingstone and Stéphane Schwarz, and myself. The first presentation, on 16 October 2009, focused mainly on the academic development of the students, and analysed their ability to respond to a design brief rather than discussing the importance of the designs as references for future automobile aesthetics in the Age of Sustainability. Schwarz's opinions about the project, however, are included in the next section.

Later, on 13 November 2009, Christopher Reitz came to the RCA specifically to participate in the debate on the Paradigm Shift Project (figure 231). Also attending the debate was the supervisor for this research, Paul Ewing, research colleagues Louise Kiesling and Lino Vital, and the MA students who had developed the designs. Christopher Reitz's response is transcribed in the following section.

In addition, this evaluation section includes an observation of the design trends that have arisen with the outcomes of the project. These design trends join the ones identified in the literature review about automobile aesthetics in the Age of Sustainability (section 2.2.5).

The final section also shows a summary of the achievements in sustainability and aesthetics, in the Project Chart.

#### 5.4.1. Stéphane Schwarz addresses the Paradigm Shift Project

After following closely the work of the MA students on the Paradigm Shift Project, Stéphane Schwarz (figure 229) answered the following two questions. (Schwarz, 2010)

Do you think the project was a valid exercise to give the students a new understanding of future mobility, one that might help them to create a new aesthetics?

Considering the current and future agendas the car industry is facing, the project came at an appropriate time, and was a good opportunity for them to think "out of the box" and consider future consumer needs and societal changes as central to the process.

In fact it forced them to go beyond the mere aesthetic statement, which is what the automotive industry traditionally focuses on, but to define primarily a new architecture and interface for the human-machine- environment.

Did you think the project has produced paradigm-shift designs?

We have witnessed some thought-provoking design solutions, and, indeed, a shift from car to mobility device, interestingly in many cases with inclusive and holistic values. Good mental gymnastics for the students!



Figure 232: Stéphane Schwarz (left) evaluating the Paradigm Shift Project (2009).



## 5.4.2. Christopher Reitz addresses the Paradigm Shift Project

After seeing the designs for the presentation of Paradigm Shift Project, Christopher Reitz commented on the debate (Mausbach, 2009):

I really enjoyed seeing these ideas. Obviously, being in the industry you are not officially allowed to have these dreams and thoughts anymore, because there are certain parameters that keep pushing, and become, sadly more dominant and important for your daily life. I think that this exercise is extremely important to give new value to a product that we have today, and maybe will run out sooner or later, because of constraints of the environment, because of congestion, because of not being up-to-date anymore, maybe we need something else, and we don't know what is going to happen.

I think the car industry today is a production plant - they are producing products. It is driven by the intention of making a lot of money. What is nice to see, is that the values are changing in some of the products you guys are doing. I think it will be very interesting to bring some of these values to 'my future'. I think there is a lot of emotional value that you are highlighting here that is really interesting. I think it should be, it would necessarily be a big contribution to the industry, what we've seen today.

Considering the Fluid Project, he added:

You guys must be bored with the cars of today. I think the wish to have stronger emotions is very interesting.

Considering the Core Project, he pointed out:

I don't want to call this a car any more . It is a mobility device.

Considering the Frisbee Project he observed:

I think is very interesting that the car can always change.

We were not made to be cloned. We want to be different - more room for customization.

The car is a way to externalize who you are.

I would like to see that. As a petrol-guy, my heart is bleeding by blending a bench and a car, but on the other hand, maybe that's exactly what you need to do. Of course, maybe not everything will be like this. Maybe there will be the other extreme that explores the sensation of speed. Maybe the future will be, that it opens up much more diversity, and much clearer separation of when you use the object.

Furthermore, comparing the methodology of the Paradigm Shift project to industry practices:

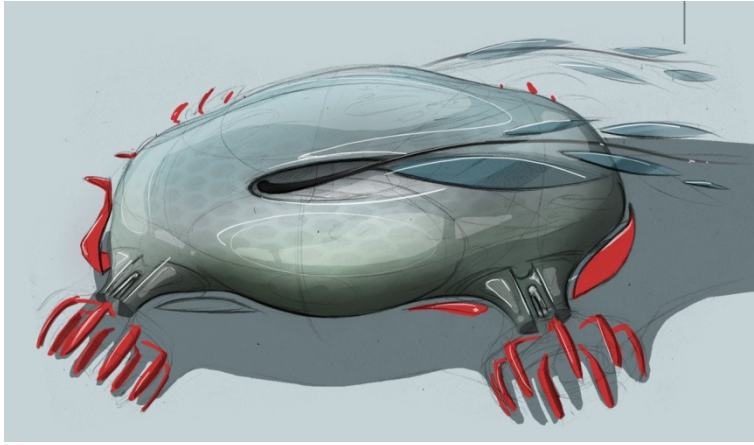
Today we are asked to do something that serves every need. We are supposed to do the sports car that is elegant and is comfortable. It is easy to park, but is very spacious. We try to put everything inside, and that's why, I think, a lot of people think it is boring, because it loses its essence and authenticity. What you are showing is basically the opposite: you take the pure essence and you do a product. And that very nice and interesting. I hope it goes on in this direction.

### 5.4.3. Aesthetics of the Paradigm Shift Project

In the literature review, some trends were identified that are emerging with the ecological concept cars, and creating design trends that might constitute the aesthetic of the Age of Sustainability. Nevertheless, considering the nature of aesthetic evolution, not all the trends will represent a revolution in the design language. This revolution was the aim of the Paradigm Shift Project.

In this section of the evaluation, the trends that have arisen with the designs presented in this chapter are analysed.

**Moving Spaces** | As consequence of the evolution of the electric motor technology, the relative proportions of the spaces for the passengers and the powertrain will change. The sustainable car will have more dedicated space for passengers. This trend started to be observed in the Synthesist and Functionalist designs, presented in the literature review. With the advent of driverless vehicles, the internal layout will be revolutionized. Moreover, some vehicles will be conceived as spaces that move, rather than vehicles with internal space. The passengers' living space will be the main factor that defines the shape of the body and the usability of the vehicle.



**Figure 233: Core by Adam Phillips (2009).**

Adam's Core concept (figure 233) showed an example of this paradigm shift. His design is also influenced by an integration with nature that goes beyond the inspiration of a specific shape.

The Moving Space approach can also create, as observed with Richard's Core design, a number of designs that move closer to architectural spaces or boats than car design.

**Body Extension** | In an opposite direction, the Fluid Project showed designs where the dimensions of the automobiles were reduced to a minimum, to maximize the experience of speed.

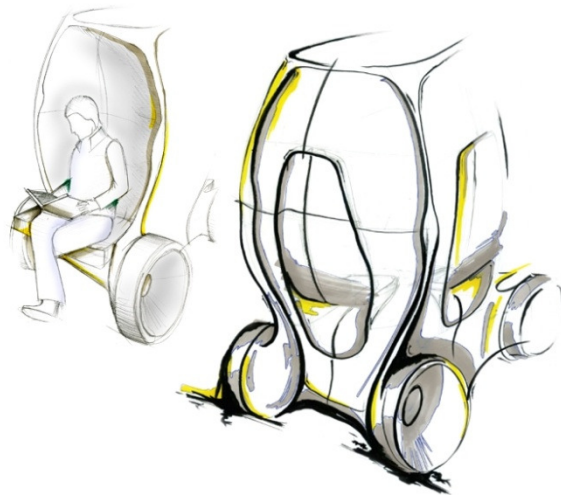


**Figure 234: Fluid Sports Car by Murray Westwater (2009).**

In this context, Murray's Fluid Sports (figure 234) presented a car body that is like a second skin of the driver. The automobile becomes a body extension. Again, when the principle is taken to this extreme, the vehicle can hardly be understood as a car. Nevertheless, as the research showed, what sustainable design aims for is not a product but the results that a

system of products can give. It is interesting to acknowledge that, as different they might be from the automobile, the Segway and the Toyota I-swing were proposed as alternative mobility devices that could also substitute for the automobile. This shift may give a new importance to product design companies connected with car manufacturers, such as Porsche Design.

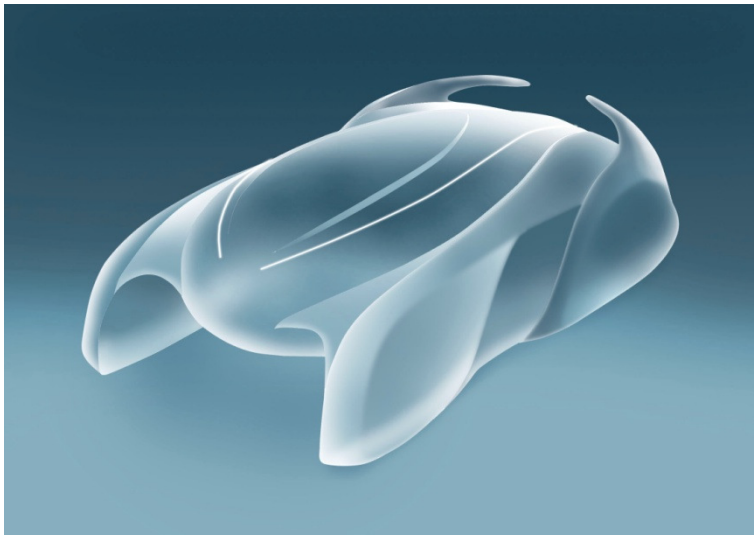
**Active Body** | In the Age of Sustainability, the car body has to be more active, to adapt to different uses and also to add extra utility to periods when it is not commuting. The functionality and aesthetics of Active Body designs will be defined by the ability of its body to change. The main focus of the Active Body is to improve ergonomics and the connection to the user and the community, and to enhance its usability.



**Figure 235: Hoxton's Frisbee by Ido Baruchin (2009).**

The Hoxton's Frisbee designed by Ido Baruchin (figure 235) showed an example of a design language that originates in the multiple usability of a sustainable car. The aesthetic of his Active Body is connected to product design, flexibility, social lifestyle, and Technomorphic and Functionalist trends.

**Biomimetic** | The original design proposal for the Fluid Sports Car (figure 236) explored lively bodies that, in another direction, imitated or were inspired by the behaviour of animals. While the Biomorphic design trend identified in the literature review was inspired in shape and appearance by natural forms, the Biomimetic trend revolutionizes the aesthetic by incorporating metabolisms and motions inspired by nature into the design. The shape of the original Fluid concept was inspired by sea animals, whose motion it also imitates.



**Figure 236: Fluid Sports Car initial concept (2008).**

The Biomimetic trend is characterised by the use of natural materials that can add flexibility to the designs. These materials can be simple, like a bio-resin, or complex genetic designs. The BedZED's Frisbee designed by David Eburah (figure 237) used a genetically-engineered spider silk to create an aesthetic for a car that imitates a natural process of telling the story of its use.



**Figure 237: Frisbee by David Eburah (2009).**

In an extreme development of the Biomimetic trend, the automobile becomes part of a man-made cycle that replicates nature. This was the case with Elizabeth's Fluid Sports, Car, that grows and disappears, like a muscle. The Biomimetic is, in these examples, the ultimate aesthetic interpretation of recyclability.

#### 5.4.4. Sustainability of the Paradigm Shift Project

In order to evaluate the ecological nature of the designs produced by the Paradigm Shift Project, I listed the aspects related to sustainability that were covered or explored in the designs. This empirical evaluation method is advocated by Vezzoli and Manzini (1998) and also coincides with the Mythical approach to sustainability proposed by Walker (2006). The method was adopted because it suits the artistic approach of the project better, and does not question the importance of scientific research, like life cycle analysis, essential to the development of designs at other stages.

The issues explored in the designs are placed in the second part of the Project Chart.

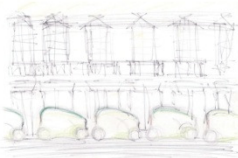
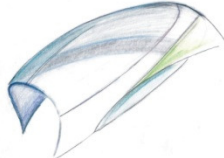

Project	Frisbee	Fluid	Core
Initial Concept			
Aesthetic of sustainability	Form follows function Rough surfaces Enhances connection to product Benefits society Satisfy real needs Expression of a story that one can relate	Mimesis Resonance with nature Aerodynamics Lower impact	Minimalism Presents raw materials Crafts heritage Social interaction
Eco-efficiency	Minimize the content of material Product dematerialisation Cultural identification Facilitate upgrading Collective use	Use of natural materials Low toxicity, biodegradable and renewable materials Adaptation to different functioning requirements Efficient energy consumption Lighten the product Renewable and clean energy sources	Simplify product

Figure 238: Project Chart - part two.

In terms of an aesthetic of sustainability, the designs have investigated the following ideas: form follows function, mimesis, minimalism, rough surfaces, enhancement of the connection to a product, noble presentation of raw materials, resonance with nature, benefits to society, aerodynamics, craft heritage, lower visual impact, satisfying real needs, and the expression of a story a user can relate to.

The eco-efficiency of the designs was enhanced by the following: use of natural materials; minimization of the material content through product dematerialisation; use of low toxicity, biodegradable and renewable materials; use of renewable and clean energy sources; adaptation to different functional requirements; cultural identification; simplification of the product; upgrading facility, efficient energy consumption; reducing the weight of the product, and collective use, among others.

#### **5.4.5. Validation**

Through the evaluation process it was observed that the designs were able to investigate a new interpretation of the Myths of Freedom, Speed and Comfort that configures a change in the values guiding some of the paradigms of the automobile. The designs also present a series of new principles that may reflect on new ways of producing vehicles, providing mobility and new social behaviours. In addition, some of these design trends have created a revolutionary aesthetic.

Whilst the real-life application of the designs seems far away, the aim of the project was to create references to inspire developments in aesthetics and technology, and the designs were well received by industry professionals. At the same time, the project has responded to the guidelines proposed by Walker, Vezzoli and Manzini, key references for this research.

From the author's perspective the designs have exceeded expectations in terms of both the diversity of aesthetic solutions that have emerged and the exploration of the concepts in terms of values and experiences.



## 5.5. Conclusion

The evaluation process showed that the main objectives of the Paradigm Shift project were successfully achieved. The designs succeeded in reframing the aesthetic, based on new and sustainable values and practices. The aesthetic broke away from its 'cage of introversion'.

Without limiting the designs to well-developed technologies, the project investigated the extent of the benefits that it will be possible to achieve in the future, with the appropriate use of new sustainable technologies, unconstrained by aesthetic conventions. In this direction the project created many interesting references for the development of electric cars, from renewed concrete needs and abstract aspirations. Thus, new design concepts must utilize completely this potential for change.

The arrival of new technologies also took unexpected directions. From the use of biofuels to the extreme of the genetically-designed technologies proposed in some of the Paradigm Shift concepts, the insertion of design into bio-cycles must be carefully and ethically examined.

The project showed the importance of working on the early conceptual stages of the design process to change the paradigms. According to Manzini and Vezzoli (1998), this is the most efficient way to reach sustainable solutions. Thus, the project proved that design must be placed at a high decision-making level to develop complete concepts, with meaningful aesthetics instead of superficial styling.

The 'art/design as research' process, was essential to the freedom of creativity necessary for the experimentation with the new aesthetic. Nevertheless, it is recognized that the project is just the start of a mandatory multidisciplinary design process necessary to develop a new automobile design paradigm. Moreover, the project proved that the paradigms of aesthetics and technologies can only be changed by using a whole-design process. Independently if it starts from replacing an inappropriate aesthetic paradigm or an unsustainable technology, the development of more sustainable automobiles will only occur through the development of new design paradigms encompassing the needs of people, place, production and poetry.

## 6. Conclusion, recommendations and future research

### 6.1. Conclusion

This research has investigated several issues that can potentially define the future language of car design. A comprehensive literature review discussed and related the automobile to two broad areas: sustainability and aesthetics. The literature review confirmed the hypothesis of the research that sustainability will be the greatest driver of change in car design. This is a consequence of the need to replace existing paradigms in order to make the automobile more sustainable - and design, as a language that shapes its functional and symbolic messages, will reflect these changes in a new aesthetic paradigm.

The literature review demonstrated the failures of current unsustainable paradigms and their relationship to aesthetics. The evolution of the aesthetics and the process that led to the perception of its stagnation were studied, too. Together, these aspects configure the moment for a paradigm shift. Thus the literature review explained that car design is entering its third age, the Age of Sustainability, that follows the second, the Evolutionary Age, and the first, the Age of Pioneers. The literature review also identified the diversity of trends that characterizes car design, and the ways in which the industry is searching for sustainability. This research was augmented by the case studies, adding evidence that sustainable cars are changing the market and becoming the new automobile icons.

The analysis of the information gathered, both from the literature review and from the case studies, has helped to position the objectives of the project. Significantly, the acknowledgment of sustainability as a modern myth (Walker, 1997), directed the project towards a conceptual approach, better suited to the academic environment of the Royal College of Art. Nevertheless, the concepts were created with respect for the holistic approach that is essential to the development of sustainability.

The project investigated the new aesthetics that can arise from a shift in values, qualities, social behaviours, means of production, design principles and consumer aspirations. The pathway guiding the development of the project was the automotive Myths of Freedom, Speed and Comfort, observed throughout the research. The process, focused on the initial phases of Archer's design model (Cross, 1989), prioritized conceptual solutions in order to create references for the development of aesthetics and technology unconstrained by current paradigms. In spite of having originated revolutionary aesthetics, the need for the concepts to develop in a multidisciplinary way was acknowledged.

The outcomes of the project were linked to car design through the concrete needs and abstract aspirations identified through the research and the reinterpretation of the automotive myths in the context of sustainability. The designs have been identified as revolutionary designs by design professionals. Furthermore, in some cases the vehicle was not seen as an automobile, but it kept the essential benefits the user expects from it. Thus, without limiting the designs to current typologies and well-developed technologies, the methods used were effective in creating revolutionary concepts and reaching a paradigm shift in automobile aesthetics.

The designs produced have indicated how sustainability will change the way we drive, own, feel and understand cars. The Frisbee project investigated the aesthetic experience with new models of ownership and use, and explored the feasibility of the public car. The Frisbee showed that public cars must be developed to match individuals, particular tastes and local culture. The Fluid project demonstrated that the Myth of Speed will continue to be celebrated in the Age of Sustainability. Nevertheless, the focus will be on exploring the experience, instead of merely increasing speed. The designs showed the tendency to reduce the size of the sports car to the limit, seen in the Body Extension trend. On the other hand, the Core project demonstrated that family cars may grow bigger while becoming autonomous Moving Spaces. The Core project also investigated how sustainability and IT will change the way we will travel in the future, and how to add social value to this experience. Consequently, the project showed that image of the automobile will be related to the benefits it produces, from the family to the environment.

Together, the project and the research demonstrate predictions of the aesthetic of the automobile in the Age of Sustainability. Moreover, all the information gathered in the research, and the methods applied in the project, created a body of work that may guide a new approach for the development of vehicle design, especially in the shaping of new design courses, following the principles of sustainability.

In addition, in this chapter the research questions are answered in order to conclude the objectives of this work.

### **How will the tradition of vehicle design influence this new aesthetic?**

The Car Design Timeline, frontispiece of this research, shows graphically the connection between design trends in the three identified ages. The Timeline was developed as a visual support to enable an understanding of how design trends are evolving, and how they will influence the sustainable car of the future. It is clear in the Timeline that the moment a

paradigm shift happens, changes in aesthetics are consequently more significant. This process, occurring from the Age of Pioneers to the Evolutionary Age, will be even more significant when moving to the Age of Sustainability, because of the broader change in paradigms. Whilst many of the concepts for ecological cars are closely linked to old paradigms of technology and aesthetics associated with their brands, the Paradigm Shift Project has explored the aesthetic consequence of renewed ones. Thus the more distant the new paradigm is from the old one the less the new aesthetics will be influenced by the old.

Old paradigms must be changed when they impede the progress of sustainability and aesthetics, even if it may lose its connection with previously successful design language. The development of more sustainable automobiles will only occur through the development of new automotive design and manufacturing paradigms (Andrews et al. 2002), that will be based on values of respect for the environment and society that will initiate a new aesthetic paradigm. This shift will break a circle of repetition that has forced car design to refer constantly to its own past, and imprisoned its aesthetics in a 'cage of introversion'. If the symbols of a past age are not adequate for the new context, they will be an inappropriate block to creativity. Thus a radical and meaningful change in aesthetics will renew car design, as the Modern movement did with architecture. The battle between the new and old aesthetic represents the battle to implement a paradigm shift.

On the other hand, the study also enhances the importance of diversity in design. Through the history of car design, different styles and typologies responded to particular tastes and cultures. This process is respected and should be continued in the Age of Sustainability. Moreover, the communication of the genealogy of a language, or even a brand heritage, can create a feeling of linear evolution that makes the design seem to belong to something longer than its own cycle, or a person to something longer than their life.

Furthermore, historically the car gave humans benefits and dreams that are valued and must be preserved and reinterpreted in a sustainable way. This is the reason why the Paradigm Shift Project searched for the essence of the Myths of Freedom, Speed and Comfort, and has reinterpreted them in the context of the Age of Sustainability. The Myths signify the meanings and the benefits expected from the automobile. The connection of the Paradigm Shift Project to the tradition of car design is not limited to surfaces, or superficial aesthetics, but is founded on the essence of the aesthetic experience of the automobile as a mythical object.

## **Will a new language change the image of the car as an enemy of the environment?**

A new language will only change the image of the automobile if it can be understood as a representation of new values that are not associated with socially and environmentally damaging practices. Therefore the sustainable automobile must have a particular aesthetic, recognizable as distinct from previous ones. Thus, a paradigm revolution is necessary, according to Kuhn (1977); in a paradigm shift, the new paradigm will be incompatible with the old ones, and replace them.

The design trends observed in the Age of Sustainability section of the literature review were mostly influenced by those of the earlier Evolutionary Age. This is because most of the designs are linked to old means of production, use and consumption. In addition, most of the concepts have the intention of preserving a brand heritage reflected through visual symbols. Thus most of the concepts unveiled up to the present day are not likely to change the current image of the car.

An exception can be made for the Communicative designs of the Nissan Pivo and Renault Twizy Z.E. Together with a new architecture, changing the way the vehicle is used, these concepts showed a new way of interacting with the vehicles, implying respect for both society and the environment. The Venturi Astrolab is also revolutionary: Lakic's concept proposes a new understanding of the sports car, that transforms motoring within a sustainable practice.

The Paradigm Shift Project has proposed different approaches to car design, based on sustainable practices and renewed values and qualities, producing design concepts that make the car more compatible with the environment and society. Significantly, the Frisbee Project has shown examples of car use that transforms it into a benefit to the community rather than the individual user. In addition, as seen in designs for the Core and Fluid Projects, the use of the car must be understood as a way to experience and enjoy nature, with respect and without a negative impact.

## **What will be the relationship between technology and aesthetics in the sustainable car?**

The research identified that the electric motor may soon replace the internal combustion engine, and guide the development of new car architecture. This must, of course, be done using sustainable sources of electricity. More importantly, the research has identified that the constraints on design will progressively reduce with the development of electric car architecture and battery technology, and the user and the environment will both benefit.

At this moment in time, hybrid technologies can provide an important reduction in consumption and emissions. Whilst the hybrid powertrain adds more constraints and complexity to the designs, it also provides resources to research into battery technology and the electric motor.

The evolution of sustainable technology will move faster when its application becomes more common. In the sustainable car of the future, the constraints will diminish and the vehicle will be designed to focus more on the user. The Paradigm Shift Project also explored the influences of information technology on the future context. Notably, car architecture will shift from ICE and being mechanically-driven to EV and being electronically-driven. The information technology that has changed the way information travels will change the way we travel too.

At the same time that the design constraints will diminish, or become more flexible, the technology that is representative of a sustainable practice will be explored in the design language as an expression of a new image of the automobile. Thus sustainable technology will not need to be hidden, and the aesthetic will be more authentic.

Developments in biotechnology also will influence the new aesthetic. The use of natural - recyclable and renewable - materials will increase, and their aesthetic qualities will become more valued, because they are also symbols of sustainable practices. Lighter materials, like bio-resins and natural textiles, will be more common in the automobile. The most radical designs of the Paradigm Shift Project showed that genetically-engineered materials may also be incorporated into the designs in such a way as to bring to the automobile a natural cycle.

The ethical implications of this involvement in natural cycles must be carefully examined. The speed and the scale of automobile industry production can hardly follow bio-cycles. Significantly, until now eco-design products have generally searched for bio-compatibility and have shown a more extensive use of natural materials, while ecological car design has been influenced more by techno-cycles and improvements in the direction of non-interference. When the mixture of techno-cycles and bio-cycles becomes more likely to guide the evolution of car design, the study of industrial ecology becomes essential.

### **How will the aesthetic of the automobile manifest itself in an Age of Sustainability?**

The two different approaches to sustainable design, bio-cycles and techno-cycles (Manzini and Vezzoli, 1998), will determine the most important differentiation of languages in

future aesthetics. The Technomorphic and Biomorphic trends, as explained in the literature review, represent this duality. The main technologies that will evolve as more biocompatible, with less interference with natural cycles, will dictate most revolutionary aesthetic trends. The aesthetic of the Technomorphic trend has manifested itself through the extensive presence of virtual reality and IT, shapes defined by aerodynamic concerns, moderate references to car design heritage and the intention of harmonizing with the built urban environment. The aesthetic of the Biomorphic trend has manifested itself through the use of bio-materials, organic shapes, minor references to car design heritage and the intention of harmonizing with the natural environment. Nevertheless, because in industrial ecology the two approaches will often be combined, the languages may also be mixed.

The revolutionary paradigms will replace the previous ones. The aesthetics of the automobile in the Age of Sustainability will be completely different from the ones in previous ages. The sustainable car will be nothing like the unsustainable car. The paradigm shift in aesthetics will occur with the end of traditional car design and the introduction of revolutionary and sustainable whole-design concepts with semantic reference to meaningful values of respect to people and environment.

The aesthetics will be manifested with more diversity, with respect to local culture and individuality. Thus many design trends will continue to exist. Most of them will be totally disconnected with the trends of the Evolutionary Age, but some will still try to refer to past symbols. Nevertheless, when the new paradigms become ubiquitous, the conservative trends will disappear together with traditional car design, remaining only the trends of sustainable car design.

This research has studied the concepts of ecological cars in order to understand the character of current trends. The trends observed were classified as: Functionalist, Biomorphic, Technomorphic, Cockpit Body, Conservative, Synthesist, Clean Shape and Communicative. The Paradigm Shift Project has produced designs that are revolutionary, and have required a new classification. To explain these trends, they have been classified as: Moving Spaces, Body Extension, Active Body and Biomimetic. Of course, the project was an experiment, and the trends may or may not emerge in future production cars. Furthermore, other trends, not listed above, may also appear.

Nevertheless, the most important characteristic of the new aesthetics will be that the automobile will be a symbol of respect for society and the environment. The aesthetic will



be a meaningful and clear representation of the values and qualities that guided the design. Moreover, as the Paradigm Shift Project has showed, positive experiences will be enhanced in the design, specially the connection to nature and humanity. The automobile in the Age of Sustainability will not be only a useful auto-mobility device, but also an inspirational object that harmonizes people, place, production and poetry.

## 6.2. Recommendations

In the course of the research, a number of issues that could be considered problems facing the automotive industry were identified. The literature review has included recommendations and design methods, from Papanek to Walker, for the development of products and services in the direction of sustainability. In addition to referring to the existing knowledge, this research has investigated how sustainability can be a driver of a paradigm shift in aesthetics.

The following recommendations are addressed to both industry and academia in relation to the development of automobile aesthetics in the Age of Sustainability.

- Old paradigms must be abandoned if they are hindering the development of technology and aesthetics.
- Design must not be used to hide the qualities and values of a product. The design language must be a true representation of the design qualities. Thus the conflict between aesthetics and ethics will not exist.
- Car design must incorporate 'the alternative' more. More sustainable materials and energy must be progressively incorporated into in the automobile to support the development of these technologies.
- Car design must be developed based on a holistic understanding of the context. The product must be developed for the local, and care about the global.
- Designers must work in multidisciplinary teams to reach sustainability.
- Designers in the academic environment must use their relatively wider freedom to create concepts that inspire the research and development of more sustainable technologies. Their designs must also reference new habits, and these ideas must be communicated to society as a whole.
- Designers from industry and the academic worlds must develop a new language that communicates the sustainable character of the designs. On the one hand, sustainable vehicle design must be taught in academia. On the other, the industry must re-structure and direct design departments and product research and development towards sustainability.
- Designers from industry must approach scientific and academic communities who are investigating sustainable technologies, who are not limited by the routine parameters of the industry.

- Industry must change from providing products to providing the results of systems of products and services, developed from a holistic understanding of their functional and symbolic meanings.
- This research recommends designing from the essence.

### **6.3. Future research**

This research is not conclusive, and has not attempted to become the final word on the subjects under discussion. It is rather an addition to an ongoing investigation that may lead to the greatest paradigm shift ever seen in the history of the automobile.

The original contribution of this research is a design methodology that is based on qualities and values that bring together aesthetics and sustainability. In addition, the project has shown a series of concepts that, using this methodology, has presented original interpretations of the aesthetics of the automobile in the Age of Sustainability. The aesthetic is analysed and classified by design trends. The study of design trends followed the work of other researchers, and will require a continuation in the future. At the moment, these future trends are predictions - useful tools for designers, researchers and industry. In the future, the structure of the Car Design Timeline may be used, replacing the predictions, however, with actual designs.

Among the many ideas that emerged from the Paradigm Shift Project, there are some that deserve to be investigated in depth by both designers and scientists. Significantly, the use of flexible bio-materials appeared in many concepts, with different objectives. Research into these materials and their application will definitely help the development of car design towards sustainability.

The new typologies, linking the automobile with street furniture, deserve more exploration as solutions to the lack of space in the urban context, and in terms of the need to give more utility options for the automobile when it is parked.

Whilst this research was about the automobile and sustainability, one of the most important outcomes was the acknowledgment that the focus of design should be the results of a system and product, rather than merely a product. Consequently, some of the concepts of the Paradigm Shift Project are not recognizable as cars, even if they provide the same goals. Thus, it will be important to develop a similar project as non-automotive research.

Moreover, the convergence of the areas of aesthetics, psychology and design must be more intensively studied by researchers from all these fields, in order to create a better understanding of the fundamental nature of the connection between human beings, the automobile and the environment that will direct the future of car design in the context of sustainability.

# Bibliography

AJANOVIC, A.; HASS, R.; NAKICENOVIC, N. (2007) 'Assessment of alternative fuels for road transport'. Conference Paper. In: MASMOUDI, A. (ed.) *EVER International Conference on Ecological Vehicles and Renewable Energies*. March 2007. Monaco: France: Technical University of Vienna and EVER.

ANDREWS, S.D.; SIMPSON, A.; NIEWENHUIS, P.; EWING, P.D. (2002) "Developing a sustainable automotive design paradigm", Research Paper. In: *6th Annual Environmental Engineering Research Event*, Blackheath 2002, NSW.

ANDREWS, S.D.; NIEWENHUIS, P.; EWING, P. D. (2005) 'Black and Beyond – Colour and the Mass-produced Motor Car; Colour in Design in Natural and Engineered Worlds'. In: *Journal of Optics and Laser technology* special issue. Jolt 1233.

ANDREWS, S.D.; SHACKLOCK, EWING, P.D. (2005) 'The Evolution of land-based locomotion: the relationship between form and aerodynamics for animals and vehicles with particular reference to solar powered cars'. In: M. W. Collins, M. A. Atherton, J. A. Bryant. (eds.) *Nature and Design*. London: WIT Press

ANDREWS, S. D. (2006) *Life Cycle Assessment and the Design of Ultra-Low and Zero Emission Vehicles in the UK*. Thesis (PhD), Imperial College of Science, Technology and Medicine. London: Imperial College.

ANDREWS, S.D.; NIEWENHUIS, P.; EWING, P.D. (2007) 'Living Systems, 'total design' and the evolution of the automobile: the significance and application of holistic design methods in automotive design, manufacture and operation.' Chapter 13 in: J. A. Bryant, M. A. Atherton, M. W. Collins (eds.) *Design and Information in Biology – From Molecules to Systems*. WIT Press.

ANFAVEA. (2007) *Brazilian Automotive Industry Yearbook 2006*. Research Report. Sao Paulo: ANFAVEA.

ARCHER, Bruce. (1984) 'Systematic method for designers'. Chapter in: ARCHER, B. (ed.) *Developments in design methodology*. Chichester: John Wiley & Sons.

ARCHER, Bruce. (1996) *Course in research methods*. London: Royal College of Art.

AVERE. (2008) *What are EVs?* Available from: [http://www.aveer.org/what\\_are\\_evs.htm](http://www.aveer.org/what_are_evs.htm). [Accessed in April 2008].

BARTHES, Roland. (1957) *Mythologies*. London: Vintage.

BARUFFALDI, Silvia. (2007a) 'New, as long as it's Smart'. In: *Auto & Design Magazine* 162. Torino: Auto & Design.

BARUFFALDI, Silvia. (2007b) 'An asymmetric concept'. In: *Auto & Design Magazine* 164. Torino: Auto & Design.

BARUFFALDI, Silvia. (2008a) 'A leap into the future'. In: *Auto & Design Magazine* 170. Torino: Auto & Design.

- BARUFFALDI, Silvia. (2008b) 'Electric architecture'. In: *Auto & Design Magazine 173*. Torino: Auto & Design.
- BAYLEY, Stephen (1999) 'Introduction: Shaped by a century'. Chapter in: BAYLEY, S. and CHAPMAN, G. (eds), *Moving objects: 30 years of design at the Royal College of Art*. London: Eye-Q.
- BAYLEY, Stephen. (2008) *Cars Freedom Style Sex Power Motion Colour Everything*. London: Conran Octopus.
- BELLU, Serge. (2008) 'Symbol for an anniversary'. In: *Auto & Design Magazine 170*. Torino: Auto & Design.
- BETTER PLACE. (2009) *Better Place: the global provider of electric vehicles networks and services*. Available from: <http://www.betterplace.com/>. [Accessed in September 2009].
- BIRKELAND, Janis. (2002). *Design for sustainability: a sourcebook of integrated solutions*. London: Earthscan.
- BMW. (2008) *BMW at the 78<sup>th</sup> International Geneva Motor Show 2008*. Booklet. Munich: BMW Group.
- BMW. (2009) *Sustainability by design: taking responsibility action*. Booklet. Munich: BMW Group.
- BUCKLEY, Martin and REES, Chris. (2006) *The world encyclopaedia of cars*. London: Lorenz Books.
- CALLIANO, Alberto. (2007) 'A shape for hydrogen'. In: *Auto & Design Magazine 164*. Torino: Auto & Design.
- CAR DESIGN NEWS (2007a) 'Nissan Pivo' . Available from: <http://cardesignnews.com>. [Accessed in December 2009].
- CAR DESIGN NEWS (2007b) 'Toyota 1/X' . Available from: <http://cardesignnews.com>. [Accessed in January 2010].
- CASTILHO, M.; STRAUB, E.; DE QUEIROZ, H. and BIONDAN, P. (2006) *ABC do rendering automotivo*. Curitiba: Infolio.
- CHAPMAN, Giles. (2007) *Chapman's Car Compendium: The essential book of car facts and trivia*. London: Merrell.
- CINTI, Fulvio (2009) 'Design plays musical chairs in the crisis'. In: *Auto & Design Magazine 176*. Torino: Auto & Design.
- CLEAN GREEN CARS. (2008). *Clean Green Cars: The Green Motoring Guide*. Bremner, R (ed.) available from: <http://www.cleangreencars.co.uk>. [accessed in April 2008]
- CONWAY, Gavin. (2007) 'Jaguar E-type'. In: *Automobile Magazine Vol. 22, No.6*. September 2007. New York: Source Interlink Media.
- CORNIL, Daniele. (1997) 'Metropolitan Art'. in: *Auto & Design Magazine 104*. Torino: Auto & Design.

- COROLLER, Patrick. (2007) 'Last developments in the fields of the ecological vehicles and the future prospects'. Conference Paper. In: MASMOUDI, A. (ed.) *EVER International Conference on Ecological Vehicles and Renewable Energies*. March 2007. Monaco: France: French Committee of Clean Vehicles and EVER.
- CROSS, Nigel. (1989) *Engineering design methods*. Tiptree: John Wiley & Sons.
- CUMBERFORD, Robert. (2005) 'Story of an era: the good and the bad'. In: *Auto & Design Magazine 150*. Torino: Auto & Design.
- CUMBERFORD, Robert. (2006) 'The import of good design'. In: *Automobile Magazine Vol. 21, No. 6*. September 2006. New York: Source Interlink Media.
- CUMBERFORD, Robert. (2007a) 'Nostalgia has its limits'. In: *Auto & Design Magazine 165*. Torino: Auto & Design.
- CUMBERFORD, Robert. (2007b) 'Tumble What? The strange and baffling world of car designer-speak explained'. In: *Automobile Magazine Vol. 22, No.5*. August 2007. New York: Source Interlink Media.
- CUMBERFORD, Robert. (2007c) 'Change around the corner'. In: *Auto & Design Magazine 166*. Torino: Auto & Design.
- CUMBERFORD, Robert. (2008a) 'Bugatti Type 35: the best racing car design of all time'. In: *Automobile Magazine Vol. 23, No. 6*. September 2008. New York: Source Interlink Media.
- CUMBERFORD, Robert. (2008b) 'Dodge Ram: the next generation big rig'. In: *Automobile Magazine Vol. 23, No.96*. December 2008. New York: Source Interlink Media.
- CUMBERFORD, Robert. (2009a) 'Crisis, what is the answer'. In: *Auto & Design Magazine 175*. Torino: Auto & Design.
- CUMBERFORD, Robert. (2009b) '1999-2005 Audi A2'. In: *Automobile Magazine Vol. 23, No. 12*. March 2009. New York: Source Interlink Media.
- CUMBERFORD, Robert. (2009c) 'Design analysis'. In: *Automobile Magazine Vol. 23, No. 12*. March 2009. New York: Source Interlink Media.
- CUMBERFORD, Robert. (2009d) 'Alfa Romeo 8C 2900B'. In: *Automobile Magazine Vol. 24, No.5*. August 2009. New York: Source Interlink Media.
- CUMBERFORD, Robert. (2009e) 'BMW Vision: Designer's delight'. In: *Automobile Magazine Vol. 24, No.9*. December 2009. New York: Source Interlink Media.
- CUMBERFORD, Robert. (2009f) 'The Fiat-Chrysler deal'. In: *Auto & Design Magazine 178*. Torino: Auto & Design.



- DANISH ARCHITECTURE CENTRE. (2008) *Ecotopedia: walk the talk*. Exhibition Journal. 11. *Mostra Internazionale di Architettura - La Biennale di Venezia*. September - November 2008. Venice: Danish Architecture Centre.
- DATSCHEFSKI, Edwin. (2001) *The total beauty of sustainable products*. East Sussex: RotoVision.
- DESAI, Pooran and KING, P. (2006) *One Planet Living*. Bristol: Alastair Sawday.
- DESIGN COUNCIL. (2009) 'Alison Black's User centred Design Glossary' In: *Design Council Website*. Available from: <http://www.designcouncil.org.uk> . [Accessed in September 2009].
- DUNLOP (2009). *Geneva Motor Show Press Kit*. [CD-ROM]. Geneva: Dunlop Europe.
- EDSALL, Larry. (2008) *Auto e Design: I maestri dello stile* .Vercelli: White Star.
- EVENDEN, Helen. (2007) *Moving Forward: New Directions in Transport Design*. London: V&A Publications.
- FAGNOLA, Ferdinando. (2008) ' Il Sogno Infinito'. In: MOLINIERI, G and TUMMINELLI, P. (2008) *Dream l'auto del futuro dal 1950*. Torino: Umberto Allemandi.
- FELICOLI, Riccardo P. (1998a) *Walter de'Silva: Centro Stile Alfa Romeo*. Milano: Automobilia.
- FELICOLI, Riccardo P. (1998b) *Sergio Pininfarina: Pininfarina Studi & Ricerche*. Milano: Automobilia.
- FRANCA, Ronaldo. '70 questões para entender o etanol'. In: *Revista Veja* 19/03/2008. Sao Paulo: Editora Abril.
- FRAYLING, Christopher. (2006) *What is research?*. [Lecture]. London: Royal College of Art.
- FUAD-LUKE, Alastair (2002). *The Eco-Design Handbook – New Edition*. London: Thames & Hudson.
- GANDINI, Marzia. (2004) 'The shape of the hybrid'. In: *Auto & Design Magazine* 145. Torino: Auto & Design.
- GANDINI, Marzia. (2007) 'Marine influence'. In: *Auto & Design Magazine* 167. Torino: Auto & Design.
- GANDINI, Marzia. (2008) 'Three dimensional flows'. In: *Auto & Design Magazine* 168. Torino: Auto & Design.
- GALVANO, Fabio. (2008a) 'Windscreen wiper goodbye'. In: *Auto & Design Magazine* 170. Torino: Auto & Design.
- GALVANO, Fabio. (2008b) 'Formal flexibility'. In: *Auto & Design Magazine* 172. Torino: Auto & Design.
- GALVANO, Fabio. (2009c) 'An intriguing hi-tech mix'. In: *Auto & Design Magazine* 178. Torino: Auto & Design.
- GHK (2006) *A study to examine the benefits of the End of Life Vehicles Directive and the costs and benefits of a revision of the 2015 targets for recycling, re-use and recovery under the ELV Directive*. Research Report. London: GHK Group.

- GLANCEY, Jonathan. (2003) *The car: a history of the automobile*. London: Carlton Books.
- GORE, Al. (2006) *An Inconvenient Truth*. London: Bloomsbury.
- GOODYEAR. (2009) *Goodyear Efficient Grip. Geneva Motor Show Press Kit*. [CD-ROM]. Geneva: Goodyear.
- GOLDMAN, Alan. (2001) 'The Aesthetic'. Chapter in: GAUT, B. and LOPES, D., *The Routledge Companion to Aesthetics*. New York: Routledge.
- GOTT, Philip. (2008) 'Is Mobility As We Know It Sustainable?' Conference Paper. MASMOUDI, A. *EVER International Conference on Ecological Vehicles and Renewable Energies*. March 2008. Monaco: Global Insight and EVER.
- GRAY, Carole. (2006) *Visualising research*. [Lecture]. London: Royal College of Art.
- GRAY, Carole and MALINS, Julian. (2004) *Visualising research*. Burlington: Ashgate.
- HADID, Zaha. (2006) Interview with Todd Gannon. In: GANNON, Todd (ed) *Zaha Hadid: BMW Central Building*. New York: Princeton Architectural Press.
- HALL, Peter. (1988) *Cities of tomorrow: and intellectual history of urban planning and design in the twentieth century*. Saffron Walden: Blackwell.
- HASEGAWA, Yozo. (2008) *Clean car wars*. Singapore: John Wiley & Sons.
- HEIMANN, Jim and PATTON, Phil. (2009) *20th Century classic cars: 100 years of automotive ads*. Cologne: Taschen.
- HICKMAN, Leo. (2005) *A good life: the guide to ethical living*. London: Transworld Publishers / The Guardian.
- HOLLANDE, Marianne. (2007) Interview with Artur Grisanti Mausbach, Monaco, March 2007.
- HOLLOWAY, Hilton and BUCKLEY, Martin. (2002) *20th century cars: the complete guide to the century's classic automobiles*. London: Carlton.
- HOLMBERG, J. (1995) *Socio-Ecological Principles and Indicators for Sustainability*, Goteborg: Institute for Physical Theory.
- HULL, Nick (2007) 'Mazda Taiki'. Available from: <http://cardesignnews.com> [Accessed in September 2009].
- INTERGOVERNMENTAL PANEL ON CLIMATE CHANGE (IPCC ) (2007) *Climate Change 2007: Synthesis Report*. Research Report. Paris: UNEP.
- JACOBS, Jane. (1961) *The death and life of great American cities*. New York: Random House.
- JANAWAY, Christopher (2001). 'Plato'. Chapter in: GAUT, B. and LOPES, D., *The Routledge Companion to Aesthetics*. New York: Routledge.

- JENCKS, Charles. (1977) *The language of post-modern architecture*. London: Academy Editions.
- JENNINGS, Jean (ed.). (2006) 'The 25 most beautiful cars of all time'. In: *Automobile Magazine Vol.21 No.6*. September 2006. New York: Source Interlink Media.
- JENNINGS, Jean (2007a) 'Alfa Romeo 8C 2900' . In: *Automobile Magazine Vol. 22, No.6*. September 2007. New York: Source Interlink Media.
- JENNINGS, Jean (ed.) (2007b) 'The bug's (second) life'. In: *Automobile Magazine Vol. 22, No.9*. September 2007. New York: Source Interlink Media.
- JENNINGS, Jean (ed.) (2009) 'Connoisseur's guide to hybrid systems '. In: *Automobile Magazine Vol. 23, No.12*. March 2009. New York: Source Interlink Media.
- JOHNSON, Philip and WIGLEY, Mark. (1988) *Deconstructivist architecture*. Exhibition catalogue: The Museum of Modern Art. New York: New York Graphic Society Books.
- JORDAN, M. (2006) 'Tesla Roadster: proof of concept'. In: *Automobile Magazine Vol 24, no.8*. November 2009. New York: Source Interlink Media.
- KACHER, George. (2008) 'Smart's start'. In: *Automobile Magazine Vol 22, no.11*. February 2008. New York: Source Interlink Media.
- KACHER, George. (2009a) '2010 Mercedes-Benz S400 Hybrid and Lexus LS600hL'. In: *Automobile Magazine Vol 24, no.5*. August 2009. New York: Source Interlink Media.
- KACHER, George. (2009b) 'Lamborghini Miura'. In: *Automobile Magazine Vol 21, no.8*. November 2006. New York: Source Interlink Media.
- KACHER, George. (2010) 'Audi E-tron'. In: *Automobile Magazine Vol 24, no.10*. January 2010. New York: Source Interlink Media.
- KEMENES, FORSBERG, MELACK. (2008) 'As Hidroeletricas e o Aquecimento Global'. In: *Ciencia Hoje 245*. Rio de Janeiro: SBPC.
- KIMES, B and GOODFELLOW, W. (2005) *Speed, Style, and Beauty: Cars from the Ralph Lauren Collection*. Boston: Museum of Fine Art Publications.
- KLOESS, AJANOVIC, HAAS. (2008) *A Dynamic Analysis of the Economics of Alternative Vehicles and Fuels in Austria up to 2050*. Conference Paper. MASMOUDI, A. *EVER International Conference on Ecological Vehicles and Renewable Energies*. March 2008. Monaco: Technical University of Vienna and EVER.
- KOSTOF, Spiro. (1991) *The city shaped: urban patterns and meanings through history*. London: Thames & Hudson.
- KUHN, Thomas S. (1962) *The structure of scientific revolutions*. Chicago: University of Chicago Press.

- KUHN, Thomas S. (1977) *A tensao essencial*. Lisbon: Edicoes 70.
- LAKIC, Sacha. (2007) Interview with Artur Grisanti Mausbach, Paris, April 2007.
- LAKIC, Sacha. (2008) Interview with Artur Grisanti Mausbach, Paris, October 2008.
- LAMBORGHINI (2010) *Automobili Lamborghini*. Available from: <http://www.lamborghini.com/> . [Accessed in February 2010].
- LE CORBUSIER (Charles-Édouard Jeanneret-Gris).(1929) *The city of to-morrow and its planning*. London: John Rodker.
- LIDWELL, Larry W., HOLDEN, Kritina and BUTLER, Jill. (2003). *Universal Principles of Design*. Gloucester: Rockport Publishers.
- LONGMAN (1995) *Longman Dictionary of Contemporary English. Third Edition*. Harlow: Longman.
- LORIO, Joe. (2007) 'Military jeep'. In: *Automobile Magazine Vol. 22, No.6*. September 2007. New York: Source Interlink Media.
- LUCIE-SMITH, Edward. (1984) *The Thames and Hudson Dictionary of Art Terms*. London: Thames and Hudson.
- LUPFER, G., PAUL, J; SIGEL, P. (2006) '20th century', in: EVERS, B (ed). *Architectural Theory*; Cologne: Taschen.
- MACEY, Stuart and WARDLE, Geoff. (2008) *H.Point: The fundamentals of car design & packaging*. Pasadena: Art Center College of Design.
- MACKENZIE, Dorothy. (1991) *Green design: design for the environment*. London: Laurence King.
- MALDONADO, Tomas.(2006) 'Mitomacchina i Altri Miti.' In *Mitomacchina – Il design dell'automobile: storia, tecnologia e futuro*. Milano: Skira.
- MANZINI, Ezio. (1992) 'Prometheus of Everyday: the ecology of the artificial and the designer's responsibility' in: BUCHANAN, R. and MARGOLIN, V. (eds), *Discovering design: explorations in design studies*. Chicago: University of Chicago Press.
- MANZINI, Ezio and VEZZOLI, Carlo.(1998) *Lo sviluppo di prodotti sostenibili*. Rimini: Maggioli Editore.
- MANZINI, Ezio. (2006) 'Design for sustainability. How to design sustainable solutions.' Research Paper of INDACO and Politecnico de Milano. In: *Ezio Manzini's Blog*. Available from: <http://www.sustainable-everyday.net/manzini/>. [Accessed in October 2009].
- MARCHIS, Vittorio (2008) 'Volare su quattro ruote: il sogno dell'ingegnere' In: MOLINIERI, G and TUMMINELLI, P. (2008) *Dream l'auto del futuro dal 1950*. Torino: Umberto Allemandi.
- MARGOLIUS, Ivan. (200) *Automobiles by Architects*. London: Wiley-Academy.

- MARINETTI, F. T. (1909) 'Futurist Manifesto (Manifeste du futurisme)' in *Le Figaro on 20 February 1909*. Paris: Le Figaro.
- MASDAR. (2008) *The Masdar Development*. Electronic Media. Abu Dhabi: Masdar.
- MATERA, Eugenio and PIETROGRANDE, Patrizia. (2008) 'Il Mito della velocità. Per una storia della velocità nel Novecento italiano' Chapter in: MATERA, Eugenio and PIETROGRANDE, Patrizia. (eds.) *Il Mito della Velocità. Arte, motori e società nell'Italia del '900*. Florence: Giunti.
- MAUSBACH, A.G. (2008) 'The Influence of Architecture on the Aesthetic of Sustainable Cars'. Conference Paper. In: MASMOUDI, A. *EVER International Conference on Ecological Vehicles and Renewable Energies*. March 2008. Monaco: RCA, CAPES and EVER.
- MAUSBACH, A.G. (2009) *Paradigm Shift project: debate with Christopher Reitz*. [Digital video recording] Royal College of Art, London, November 2009.
- MAYER, Ralph. (1969) *A dictionary of art terms and techniques*. London: A&C.
- McCARTY, Tom. (2007) *Auto Mania*. London: Yale University Press.
- McCORQUODALE, Duncan; HANAOR, Cigalle. (2006) *Recycle: The Essential Guide*, London: Black Dog Publishing.
- McMAHON, Jennifer A. (2001) Chapter in: GAUT, B. and LOPES, D., *The Routledge Companion to Aesthetics*. New York: Routledge.
- MENGA, Pietro. (2008) 'An Evaluation of Eco-sustainability of 'clean' Vehicles'. Conference Paper. In: MASMOUDI, A. *EVER International Conference on Ecological Vehicles and Renewable Energies*. March 2008. Monaco: CEI-CIVES – Italian AVERE Section and EVER.
- Metropolis* (1927), Directed by Fritz Lang. Germany: UFA.
- Modern times* (1936), Directed by Charles Chaplin. USA: United Artists.
- MOLINERI, Giuliano. (1999) *Giorgetto Giugiaro & Fabrizio: Italdesign*. Milano: Automobilia.
- MONTEMAGGI, Marco. (2008) 'Una lunga cavalcata: i tempi 'Eroici' dei motori in Italia'. Chapter in: MATERA, Eugenio and PIETROGRANDE, Patrizia. (eds.) *Il Mito della Velocità. Arte, motori e società nell'Italia del '900*. Florence: Giunti.
- NAHUM, Andrew. (2009) *Fifty cars that changed the world*. London: Conran Octopus.
- NEWBURY, Stephen. (2007) *The Car Design Yearbook 6*. London: Merrell Publishers.
- NEWBURY, Stephen and LEWIN, Toni. (2008) *The Car Design Yearbook 7*. London: Merrell Publishers.

- NIEUWENHUIS, Paul and WELLS, Peter (2009) 'Why Morgans are green'. Research Report of the Cardiff University. Available from: <http://www.morgan-motor.co.uk/green.html> [Accessed in January 2010].
- NOORDELOOS, Marc. (2007) 'Ferrari F40'. In: *Automobile Magazine Vol. 22, No.6*. September 2007. New York: Source Interlink Media.
- OICA, Organisation Internationale des Constructeurs d'Automobiles. (2008). *World Motor Vehicle Production - OICA 2008*. Available from: <http://oica.net/> [Accessed in January 2010].
- PAHL, G. and BEITZ, W. (1984) *Engineering design: a systematic approach*. London: Design Council.
- PAPANEK, Victor. (1984) *Design for the real world: human ecology and social change*. London: Thames and Hudson.
- PAPANEK, Victor. (1995) *The Green Imperative: Ecology & Ethics in Design and Architecture*. Londres: Thames and Hudson.
- PATTON, Phil. (2007) 'Smooth as the wind'. In: *Automobile Magazine Vol.22, No.3*. June 2007. New York: Source Interlink Media.
- PERFETTI, Giovanni. (2008) 'L'auto, interprete della velocità'. Chapter in: MATERA, Eugenio and PIETROGRANDE, Patrizia. (eds.) *Il Mito della Velocità. Arte, motori e società nell'Italia del '900*. Florence: Giunti.
- PININFARINA (2008) *Sintesi Magazine*. Geneva: Pininfarina.
- PININFARINA, Lorenza. (2008) 'Dream, fra poesia onirica e lucida di visione'. In: MOLINIERI, G and TUMMINELLI, P. (2008) *Dream l'auto del futuro dal 1950*. Torino: Umberto Allemandi.
- PININFARINA, Sergio. (2008) 'Il car designer dagli anni Trenta agli anni Cinquanta'. Chapter in: MATERA, Eugenio and PIETROGRANDE, Patrizia. (eds.) *Il Mito della Velocità. Arte, motori e società nell'Italia del '900*. Florence: Giunti.
- PORSCHE. (2009) *The Porsche way: the official history of the Dr. Ing. h.c. F. Porsche AG on DVD*. [DVD]. Stuttgart: Porsche-Museum.
- PRASAD, Deo K and SNOW, Mark (2004) *Designing with solar power: a source book for building integrated photovoltaics (BiPV)*. Woodbridge: Mulgrave.
- PUCHASKI, Kleber R. (2009) *Feel the future : perceptions of branding and design towards product development in the motor industry*. Thesis (PhD), Royal College of Art. London: CNPq and RCA.
- ROCHA, Ari Antonio da. (1973) *Veículo e a cidade*. Thesis (PhD), University of Sao Paulo. Sao Paulo: FAU USP.
- RODRIGUES, Osmar (2009). *Off-Road: the transportation of people over rough terrain*. Thesis (PhD), Royal College of Art. London: CNPq and RCA.

- ROSA, L.P. (2006) *Primeiro Inventario Brasileiro de Emissões Antropicas de Gases de Efeito Estufa. Emissões de dióxido de carbono e metano pelos reservatórios hidroelétricos brasileiro*. Research Report. Brasília: COPPE/MCT.
- ROTH, Daniel. (2008) 'Driven'. In: *Wired 16.09*. September 2008. San Francisco: Condé Nast.
- SAAB. (2008) *Saab Biopower*. Available from: <http://www.saabbiopower.co.uk/>. [Accessed in April 2008].
- SAINT LOUIS, V.C. (2000) 'Reservoir surface as source of greenhouse gases to the atmosphere : a global estimate'. In: *Bioscience 20*. Bordeaux: Université Bordeaux.
- SANCTIN, Thomas A. and STUDER, Margaret. (1994). 'A car, a watch? Swatchmobile!' In: *Time (website)*. Available from: <http://www.time.com/time/magazine/article/0,9171,980375,00.html>. [Accessed in January 2010].
- SCHWARZ, Stéphane (2010) Interview with Artur Grisanti Mausbach, London, February 2010.
- SEWELL, Brian. (1999). 'The language of form'. Chapter in: BAYLEY, S. and CHAPMAN, G. (eds), *Moving objects: 30 years of design at the Royal College of Art*. London: Eye-Q.
- SHARP, Robert (2008) 'Andando com duas fontes' . In: *Engenharia Automotiva e Aeroespacial. Ano 8. No.34*. Sao Paulo: Motor Press Brasil.
- SHERMAN, Don. (2007) 'Audi Quattro'. In: *Automobile Magazine Vol. 22, No.6*. September 2007. New York: Source Interlink Media.
- SHERMAN, Don. (2009) 'Toyota Prius, staying ahead of the hybrid pack'. In: *Automobile Magazine*. March 2009. New York: Source Interlink Media.
- SIDNEY, P. (1973) 'A Defense of Poetry' in DUNCAN-JONES and DORSTEN (eds.) *Miscellaneous Prose of Sir Philip Sidney*. Oxford: Oxford University Press.
- SIMPSON, J. (2009). 'Renault Twizy'. Available from: <http://cardesignnews.com> [Accessed in December 2009]
- SMART. (2007) *Smart*. Available: <http://www.smarttogo.co.uk/>. [Accessed in January 2007].
- SMART. (2010) *Smart*. Available: <http://uk.smart.com/> [Accessed in January 2010].
- SMITH, S. (2007) 'Volkswagen Rabbit GTI'. In: *Automobile Magazine Vol. 22, No.6*. September 2007. New York: Source Interlink Media.
- STERN, Nicholas. (2007) *The Stern Review*. Research Report. London: HM Treasury Cabinet Office.
- STEVENS, Peter. (1999) 'Cars are not Art' . Chapter Section in: BAYLEY, S. and CHAPMAN, G. (eds), *Moving objects: 30 years of design at the Royal College of Art*. London: Eye-Q.



- SUDJIC, Deyan.(2008) *The Language of Things*. London: Peguin Books.
- SZCZEPANEK, Adam.(2008) 'Electric Vehicle Infrastructure Development: an Enabler for the Electric Vehicle Adoption'. Conference Paper. MASMOUDI, A. *EVER International Conference on Ecological Vehicles and Renewable Energies*. March 2008. Monaco: EVER and Aero Vironment.
- TOYOTA (2006) *Toyota Website*. In: <http://www.toyota.co.uk>. [Accessed in January 2007]
- TOYOTA (2007) *Toyota Prius*. Booklet. Stamford: Toyota Automobile Company.
- TUMMINELLI, Paolo. (2004) *Car Design*. New York: TeNeues.
- TUMMINELLI, Paolo. (2008) 'Il Segreto dei sogni'. In: MOLINIERI, G and TUMMINELLI, P. (2008) *Dream l'auto del futuro dal 1950*. Torino: Umberto Allemandi.
- UNITED NATIONS FRAMEWORK CONVENTION ON CLIMATE CHANGE (UNFCCC) (2008) *Resource Guide*. Research Report. Bonn: UNFCCC.
- VENTURI. (2007) *Venturi Website*. Available from: <http://www.venturi.fr/>. [Accessed in March 2007].
- VENTURI. (2010) *Venturi Website*. Available from: <http://www.venturi.fr/>. [Accessed in March 2010].
- VENTURI COMMUNAUTE (2010) *History*. Available from: <http://www.venturi-owners.co.uk/public/history.html> [Accessed in January 2010]
- VEZZOLI, Carlo. (2000) *Design for sustainability: design guidelines ICS methods (simplified)* Sao Paulo: University of Sao Paulo.
- VIEIRA, José Luiz (2008) *A história do automóvel: a evolucao da mobilidade. Volume 1, da pré-história a1908*. Sao Paulo: Alaúde.
- VIEIRA, José Luiz (2009) *A história do automóvel: a evolucao da mobilidade. Volume 2, de 1908 a 1950*. Sao Paulo: Alaúde.
- WALKER, Stuart. (1997) 'Conscientious Objects - Product Aesthetics in the Context of Sustainability'. Chapter in: van HINTE, Ed. *Eternally Yours - Visions on Product Endurance*. Rotterdam: 010 Publishers.
- WALKER, Stuart. (2001) 'Games on a Stone Pavement: design, sustainability and meaning'. In: *Faculty of Environmental Design, University of Calgary website*: <http://www.ucalgary.edu>. [Accessed in March 2008]
- WALKER, Stuart. (2006) *Sustainable by Design: Explorations in theory and Practice*. London: Earthscan.
- WEERNINK, Win Oude. (2009) 'Gunak, rethinking the automobile'. In: *Auto & Design Magazine 176*. Torino: Auto & Design.

WEITMANN, Julius and STEINEMANN, Rico. (1978) *Project 928: a development history of the Porsche 928 from the first sketch to production*. Stuttgart: Motorbuch Verlag.

WHITELEGG, John. (1993) *Transport for a sustainable future: the case of Europe*. London: Belhaven Press.

*Who killed the electric car* (2006), Directed by Chris Paine, USA: Sony Pictures Classics. [Film: DVD].

WIKIPEDIA (2009) 'Prometheus'. In: *Wikipedia: the free encyclopaedia*. Available from: <http://en.wikipedia.org/wiki/Prometheus> [Accessed in July 2009]

WILLUMS, Jan Olaf. (2008) 'Major Global Trends in the Electrification of the Transport Sector: Where Does the Road Lead us?' Conference Paper. MASMOUDI, A. *EVER International Conference on Ecological Vehicles and Renewable Energies*. March 2008. Monaco: Think and EVER.

WILHEIM, Jorge. (2008) 'Planejamento urbano e mobilidade'. Conference Proceeding. In: SOCIETY OF AUTOMOTIVE ENGINEERS OF BRAZIL, *Challenges of urban mobility*. August 2008. Sao Paulo: SAE.

WOLF, Tom. (1966) *The kandy-kolored tangenrine-flake streamline baby*. London: Jonathan Cape.

WORLD COMMISSION ON ENVIRONMENT AND DEVELOPMENT (WCED). (1987) *Our Common Future*. New York: Oxford University Press.

## Appendix

Complementing the Car Design Timeline, shown at the beginning of this thesis, the appendix presents a table listing all the cars included in the Timeline. The table informs the main trend that each model represents, whilst a model sometimes also represents a secondary trend. The list is ordered chronologically, by age and year. In addition, the page numbers indicate where there is reference to each model in the text.

**Table 10: Index of cars included in the Car Design Timeline.**

	year	make	model	main trend	secondary trend	pages where it appears
Age of Pioneers	1886	Benz	Patent Motorwagen	Inventions		92, 94, 168
	1889		La Jamais Contente	Inventions		95
	1900	Lohner	Porsche Mixte	Inventions	Carriages	66
	1901	Mercedes-Benz	35 hp	Carriages	Inventions	95
	1911	Baker	Electric	Carriages	Inventions	68, 95
	1912	Rolls Royce	Silver Ghost	Limousines	Carriages	98, 242, 270
	1915	Ford	Model T	Carriages	Inventions	96, 103, 106, 242, 245
	1916	Alfa Romeo	40/60	Inventions	Streamlining	76
	1923	Rumpler	Tropfenwagen	Streamlining	Carriages	76
	1925	Bugatti	Type 35/	Cigars	(racing car icon)	99, 242
	1929	Dusemberg	Model J	Limousines	Pre-classic	98
	1929	Bugatti	Type 41 Royale	Limousines	Pre-classic	98
	1934	Citroen	Traction Avant	Pre-modern		103
	1934	Chrysler	Airflow	Streamlining	Pre-modern	101
	1935	Alfa Romeo	8C 2900	Pre-classic	Streamlining	102
	1936	Auto Union	C	Cigars	(racing car icon)	99
	1936	Cord	810	Pre-classic	Streamlining	102, 120
	1936	Mercedes-Benz	540 K	Pre-classic		
	1936	Fiat	500	Pre-modern		
	1937	Talbot	Lago F F	Streamlining	Pre-classic	102, 109
	1938	Bugatti	Type 57S Atlantic	Streamlining	Pre-classic	100
	1938	Cadillac	60	Pre-classic	Streamlining	
	1939	BMW	Millemiglia	Pre-modern	Streamlining	108, 116
	1939	Delahaye	165	Streamlining	Pre-classic	
	1940	Jeep	Willys	Utility	Pre-modern	105, 109
	1940	Lincoln	Continental	Streamlining	Pre-classic	101, 109
	1946	Volkswagen	1200	Pre-modern		104, 106, 191, 245

1947	Cisitalia	202	Flow Shell		108, 116, 128, 227
1948	Citroen	2CV	Utility	Pre-modern	106, 245
1948	Porsche	356	Flow Shell		110, 118
1948	Tucker	Torpedo	Flow Shell	Rocket	
1949	Jaguar	XK 120	Classic Line		116, 117
1949	Oldsmobile	88	Rocket		114
1950	Volkswagen	Microbus	Utility		
1950	Saab	92	Minicars		
1952	BMW	Isetta	Minicars		
1952	Bentley	Continental	Classic Line		116
1953	Messerschmitt	Kabinenroller	Minicars		
1953	Ford	F-100	Utility		
1953	Studebaker	Starliner	Flow Shell		109
1953	Chevrolet	Corvette	Rocket		
1954	Mercedes-Benz	300 SL	Flow Shell	Classic Body	
1957	Fiat	Nuova 500	Minicars	Soft Shell	112, 191
1957	Fiat	Multipla	Minicars	Soft Shell	112
1957	Citroen	DS	Flow Shell		110, 242, 270
1957	Chevrolet	Bel Air	Rocket		
1959	Mini	Cooper	Minicars	Soft Shell	112, 137, 191, 227
1959	Cadillac	Eldorado	Rocket		
1960	Chevrolet	Corvaire	New Line		
1961	Renalt	4 (F6)	Soft Shell	Utility	
1961	Jaguar	E-type	Classic Body		117
1962	Ferrari	250 GTO	Classic Body		
1962	Lotus	25	(racing car icon)	Classic Body	
1963	Alfa Romeo	GTA	Soft Shell	New Line	
1963	Jeep	Wagoneer	Utility	SUV	
1963	Buick	Riviera	New Line		120
1963	Chevrolet	Corvette Sting Ray	Classic Body	New Line	119
1964	Porsche	911	Classic Body		118, 124
1964	Ford	Mustang	New Line		119
1966	Ford	GT 40	(racing car icon)	Classic Body	
1966	Lamborghini	Miura	Classic Body		117
1966	Oldsmobile	Tornado	Edge Line		120
1967	Maserati	Ghilbi	Edge Line		
1968	Ferrari	Daytona	Edge Line		
1968	Astrodynamics	Deserter	(new typology)		
1968	Chevrolet	Corvette	Edge Line		
1969	Dino	246 GT	Classic Body		118, 123
1969	Datsun	240 Z	Edge Line	Flow Box	
1971	Land Rover	Range Rover	Utility	SUV	129
1971	Lamborghini	Countach	Wedge Line		122
1972	Honda	Civic	Edge Line	Edge Box	
1974	Volkswagen	Golf (Gti MK1)	Edge Box		125, 242
1974	Lancia	Stratus	Wedge Line		
1976	Lincoln	Mark IV	Edge Line		
1977	Lotus	Espirit	Wedge Line		123
1978	Porsche	928	Flow Box		124
1983	Fiat	Uno	Graphics	Edge Box	126
1983	Audi	Quattro	Sportiness	Edge Box	127
1984	Renault	Espace	MPV	Edge Box	

1984	Jeep	Cherokee	SUV	Edge Box	129
1986	BMW	M3	Graphics	Sportiness	126
1986	Porsche	959	Sportiness		128
1987	Ferrari	F40	Sportiness		129, 242
1987	Cadillac	Allante	Flow Box		
1988	Lancia	Delta HF Integrale	Graphics	Sportiness	127
1988	Mclaren	MP4/4	(racing car icon)	Sportiness	128
1989	Alfa Romeo	SZ	Flow Box		
1989	Ferrari	F1 640	(racing car icon)	Sportiness	128
1989	Mazda	Miata	Retro		133
1991	Opel	Calibra	Smooth Body		
1993	Renault	Twingo	Feminine	MPV	132
1993	Saturn	EV 1	Smooth Body		69, 136, 160
1994	Mclaren	F1	Sportiness	Carved Body	149, 151
1994	Opel	Tigra	Feminine	Smooth Body	
1994	Dodge	RAM	Grotesque		143
1996	Renault	Scenic	MPV	New Edge Box	132
1996	Lotus	Elise	Carved Body		
1996	Ford	Ka	New Edge Box	Feminine	136
1997	Porsche	Boxster	New Classic		
1997	Mercedes-Benz	A-Class	New Edge Box	MPV	137, 161, 184
1997	Alfa Romeo	156 Sportwagon	Individualism		141
1998	Smart	Fortwo	Minimalism	New Edge Box	47, 144, 176, 177, 184, 234, 242, (case study)
1998	Audi	A6	Geometrical	Smooth Body	136
1998	Dodge	RAM	Grotesque		
1998	Mercedes-Benz	M-Class	SUV		132
1998	Volkswagen	New Beetle	Retro		133
1999	Audi	A2	Minimalism	Smooth Body	78, 144
1999	Audi	TT	Geometrical	Smooth Body	135, 136
1999	Chrysler	PT Cruiser	Retro		134
1999	Honda	Insight	Smooth Body		226
2002	Mini	Cooper	Retro		134
2002	Porsche	Cayenne	SUV	Grotesque	132
2003	Aston Martin	Vantage V8	New Classic		140
2003	Bentley	Continental GT	New Classic		140
2003	BMW	5-Series	Carved Body		56, 138
2003	Fiat	Multipla	New Edge Box	Functionalism	
2003	Lamborghini	Gallardo	Edge Body		139
2003	Nissan	Cube	Minimalism		
2003	Rolls Royce	Phanton	New Classic		140
2004	Toyota	Prius	Minimalism		66, 78, 144, 216, 222, 234, 242, (case study)
2004	Mercedes-Benz	CLS	Individualism		142
2005	Hummer	H3	Grotesque		142
2005	Cadillac	STS	Edge Body		139
2005	Chrysler	300C	New Body	Edge Body	
2006	Bugatti	Veyron	New Classic		
2006	Ferrari	California	Carved Body		139
2007	FIAT	500	Retro		134

Age of Sustainability	2007	Venturi	Fetish	Conservative	Carved Body	70, 156, 192, 197, 234, 242, 259 (case study)
	2007	Tesla	Roadster	Conservative		70, 156, 259
	2009	Honda	Insight	Minimalism		78, 226
	2009	Toyota	iQ	Minimalism	Technomorphic	188, 220
	concept	BMW	Vision	Techonomorphic	Synthesist	151
	concept	Citroen	C-Cactus	Functionalism	Biomorphic	148
	concept	Daihatsu	UFE	Clean Shape	Biomorphic	
	concept	Fiat	Ecobasic	Functionalism	Technomorphic	147
	concept	Fioravanti	Thalia	Clean Shape		160
	concept	Fisker	Karma	Conservative		158
	concept	Giugiaro	Quaranta	Synthesist	Technomorphic	160
	concept	Giugiaro	Vad.ho	Cockpit Body	Technomorphic	154
	concept	GM	Jay Leno Ecojet	Conservative	Edge Body	158
	concept	GM	Autonomy	Cockpit Body		73, 153
	concept	Lexus	LF-XH	Functionalism		
	concept	Mazda	Taiki	Biomorphic		149, 260
	concept	Mercedes-Benz	F700	Biomorphic		148
	concept	Mercedes-Benz	Kofferfish	Biomorphic		148
	concept	Nissan	Pivo	Communicative	Active Body	163, 293
	concept	Pininfarina	Bollore	Clean Shape	Communicative	161, 162
	concept	Pininfarina	Sintesi	Synthesist		159, 161
	concept	Renault	Twizy	Communicative		162, 293
	concept	Toyota	Fine-T	Functionalism		148, 221
	concept	Toyota	Alessandro Volta	Conservative	Edge Body	155, 160, 219
	concept	Venturi	Astrolab	Techonomorphic	Cockpit Body	153, 192, 202, 293, (case study)
	concept	Venturi	Eclectic	Functionalism	Technomorphic	74, 147, 192, 207, (case study)
	concept	Volkswagen	L1	Clean Shape		
	project	Baruchin	Frisbee	Active Body		253, 285
	project	Deutchman	Core	Moving Spaces		276
	project	Eburah	Frisbee	Biomimetic		254, 286
	project	Harness	Fluid Sports	Body extension	Technomorphic	266
	project	Mausbach	Fluid Sports	Biomimetic		260, 264, 285
project	Philips	Core	Moving Spaces	Biomimetic	276, 284	
project	Westwater	Fluid Sports	Body extension	Biomorphic	265, 284	